

## PowerXL DA1 Series Drives



## Product Description

Eaton's PowerXL® DA1 variable frequency drives are the next generation of drives specifically engineered for today's machinery applications.

DA1 is the perfect match for demanding OEM applications. High-performance processor, safe torque off, multiple fieldbus protocols including SmartWire-DT, sensorless vector control and the possibility to operate permanent magnet motors are sure to leave a lasting impression.

Models rated at 480 volts, three-phase, 50/60 Hz are available in sizes ranging from 1 to 15 hp. Models rated at 240 volts, single- or three-phase, 50/60 Hz are available in sizes ranging from 0.5 to 7.5 hp. Models rated at 575 volts, three-phase, 50/60 Hz are available in sizes ranging from 1 to 20 hp.

## Features

- Compact, space-saving design
- Rugged and reliable—200% for 4s 50 °C rated
- DIN rail and screw mountable (FS1 and FS2)
- Side-by-side installation
- Industry-leading efficiency delivers energy savings to the customer
- Integrated EMC filters make the unit suitable for commercial and industrial networks
- Communication cards that integrate into the drive—
  - EtherNet/IP
  - DeviceNet
  - PROFIBUS-DP
  - EtherCAT
  - PROFINET
  - Modbus TCP
  - BACnet
- Brake chopper as standard
- Temperature-controlled fan
- RS-485/Modbus® and CANopen™ as standard
- PID controller as standard
- SmartWire capability
- Removable I/O terminal blocks
- Contactor style power wiring
- 200% torque at zero speed
- Designed to run surface mounted (SPM) and rotor in-built (IPM) permanent magnet motors
- PLC programming
- Closed loop
- Conformal coated boards

## Standards and Certifications

### Product

- Complies with EN61800-3 (2004)

### EMC (At Default Settings)

- EMC Category C1, C2 and C3 at default settings (1 m, 5 m, 25 m)

### Safety<sup>①</sup>

- 61800-5-1
- EN 60529
- CE
- UL
- cUL
- DNV
- UkrSepro
- c-Tick
- RoHS compliant



### Note

- ① See unit nameplate for more detailed approvals.

## Contents

### Description

	<i>Page</i>
PowerXL DA1 Series Drives	
Catalog Number Selection . . . . .	<b>V6-T2-26</b>
Product Selection . . . . .	<b>V6-T2-27</b>
Accessories . . . . .	<b>V6-T2-29</b>
Technical Data and Specifications . . . . .	<b>V6-T2-32</b>
Dimensions . . . . .	<b>V6-T2-34</b>

# 2.4

## Adjustable Frequency Drives

PowerXL DA1 Series Drives

### Catalog Number Selection

2

#### DA1 Series Adjustable Frequency AC Drives

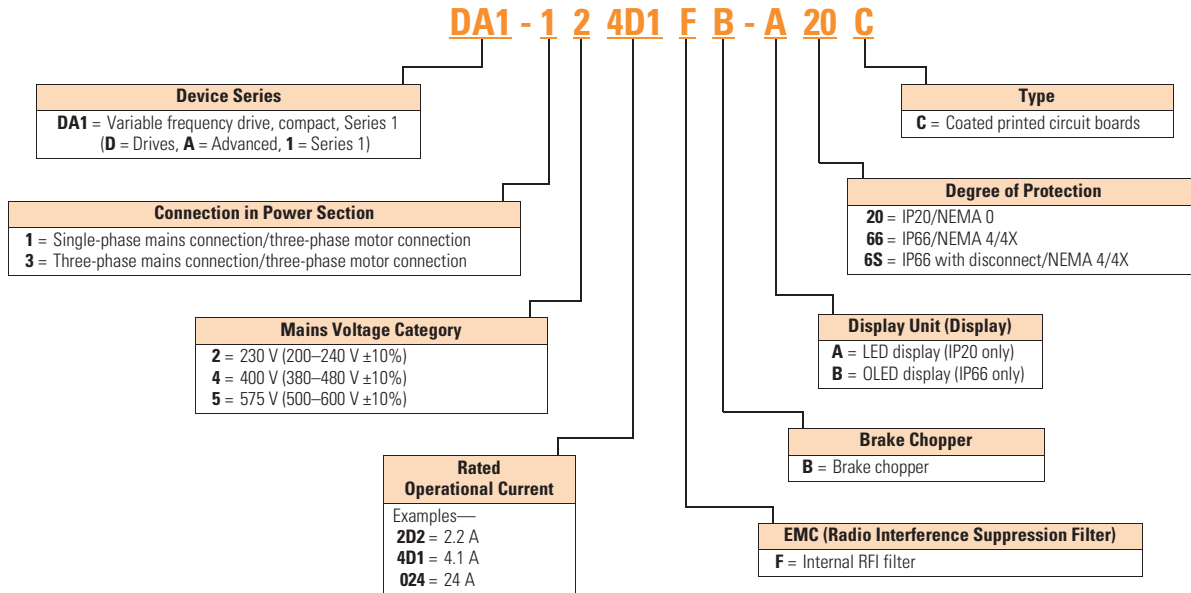

## Product Selection

IP20

DA1 Series IP20 Enclosure Drives <sup>①</sup>

hp <sup>②</sup>	kW	Volts	100% Continuous Current In (A)	Frame Size <sup>③</sup>	Catalog Number
1	0.75	200–240 V single-phase in/ 230 V three-phase out	4.3	2	DA1-124D3FB-A20C
2	1.5		7	2	DA1-127D0FB-A20C
3	2.2		10.5	2	DA1-12011FB-A20C
1	0.75	200–240 V three-phase in/ 230 V three-phase out	4.3	2	DA1-324D3FB-A20C
2	1.5		7	2	DA1-327D0FB-A20C
3	2.2		10.5	2	DA1-32011FB-A20C
5	4		18	3	DA1-32018FB-A20C
7.5	5.5		24	3	DA1-32024FB-A20C
1	0.75	380–480 V three-phase in/ 460 V three-phase out	2.2	2	DA1-342D2FB-A20C
2	1.5		4.1	2	DA1-344D1FB-A20C
3	2.2		5.8	2	DA1-345D8FB-A20C
5	4		9.5	2	DA1-349D5FB-A20C
7.5	5.5		14	3	DA1-34014FB-A20C
10	7.5		18	3	DA1-34018FB-A20C
15	11		24	3	DA1-34024FB-A20C
1	0.75	500–600 V three-phase in/ 575 V three-phase out	2.1	2	DA1-352D1NB-A20C
2	4.5		3.1	2	DA1-353D1NB-A20C
3	2.2		4.1	2	DA1-354D1NB-A20C
5	4		6.5	2	DA1-356D5NB-A20C
7.5	5.5		9	2	DA1-359D0NB-A20C
10	7.5		12	3	DA1-35012NB-A20C
15	11		17	3	DA1-35017NB-A20C
20	15		22	3	DA1-35022NB-A20C

**Notes**

- ① These are constant torque/high overload rated drives.
- ② For all applications, select the unit such that the motor current is less than or equal to the rated continuous output current.
- ③ Brake chopper circuit available as standard in frames 2 and 3.

# 2.4

## Adjustable Frequency Drives

### PowerXL DA1 Series Drives

2

#### IP66 NEMA 4/4X Interior DA1 Drive

The IP66 version of the DA1 is a unique solution to allow for mounting the drive outside of a control panel or next to a motor for distributed control.

#### “-B66C” Option

This version comes with the OLED keypad. There are no additional cover controls to address security concerns.

#### “-B6SC” Option

This version has an integrated potentiometer, a forward/off/reverse switch and a disconnect switch with lock-off capability with the OLED keypad. This allows for reduced labor and materials when compared to a IP20 solution in separate enclosure.

IP66



IP66S



#### DA1 Series IP66 Enclosure Drives <sup>①</sup>

IP66 NEMA 4/4X Interior DA1 Drive

hp <sup>②</sup>	kW	Volts	100% Continuous Current In (A)	Frame Size <sup>③</sup>	Catalog Number
1	0.75	200–240 V single-phase in/ 230 V three-phase out	4.3	2	<b>DA1-124D3FB-B6SC</b> <sup>④</sup>
2	1.5		7	2	<b>DA1-127D0FB-B6SC</b> <sup>④</sup>
3	2.2		10.5	2	<b>DA1-12011FB-B6SC</b> <sup>④</sup>
1	0.75	200–240 V three-phase in/ 230 V three-phase out	4.3	2	<b>DA1-324D3FB-B6SC</b> <sup>④</sup>
2	1.5		7	2	<b>DA1-327D0FB-B6SC</b> <sup>④</sup>
3	2.2		10.5	2	<b>DA1-32011FB-B6SC</b> <sup>④</sup>
5	4		18	3	<b>DA1-32018FB-B6SC</b> <sup>④</sup>
1	0.75	380–480 V three-phase in/ 460 V three-phase out	2.2	2	<b>DA1-342D2FB-B6SC</b> <sup>④</sup>
2	1.5		4.1	2	<b>DA1-344D1FB-B6SC</b> <sup>④</sup>
3	2.2		5.8	2	<b>DA1-345D8FB-B6SC</b> <sup>④</sup>
5	4		9.5	2	<b>DA1-349D5FB-B6SC</b> <sup>④</sup>
7.5	5.5		14	3	<b>DA1-34014FB-B6SC</b> <sup>④</sup>
10	7.5		18	3	<b>DA1-34018FB-B6SC</b> <sup>④</sup>
1	0.75	500–600 V three-phase in/ 575 V three-phase out	2.1	2	<b>DA1-352D1NB-B6SC</b>
2	4.5		3.1	2	<b>DA1-353D1NB-B6SC</b>
3	2.2		4.1	2	<b>DA1-354D1NB-B6SC</b>
5	4		6.5	2	<b>DA1-356D5NB-B6SC</b>
7.5	5.5		9	2	<b>DA1-359D0NB-B6SC</b>
10	7.5		12	3	<b>DA1-35012NB-B6SC</b>
15	11		17	3	<b>DA1-35017NB-B6SC</b>

#### Notes

- ① These are constant torque/high overload rated drives.
- ② For all applications, select the unit such that the motor current is less than or equal to the rated continuous output current.
- ③ Brake chopper circuit available as standard in frames 2 and 3.
- ④ Non-disconnect version available. Substitute with **-B66C**.

## Accessories

### DA1 Series

#### PC Communication Kit and Copy/Paste Module

Description	Catalog Number
Bluetooth copy/paste communication stick	<b>DX-COM-STICK2</b>
USB to RJ45 panel mount kit	<b>DX-COM-PCKIT</b>
USB to RJ45 PC Tool cable	<b>DX-CBL-PC-3M0</b>

#### Optional Communication Modules

Description	Catalog Number
DeviceNet plug-in interface module	<b>DX-NET-DEVICENET</b>
PROFIBUS-DP plug-in interface module	<b>DX-NET-PROFIBUS</b>
EtherNet/IP plug-in interface module	<b>DX-NET-ETHERNET-2</b>
EtherCAT plug-in interface module	<b>DX-NET-ETHERCAT-2</b>
PROFINET plug-in interface module	<b>DX-NET-PROFINET-2</b>
Modbus TCP plug-in interface module	<b>DX-NET-MOVBUSTCP-2</b>
BACnet/IP plug-in interface module	<b>DX-NET-BACNETIP-2</b>

#### Encoder Feedback Plug-In Option Module and Miscellaneous Cards

Description	Catalog Number
Expansion card: 3 relay outputs	<b>DXA-EXT-3RO</b>
Encoder feedback plug-in option module	<b>DXA-EXT-ENCOD</b>
Expansion card: 3 digital inputs and 1 relay output	<b>DXA-EXT-3DI1RO</b>

#### Remote Keypad

Description	Catalog Number
LED remote keypad—7-segment display, IP54 rated	<b>DX-KEY-LED2</b> <sup>①</sup>
OLED remote keypad—full text display, multi-line text, multi-language, IP54, hand/auto	<b>DX-KEY-OLED</b> <sup>①</sup>

#### Extension Cables and Data Cable Splitter

Description	Catalog Number
RJ45 communication cable w/terminating resistor	<b>EASY-NT-R</b>
RS-485 data cable, RJ45, 0.5 m	<b>DX-CBL-RJ45-0M5</b>
RS-485 data cable, RJ45, 1.0 m	<b>DX-CBL-RJ45-1M0</b>
RS-485 data cable, RJ45, 3.0 m	<b>DX-CBL-RJ45-3M0</b>
RS-485 three-way data cable splitter, RJ45	<b>DX-SPL-RJ45-3SL</b>
RS-485 data cable splitter, RJ45, (1 connector to 2 socket)	<b>DX-SPL-RJ45-2SL1PL</b>

#### SmartWire Modules

Description	Catalog Number
SmartWire-DT interface for DA1 IP20	<b>DX-NET-SWD1</b>

#### Note

<sup>①</sup> Includes 1 m RS-485 data cable.

# 2.4

## Adjustable Frequency Drives

### PowerXL DA1 Series Drives

2

#### Line and Load Reactors

A line and load reactor is a three-phase inductance filter that can be placed on the line and load side of the AFD to help improve the harmonic performance of the system. Consult the factory for additional filtering options and further technical details.

#### DR1 Line Reactor

A line reactor helps to provide a moderate reduction in current harmonics similar to a DC choke. It also provides increased input protection for AFD and its semiconductors from line transients helping to extend the life of the AFD.

#### DR2 Output Reactor

An output filter is used to reduce the transient voltage (dV/dt) at the motor terminals. The output filter is recommended for cable lengths exceeding 100 ft (30 m) with a drive of 3 hp and above and for cable lengths of 33 ft (10 m) with a drive of 2 hp and below.

#### Line and Load Reactors—Catalog Number Selection

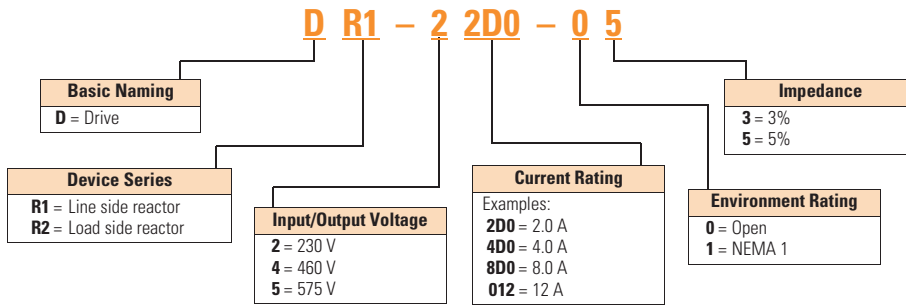

#### Line and Load Reactors—230 V

hp (CT)	Open Load Reactor		Line Reactor		NEMA 1 Load Reactor		Line Reactor	
	3%	5%	3%	5%	3%	5%	3%	5%
1	DR2-24D0-03	DR2-28D0-05	DR1-24D2-03	DR1-24D2-05	DR2-24D0-13	DR2-28D0-15	DR1-24D2-13	DR1-24D2-15
2	DR2-28D0-03	DR2-28D0-05	DR1-26D8-03	DR1-26D8-05	DR2-28D0-13	DR2-28D0-15	DR1-26D8-13	DR1-26D8-15
3	DR2-2012-03	DR2-2012-05	DR1-29D6-03	DR1-29D6-05	DR2-2012-13	DR2-2012-15	DR1-29D6-13	DR1-29D6-15
5	DR2-2018-03	DR2-2018-05	DR1-2015-03	DR1-2015-05	DR2-2018-13	DR2-2018-15	DR1-2015-13	DR1-2015-15
7.5	DR2-2025-03	DR2-2025-05	DR1-2022-03	DR1-2022-05	DR2-2025-13	DR2-2025-15	DR1-2022-13	DR1-2022-15

## Line and Load Reactors—480 V

hp (CT)	Open Load Reactor	
	3%	5%
	1	DR2-42D0-03
2	DR2-44D0-03	DR2-44D0-05
3	DR2-48D0-03	DR2-48D0-05
5	DR2-48D0-03	DR2-48D0-05
7.5	DR2-4012-03	DR2-4012-05
10	DR2-4018-03	DR2-4018-05
15	DR2-4025-03	DR2-4025-05

Line Reactor	
3%	5%
DR1-42D1-03	DR1-42D1-05
DR1-43D4-03	DR1-43D4-05
DR1-44D8-03	DR1-44D8-05
DR1-47D6-03	DR1-47D6-05
DR1-4011-03	DR1-4011-05
DR1-4014-03	DR1-4014-05
DR1-4021-03	DR1-4021-05

NEMA 1 Load Reactor	
3%	5%
DR2-42D0-13	DR2-42D0-15
DR2-44D0-13	DR2-44D0-15
DR2-48D0-13	DR2-48D0-15
DR2-48D0-13	DR2-48D0-15
DR2-4012-13	DR2-4012-15
DR2-4018-13	DR2-4018-15
DR2-4025-13	DR2-4025-15

Line Reactor	
3%	5%
DR1-42D1-13	DR1-42D1-15
DR1-43D4-13	DR1-43D4-15
DR1-44D8-13	DR1-44D8-15
DR1-47D6-13	DR1-47D6-15
DR1-4011-13	DR1-4011-15
DR1-4014-13	DR1-4014-15
DR1-4021-13	DR1-4021-15

## Line and Load Reactors—575 V

hp (CT)	Open Load Reactor	
	3%	5%
	1	DR2-52D0-03
2	DR2-54D0-03	DR2-54D0-05
3	DR2-54D0-03	DR2-54D0-05
5	DR2-58D0-03	DR2-58D0-05
7.5	DR2-58D0-03	DR2-58D0-05
10	DR2-5012-03	DR2-5012-05
15	DR2-5018-03	DR2-5018-05
20	DR2-5025-03	DR2-5025-05

Line Reactor	
3%	5%
DR1-51D7-03	DR1-51D7-05
DR1-52D7-03	DR1-52D7-05
DR1-53D9-03	DR1-53D9-05
DR1-56D1-03	DR1-56D1-05
DR1-59D0-03	DR1-59D0-05
DR1-5011-03	DR1-5011-05
DR1-5017-03	DR1-5017-05
DR1-5022-03	DR1-5022-05

NEMA 1 Load Reactor	
3%	5%
DR2-52D0-13	DR2-52D0-15
DR2-54D0-13	DR2-54D0-15
DR2-54D0-13	DR2-54D0-15
DR2-58D0-13	DR2-58D0-15
DR2-58D0-13	DR2-58D0-15
DR2-5012-13	DR2-5012-15
DR2-5018-13	DR2-5018-15
DR2-5025-13	DR2-5025-15

Line Reactor	
3%	5%
DR1-51D7-13	DR1-51D7-15
DR1-52D7-13	DR1-52D7-15
DR1-53D9-13	DR1-53D9-15
DR1-56D1-13	DR1-56D1-15
DR1-59D0-13	DR1-59D0-15
DR1-5011-13	DR1-5011-15
DR1-5017-13	DR1-5017-15
DR1-5022-13	DR1-5022-15

## Technical Data and Specifications

### DA1 Series

2

#### Ratings

##### PowerXL DA1 Basic Controller IP20 Standard Ratings

Description	Specification
<b>Protections</b>	
Overload protection	150% for 60s for every 600 seconds
Overvoltage protection	Yes
Undervoltage protection	Yes
Ground fault protection	Yes
Overtemperature protection	Yes
Motor overload protection	Yes
Motor stall protection	Yes
Short-circuit withstand rating	100 kAIC with Type J fuses

#### Programmable Parameters

Description
Built-in Help card
14 Standard operation parameters
Reference scaling
Programmable start and stop functions
DC-brake at start and stop
Programmable V/Hz curve
Adjustable switching frequency
Autorestart function after fault
Protections and supervisions
Power section fault indication
External fault
Fieldbus communication
Safe torque off (STO) function
Analog input range selection, signal scaling and filtering
PI controller
Skip frequencies

#### Specifications

##### PowerXL DA1 Series Drives

Description	Specification
<b>Input Ratings</b>	
Input voltage ( $V_{in}$ )	$\pm 10\%$
Input frequency ( $f_{in}$ )	50/60 Hz (variation up to 48–62 Hz)
Connection to power	Maximum of one time every 30 seconds
<b>Output Ratings</b>	
Output voltage	0 to $V_{in}$ ①
Continuous output current	Continuous rated current $I_N$ at ambient temperature max. 122 °F (50 °C), 150% for 60 seconds, 200% for 4 seconds
Output frequency	0 to 500 Hz
Frequency resolution	0.1 Hz
Initial output current ( $I_{H}$ )	200% for 4s for every 40 seconds Torque depends on motor
<b>Control Characteristics</b>	
Operation mode	U/f control, slip compensation, sensorless vector control (SLV), vector control with feedback (CLV)
Switching frequency	4 to 32 kHz
Voltage reference	10 Vdc (max. 10 mA)
Field weakening point	0 to 500 Hz
Acceleration time	0.1 to 600 seconds
Deceleration time	0.1 to 600 seconds
<b>Brake Resistor (Minimum Values) ②</b>	
230 V Series	FS2 and FS3 15 ohms
400 V Series	FS2 33 ohms, FS3 22 ohms
<b>Ambient Conditions</b>	
Ambient operating temperature	+14 °F (–10 °C), no frost to +122 °F (+50 °C): Rated loadability $I_N$ IP20—NEMA 0
Storage temperature	–40 °F (–40 °C) to +140 °F (+60 °C)
Relative humidity	0 to 95% RH, noncondensing, non-corrosive, no dripping water
Enclosure class	IP20 (FS2 and FS3)

#### Notes

- ① Exception: 115 V single-phase in, 230 V three-phase out.  
 ② Only FS2 and FS3 drives are equipped with brake chopper circuit.



## Standards—DA1 Series

## I/O Specifications

- Digital inputs D11–D15 are programmable
- Digital, relay and analog outputs are programmable

Includes:

- Five inputs (three digital and two digital/analog)
- Analog inputs
  - 4–20 mA
  - 0–10 V
- Two outputs (analog or digital)
- Two relay outputs
- RS-485 interface

## Reliability

- Pretested components
- Computerized testing
- Final test with full load
- Conformal-coated boards
- Eaton's Electrical Services & Systems: national network of AF drive specialists

## DA1 Series I/O Interface

Terminal	Signal	Factory Preset	Description
1	+24 Vdc	Control voltage for D11–D15	Maximum load 100 mA Reference potential V
2	D11	Digital Input 1	Start Enable FWD ①
3	D12	Digital Input 2	Start Enable REV ①
4	D13	Digital Input 3	Fixed frequency FF1/FF2 ①
5	+10 Vdc	Reference voltage, Output (+10 V)	Maximum load 10 mA Reference potential 0 V
6	A11	Analog Input 1	Frequency reference value ①
	D14	Digital Input 5	Frequency reference value ①
7	0 V	Reference potential	0 V = connection terminal 9
8	A01	Analog Output 1	Output frequency
	D01	Digital Output 1	Output frequency
9	0 V	Reference potential	0 V connection terminal 7
10	D14	Digital Input 4	Fixed frequency FF2 ①
	A12	Analog Input 2	Fixed frequency FF2 ①
11	A02	Analog output 2	Output current ①
	D02	Digital output 2	Output current ①
12	STO+	Safe Torque Off +	Enable = +24 V
13	STO-	Safe Torque Off -	Enable = 0 V
14	K11	Relay 1, changeover contact	Active = FAULT ①
15	K14	Relay 1, changeover contact (N/O)	Active = FAULT ①
16	K12	Relay 1, changeover contact (N/C)	Active = FAULT ①
17	K23	Relay 2, N/O contact	Active = FAULT ①
18	K24	Relay 2, N/C contact	Active = FAULT ①

## Note

① Programmable function.

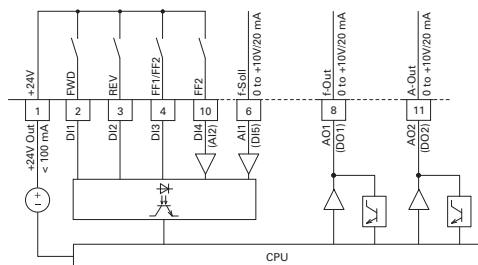

# 2.4

## Adjustable Frequency Drives

### PowerXL DA1 Series Drives

#### Dimensions

Approximate Dimensions in Inches (mm)

#### 2 DA1, Sizes FS2 and FS3, Degree of Protection IP20/NEMA 0

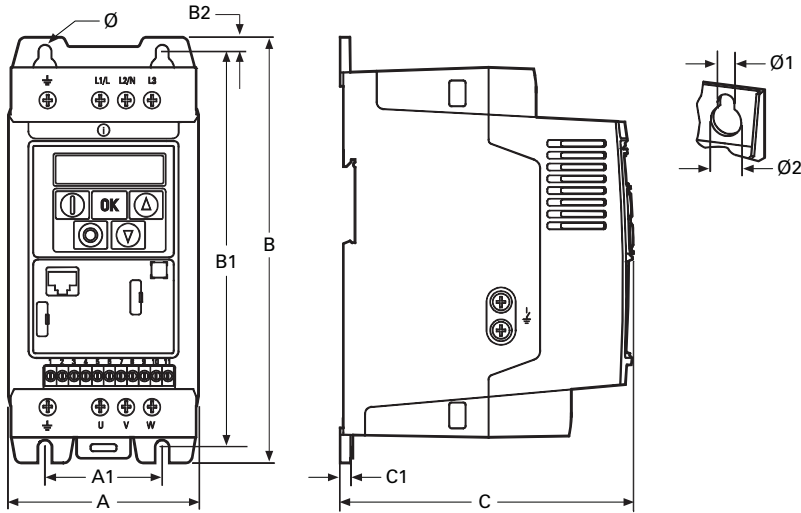

Frame Size	A	A1	B	B1	B2	C	C1	Ø1	Ø2	Weight lbs (kg)
FS2	4.21 (107.0)	2.95 (75.0)	9.09 (231.0)	8.46 (215.0)	0.31 (8.0)	7.32 (186.0)	0.20 (5.0)	0.24 (6.0)	0.47 (12.0)	3.97 (1.8)
FS3	5.16 (131.0)	3.94 (100.0)	10.75 (273.0)	10.04 (255.0)	0.33 (8.5)	8.03 (204.0)	0.20 (5.0)	0.24 (6.0)	0.47 (12.0)	7.72 (3.5)

#### DA1, Sizes FS2 and FS3, Degree of Protection IP66/NEMA 4

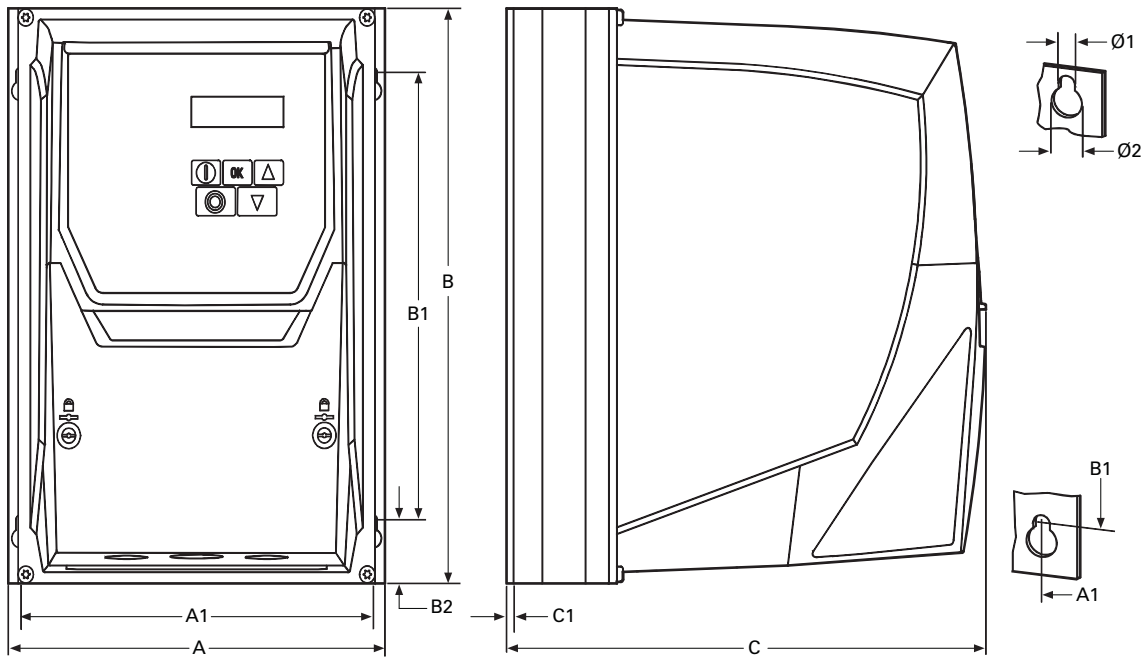

Frame Size	A	A1	B	B1	B2	C	C1	Ø1	Ø2	Weight lbs (kg)
FS2	7.40 (188.0)	6.93 (176.0)	10.12 (257.0)	7.87 (200.0)	0.79 (20.0)	9.42 (239.3)	0.14 (3.5)	0.16 (4.2)	0.33 (8.5)	10.4 (4.5)
FS3	8.29 (211.0)	7.78 (198.0)	12.20 (310.0)	9.90 (252.0)	0.98 (25.0)	10.48 (266.3)	0.14 (3.5)	0.16 (4.2)	0.33 (8.5)	15.9 (7.0)

Approximate Dimensions in Inches (mm)

## DA1, Sizes FS2 and FS3, Degree of Protection IP66/NEMA 4, with Local Controls

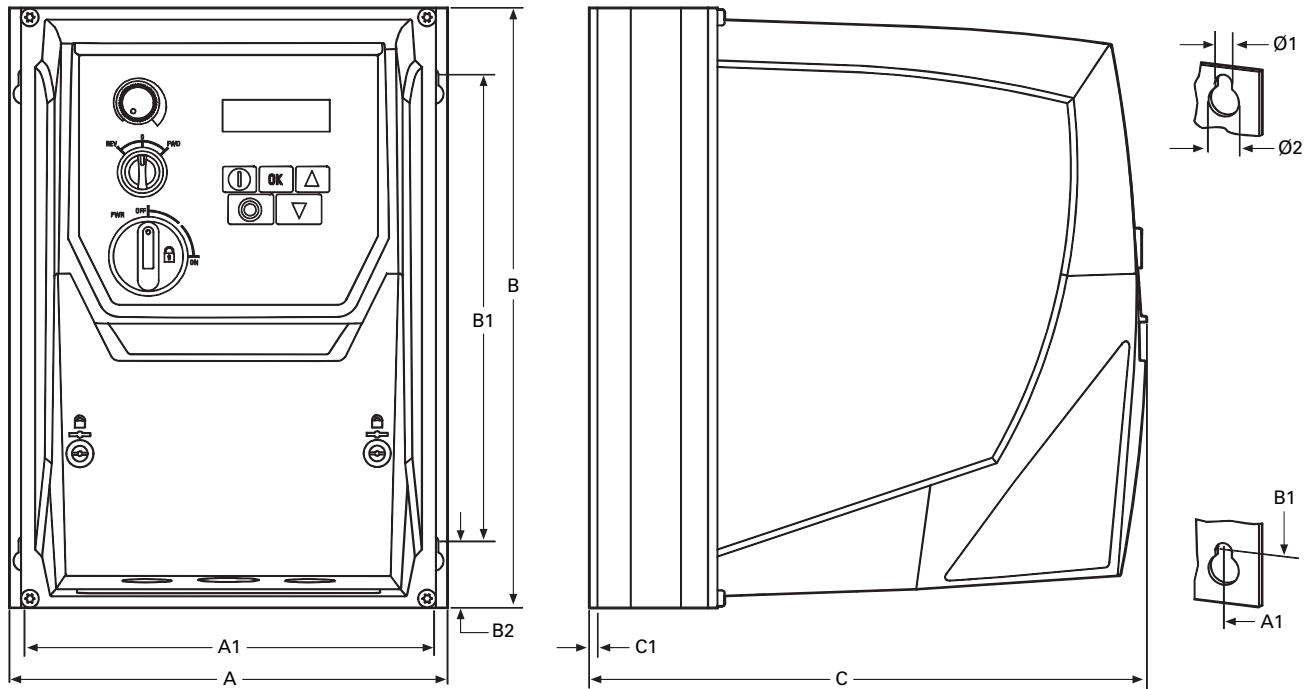

Frame Size	A	A1	B	B1	B2	C	C1	Ø1	Ø2	Weight lbs (kg)
FS2	7.40 (188.0)	6.93 (176.0)	10.12 (257.0)	7.87 (200.0)	0.79 (20.0)	9.42 (239.3)	0.14 (3.5)	0.16 (4.2)	0.33 (8.5)	10.6 (4.8)
FS3	8.29 (211.0)	7.78 (198.0)	12.20 (310.0)	9.90 (252.0)	0.98 (25.0)	10.48 (266.3)	0.14 (3.5)	0.16 (4.2)	0.33 (8.5)	16.1 (7.3)