

Premium Ultra-Slim Pneumatic Desktop Sit-Stand Workstation

pro-SIGNAL



Description

50-25010 is the next evolutionary step in sit-stand desktop workstations. So thin and sleek it virtually melts into the desk its sitting on. With a contemporary minimalist design and simple operation, it comes out of the box ready to use without any assembly. The desktop uses high grade, composite MDF board that is stable, impact-resistant. The Steel frame provides a solid and long-lasting performance and the simple lift and lower mechanism is smooth to quickly adjust to your desired height. Best of all, the 50-25010 helps you become more active and healthy while improving your productivity.

Features

- Step less height settings for your free height adjustment
- Non-skid rubber pads protect work surface from scratches or scuffs
- Ultra-Slim profile for space saving & easy storage
- Quality MDF board features high impact resistance
- Steel construction provides a solid, and long-lasting performance

Specifications

Type	: Tabletop Workstation, Standard
Material	: Plastic, MDF & PVC, Steel, Aluminium
Colour	: Brown Desktop with Black Base, Black, White
Dimensions	: 797mm × 560mm × 48mm ~ 410mm (31.4" × 22" × 1.9" ~ 16.1")
Work Surface Size (L × W)	: 797mm × 560mm (31.4" × 22")
Tabletop Thickness	: 15mm (0.59")
Height Range	: 48mm ~ 410mm (1.9" ~ 16.1")
Height Adjustment	: Manual
Work Surface Weight Capacity	: 10kg (22lbs)
Keyboard Weight Capacity	: 2kg (4.4lbs)
Installation	: Tabletop Stand

Diagram



Premium Ultra-Slim Pneumatic Desktop Sit-Stand Workstation

pro-SIGNAL

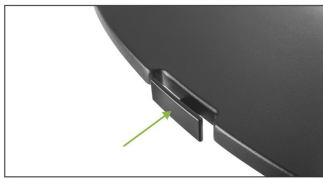

Quick-Release Side Lock
Allows effortless and efficient height adjustment

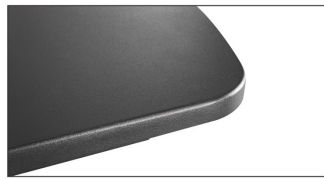

Quality MDF Board
Features high impact resistance



Non-Skid Silicone Pads
Protect work surface from scratches or scuffs

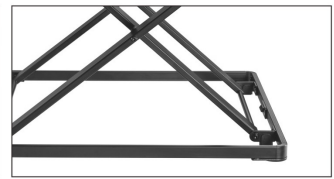

Steel Construction
Provides a solid, and long-lasting performance



Weight Capacity
10kg/22lbs



Desktop Thickness
15mm

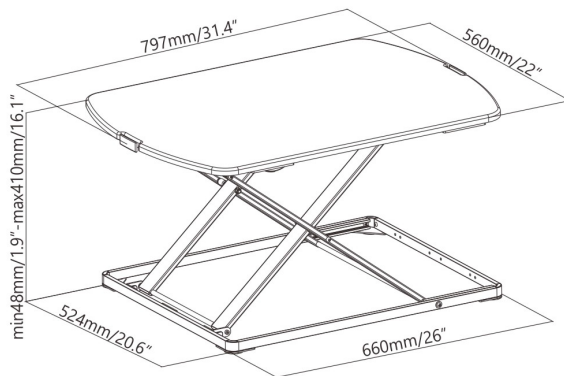

Dimensions : Millimetres (Inches)

Part Number Table

Description	Part Number
Premium Ultra-Slim Pneumatic Desktop Sit-Stand Workstation	50-25010

Important Notice : This data sheet and its contents (the "Information") belong to the members of the Premier Farnell group of companies (the "Group") or are licensed to it. No licence is granted for the use of it other than for information purposes in connection with the products to which it relates. No licence of any intellectual property rights is granted. The Information is subject to change without notice and replaces all data sheets previously supplied. The Information supplied is believed to be accurate but the Group assumes no responsibility for its accuracy or completeness, any error in or omission from it or for any use made of it. Users of this data sheet should check for themselves the Information and the suitability of the products for their purpose and not make any assumptions based on information included or omitted. Liability for loss or damage resulting from any reliance on the Information or use of it (including liability resulting from negligence or where the Group was aware of the possibility of such loss or damage arising) is excluded. This will not operate to limit or restrict the Group's liability for death or personal injury resulting from its negligence. pro-SIGNAL is the registered trademark of the Group. © Premier Farnell Limited 2016.

www.element14.com
www.farnell.com
www.newark.com
www.cpc.co.uk

pro-SIGNAL