

# Simplify Your Industrial Interface by Eliminating RS-485 Control Lines

## Introduction

The RS-485 network interface is often the interface of choice for industrial applications because of its robust differential performance over long cable runs. The half-duplex RS-485 implementation appears as the physical layer in utility, factory automation, HVAC, and many more industrial equipment systems. Half-duplex RS-485 networks offer minimal distributed wiring, resulting in remote stations that share a single pair of copper wires as the communications medium (Figure 1).

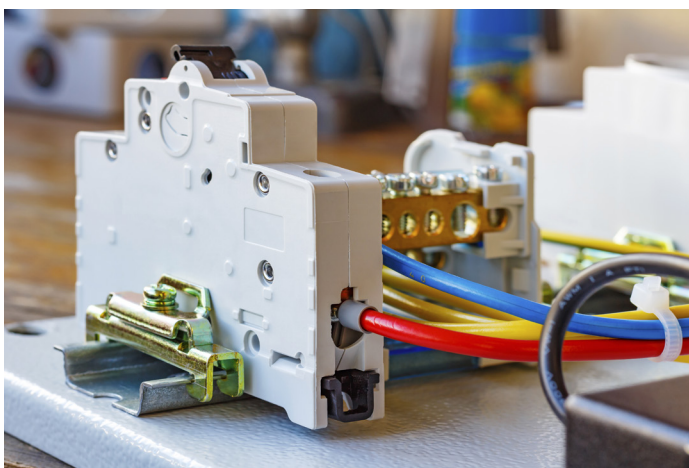

Figure 1. DIN Connector

One of the challenges for networks that have multiple RS-485 transceivers is to manage the local receive and transmit enable pins. For true multi-channel, bidirectional transmission, these pins provide a means for system designers to determine when the RS-485 is transmitting or receiving. Depending on the application, these two enable pins can be connected to each other through PCB traces to a local processor or controller. With this type of connection, there are three lines to isolate; the driver and receiver enable (DE/ $\overline{RE}$ ), the driver input (DI), and the receiver output (RO) lines.

This article outlines traditional half-duplex RS-485 configurations and then presents new alternatives for simplifying the control interface by eliminating the required control lines and software control code.

## Traditional Half-Duplex RS-485 Configurations

RS-485 (TIA/EIA-485) is a wired communication standard that uses differential signals to allow data transmissions over long distances. In noisy industrial and factory automation environments, the RS-485 differential signals make it more robust and withstand common-mode noise. The twisted-pair signal cable ensures that received interference is mostly common mode.

Bidirectional channels use half-duplex devices for communication over a pair of twisted cable. For the RS-485 device, the Rx and Tx terminals connect to the A (noninverting) and B (inverting) IC package pins. The receiver's output (RO) and the driver's input (DI) terminals connect to separate pins (Figure 2).

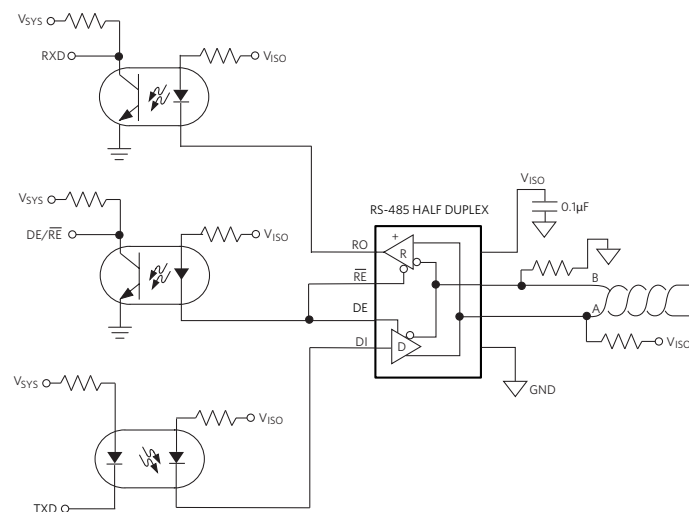

Figure 2. An isolated half-duplex RS-485 channel contains three or four optocouplers to accomplish full signal transceiver activity.

In certain applications, isolation from optocouplers or other isolators are required. The optocoupler channels in Figure 2 clearly illustrate the number of required lines for the RS-485 transceiver. Note the connection of the  $\overline{RE}$  and DE pins. In most applications, this connection is appropriate. In other applications, the  $\overline{RE}$  and DE pins are separate. The system processor or controller drives the  $\overline{RE}$  and DE control pins in response to the length of time that a node must stay enabled for transmitted packets of data, which vary from application to application.

### Removing Control Lines in an RS-485 Network

The MAX13487E successfully eliminates the manipulation of the RS-485 transceiver's  $\overline{RE}$  and DE control lines by using an on-chip AutoDirection state machine (Figure 3).

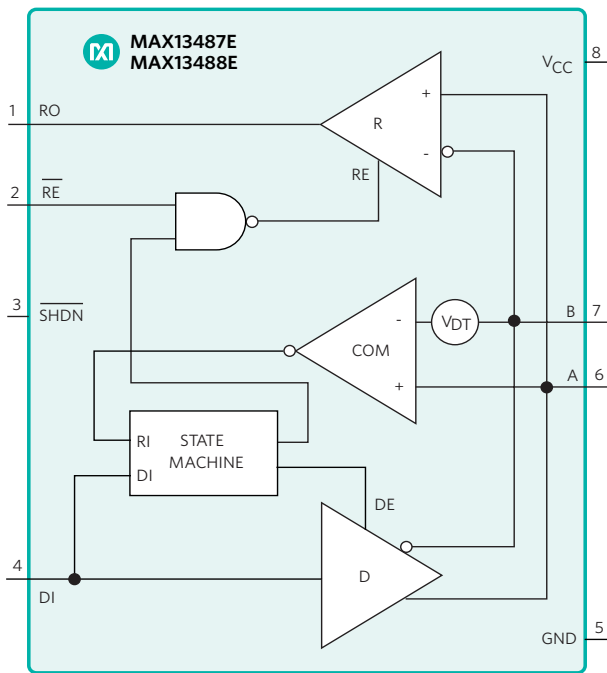

Figure 3. Functional diagram of the MAX13487E (a reduced slew-rate driver) and the MAX13488E (an unlimited slew-rate driver)

In Figure 3, the proper AutoDirection state machine configuration is to connect the  $\overline{RE}$  and SHDN pins high and for proper operation use an external pullup resistor on A and a pulldown resistor on B.

Although signal isolation is not a requirement, the optocoupler channels in Figure 4 clearly illustrate the number of required lines for the RS-485 transceiver.

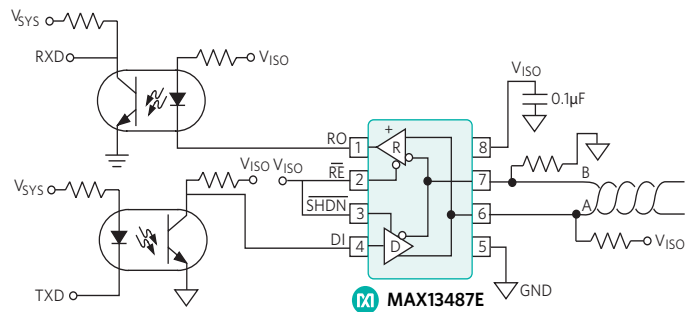

Figure 4. A half-duplex MAX13487E, RS-485 transceiver with an internal AutoDirection state machine reduces the isolation channel count from three or four to two

In Figure 4, the MAX13487E's active digital channels are the DI (transmit) and RO (receive) pins. The AutoDirection state machine determines whether the device or another node on the network is driving the bus. Depending on the activity on the bus, the AutoDirection state machine automatically disables or enables the MAX13487E driver and receiver.

A conventional RS-485 transceiver uses DE and  $\overline{RE}$  inputs for driver and receiver enable/disable states. In contrast, the MAX13487E/MAX13488E internal state machine, which enables and disables the driver, substitutes for the absence of the DE input. For proper operation, the non-transmitting MAX13487E/MAX13488E requires a high DI input, keeping the device in its idle state.

In this manner, the MAX13487E AutoDirection state machine successfully facilitates the transmission and reception of active signals on the RS-485 bus as well as changes to a high-impedance mode by monitoring the RS-485's driver and bus activity.

The MAX13487E/MAX13488E are half-duplex RS-485/RS-422-compatible transceivers with AutoDirection control. The MAX13487E, which is appropriate for this optocoupler application, has reduced slew-rate drivers that minimize EMI and reduce reflections caused by improperly terminated cables, allowing error-free transmission up to 500kbps. There are no slew-rate limits for the MAX13488E, enabling transmit speeds up to 16Mbps.

### Conclusion:

The MAX13487E/MAX13488E RS-485 transceivers provide a half-duplex interface solution. The MAX13487E/MAX13488E on-chip AutoDirection state machine effortlessly manages the RS-485 half-duplex receiver and transmission tasks while

using only one control line. This design solution explained how the MAX13487E reduces slew-rate drive to minimize EMI and reduce reflections. The AutoDirection circuitry tackles this interface problem while also simplifying the circuit by eliminating the need for the dedicated microcontroller/processor control pins and the PCB lines.

## Glossary

**RS-485:** A long-distance, multiple-device communications bus that has a shielded twisted pair (STP), differential interface.

**Half-Duplex:** A communications system that allows the transmission of signals in both directions but not simultaneously.

## Learn more:

[MAX13487E Half-Duplex RS-485-/RS-422-Compatible Transceivers with AutoDirection Control](#)

[MAX13488E Half-Duplex RS-485-/RS-422-Compatible Transceivers with AutoDirection Control](#)

[MAX13410E RS-485 Transceivers with Integrated Low-Dropout Regulator and AutoDirection Control](#)

[MAX13411E RS-485 Transceivers with Integrated Low-Dropout Regulator and AutoDirection Control](#)

[MAX13412E RS-485 Transceivers with Integrated Low-Dropout Regulator and AutoDirection Control](#)

[MAX13413E RS-485 Transceivers with Integrated Low-Dropout Regulator and AutoDirection Control](#)

Design Solutions No. 96

Rev 0; March 2018

[Visit the Maxim Support Center](#)

[Find More Design Solutions](#)

Maxim Integrated  
160 Rio Robles  
San Jose, CA 95134 USA  
408-601-1000

[maximintegrated.com/design-solutions](http://maximintegrated.com/design-solutions)

