

## Avoid Catastrophic Power Failures with Proper Voltage Sequencing and Monitoring

### Introduction

Every application needs power, but power design is often an afterthought. Engineers may choose a power solution simply to meet their load and price point demands. Designing a power solution with more information up front results in a better power system choice that improves the end-product and reduces costly rework.

Overlooking supply sequencing and monitoring may be a disastrous misstep, as this is a critical part of the health and well-being of systems such as telecom equipment, storage systems, servers, or networking systems. As an example, a workstation system can have different power-supply rails for analog circuitry, microprocessors, DSPs, ASICs, and FPGAs. This system requires supply sequencing and monitoring for both power-up and power-down scenarios. If not, a profound power-supply overvoltage can produce catastrophic failures (Figure 1).

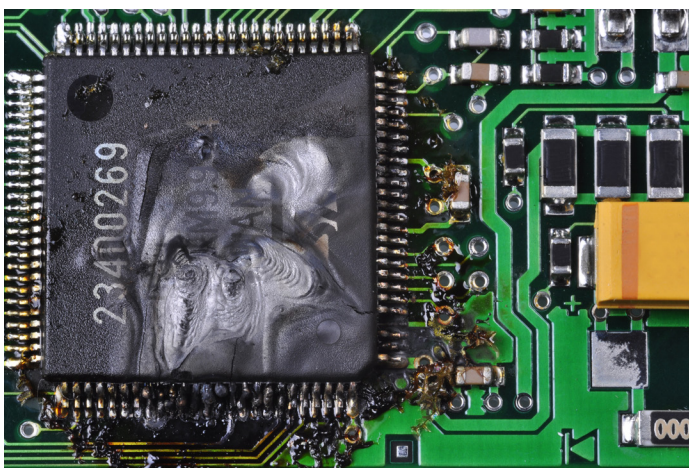

Figure 1. Overheated Damaged Processor Chip Due to Improper Power-Supply Sequencing

This article considers a typical power control system, which sequentially initiates the power-up of multiple power supplies to protect the system microcontroller. It then outlines a simple alternative solution which, in addition to power-up sequencing, provides additional functions without added software to

significantly decrease the likelihood of a catastrophic system failure.

### Power-Supply Sequencing Systems

The safety and proper operation of a microprocessor depend on proper power-supply voltage rail sequencing. Power-supply sequencing is a method for turning on supplies in a specific order. The control of the supply sequencing is based on the system requirements, where a single supply or several depend on another supply to reach a threshold voltage.

Simple R/C time constants conveniently start a multiple supply system. Separate R/C time constants institute delays for each power supply. This basic sequencing power control combines a series FET transistor and several resistor-capacitor pairs (Figure 2).

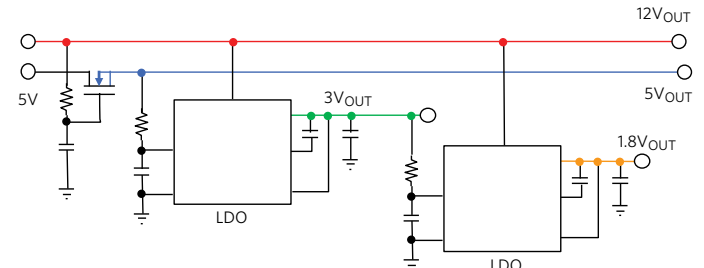

Figure 2. Discretely Sequencing Four Power Supplies with External Resistor-Capacitor Delays

In Figure 2, the four available output voltages are 12V, 5V, 3V, and 1.8V. In terms of power-supply sequencing, the 12V supply is immediately available at system power-up (Figure 3).

The 5V supply soon follows with a resistor-capacitor rise time connected to a series FET. As the 5V supply becomes available, the resistor-capacitor pair (connected to the 3V LDO's enable pin) starts to charge. With the appearance of the LDO's 3V output, the resistor-capacitor pair (connected to the 1.8V LDO enable pin) starts to charge. Finally, all four supplies are available. The power-supply startup delays ( $t_1$ ,  $t_2$ , and  $t_3$ ) depend on the rise time of the attached resistor-capacitor pairs.

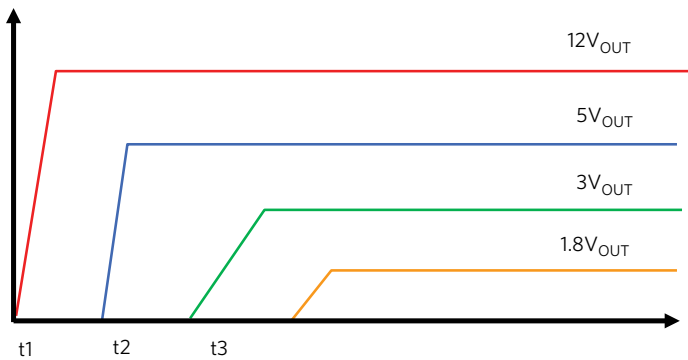

Figure 3. Power-Up Sequence of Supplies in Figure 2

This discrete power-supply sequencing circuit is effective for small systems. If the selection of the R/C values are incorrect or the rise time of the 3V LDO is too slow, there is a possibility that there will be a downstream error. Additionally, there is no capability for monitoring the health of the power-supply voltages or bringing them down in any particular order.

### Fully Automated Power Sequencing

An alternative system for the power management system is to use an integrated circuit that sequences power-up, monitors the powered voltages, and sequences power-down activities (Figure 4).

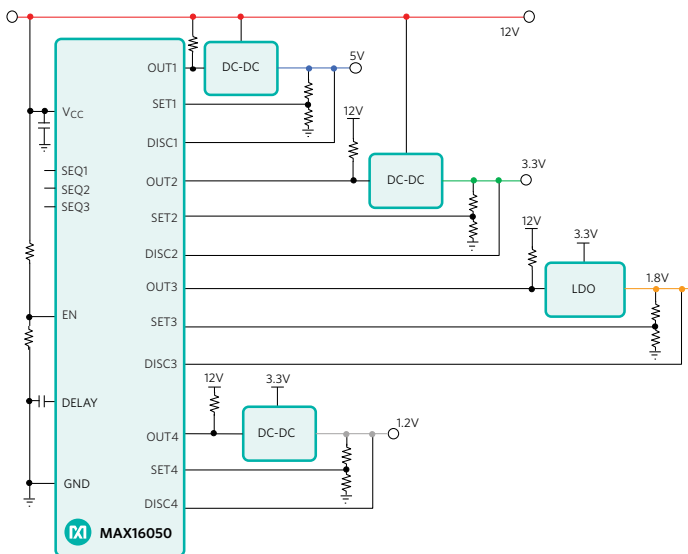

Figure 4. The MAX16050 Easily Sequences, Monitors and Sequentially Powers Down Multiple Power Supplies

With the MAX16050 voltage monitor/sequencer, the logic states of sequence pins (SEQ1, SEQ2, and SEQ3) determine the startup order of the open-drain outputs (OUT1, OUT2, OUT3, and OUT4). When all three sequence pins are in a high-impedance state, the startup order is OUT1 → OUT2 → OUT3 → OUT4.

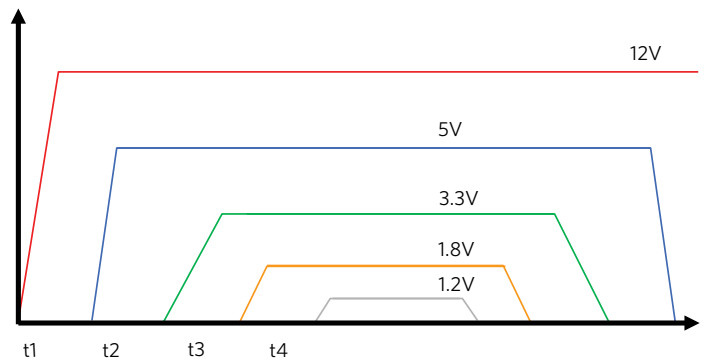

Figure 5. The MAX16050 Controls the On and Off Power Sequencing

The MAX16050 constantly monitors all output voltage values. The sequence delay between each output is dependent on the previous supply's arrival to a predetermined voltage, followed by a delay time that is 10µs or the DELAY pin's C1 value.

This sequencer monitors each power-supply voltage including V<sub>CC</sub>. When all the voltages reach the final value, the MAX16050 notifies the on-board processor. To anticipate unusual power-supply behavior, any supply voltage below its threshold will cause all voltage supplies to be turned off. During power-down, the outputs can be reverse-sequenced.

The MAX16050 monitors up to five voltages and sequences up to four voltages while the MAX16051, with basically the same functionality, monitors up to six voltages and sequences up to five voltages.

The positioning of the MAX16050/MAX16051 assists servers, workstations, networking systems, telecom equipment, and storage systems by offering ±1.5% high-accuracy threshold monitoring and capacitive-adjustable delays. The implementation of simple, multiple-channel sequencing is achieved without the help of firmware or software. These devices are in line with PCB size reduction activities in the small 4mm × 4mm dimensions of the 28-pin TQFN package. The wide 2.7V to 16V input range makes these devices effective power system solutions.

### Conclusion

The need for power in any circuit does not have to be an afterthought. Simple solutions range from discrete resistor-capacitor time delays for smaller systems to special-purpose integrated solutions that manage the power-up/power-down sequences and provide voltage monitoring. During the planning process, it is important to consider the various power-supply sequencing algorithms and apply an integrated solution. The MAX16050/MAX16051 voltage monitor and sequencer devices provide a simple, effective solution that brings peace of mind to the system power designer.

Learn more:

[MAX16050 Voltage Monitor/Sequencer Circuit with Reverse-Sequencing Capability](#)

[MAX16051 Voltage Monitor/Sequencer Circuit with Reverse-Sequencing Capability](#)

Design Solutions No. 108

Rev 0; April 2018

[Visit the Maxim Support Center](#)

[Find More Design Solutions](#)

**Maxim Integrated**  
160 Rio Robles  
San Jose, CA 95134 USA  
408-601-1000

[maximintegrated.com/design-solutions](http://maximintegrated.com/design-solutions)

