

DEBUR AND BREAK SHARP EDGES

DO NOT SCALE DRAWING

REVISION

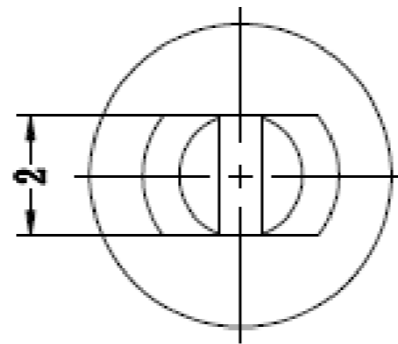
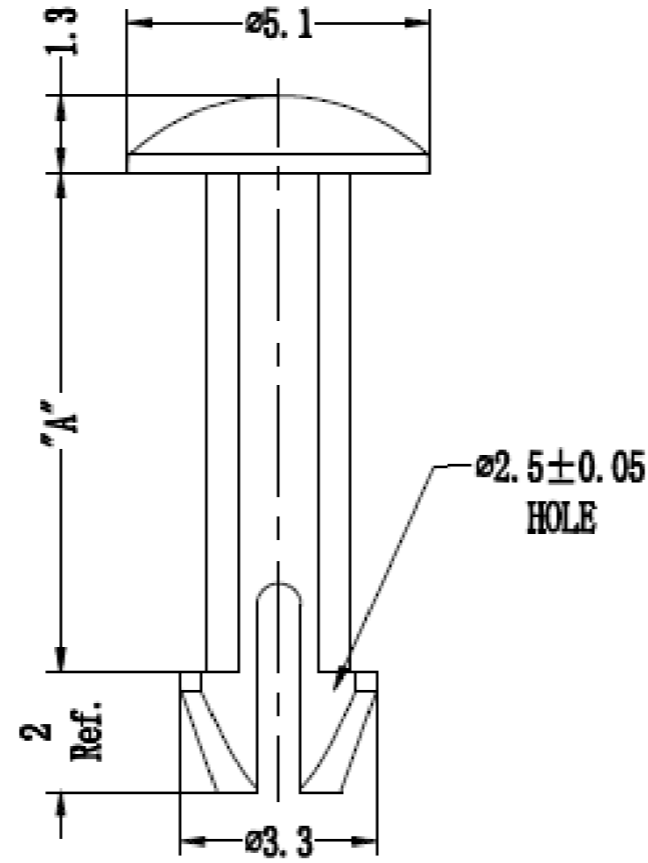

PART No.	HOLE DIA.	A
TRSLP-1-100-177-1	2.5 ± 0.05	4.50
TRSLP-1-100-221-1		5.60
TRSLP-1-100-236-1		6.00
TRSLP-1-100-245-1		6.22
TRSLP-1-100-307-1		7.80
TRSLP-1-100-316-1		8.02
TRSLP-1-100-330-1		8.38
TRSLP-1-100-413-1		10.50
TRSLP-1-100-638-1		16.20
TRSLP-1-100-660-1		16.76
TRSLP-1-100-701-1	17.80	

A DRAWN 01/11/13

NOTES

NOTES:

1. MATERIAL: Nylon 66UL94-2
2. COLOR: Natural;
3. ROHS Compliant;
4. Hole: $\varnothing 2.5 \pm 0.05\text{mm}$,
Panel Thickness: 2mm;



DESIGN RIGHT. TR FASTENINGS LTD, 2003
UNDER NO CIRCUMSTANCES MUST THIS
DRAWING BE COPIED OR DISCLOSED,
WITHOUT FIRST OBTAINING WRITTEN
AUTHORITY.

UNLESS OTHERWISE SPECIFIED:
DIMENSIONS ARE IN MILLIMETERS
SURFACE FINISH:
TOLERANCES:

ISO 2768 m	
NAME	DATE
DRAWN MARTIN ELLIOTT	01/11/13
CHK'D	
APPV'D	

CUSTOMER PART No

MATERIAL:

HEAT TREATMENT

FINISH:

TITLE:

SNAP LOCK PIN

DWG NO.

TRSLP-1-100

A3

PROJECTION

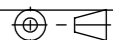

SHEET 1 OF 1