

DEBUR AND BREAK SHARP EDGES

DO NOT SCALE DRAWING

REVISION

Body

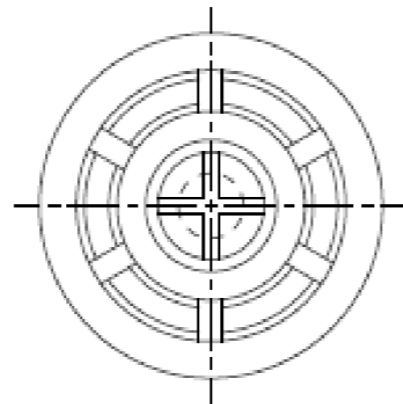
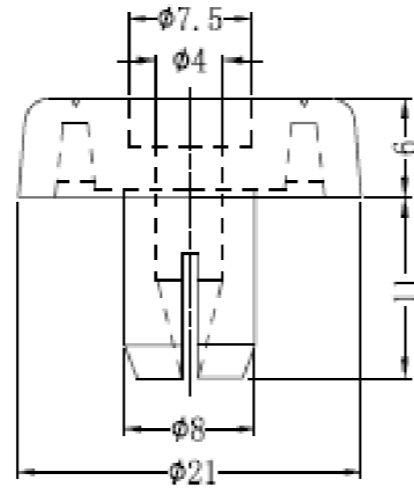

Pin

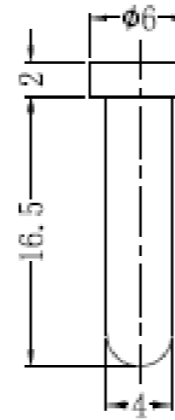

Assembly

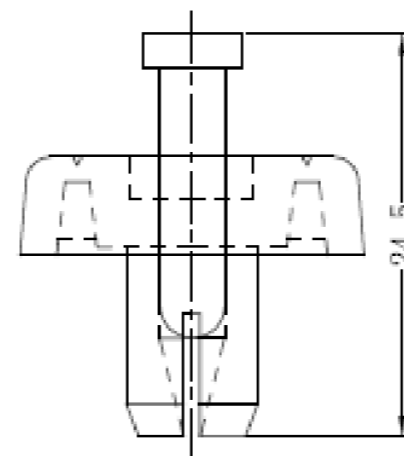

NOTES

- 1) MATERIAL - TPR UL94 HB (BODY)
- PP UL94 HB (PIN)
- 2) COLOUR - BLACK
- 3) ROHS COMPLIANT
- 4) HOLE DIA. 7.75mm
- 5) PANEL THICKNESS - 5.0-8.0mm



DESIGN RIGHT. TR FASTENINGS LTD, 2003
UNDER NO CIRCUMSTANCES MUST THIS
DRAWING BE COPIED OR DISCLOSED,
WITHOUT FIRST OBTAINING WRITTEN
AUTHORITY.

UNLESS OTHERWISE SPECIFIED:
DIMENSIONS ARE IN MILLIMETERS
SURFACE FINISH:
TOLERANCES:

NAME	DATE
DRAWN MARTIN ELLIOTT	09/06/14
CHK'D	
APPV'D	

PART No
TRSFF-021

MATERIAL:

SEE NOTES

HEAT TREATMENT

N/A

FINISH:

N/A

TITLE:

SOFT FAST FOOT

DWG NO.

TRSFF-021

A3

PROJECTION

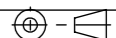

SHEET 1 OF 1