

DEBUR AND BREAK SHARP EDGES

DO NOT SCALE DRAWING

REVISION

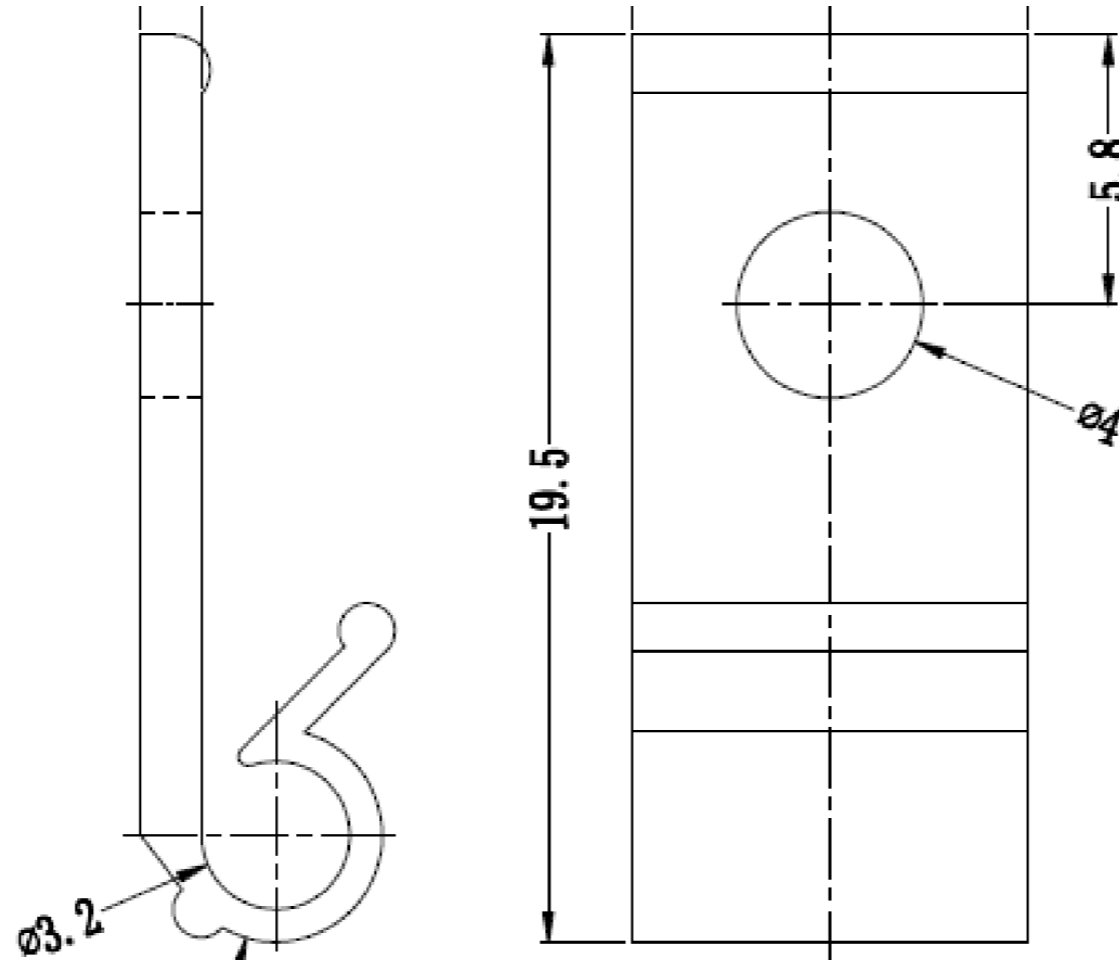

PART No.	BUNDLE DIA
TRWHC-125-01	3.2
TRWHC-250-01	6.4
TRWHC-375-01	9.5
TRWHC-500-01	12.7
TRWHC-625-01	15.9
TRWHC-750-01	19.1
TRWHC-1000-01	25.4
TRWHC-1500-01	38.1

C	Pt No. TABLE ADDED M.E. 26/06/14
B	DRG No.CHANGED M.E. 19/06/14
A	DRAWN 04/11/13

NOTES

- 1) MATERIAL:- NYLON 66 UL94V-2
- 2) COLOUR:- NATURAL
- 3) RoHS COMPLIANT
- 4) HOLE DIA- TRWHC-125-01 - 4.0mm
- 5) HOLE DIA - ALL OTHER SIZES - 5.2mm



DESIGN RIGHT. TR FASTENINGS LTD, 2003
UNDER NO CIRCUMSTANCES MUST THIS
DRAWING BE COPIED OR DISCLOSED,
WITHOUT FIRST OBTAINING WRITTEN
AUTHORITY.

UNLESS OTHERWISE SPECIFIED:
DIMENSIONS ARE IN MILLIMETERS
SURFACE FINISH:
TOLERANCES:

ISO 2768 m

NAME	DATE
DRAWN MARTIN ELLIOTT	04/11/13
CHK'D	
APPVD	

CUSTOMER PART No

MATERIAL:

SEE NOTES

HEAT TREATMENT

N/A

FINISH:

N/A

TITLE:

WIRE HARNESS CLAMP

DWG NO.

TRWHC-XXXX-01

A3

PROJECTION

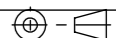

SHEET 1 OF 1