







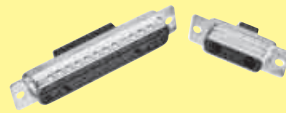

D-Sub – Mixed subminiature D connectors

Page

D-Sub mixed connector system – general information		04.02
Contact arrangements		04.03
Connectors for pcb applications – general information		04.04
Connectors for cable applications – general information		04.05
Technical characteristics for shells		04.06
Mixed shells with pre-mounted signal solder cup contacts		04.07
Shells without signal contacts for cable applications ..		04.14
Coded shells without signal contacts for cable applications.....		04.15
Mixed shells for signal crimp contacts		04.17
Technical characteristics for special contacts		04.21
Straight signal crimp contacts for cable applications		04.22
High voltage contacts for cable applications		04.23
Straight power contacts for cable applications		04.24
Coaxial contacts for cable applications		04.26
Pneumatic contacts for cable applications		04.29
Pcb hole patterns		04.30
Board drillings for connectors with straight pcb contacts		04.30
Board drillings for connectors with right angled pcb contacts		04.35
Customer request form for pcb connectors		04.40
Customer request form for cable connectors		04.42

HARTINGs' mixed D-Sub range brings the advantage of an industry standard I/O interconnect product with the possibility to customise for any application.

The range is designed around **the standard D-Sub shell sizes** with **the possibility to have a blend of contacts** such as signals with coaxial, power, high voltage or pneumatic contacts. Due to its construction, the product is **fully shielded** and helps reducing the EMI/RFI leakage.

All contacts are machined with two different platings.

When hot plug-in is required, **first mate last break** contacts can also be supplied.

For connectors to be fitted on a board with SMT components, they can be supplied in an **SMC (PiHIR) version** which is assembled in the reflow solder process, thus reducing assembly cost.

In addition, a complete range of accessories such as clinch nut, spacers, board locks, female screw lock, etc. ... meeting the requirements of virtually any application, including a blind mate feature, makes this product range very attractive thanks to its versatility, reliability and cost effectiveness.



Contact arrangements

The table shows the standard range supported by HARTING. Two versions are special since they allow to mix in the same shell male and female contacts: 2W2C and 3W3C. The purpose of these versions is to have a 100 % mating proof feature (the insulator shape prevents a 180° reversed mating).

The structure of the connectors' identification is so that the left side digits give the total number of contacts and the right side digits the number of special contacts which can be either power, coaxial or high voltage style.

Example: 13W3 stands for 13 contacts in total with 10 signal contacts and 3 special contacts.

	Shell size	
2W2C	1	
5W1	1	
3W3	2	
3W3C	2	
7W2	2	
11W1	2	
5W5	3	
9W4	3	
13W3	3	
17W2	3	
21W1	3	

	Shell size	
7W7	4	
8W8	4	
13W6	4	
21WA4	4	
25W3	4	
27W2	4	
24W7	5	
36W4	5	

Note:
for any other layout please consult your HARTING representative.

Connectors for pcb applications – general information

The range of pcb connectors available at HARTING is summarised in the table under. For each of the basic connector versions, the available contact styles are documented with termination process, pitch, plating, rating for power contacts and impedance for coaxial contact etc..., as well as the accessory configuration.

Pcb connectors are delivered fully loaded thus providing a very good positioning of the contacts in their cavities for an easy and safe insertion of the pins in the pcb holes particularly crucial in the right angled versions.



Due to the numerous possibilities offered with the pcb connectors, suggested method is to contact your local HARTING representative to determine the part number to order; see customer request form on pages 04.40 and 04.41.

	Straight		Right angled	
Insulator body	<ul style="list-style-type: none"> • Standard • SMC: Solder Reflow Compatible 		<ul style="list-style-type: none"> • Standard • SMC: Solder Reflow Compatible 	
Signal contacts	Solder termination <ul style="list-style-type: none"> • Pitch: 2.84 mm • Plating: 0.76 µm Au over Ni • Pcb thickness from 1.6 to 3.2 mm 		Solder termination <ul style="list-style-type: none"> • Pitch: 2.54 mm • Plating: 0.76 µm Au over Ni • Pcb thickness from 1.6 to 3.2 mm 	
Power contacts	Solder termination <ul style="list-style-type: none"> • Rating: 20, 30, 40 A • Plating: 0.76 µm Au over Ni Press-in termination <ul style="list-style-type: none"> • Rating: 30 A • Plating: 0.76 µm Au over Ni 		Solder termination <ul style="list-style-type: none"> • Rating: 20, 30, 40 A • Plating: 0.76 µm Au over Ni 	
Coaxial contacts	Solder termination <ul style="list-style-type: none"> • 50 or 75 Ω • Plating: 1.3 µm Au over Ni inner conductor 0.76 µm Au over Ni outer ring 		Solder termination <ul style="list-style-type: none"> • 50 or 75 Ω • Plating: 1.3 µm Au over Ni inner conductor 0.76 µm Au over Ni outer ring 	
Accessories	Through hole		Metal bracket with board lock and through hole	
	Nut: M3 or UNC 4-40		Metal bracket with board lock and clinch nut M3 or UNC 4-40	
	Spacer: M3 or UNC 4-40		Metal bracket with board lock and female screw lock UNC 4-40	
	Spacer (M3 or UNC 4-40) with board lock			
	Spacer + board lock + female screw lock M3 or UNC 4-40			

D-Sub - III

Connectors for cable applications – general information

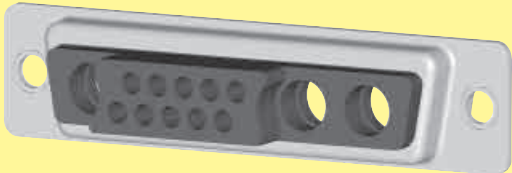
Two termination processes are available: crimp or solder

<p>Shell</p>		
<p>Signal contacts</p>	<p>Crimp termination</p> <ul style="list-style-type: none"> • For wire gauge: AWG 20-24 or 26-28 • Plating: 0.76 µm or 0.2 µm Au over Ni 	<p>Pre-mounted solder cup contacts</p> <ul style="list-style-type: none"> • Plating: 0.76 µm or 0.1 µm Au over Ni
<p>Power contacts</p>	<p>Crimp</p> <ul style="list-style-type: none"> • Rating: 10, 20, 30, 40 A • Plating: 0.76 µm or 0.2 µm Au over Ni <p>Solder cup</p> <ul style="list-style-type: none"> • Rating: 10, 20, 30, 40 A • Plating: 0.76 µm or 0.2 µm Au over Ni 	<p>Crimp</p> <ul style="list-style-type: none"> • Rating: 10, 20, 30, 40 A • Plating: 0.76 µm or 0.2 µm Au over Ni <p>Solder cup</p> <ul style="list-style-type: none"> • Rating: 10, 20, 30, 40 A • Plating: 0.76 µm or 0.2 µm Au over Ni
<p>Coaxial contacts¹⁾</p>	<p>Solder/crimp termination</p> <ul style="list-style-type: none"> • 50 or 75 Ω • Plating: 1.3 µm or 0.2 µm Au over Ni inner conductor • 0.76 µm or 0.2 µm Au over Ni outer ring • Cables: RG 178, 179 ... <p>Crimp/crimp termination</p> <ul style="list-style-type: none"> • 50 or 75 Ω • Plating: 1.3 µm or 0.2 µm Au over Ni inner conductor • 0.76 µm or 0.2 µm Au over Ni outer ring • Cables: RG 178, 179 ... 	<p>Solder/crimp termination</p> <ul style="list-style-type: none"> • 50 or 75 Ω • Plating: 1.3 µm or 0.2 µm Au over Ni inner conductor • 0.76 µm or 0.2 µm Au over Ni outer ring • Cables: RG 178, 179 ... <p>Crimp/crimp termination</p> <ul style="list-style-type: none"> • 50 or 75 Ω • Plating: 1.3 µm or 0.2 µm Au over Ni inner conductor • 0.76 µm or 0.2 µm Au over Ni outer ring • Cables: RG 178, 179 ...
<p>High voltage contacts</p>	<p>Solder termination</p> <ul style="list-style-type: none"> • Plating: 1.3 µm Au over Ni terminating and mating side 	<p>Solder termination</p> <ul style="list-style-type: none"> • Plating: 1.3 µm Au over Ni terminating and mating side

¹⁾ Coaxial contacts are provided in two versions:

- Inner conductor soldered and outer part crimped (solder/crimp termination)
- Both inner and outer part crimped (crimp/crimp termination); this version is recommended for medium or large size volume since crimping is faster than soldering.

Number of contacts 2, 3, 5, 7, 8, 9, 11, 13, 17, 21, 24, 25, 27, 36

Approvals DIN 41 652, part 1
MIL-C 24 308

Working current 5 A for signal contacts

Temperature range -55 °C ... + 125 °C
The higher temperature limit includes the ambient and heating effect of the contacts under load

Materials
Mouldings Thermoplastic resin, glass-fibre filled (Polyester)
UL 94-V0
color: green for standard
black for crimp

Metal shell Plated steel

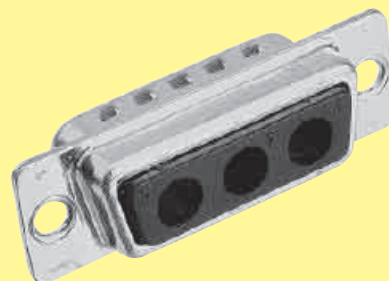
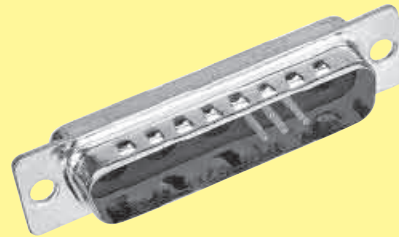

Number of contacts

7-27



Mixed shells with pre-mounted signal solder cup contacts

Identification	No. of contacts ¹⁾	Part No.			
		male connectors		female connectors	
		Performance level 3	S4 ²⁾	Performance level 3	S4 ²⁾
	7W2	09 69 211 7072	09 69 211 5072	09 69 201 7072	09 69 201 5072
	17W2	09 69 311 7172	09 69 311 5172	09 69 301 7172	09 69 301 5172
	21WA4	09 69 411 7214	09 69 411 5214	09 69 401 7214	09 69 401 5214
	27W2	09 69 411 7272	09 69 411 5272	09 69 401 7272	09 69 401 5272

Male connectors

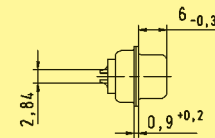
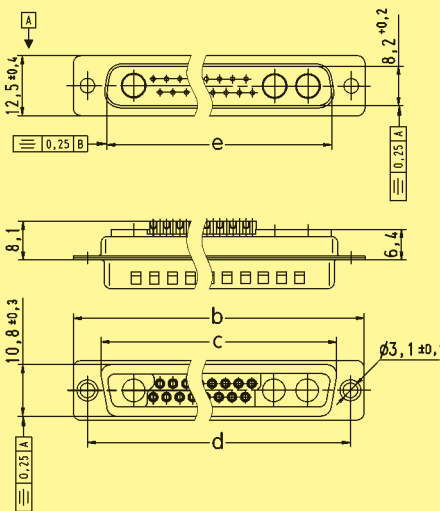

Solder cup termination for AWG 20 (0.5 mm²)

	a	b	c	d	e
7W2	24.6	39.1	27.5	33.30	25.2
17W2	38.3	53.0	41.3	47.04	38.9
21WA4	54.8	69.3	57.7	63.50	55.3
27W2	54.9	69.3	57.7	63.50	55.3

Female connectors

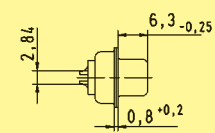
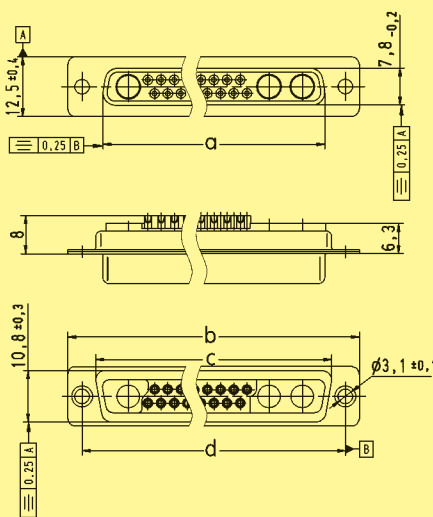

Solder cup termination for AWG 20 (0.5 mm²)

Dimensions in mm

¹⁾ Explanations see page 04.03
²⁾ S4: ≥ 0.76 µm Au

Board drillings see pages 04.30 ff
 Order special contacts separately. See pages 04.21 ff

D-Sub - M

Number of contacts

9-25

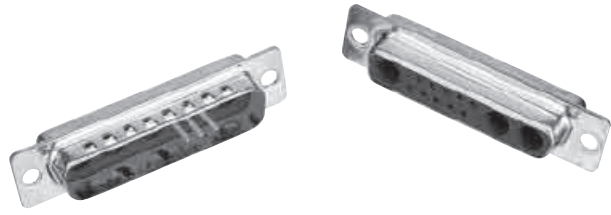

Mixed shells with pre-mounted signal solder cup contacts

Identification	No. of contacts ¹⁾	Part No.			
		male connectors		female connectors	
		Performance level 3	S4 ²⁾	Performance level 3	S4 ²⁾
	9W4	09 69 311 7094	09 69 311 5094	09 69 301 7094	09 69 301 5094
	13W3	09 69 311 7133	09 69 311 5133	09 69 301 7133	09 69 301 5133
	25W3	09 69 411 7253	09 69 411 5253	09 69 401 7253	09 69 401 5253

Male connectors

9W4

Solder cup termination for AWG 20 (0.5 mm²)

13W3, 25W3

Solder cup termination for AWG 20 (0.5 mm²)

	b	c	d	e
13W3	53.0	41.3	47.04	38.90
25W3	69.3	57.7	63.50	49.84

Dimensions in mm

D-Sub - M

¹⁾ Explanations see page 04.03
²⁾ S4: ≥ 0.76 μm Au
 Board drillings see pages 04.30 ff

Drawings for female connectors see page 04.09
 Order special contacts separately. See pages 04.21 ff

Number of contacts

9-25

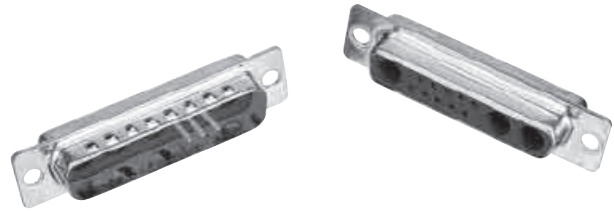

Mixed shells with pre-mounted signal solder cup contacts

Identification

Drawing

Dimensions in mm

Female connectors

9W4

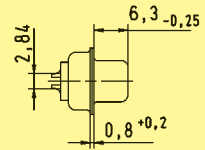
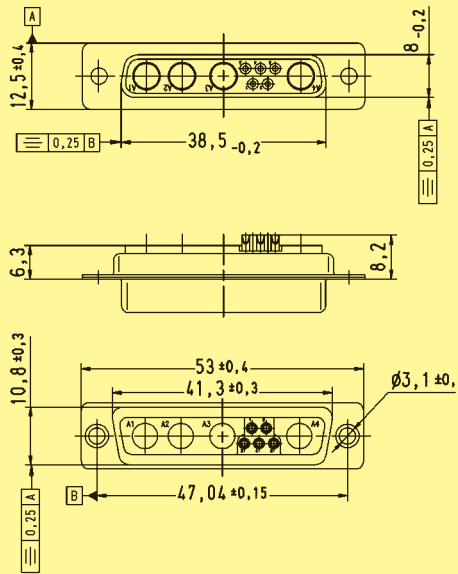

Solder cup termination for AWG 20 (0.5 mm²)

13W3, 25W3

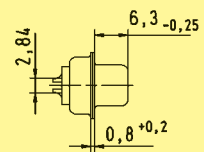
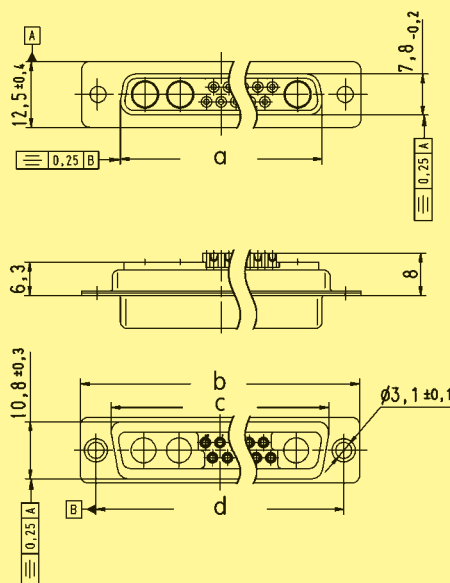

Solder cup termination for AWG 20 (0.5 mm²)

	a	b	c	d
13W3	38.3	53.0	41.3	47.04
25W3	54.9	69.3	57.7	63.50

D-Sub - M

Number of contacts

5-21



Mixed shells with pre-mounted signal solder cup contacts

Identification	No. of contacts ¹⁾	Part No.			
		male connectors		female connectors	
		Performance level 3	S4 ²⁾	Performance level 3	S4 ²⁾
	5W1	09 69 111 7051	09 69 111 5051	09 69 101 7051	09 69 101 5051
	11W1	09 69 211 7111	09 69 211 5111	09 69 201 7111	09 69 201 5111
	21W1	09 69 311 7211	09 69 311 5211	09 69 301 7211	09 69 301 5211

Male connectors

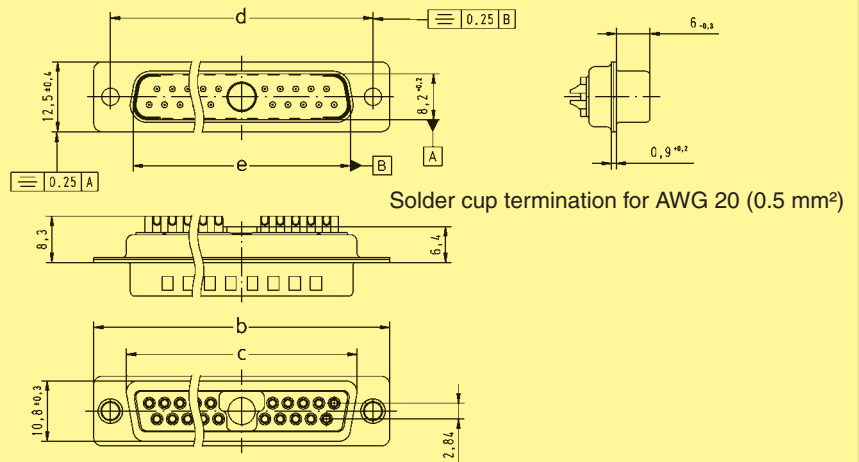

Female connectors

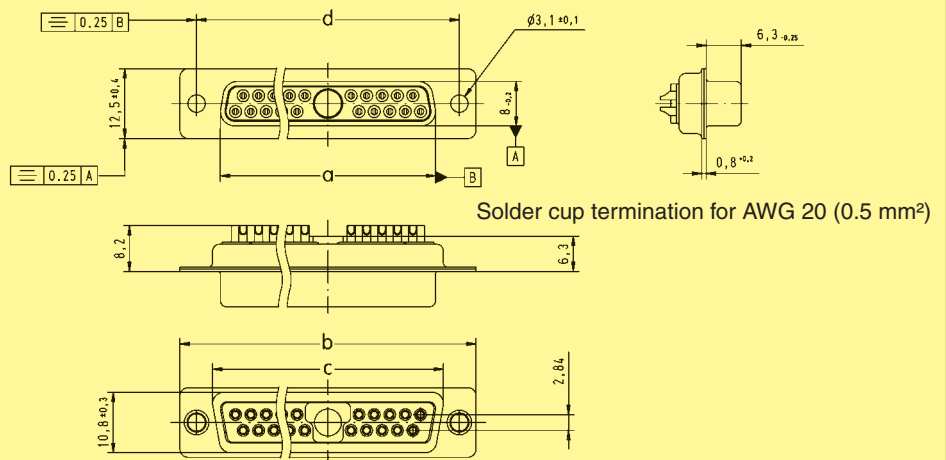

	a	b	c	d	e
5W1	16.4	30.8	19.3	25.00	16.9
11W1	24.7	39.1	27.5	33.30	25.2
21W1	38.5	53.0	41.3	47.04	38.9

Dimensions in mm

¹⁾ Explanations see page 04.03
²⁾ S4: ≥ 0.76 μm Au
 Board drillings see pages 04.30 ff

Order special contacts separately. See pages 04.21 ff

Number of contacts

13



Mixed shells with pre-mounted signal solder cup contacts

Identification	No. of contacts ¹⁾	Part No.			
		male connectors		female connectors	
		Performance level 3	S4 ²⁾	Performance level 3	S4 ²⁾
	13W6	09 69 411 7136	09 69 411 5136	09 69 401 7136	09 69 401 5136

Male connectors

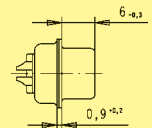
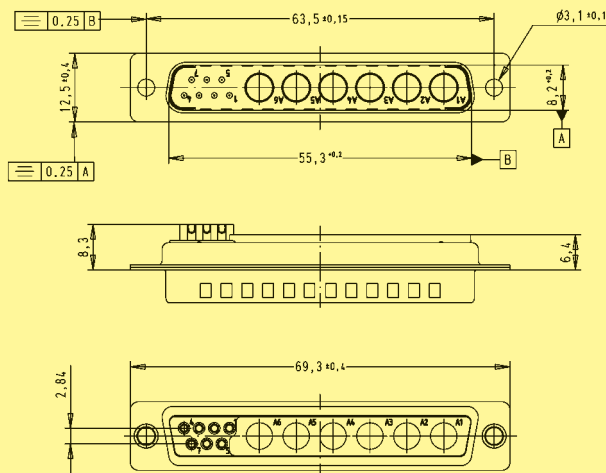

Solder cup termination for AWG 20 (0.5 mm²)

Female connectors

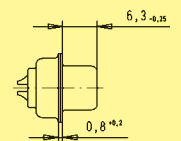
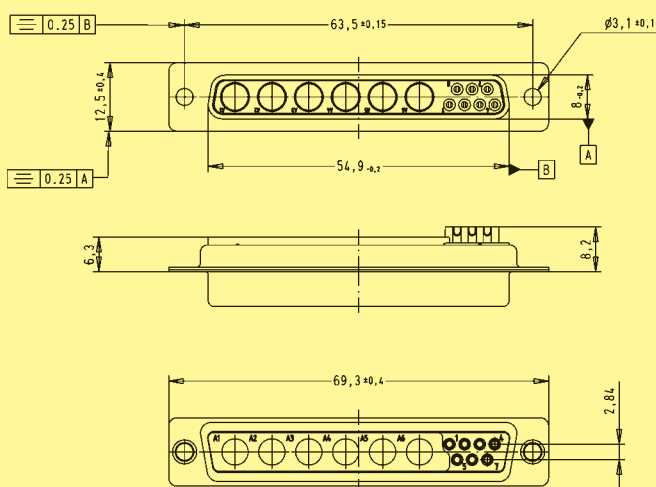

Solder cup termination for AWG 20 (0.5 mm²)

Dimensions in mm

¹⁾ Explanations see page 04.03
²⁾ S4: ≥ 0.76 μm Au
 Board drillings see pages 04.30 ff

Order special contacts separately. See pages 04.21 ff

D-Sub - M

Number of contacts

24



Mixed shells with pre-mounted signal solder cup contacts

Identification	No. of contacts ¹⁾	male connectors		female connectors	
		Performance level 3	S4 ²⁾	Performance level 3	S4 ²⁾
24W7		09 69 511 7247	09 69 511 5247	09 69 501 7247	09 69 501 5247

D-Sub - M



Male connectors

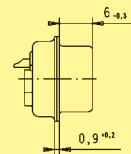
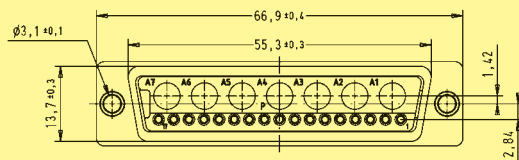
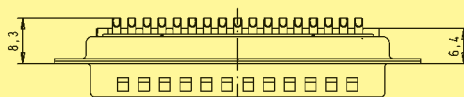
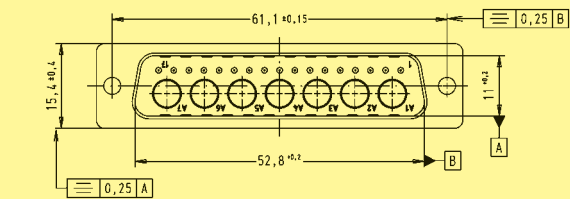

Solder cup termination for AWG 20 (0.5 mm²)

Female connectors

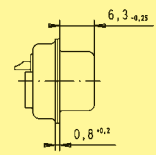
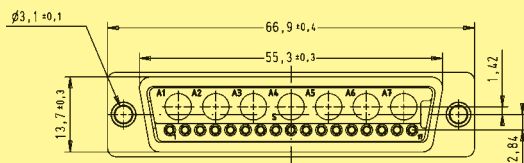
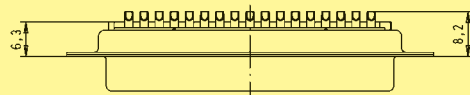
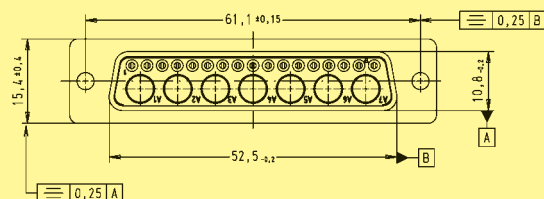

Solder cup termination for AWG 20 (0.5 mm²)

Dimensions in mm

¹⁾ Explanations see page 04.03
²⁾ S4: ≥ 0.76 μm Au
 Board drillings see pages 04.30 ff

Order special contacts separately. See pages 04.21 ff

Number of contacts

36



Mixed shells with pre-mounted signal solder cup contacts

Identification	No. of contacts ¹⁾	Part No.			
		male connectors		female connectors	
		Performance level 3	S4 ²⁾	Performance level 3	S4 ²⁾
36W4		09 69 511 7364	09 69 511 5364	09 69 501 7364	09 69 501 5364

Male connectors

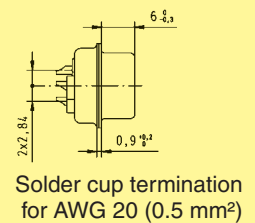
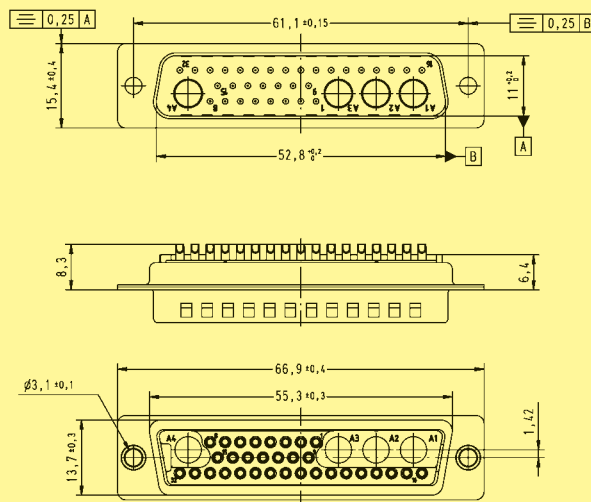

Female connectors

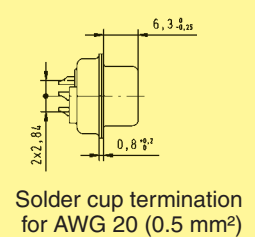
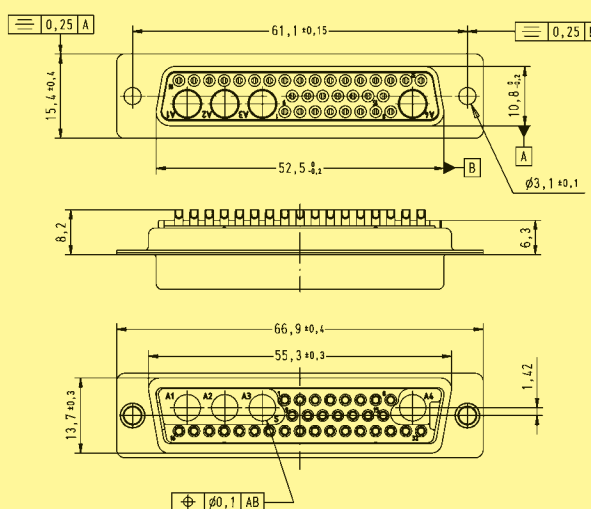

Dimensions in mm

¹⁾ Explanations see page 04.03
²⁾ S4: ≥ 0.76 μm Au
 Board drillings see pages 04.30 ff

Order special contacts separately. See pages 04.21 ff

D-Sub - M

Number of contacts

3-8

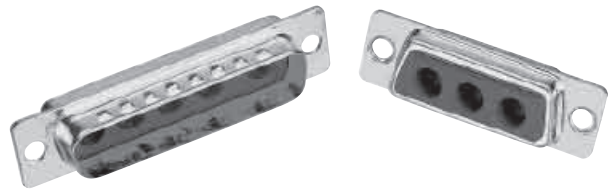

Shells without signal contacts for cable applications

Identification	No. of contacts ¹⁾	Part No.	
		male connectors	female connectors
	3W3	09 69 210 0033	09 69 200 0033
	5W5	09 69 310 0055	09 69 300 0055
	7W7	09 69 410 0077	09 69 400 0077
	8W8	09 69 410 0088	09 69 400 0088

D-Sub - M

Male connectors

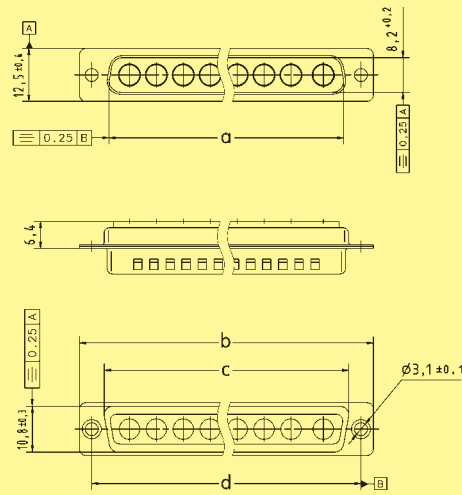

	a	b	c	d	e
3W3	25.2	39.1	27.5	33.30	24.6
5W5	38.9	53.0	41.3	47.04	38.3
7W7	55.3	69.3	57.7	63.50	54.9
8W8	55.3	69.3	57.7	63.50	54.8

Female connectors

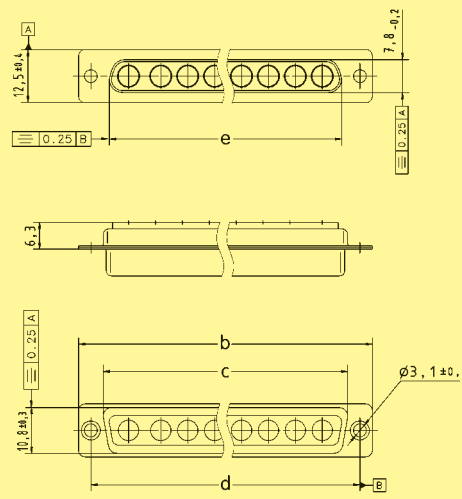

Dimensions in mm

¹⁾ Explanations see page 04.03
 Board drillings see pages 04.30 ff
 Order special contacts separately. See pages 04.21 ff

Number of contacts

2



Coded shells without signal contacts for cable applications

Identification	No. of contacts ¹⁾	Part No.	
		male connector	female connector
	2W2C	09 69 110 0022	09 69 100 0022

Male connectors

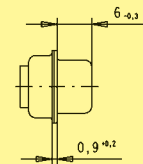
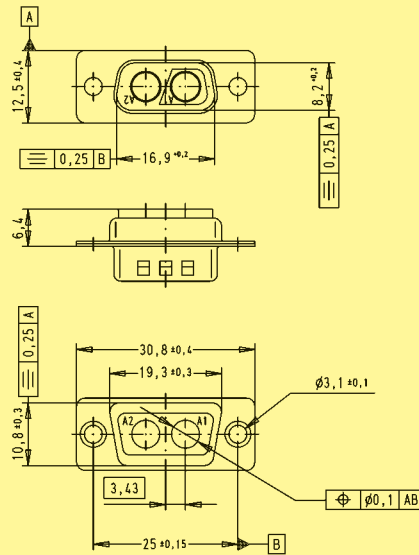

Female connectors

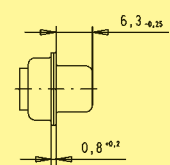
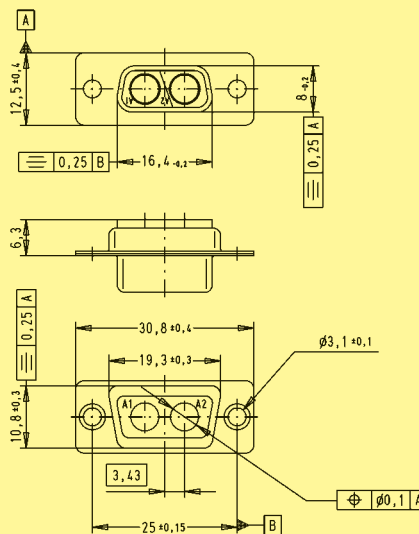

Dimensions in mm

¹⁾ Explanations see page 04.03
 Board drillings see pages 04.30 ff
 Order special contacts separately. See pages 04.21 ff

Number of contacts

3



Coded shells without signal contacts for cable applications

Identification	No. of contacts ¹⁾	Part No.	
		male connector	female connector
	3W3C	09 69 210 0633	09 69 200 0633

Male connectors

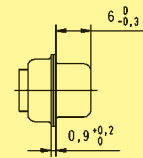
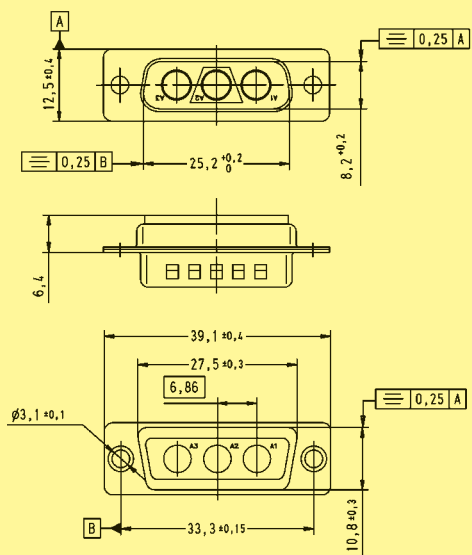

detail: polarization feature

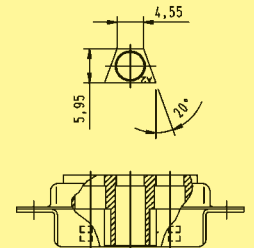

Female connectors

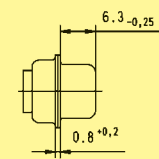
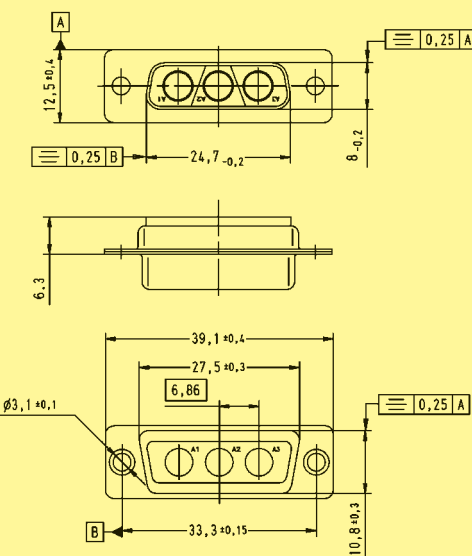

detail: polarization feature

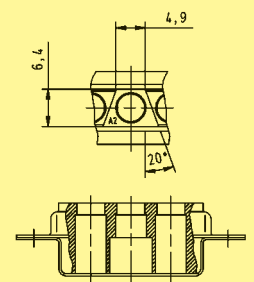

Dimensions in mm

¹⁾ Explanations see page 04.03
Board drillings see pages 04.30 ff
Order special contacts separately. See pages 04.21 ff

Number of contacts

7-21

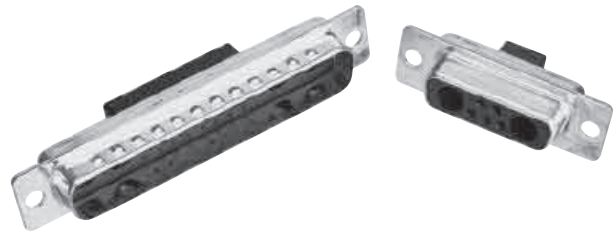

Mixed shells for signal crimp contacts

Identification	No. of contacts ¹⁾	Part No.	
		male connectors	female connectors
	7W2	09 69 212 0072	09 69 202 0072
	17W2	09 69 312 0172	09 69 302 0172
	21WA4	09 69 412 0214	09 69 402 0214

D-Sub - M

Male connectors

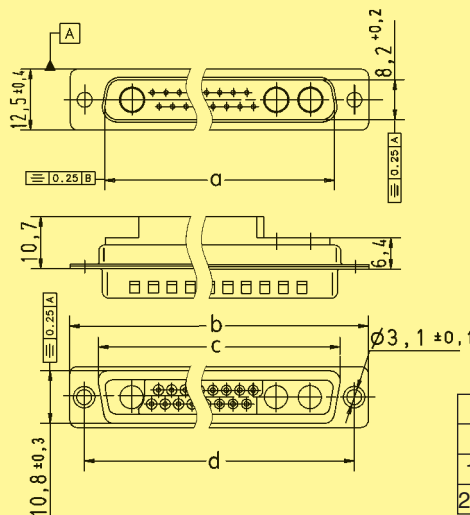

Female connectors

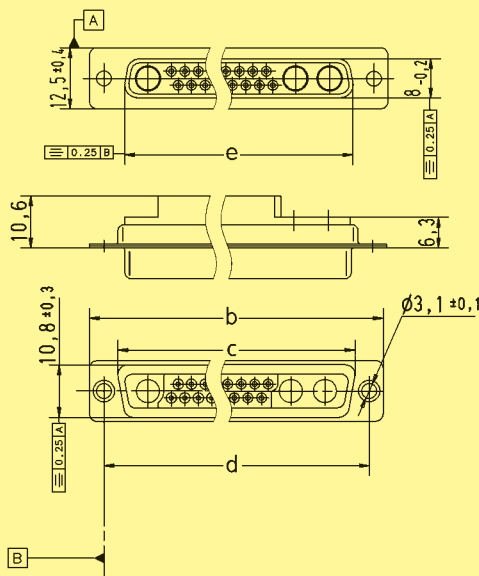

Dimensions in mm

¹⁾ Explanations see page 04.03
 Board drillings see pages 04.30 ff
 Order special contacts separately. See pages 04.21 ff

Number of contacts

13



Mixed shells for signal crimp contacts

Identification	No. of contacts ¹⁾	Part No.	
		male connector	female connector
	13W3	09 69 312 0133	09 69 302 0133

D-Sub - M

Male connectors

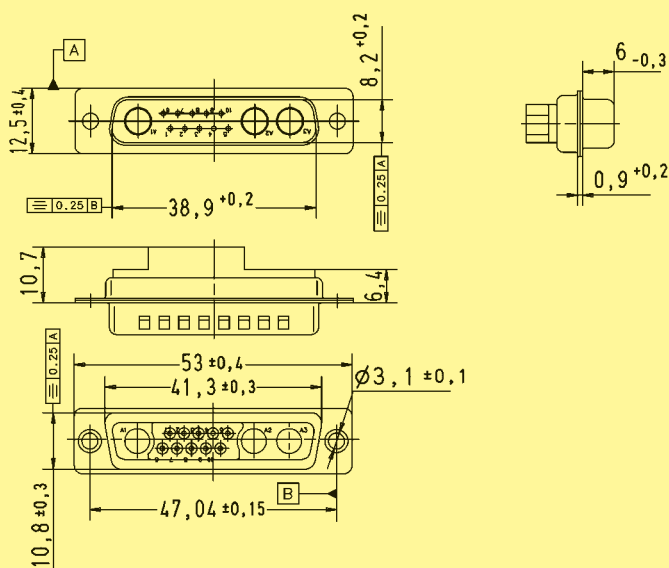

Female connectors

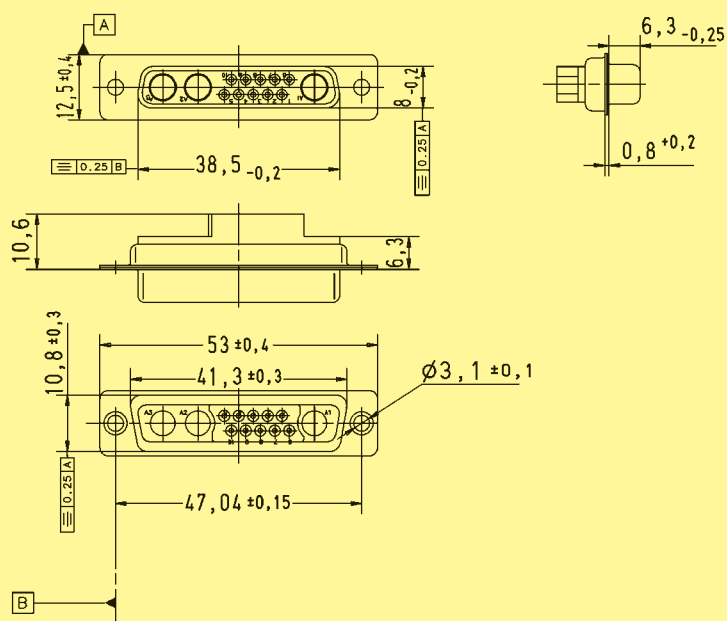

Dimensions in mm



¹⁾ Explanations see page 04.03
 Board drillings see pages 04.30 ff
 Order special contacts separately. See pages 04.21 ff

Number of contacts

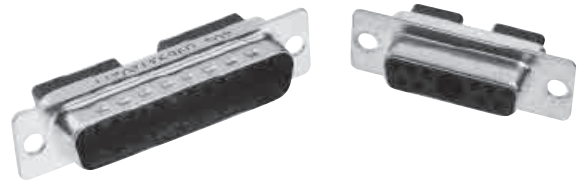
11-21



Mixed shells for signal crimp contacts

Identification	No. of contacts ¹⁾	Part No.	
		male connectors	female connectors
	11W1	09 69 212 0111	09 69 202 0111
	21W1	09 69 312 0211	09 69 302 0211

Male connectors

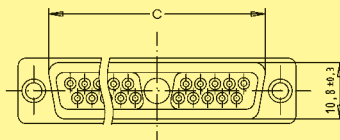
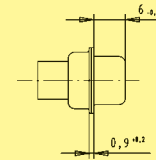
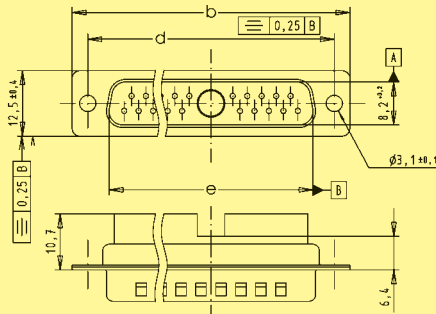

	a	b	c	d	e
11W1	24.7	39.1	27.5	33.30	25.2
21W1	38.5	53.0	41.3	47.04	38.9

Female connectors

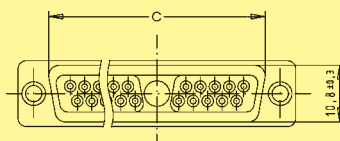
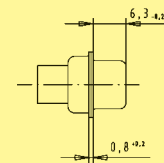
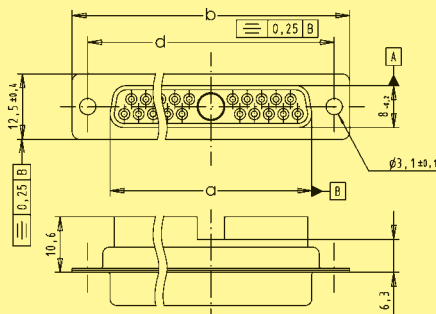

Dimensions in mm

¹⁾ Explanations see page 04.03
 Order special contacts separately. See pages 04.21 ff
 Board drillings see pages 04.30 ff

Number of contacts

36



Mixed shells for signal crimp contacts

Identification	No. of contacts ¹⁾	Part No.
		male connector
		female connector
	36W4	09 69 512 0364
		09 69 502 0364

D-Sub - M

Male connectors

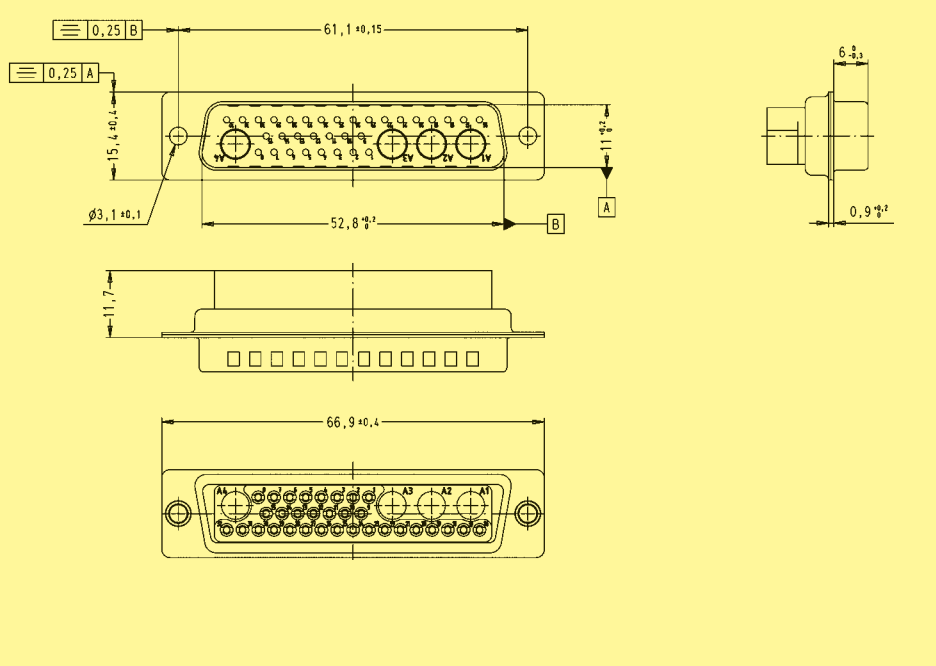

Female connectors

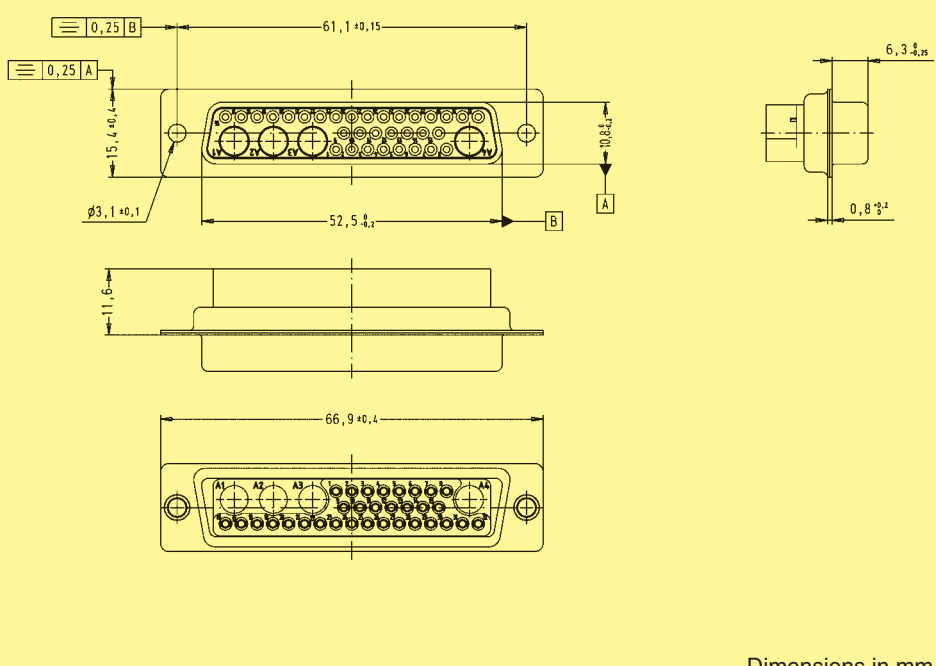

Dimensions in mm

¹⁾ Explanations see page 04.03
 Board drillings see pages 04.30 ff
 Order special contacts separately. See pages 04.21 ff

	Signal contacts see page 04.22	Coaxial contacts see pages 04.26 – 04.28	Power contacts see pages 04.24 + 04.25	High voltage contacts see page 04.23	Pneumatic contacts see page 04.29
Working current	5 A	2 A	10 A, 20 A, 30 A or 40 A	2 A DC	–
Test voltage $U_{r.m.s.}$	–	750 V / 50 Hz	–	4 kV / 50 Hz	–
Operating voltage	–	–	–	≤ 3 kV	–
Contact resistance	–	≤ 2.7 mΩ (inner and outer conductor)	≤ 1 mΩ	≤ 3 mΩ (outer conductor)	–
Impedance	–	50 / 75 Ω	–	–	–
Frequency range	–	0 - 2 GHz	–	–	–
Temperature range	–	-55 °C ... + 135 °C	-55 °C ... + 155 °C	-55 °C ... + 125 °C	-10 °C ... + 60 °C
Mating cycles					
high performance level	≥ 500	≥ 500	≥ 500	–	–
standard performance level	≥ 200	≥ 200	≥ 200	≥ 500	–
Mating force	≤ 3.4 N	≤ 7 N/mated pair	≤ 7 N/mated pair	≤ 5 N	–
Unmating force	≥ 0.2 N	≤ 7 N/mated pair	appr. 5 N	appr. 2.5 N	–
Max. pressure	–	–	–	–	7 bars at 20 °C
Materials					
Contacts	Copper alloy	Copper alloy	Copper alloy	Copper alloy	German silver
Plating*					
Mating side / terminating side	0.76 μm Au / 0.76 μm Au or 0.2 μm Au / 0.2 μm Au		0.76 μm Au / 0.2 μm Au or 0.2 μm Au / 5 μm Sn	1.3 μm Au / 1.3 μm Au	–
Inner conductor mating side / terminating side	–	1.3 μm Au / 1.3 μm Au or 0.2 μm Au / 0.2 μm Au	–	–	–
Outer conductor mating side / terminating side	–	0.76 μm Au / 0.2 μm Au or 0.2 μm Au / 5 μm Sn	–	–	–
Retaining clip	–	Copper alloy	Copper alloy	PI	–
Insulator	–	PBFE/PBTP/PI	–	PTFE	–
O-ring	–	–	–	–	Vitton

Technical characteristics for shells see page 04.06
* **High performance** or standard performance level



Straight signal crimp contacts for cable applications

Identification	Wire gauge (mm ²)	Part No.	
		Performance level 3	S4 ¹⁾
Male contact	0.09 - 0.14 AWG 28 - 26	09 69 282 7311	09 69 282 5311
	0.25 - 0.56 AWG 24 - 20	09 69 282 7310	09 69 282 5310
Female contact	0.09 - 0.14 AWG 28 - 26	09 69 182 7311	09 69 182 5311
	0.25 - 0.56 AWG 24 - 20	09 69 182 7310	09 69 182 5310

Male contact

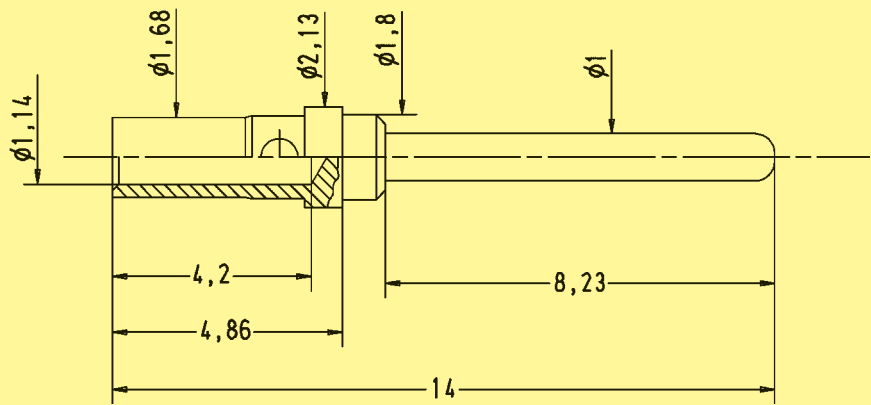

Female contact

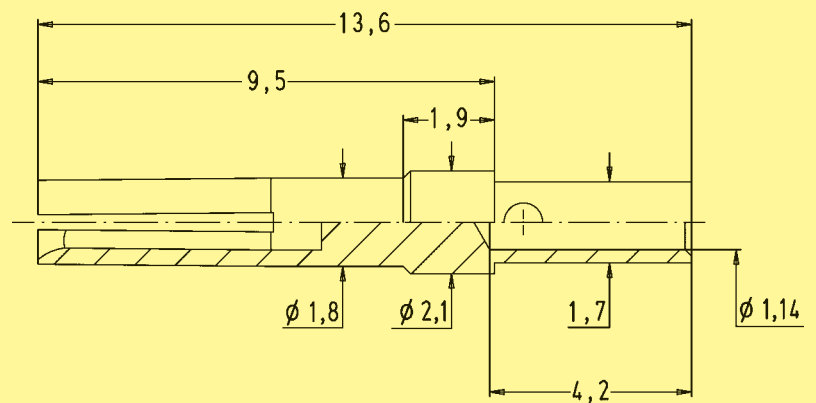

Dimensions in mm

D-Sub - M

¹⁾ S4: ≥ 0.76 μm Au
Tooling see chapter 31



High voltage contacts for cable applications

Identification	Wire gauge (mm ²)	Part No.	
Straight versions	0.25 - 0.56 AWG 24 - 20	Male contacts Plating: 1.3 µm Au ¹⁾	Female contacts Plating: 1.3 µm Au ¹⁾
		09 69 281 2550	09 69 181 2550
Right angled versions	0.25 - 0.56 AWG 24 - 20	09 69 681 2550	09 69 581 2550

D-Sub - M

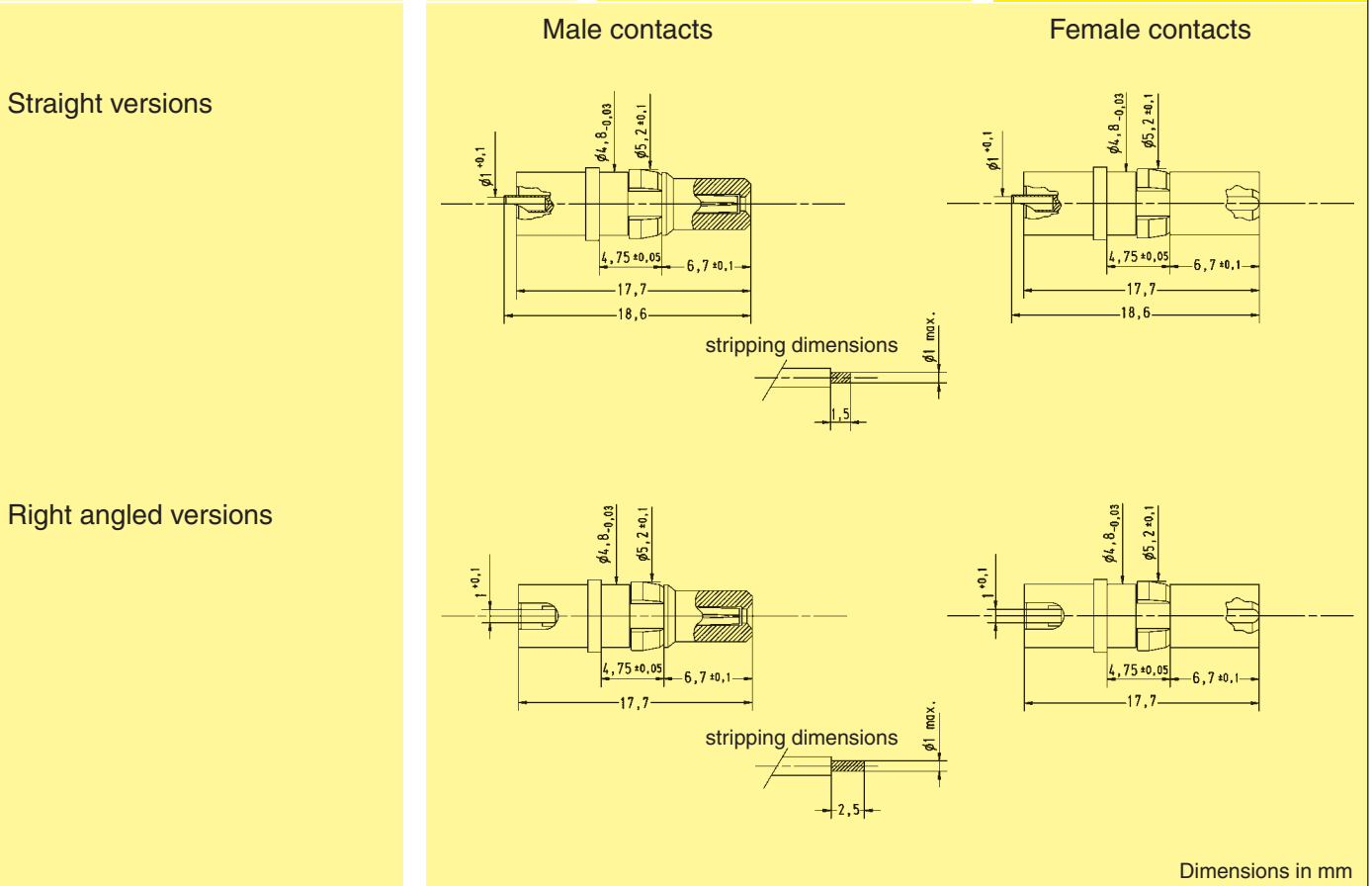

Dimensions in mm

¹⁾ for mating and terminating side



Straight power contacts for cable applications

Identification	Rating (A)	Part No.	
Performance levels		Performance level 3	S4 ¹⁾
Solder version			
Male contacts	10 20 30 40	09 69 281 7420 09 69 281 7421 09 69 281 7422 09 69 281 7423	09 69 281 5420 09 69 281 5421 09 69 281 5422 09 69 281 5423
Female contacts	10 20 30 40	09 69 181 7420 09 69 181 7421 09 69 181 7422 09 69 181 7423	09 69 181 5420 09 69 181 5421 09 69 181 5422 09 69 181 5423
Crimp version ²⁾			
Male contacts	10 20 30 40	09 69 282 7420 09 69 282 7421 09 69 282 7422 09 69 282 7423	09 69 282 5420 09 69 282 5421 09 69 282 5422 09 69 282 5423
Female contacts	10 20 30 40	09 69 182 7420 09 69 182 7421 09 69 182 7422 09 69 182 7423	09 69 182 5420 09 69 182 5421 09 69 182 5422 09 69 182 5423

D-Sub - M

¹⁾ S4: ≥ 0.76 µm Au
²⁾ Tooling see chapter 31
 Dimensions see page 04.25



Straight power contacts for cable applications

Identification

Drawing

Dimensions in mm

Male contacts

solder

crimp

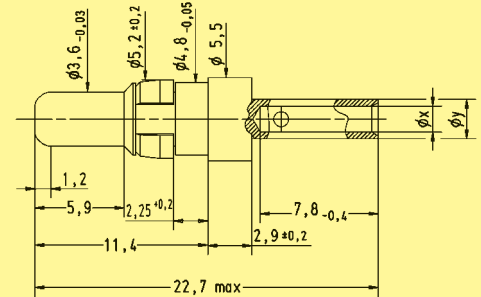
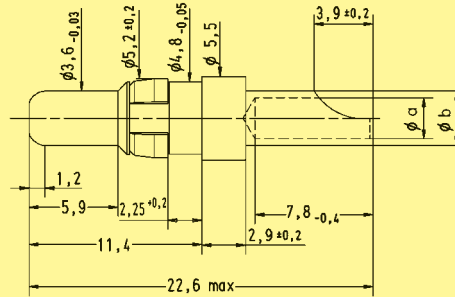

stripping dimensions

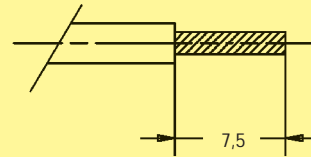

Rating (A)	$\phi a -0.1$	$\phi b \pm 0.05$
10	1.8	2.54
20	2.7	3.63
30	3.5	4.40
40	4.8	5.50

Rating (A)	$\phi x -0.1$	$\phi y \pm 0.05$	AWG
10	1.7	2.6	16 - 20
20	2.6	3.6	12 - 14
30	3.7	4.7	10 - 12
40	4.6	5.8	8 - 10

Female contacts

solder

crimp

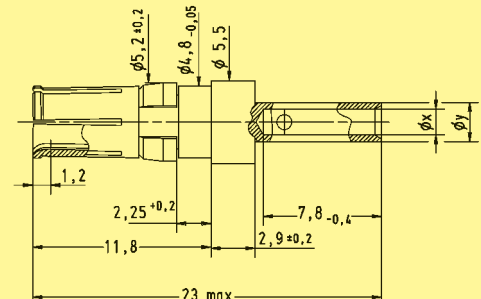
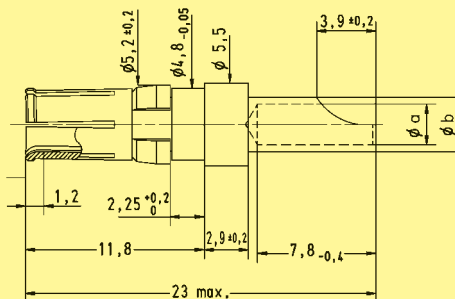

stripping dimensions

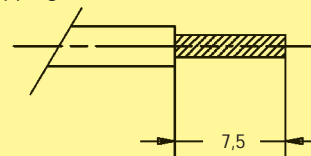



Coaxial contacts for cable applications

Identification	Impedance (Ω)	Part No.			
		Straight male contacts		Straight female contacts	
		Performance level 3	S4 ¹⁾	Performance level 3	S4 ¹⁾
Solder / crimp contact					
for cables RG 174 U, 188 AU, 316 U	50	09 69 281 7140	09 69 281 5140	09 69 181 7140	09 69 181 5140
for cables RG 178 BU, 196 AU, 404 U	50	09 69 281 7141	09 69 281 5141	09 69 181 7141	09 69 181 5141
for cables RG 58 CU, 141 AU	50	09 69 281 7143	09 69 281 5143	09 69 181 7143	09 69 181 5143
for cables RG 179 BU, 187 AU	75	09 69 281 7230	09 69 281 5230	09 69 181 7230	09 69 181 5230
for cables RGD 179	75	09 69 281 7233	09 69 281 5233	09 69 181 7233	09 69 181 5233
Crimp / crimp contact					
for cables RG 174 U, 188 AU, 316 U	50	09 69 282 7140	09 69 282 5140	09 69 182 7140	09 69 182 5140
for cables RG 179 BU, 187 AU	75	09 69 282 7230	09 69 282 5230	09 69 182 7230	09 69 182 5230
for cables RG 59	75	09 69 282 7232	09 69 282 5232	09 69 182 7232	09 69 182 5232
for cables RGD 179	75	09 69 282 7233	09 69 282 5233	09 69 182 7233	09 69 182 5233

Harnessing dimensions (mm)

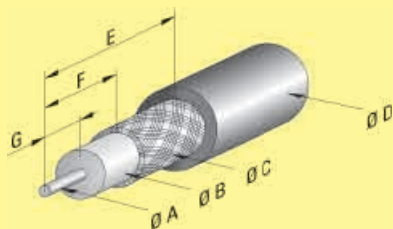

Part No.	Ø A	Ø B	Ø C	Ø D	E	F	G
09 69 181 x140 09 69 281 x140	0.85	1.9	2.3	3.2	9.5	5.0	3.0
09 69 181 x141 09 69 281 x141	0.85	1.2	1.4	2.3	9.5	5.0	3.0
09 69 181 x143 09 69 281 x143	1.00	3.0	4.4	5.2	9.5	5.0	3.0
09 69 181 x230 09 69 281 x230	0.50	1.9	2.3	3.2	9.5	5.0	3.0
09 69 182 x140 09 69 282 x140	0.60	1.9	2.4	3.2	9.0	5.0	3.0
09 69 182 x230 09 69 282 x230	0.60	1.9	2.4	3.2	9.0	5.0	3.0
09 69 182 x232 09 69 282 x232	0.95	3.8	5.1	6.2	9.0	4.3	3.7
09 69 181 x233 09 69 281 x233	0.50	1.9	2.6	3.5	9.5	5.0	3.0
09 69 182 x233 09 69 282 x233	0.60	1.9	2.6	3.5	9.3	4.3	3.0

¹⁾ S4: ≥ 0.76 µm Au
Dimensions see pages 04.27 and 04.28
Tooling see chapter 31

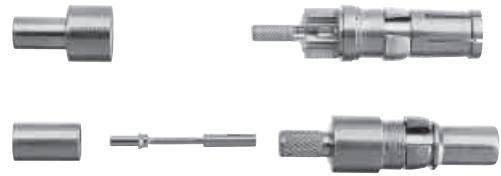

Coaxial contacts for cable applications

Identification

Drawing

Dimensions in mm

Male contacts

Part No.	ø a	ø b	ø c	ø d
09 69 281 x140	0.85	1.9	2.6	3.2
09 69 281 x141	0.85	1.2	1.7	2.3
09 69 281 x230	0.50	1.9	2.6	3.2

Part No.	ø a	ø b	ø c	ø d
09 69 281 x143	1.0	3.0	4.4	5.2

Part No.	ø a	ø b	ø c	ø d
09 69 281 x233	0.5	1.9	2.6	3.5

Part No.	ø a	ø b	ø c	ø d	ø e
09 69 282 x140	0.6	1.9	2.6	3.2	3.8
09 69 282 x230	0.6	1.9	2.6	3.2	3.8
09 69 282 x233	0.6	1.9	2.6	3.5	4.4

Part No.	ø a	ø b	ø c	ø d
09 69 282 x232	0.95	3.8	5.1	6.2

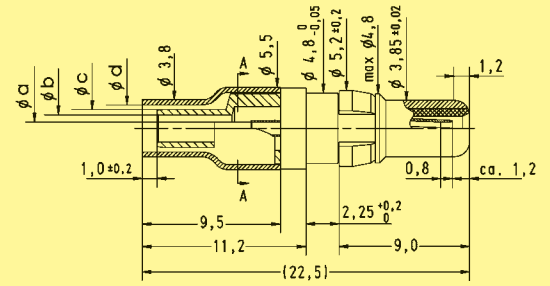

Points of plating thickness measurement

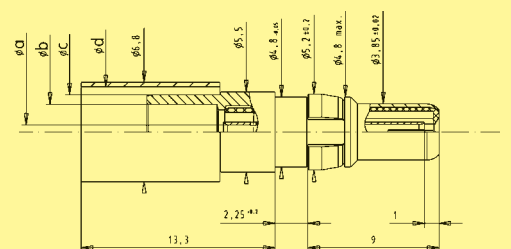
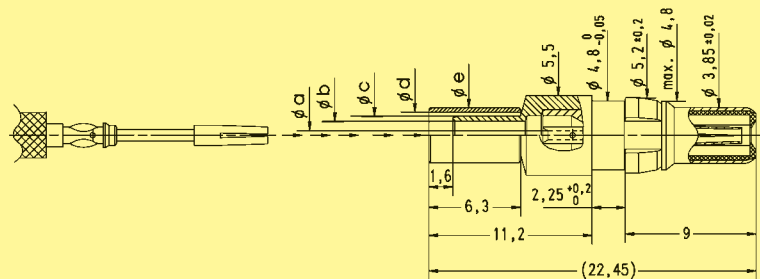
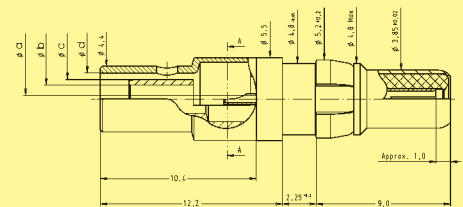
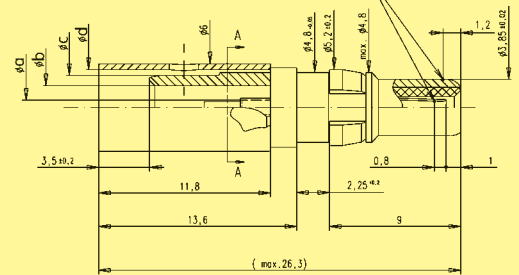

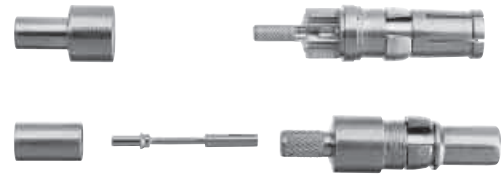

Coaxial contacts for cable applications

Identification

Drawing

Dimensions in mm

Female contacts

Part No.	ø a	ø b	ø c	ø d
09 69 181 x140	0.85	1.9	2.6	3.2
09 69 181 x141	0.85	1.2	1.7	2.3
09 69 181 x230	0.50	1.9	2.6	3.2

Part No.	ø a	ø b	ø c	ø d
09 69 181 x143	1.0	3.0	4.4	5.2

Part No.	ø a	ø b	ø c	ø d
09 69 181 x233	0.5	1.9	2.6	3.5

Part No.	ø a	ø b	ø c	ø d	ø e
09 69 182 x140	0.6	1.9	2.6	3.2	3.8
09 69 182 x230	0.6	1.9	2.6	3.2	3.8
09 69 182 x233	0.6	1.9	2.6	3.5	4.4

Part No.	ø a	ø b	ø c	ø d
09 69 182 x232	0.95	3.8	5.1	6.2

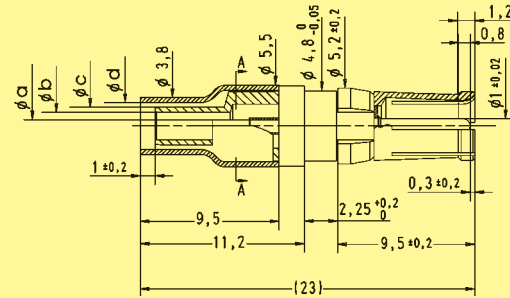

Points of plating thickness measurement

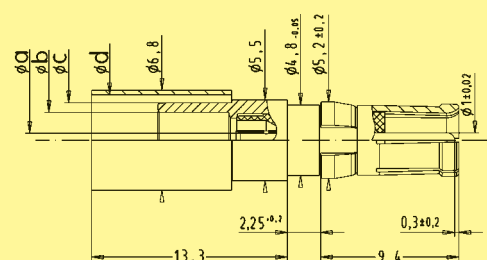
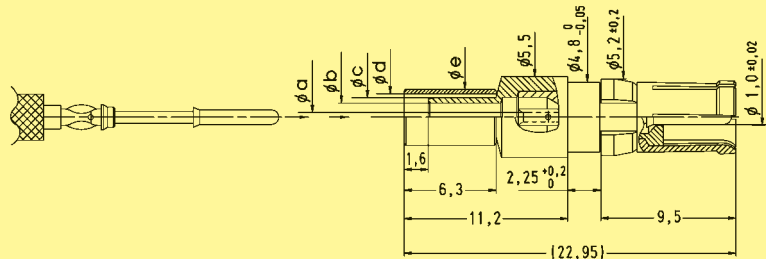
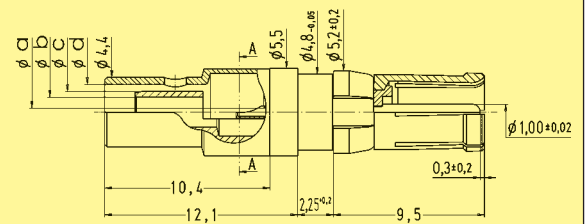
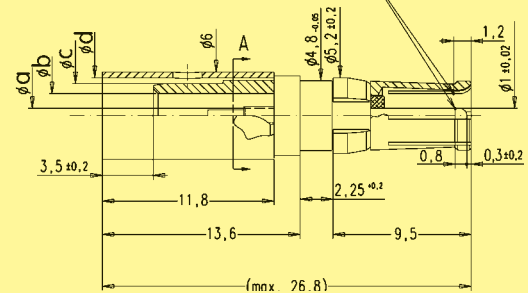

D-Sub - M

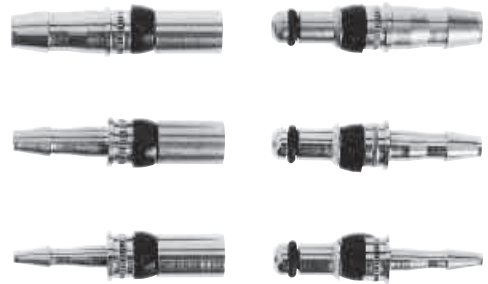

Pneumatic contacts for cable applications

Identification	Inner diameter air tube (mm)	Part No.
Male contacts	2	09 69 287 0061
	2.6	09 69 287 0060
	3	09 69 287 0062
	4	09 69 287 0063
Female contacts	2	09 69 187 0061
	2.6	09 69 187 0060
	3	09 69 187 0062
	4	09 69 187 0063

Male contacts

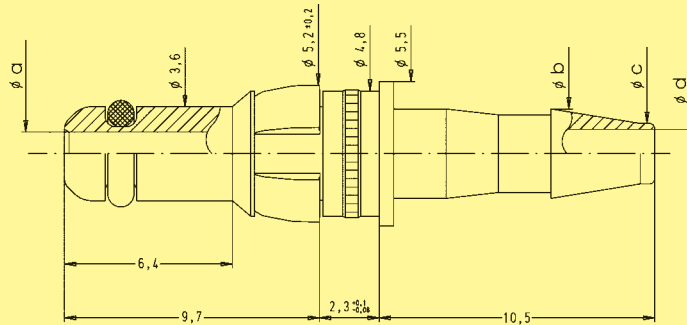

Part No.	ø a	ø b	ø c	ø d
09 69 x87 0061	1.45	2.6	1.5	0.95
09 69 x87 0060	1.65	3.1	2.0	1.65
09 69 x87 0062	1.65	3.4	2.3	1.85
09 69 x87 0063	1.65	4.8	3.7	2.95

Female contacts

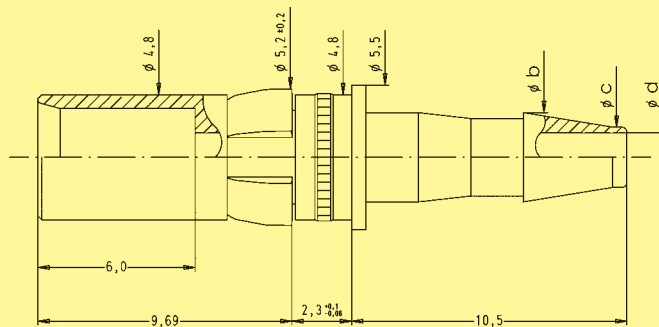

Dimensions in mm

Board drillings for connectors with straight pcb contacts

Pcb hole patterns

In the next pages, the pcb hole pattern is given for the power and the coaxial contact per connector layout. In the case of the power contact, the drilling hole dimension is not mentioned; the table here under provides relevant information according to the current rating of the contact and its version.

Power contact diameter and pcb related drilling diameter

Rating	Straight connectors		Right angled connectors	
	Pin Ø (mm)	Pcb drilling Ø (mm)	Pin Ø (mm)	Pcb drilling Ø (mm)
20 A	2.60	2.9	2.85	3.15
30 A	—	—	3.20	3.50
40 A	3.75	4.0	3.75	4.05

D-Sub - III

Identification Drawing Dimensions in mm

Male connector*

Power contact

Coaxial contact

2W2C

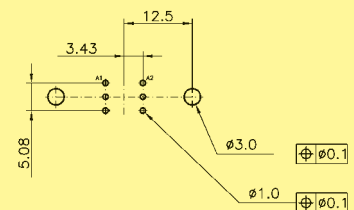
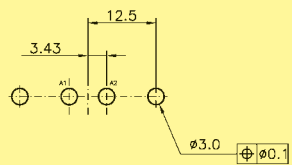

3W3 / 3W3C

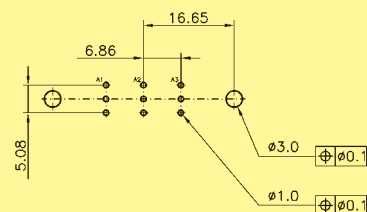
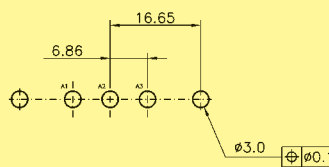

5W1

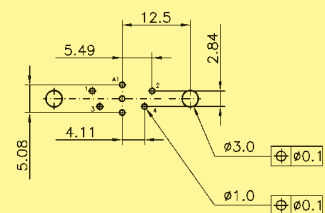
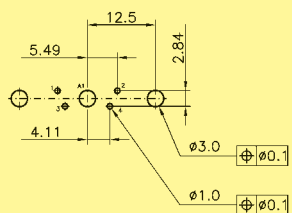

5W5

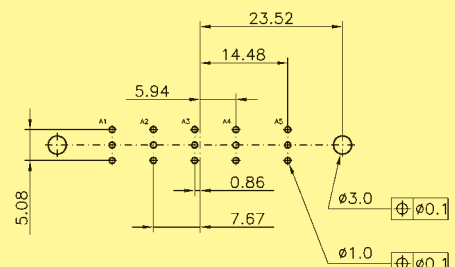
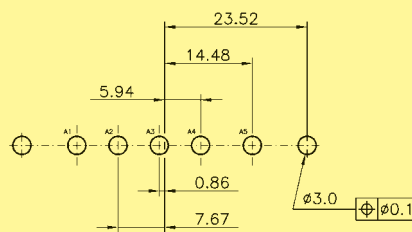

7W2

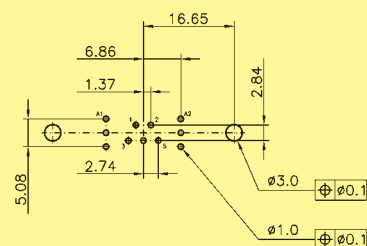
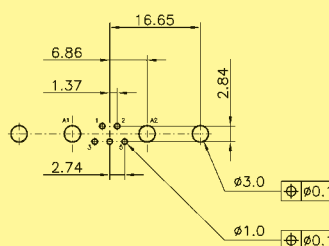

* When using a female connector with straight pcb contacts the board drilling pattern must be mirrored in the Y axis.



Board drillings for connectors with straight pcb contacts

Identification

Drawing

Dimensions in mm

Male connector*

Power contact

Coaxial contact

7W7

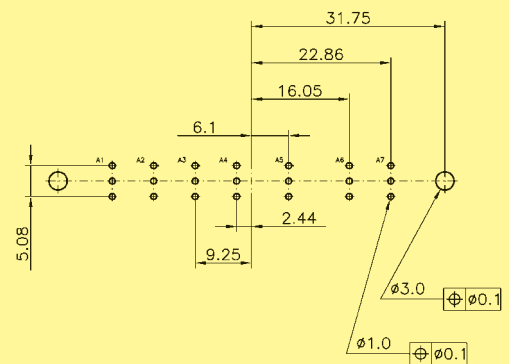
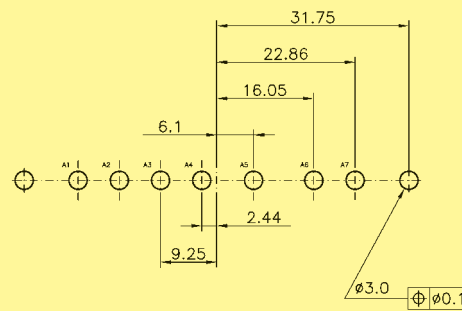

8W8

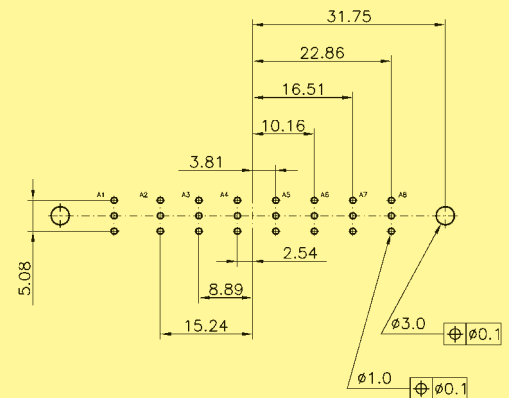
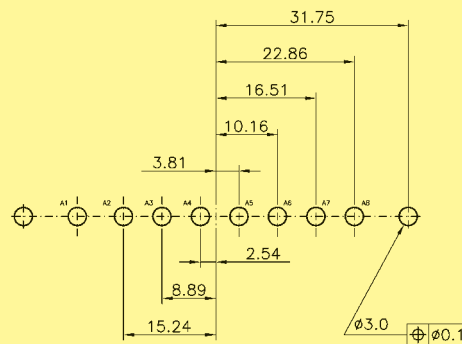

9W4

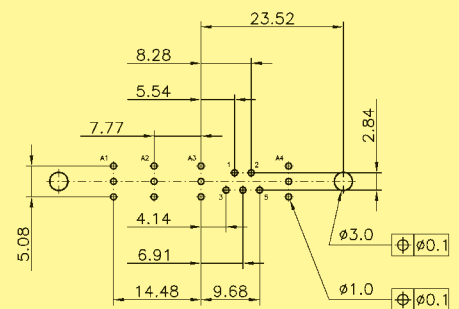
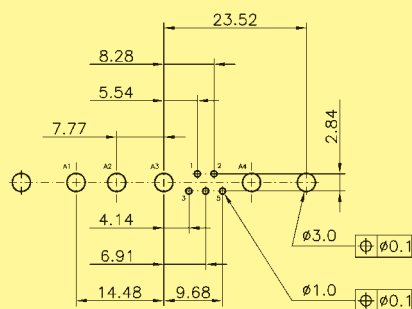

11W1

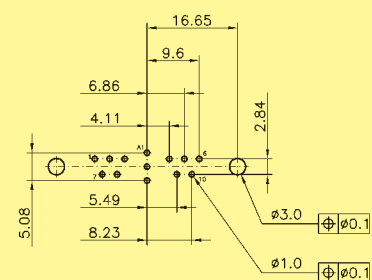
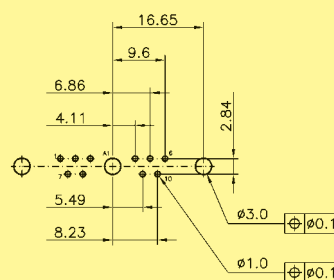

D-Sub - M

* When using a female connector with straight pcb contacts the board drilling pattern must be mirrored in the Y axis.



Board drillings for connectors with straight pcb contacts

Identification

Drawing

Dimensions in mm

Male connector*

13W3

Power contact

Coaxial contact

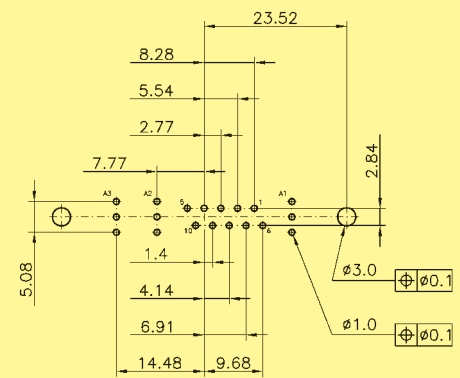
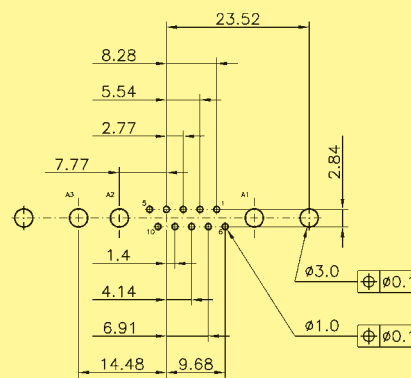

13W6

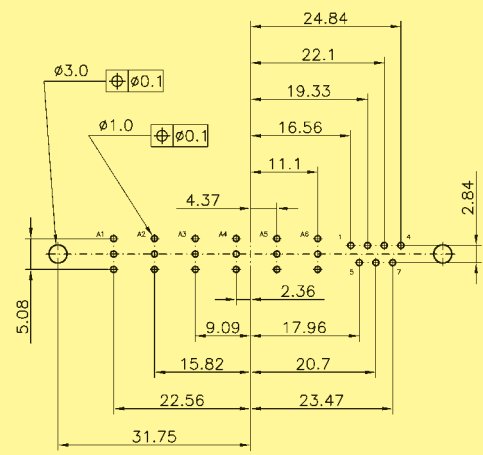
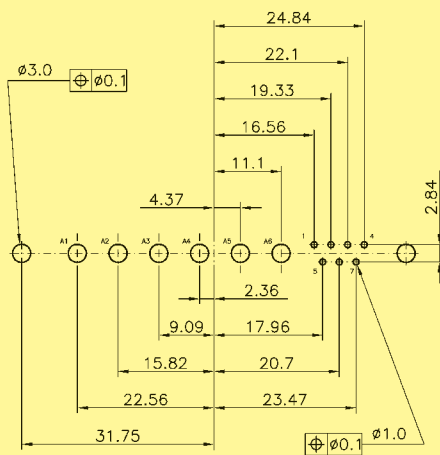

17W2

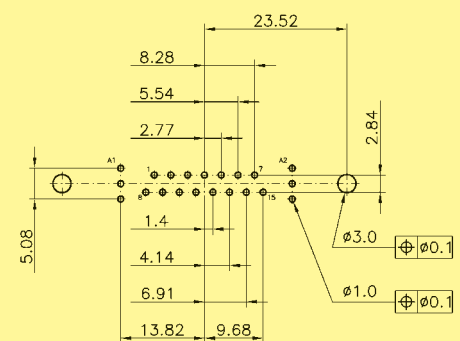
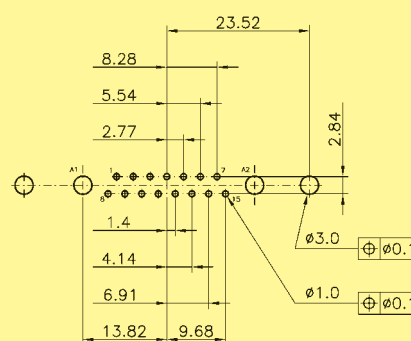

* When using a female connector with straight pcb contacts the board drilling pattern must be mirrored in the Y axis.



Board drillings for connectors with straight pcb contacts

Identification

Drawing

Dimensions in mm

Male connector*

21W1

Power contact

Coaxial contact

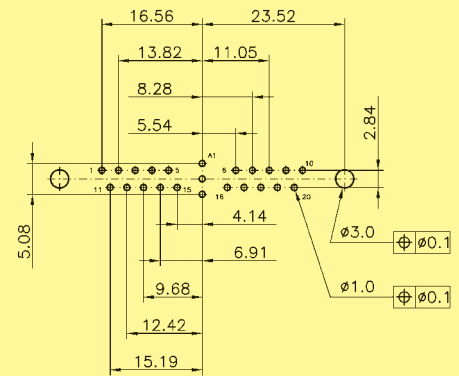
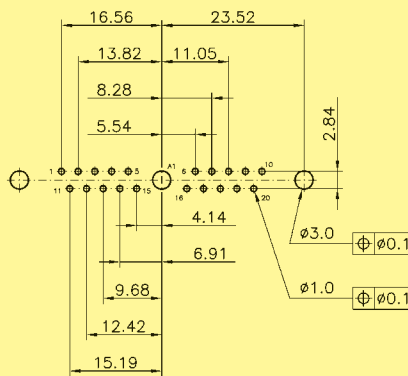

21WA4

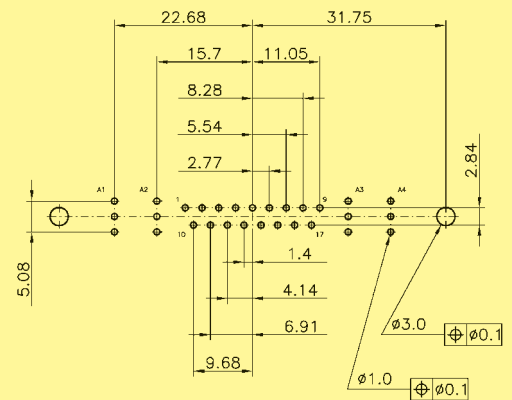
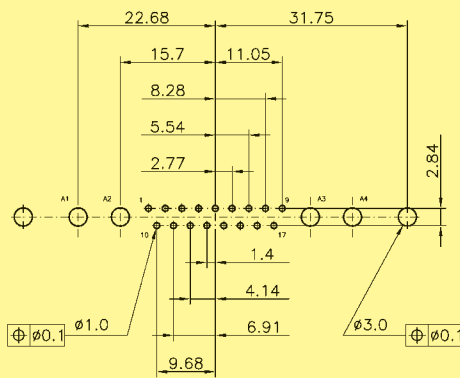

24W7

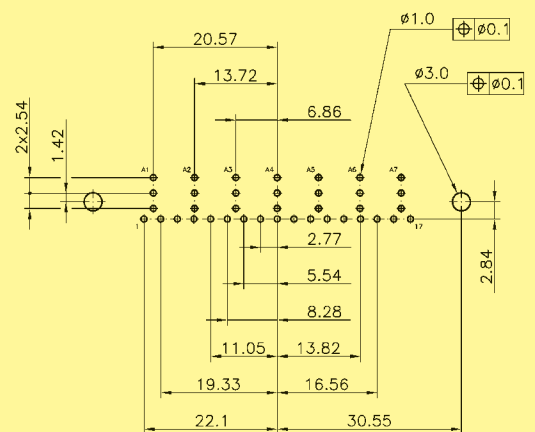
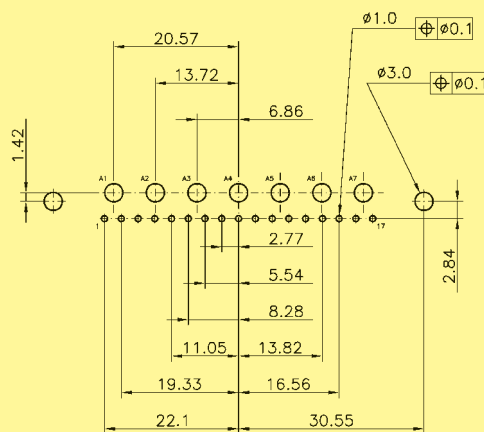

* When using a female connector with straight pcb contacts the board drilling pattern must be mirrored in the Y axis.



Board drillings for connectors with straight pcb contacts

Identification

Drawing

Dimensions in mm

Male connector*

25W3

Power contact

Coaxial contact

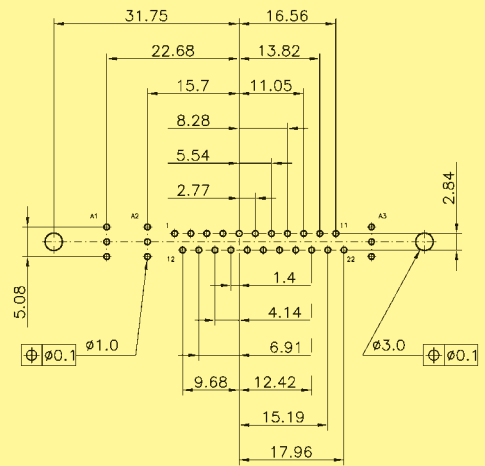
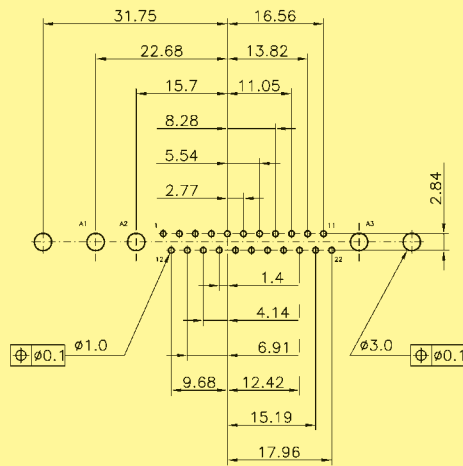

27W2

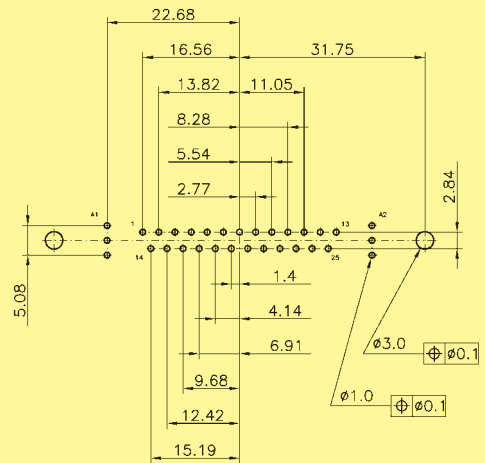
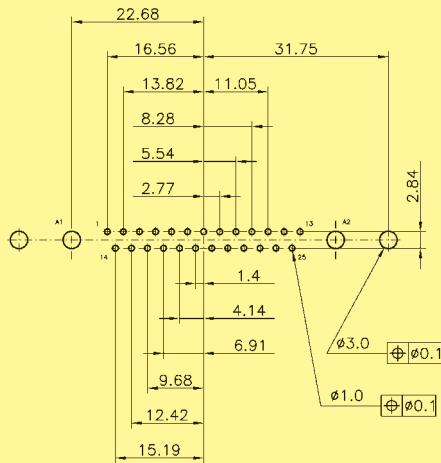

36W4

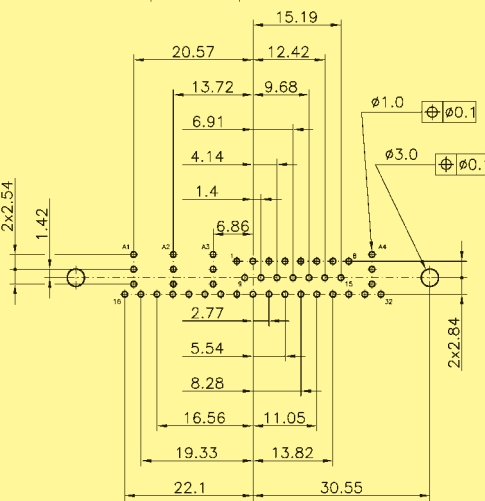
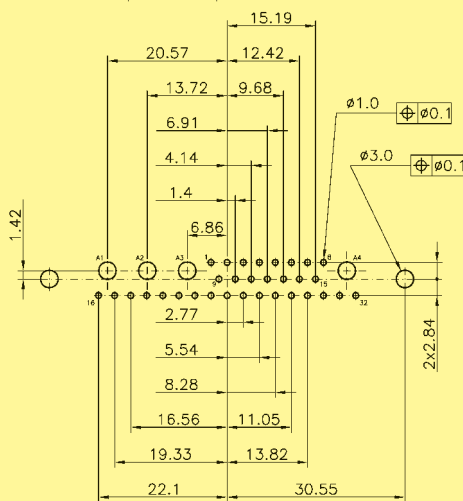

* When using a female connector with straight pcb contacts the board drilling pattern must be mirrored in the Y axis.



Board drillings for connectors with right angled pcb contacts

Identification Drawing Dimensions in mm

Male connector*

2W2C

Power contact

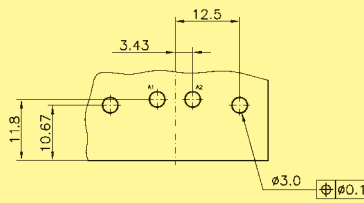

Coaxial contact

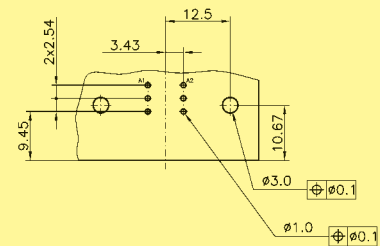

3W3 / 3W3C

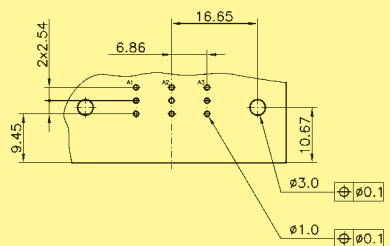
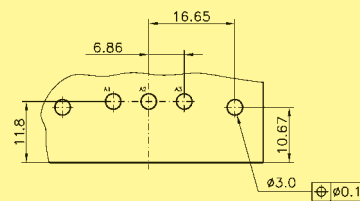

5W1

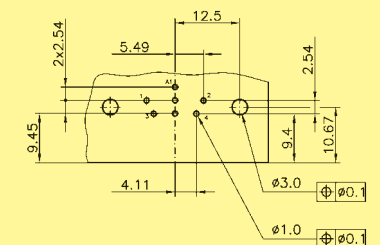
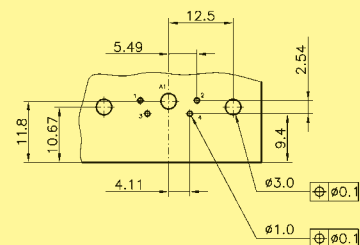

5W5

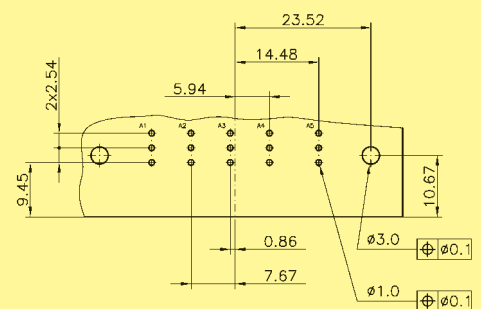
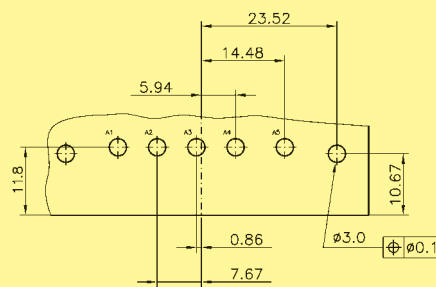

7W2

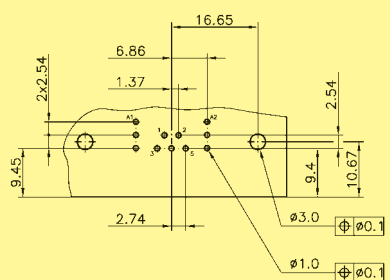
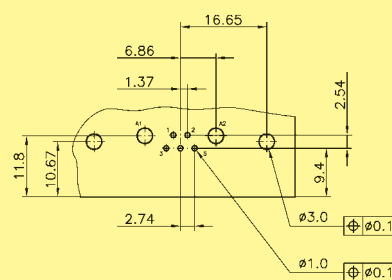

D-Sub - M

* When using a female connector with right angled pcb contacts the board drilling pattern must be mirrored in the Y axis.



Board drillings for connectors with right angled pcb contacts

Identification Drawing Dimensions in mm

Male connector*

7W7

Power contact

Coaxial contact

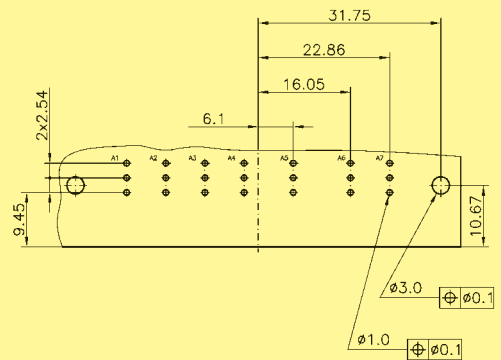
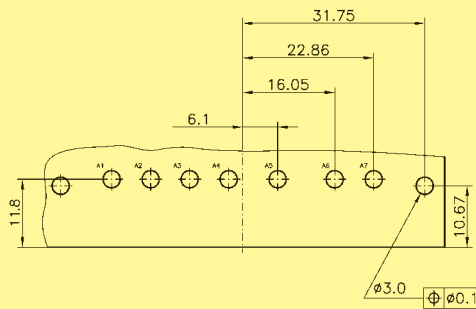

8W8

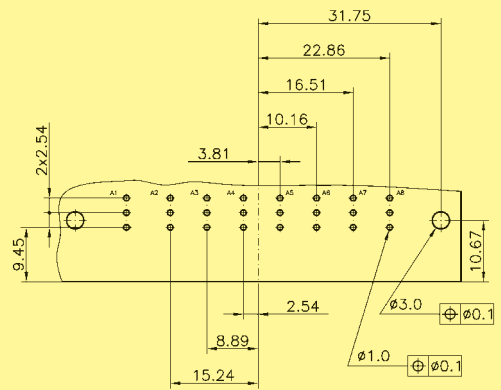
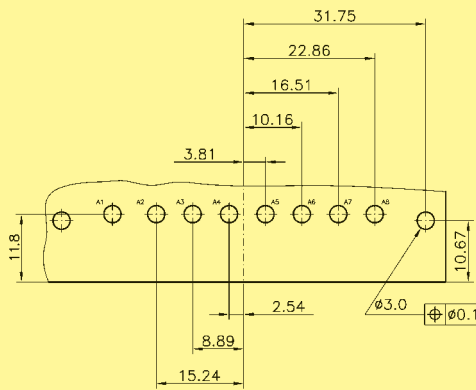

9W4

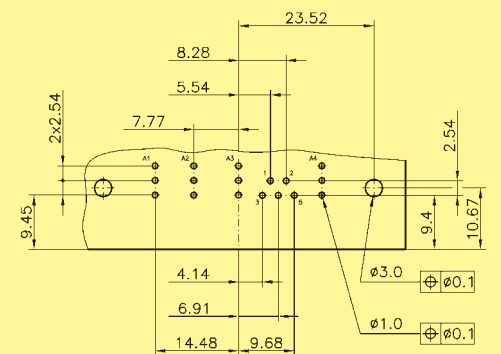
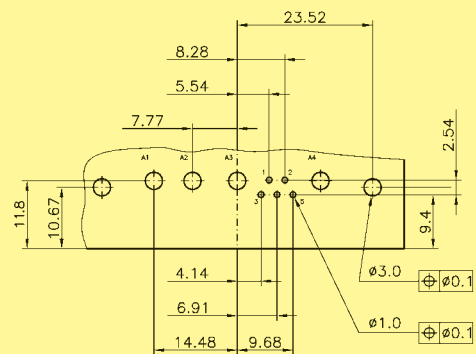

11W1

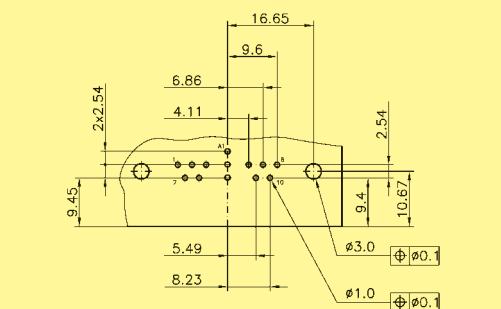
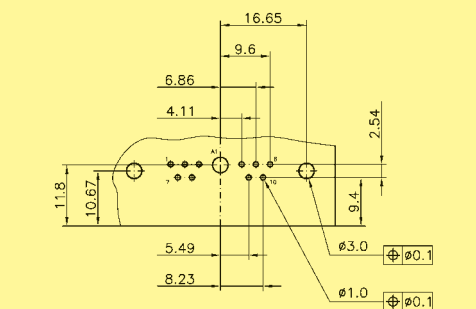

D-Sub - III

* When using a female connector with right angled pcb contacts the board drilling pattern must be mirrored in the Y axis.



Board drillings for connectors with right angled pcb contacts

Identification

Drawing

Dimensions in mm

Male connector*

13W3

Power contact

Coaxial contact

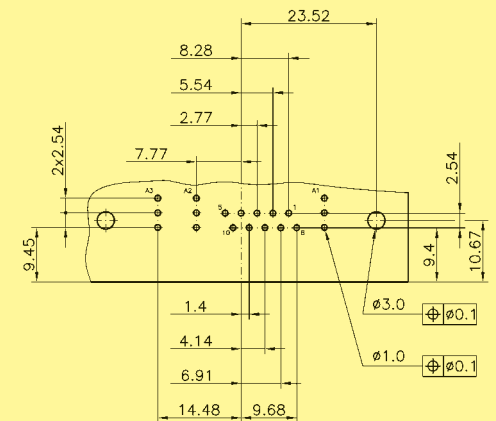
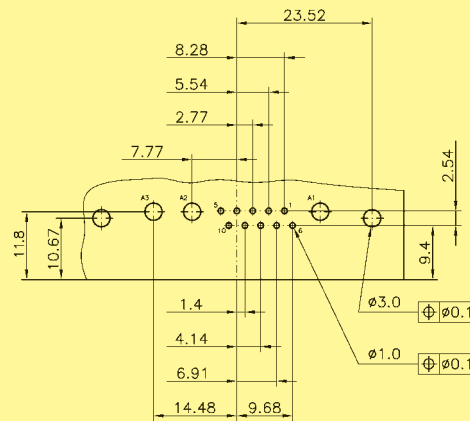

13W6

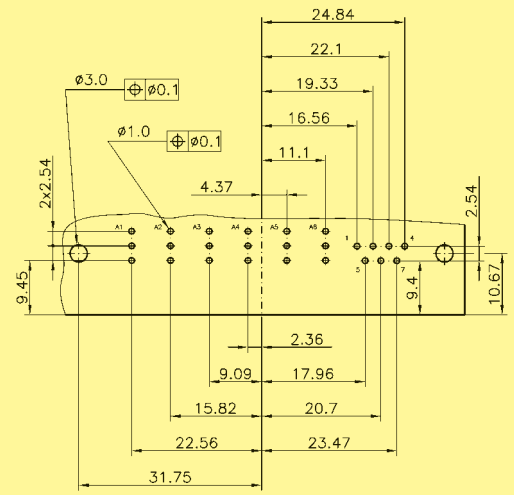
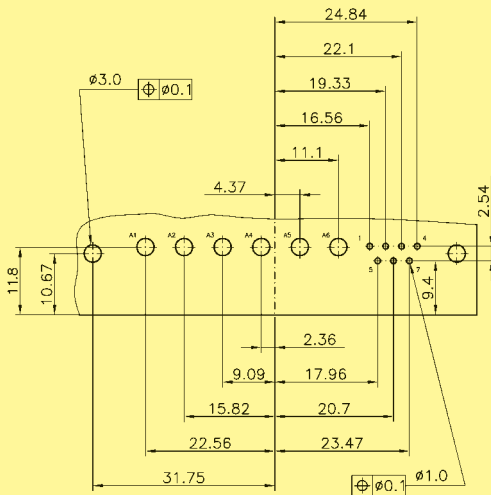

17W2

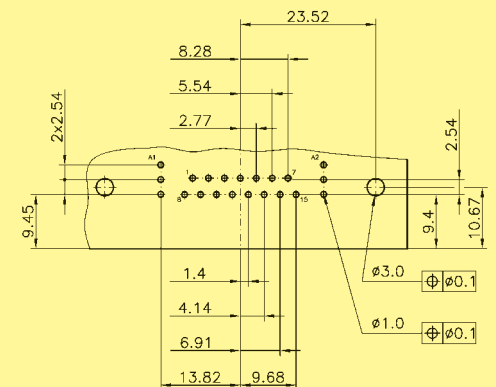
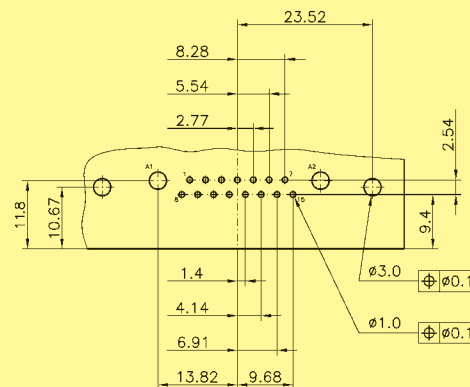

* When using a female connector with right angled pcb contacts the board drilling pattern must be mirrored in the Y axis.



Board drillings for connectors with right angled pcb contacts

Identification Drawing Dimensions in mm

Male connector*

21W1

Power contact

Coaxial contact

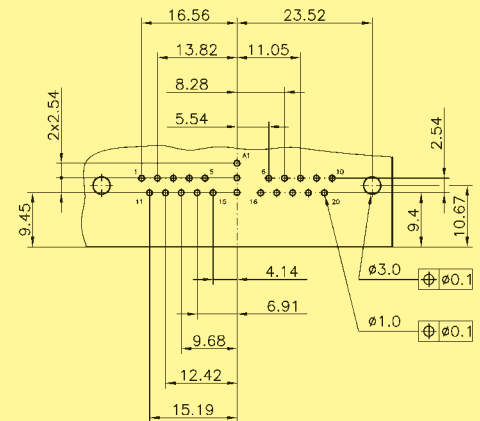
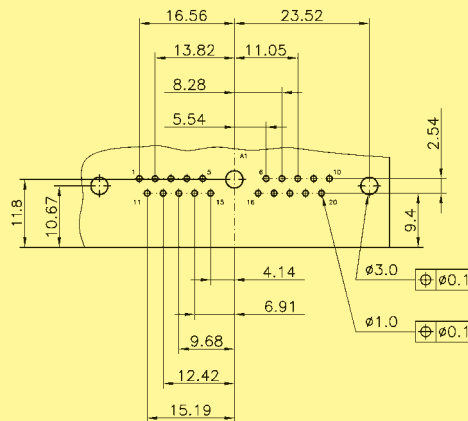

21WA4

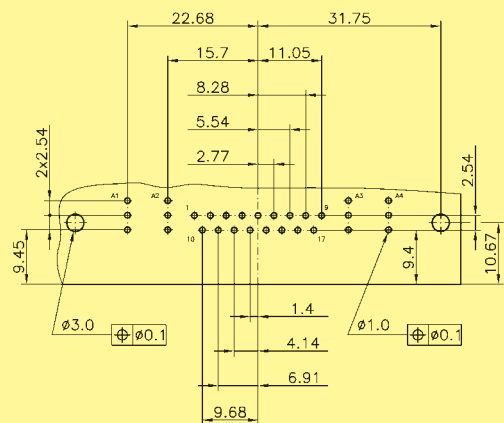
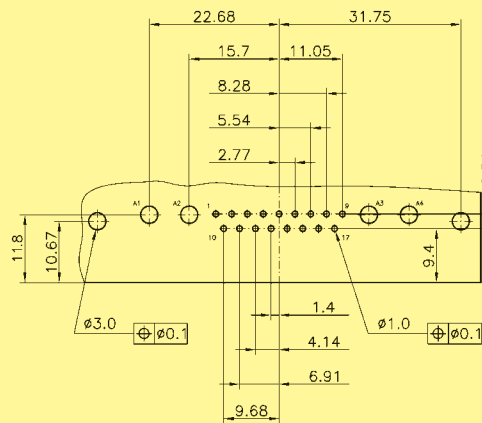

24W7

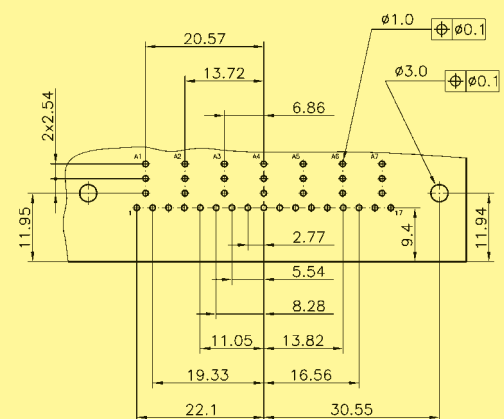
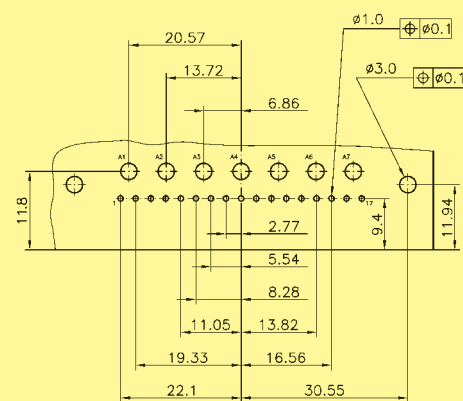

* When using a female connector with right angled pcb contacts the board drilling pattern must be mirrored in the Y axis.



Board drillings for connectors with right angled pcb contacts

Identification

Drawing

Dimensions in mm

Male connector*

25W3

Power contact

Coaxial contact

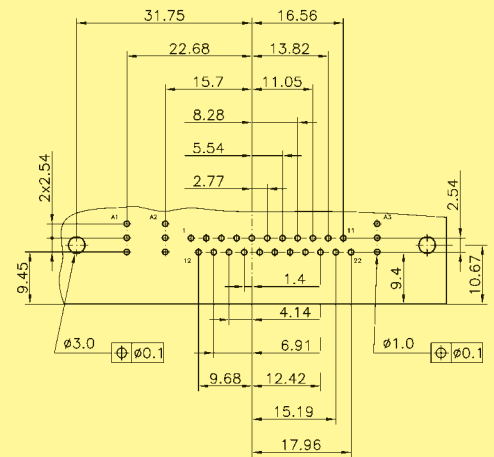
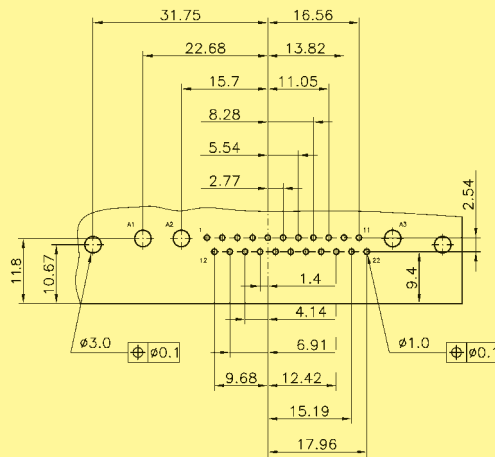

27W2

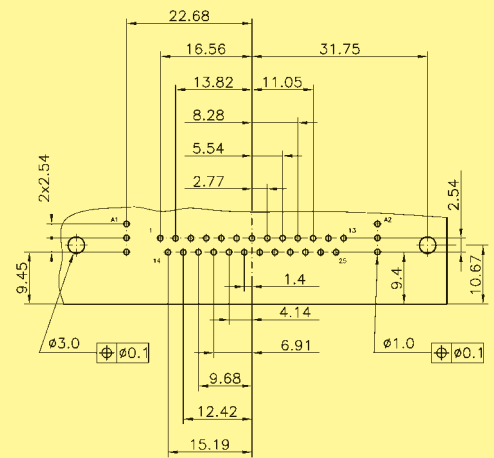
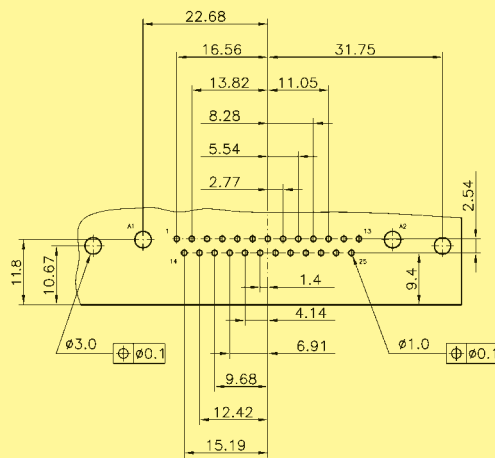

36W4

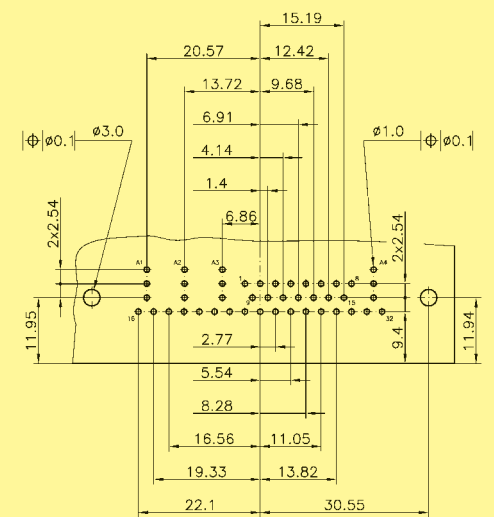
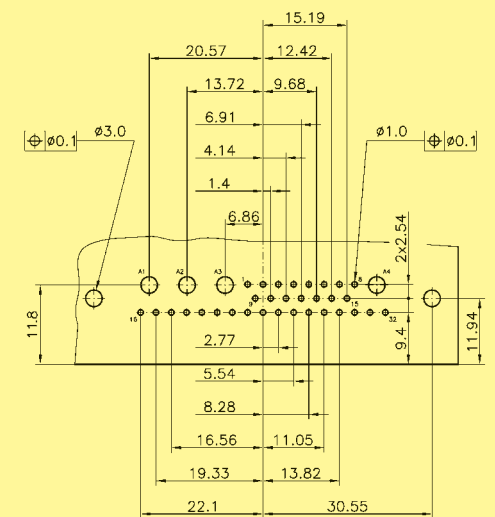

D-Sub - M

* When using a female connector with right angled pcb contacts the board drilling pattern must be mirrored in the Y axis.

HARTING customer request form for pcb connectors

1 Connector gender and type

- Plug (male contacts)
- Receptacle (female contacts)

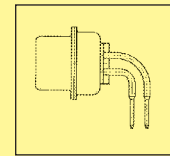
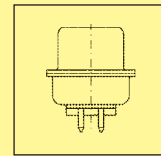

- Straight
- Right angled

2 Contact arrangement

Standard

- | | | | |
|------------------------------|-------------------------------|--------------------------------|-------------------------------|
| <input type="checkbox"/> 3W3 | <input type="checkbox"/> 8W8 | <input type="checkbox"/> 17W2 | |
| <input type="checkbox"/> 5W1 | <input type="checkbox"/> 9W4 | <input type="checkbox"/> 21W1 | |
| <input type="checkbox"/> 5W5 | <input type="checkbox"/> 11W1 | <input type="checkbox"/> 21WA4 | |
| <input type="checkbox"/> 7W2 | <input type="checkbox"/> 13W3 | <input type="checkbox"/> 24W7 | <input type="checkbox"/> 27W2 |
| <input type="checkbox"/> 7W7 | <input type="checkbox"/> 13W6 | <input type="checkbox"/> 25W3 | <input type="checkbox"/> 36W4 |

Special configurations
(mixed contact genders)

- 2W2C
- 3W3C

2.1 Any signal contacts?

- Yes (fill in questions below) No (go directly to item 2.2)
- Right angled 2.54 mm pitch
- Other pitch: _____

2.2 Any power contacts?

Current rating

- Yes (fill in questions below) No (go directly to item 2.3)
- 10 A 30 A
- 20 A 40 A

Termination type

- Solder pin for pcb
- Press-in for pcb (30A)

Performance level
[mating side / termination side]

- S4 [0.76 µm Au / 0.2 µm Au]
- PL 3 [0.2 µm Au / 5.0 µm Sn]

2.3 Any coaxial contacts?

Impedance

- Yes (fill in questions below) No (go directly to item 2.4)
- 50 Ω
- 75 Ω

Performance level
[mating side inner / outer conductor]

- S4 [1.3 µm Au / 0.76 µm Au]
- PL 3 [0.2 µm Au / 0.2 µm Au]

2.4 Any high voltage contacts?

- Yes No (go directly to item 2.5)

2.5 Any pneumatic contacts?

Tube inner diameter /
suitable compressed air tube

- Yes (fill in questions below) No (go directly to item 3)
- 2 mm / PU-2 2.6 mm / PU-N4* 2.5
- 3 mm / PU-3 4 mm / PU-4

HARTING customer request form for pcb connectors

3 Pcb mounting accessories (select appropriate fixing accessories)

3.1 Right angled version

- Through hole
 - Nut 4-40 UNC
 - Nut M3
 - Metal bracket
 - Snap clip
 - Screw lock
 - fixed removable
 - 4-40 UNC M3
-

3.2 Straight version

- Through hole
 - Nut 4-40 UNC
 - Nut M3
 - Spacer 4-40 UNC
 - Spacer M3
 - Screw lock 4-40 UNC
 - Spacer 4-40 UNC + clip
 - Spacer M3 + clip
 - Spacer + clip and screw lock
 - M3 4-40 UNC
-

4 Additional information

Pcb thickness:

(if possible provide pcb layout with plating specifications)

Operating temperature:

- standard
- SMC compatible

Is hot plugging required

- No
- Yes

Short description: _____

Is a vacuum pick and place process considered?

- No
- Yes

Is blind mating feature required?

- No
- Yes (provide precise requirements)

Name: _____

Drawing: no yes

Company: _____

Samples: no yes, quantity

Address: _____

Volume (pcs./year): _____

Phone: _____

Special requirements: _____

Fax: _____

E-Mail: _____

HARTING customer request form for cable connectors

1 Connector gender

- Plug (male contacts)
 Receptacle (female contacts)



21W4 mixed male for cable

2 Contact arrangement

Standard

- | | | | |
|------------------------------|-------------------------------|--------------------------------|-------------------------------|
| <input type="checkbox"/> 3W3 | <input type="checkbox"/> 8W8 | <input type="checkbox"/> 17W2 | |
| <input type="checkbox"/> 5W1 | <input type="checkbox"/> 9W4 | <input type="checkbox"/> 21W1 | |
| <input type="checkbox"/> 5W5 | <input type="checkbox"/> 11W1 | <input type="checkbox"/> 21WA4 | |
| <input type="checkbox"/> 7W2 | <input type="checkbox"/> 13W3 | <input type="checkbox"/> 24W7 | <input type="checkbox"/> 27W2 |
| <input type="checkbox"/> 7W7 | <input type="checkbox"/> 13W6 | <input type="checkbox"/> 25W3 | <input type="checkbox"/> 36W4 |

Special configurations
(mixed contact genders)

- 2W2C 3W3C

2.1 Any signal contacts?

- Yes (fill in questions below) No (go directly to item 2.2)

Termination type

- Crimp Solder cup S4 [0.76 µm Au]

Signal cable size for crimp contact

- AWG 20-24 AWG 26-28

Crimp contact performance level

- S4 [0.76 µm Au / 0.2 µm Au]
 PL3 [0.2 µm Au / 5.0 µm Sn]

2.2 Any power contacts?

- Yes (fill in questions below) No (go directly to item 2.3)

Current rating

- 10 A 20 A 30 A 40 A

Termination type

- Crimp Solder cup

Performance level

[mating side / termination side]

- S4 [0.76 µm Au / 0.2 µm Au]
 PL3 [0.2 µm Au / 5.0 µm Sn]

2.3 Any coaxial contacts?

- Yes (fill in questions below) No (go directly to item 2.4)

Impedance

- 50 Ω 75 Ω

Termination type

- Crimp/crimp
 Crimp/solder [inner conductor is soldered, outer crimped]

Performance level

[mating side inner / outer conductor]

- S4 [1.3 µm Au / 0.76 µm Au]
 PL3 [0.2 µm Au / 0.2 µm Au]

Cable reference (e.g. RG 178): _____

HARTING customer request form for cable connectors

2.4 Any high voltage contacts? Yes No (go directly to item 2.5)

2.5 Any pneumatic contacts? Yes (fill in questions below) No (go directly to item 3)

Tube inner diameter /

suitable compressed air tube

2 mm / PU-2

3 mm / PU-3

2.6 mm / PU-N4* 2.5

4 mm / PU-4

3 Cable accessories

HARTING has a wide range of hoods including plastic, metallized plastic and full metal versions.

Name: _____

Drawing: no yes _____

Company: _____

Samples: no yes, quantity _____

Address: _____

Volume (pcs./year): _____

Phone: _____

Special requirements: _____

Fax: _____

E-Mail: _____
