

Datasheet

The DXM700-B1 Wireless Controller is an industrial wireless controller that facilitates Industrial Internet of Things (IIoT) applications. As a communications gateway, it interfaces local serial ports, local I/O ports, and local ISM radio devices to the Internet using a cellular connection or wired Ethernet network connection.

- **High Performance Wireless Communication**—Uses Sure Cross® DX80 Wireless Gateway or MultiHop radio with 900 MHz or 2.4 GHz ISM bands available for long range communication
- **Flexible and Customizable**—Expanded internal logic controller with action rules and ScriptBasic programming capable of developing simple or complex solutions to process, log, and control data to/from multiple wireless radios and sensors
- **Improved Speed and Memory**—Upgraded internal processor to use 2850 32-bit integer registers, 2000 floating-point registers, and 1050 non-volatile 32-bit integer registers; expanded ScriptBasic programming capability for faster script processing and ability to build more complex solutions with scripts



- **External Communications**—Cellular modem Internet connectivity
- **Compact Size**—Reduced size of 70 mm to consume less space on a DIN rail
- **Simple Sourcing Outputs**—Four PNP outputs (100 mA max at 30 V dc) available for local triggers
- **Industry Compatibility**—Automation protocols include Modbus/TCP, Modbus RTU, and EtherNet/IP™ for communications between PLCs, HMIs, or other local hosts.
- **Customizable Alerts**—Secure email for alarms and alerts
- Data logged to a removable SD card or sent via email
- Interactive programmable user interface with LCD and LED indicators
- Industry standard RS-485, Ethernet, and USB communication ports



WARNING:

- **Do not use this device for personnel protection**
- Using this device for personnel protection could result in serious injury or death.
- This device does not include the self-checking redundant circuitry necessary to allow its use in personnel safety applications. A device failure or malfunction can cause either an energized (on) or de-energized (off) output condition.



Important:

- **Never operate a 1 Watt radio without connecting an antenna**
- Operating 1 Watt radios without an antenna connected will damage the radio circuitry.
- To avoid damaging the radio circuitry, never apply power to a Sure Cross® Performance or Sure Cross MultiHop (1 Watt) radio without an antenna connected.



Important:

- **Electrostatic discharge (ESD) sensitive device**
- ESD can damage the device. Damage from inappropriate handling is not covered by warranty.
- Use proper handling procedures to prevent ESD damage. Proper handling procedures include leaving devices in their anti-static packaging until ready for use; wearing anti-static wrist straps; and assembling units on a grounded, static-dissipative surface.

Model Key for the DXM700-B1 Models

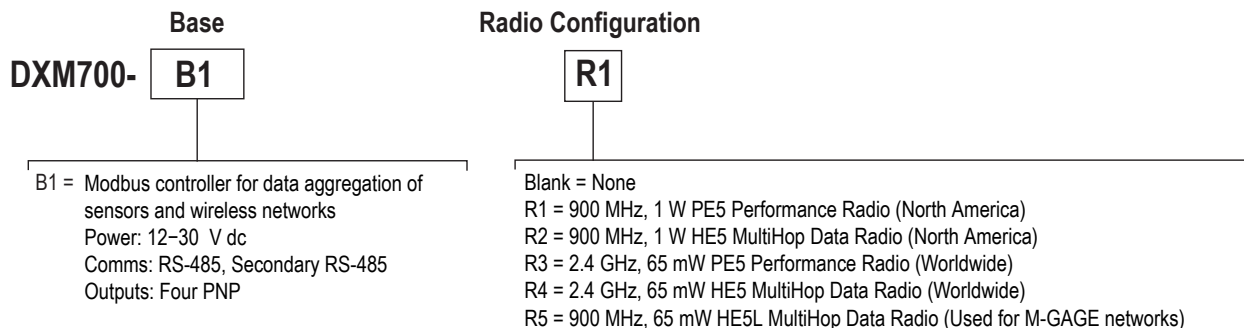

Some example models include, but are not limited to, the following:

Models	Description
DXM700-B1R1	DXM700-B1 Wireless Controller with DX80 ISM 900 MHz radio
DXM700-B1R2	DXM700-B1 Wireless Controller with DX80 ISM 900 MHz MultiHop radio
DXM700-B1R3	DXM700-B1 Wireless Controller with DX80 ISM 2.4 GHz radio
DXM700-B1R4	DXM700-B1 Wireless Controller with DX80 ISM 2.4 GHz MultiHop radio
DXM700-B1R5	DXM700-B1 Wireless Controller with DX80 ISM 900 MHz MultiHop 100mW radio

Cellular Communication— Controllers accept Banner LTE (United States) and GSM (outside the United States) modems only. Cellular modems are ordered separately as accessories under the following part numbers:

- LTE-Verizon (United States only): **SXI-LTE-001**
- GSM/3G (HSPA) (International only): **SXI-GSM-001**

DXM700 Documentation

For more information about the DXM700-B1 family of products, please see additional documentation and videos on the Banner website: www.bannerengineering.com.

- DXM Wireless Controller Sell Sheet, p/n [194063](#)
- DXM700-B1 Wireless Controller Datasheet, p/n [207893](#)
- DXM700-Bx Wireless Controller Instruction Manual, p/n [207894](#)
- DXM ScriptBasic Instruction Manual, p/n [191745](#)
- DXM Controller Configuration Quick Start, p/n [191247](#)
- DXM Configuration Tool software (p/n [b_4447978](#))
- DXM Configuration Tool Instruction Manual, p/n [158447](#)
- DXM EDS [Configuration file](#) for Allen-Bradley PLCs
- EIP Configuration File for DXM 1xx-BxR1 and R3 models (p/n [194730](#))
- Activating a Cellular Modem (p/n [b_4419353](#))
- Additional technical notes and videos

Technical notes, configuration examples, and ScriptBasic program examples are available at www.bannerengineering.com.

DXM700-Bx System Overview

Banner's DXM Logic Controller integrates Banner's wireless radio, cellular connectivity, and local I/O to provide a platform for the Industrial Internet of Things (IIoT).

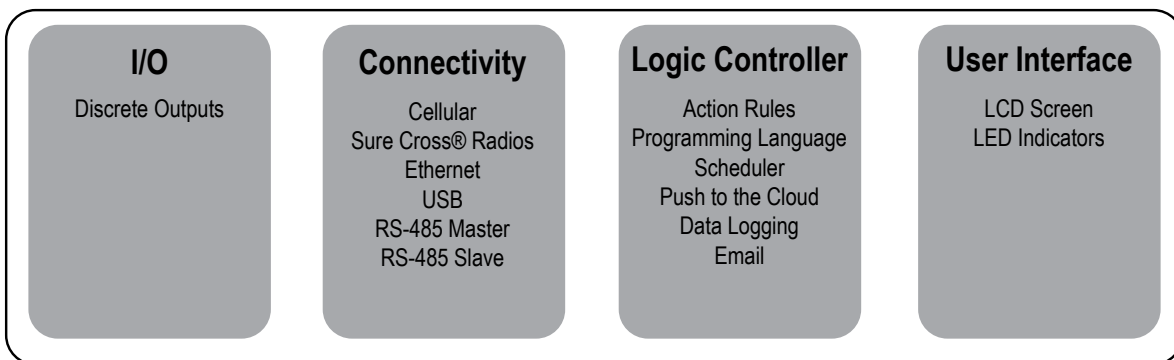

Figure 1. DXM700-B1 system overview

Modbus Registers for Internal Local Registers (Modbus Slave ID 199)		
Local Registers	Type	Description
1–845	32-bit integer	Local data registers
846–849	32-bit integer	Reset, Constant, Timer
851–900	32-bit non-volatile integer	Data flash, non-volatile
901–1000		Reserved for internal use
1001–5000	Floating point	Floating point registers, local data registers

Modbus Registers for Internal Local Registers (Modbus Slave ID 199)		
Local Registers	Type	Description
5001–7000	32-bit integer	Same as 1–845
7001–8000	32-bit non-volatile integer	Same as 851–900
> 10000		Read only virtual registers, system-level data

Outputs—Four discrete PNP outputs (supply voltage minus 2 V, 100mA maximum at 30 V dc)

Connectivity—The DXM700-B1's wired and wireless connectivity options make it easy to share data between local and remote equipment. The cellular modem option eliminates the need for IT infrastructures to connect remote equipment for sensing and control to IIoT cloud services. The integrated Sure Cross® wireless radio enables Modbus connectivity to remote sensors, indicators, and control equipment.

Wired Connectivity

- Ethernet: Modbus/TCP (master/slave) or Ethernet/IP
- Field Bus: Modbus RS-485 Master/Slave

Wireless Connectivity

- Sure Cross Wireless Radio: DX80 900 MHz, DX80 2.4 GHz, MultiHop 900 MHz, or MultiHop 2.4 GHz
- Cellular modem: LTE (United States only) or GSM (Outside the United States)

Logic Controller—Program the DXM700-B1's logic controller using action rules and/or ScriptBasic language, which can execute concurrently. The control functions allow freedom when creating custom sensing and control sequences. The logic controller supports the Modbus protocol standards for data management, ensuring seamless integration with existing automation systems. File and LCD password protection is an option.

Register Mapping

- Cyclical Read rules from wireless devices or local wired Modbus devices that include optional scaling, error conditions, and the ability to activate a read rule
- Cyclical or Change of State Write rules to wireless devices or local wired Modbus devices with scaling
- Modbus/TCP Master Read or Write rules for external devices on the network

Action Rules

- Thresholds (IF/THEN/ELSE) with timers, minimum on/off time, and logging options
- Math/Logic Rules (arithmetic and bitwise operators)
- Control Logic (logical operators and SR/T/D/JK flip flops)
- Trending (multiple averaging filters)
- Tracking (counts, on/off times)
- Email notifications
- Push data on conditions

Scheduler

- Time/calendar-based events
- Holiday skips
- One-time events
- Dynamic scheduler updating
- Astronomical clock

Optional Text Programming Language

- ScriptBasic to create variables, arrays, functions, loops, IF/THEN/ELSE, logical and arithmetic operators, API commands, register access, string functions and operators, time commands

Data Logging

- Cyclic data/event logging
- Email log files

User Interface— A simple user interface consists of an LCD screen and four LED indicators.

User programmable LCD

- Bind Sure Cross radios
- Conduct a site survey to evaluate the radio signal integrity of radios within the network
- View register and output information
- View system status and configuration

API Interface

- Host Initiated control
- Web service integration

User Defined LED indicators

- Indicates the status of the DXM700-B1, processes, or equipment

Applications Overview

The DXM700-B1 is ideal for smart factory and facilities applications, including:

- Productivity solutions, such as
 - Call for parts, service, or maintenance
 - Pick-to-light
 - OEE Tower light monitoring
- Predictive maintenance and continuous monitoring using
 - Vibration and temperature monitoring

- Tank level monitoring
- Non-contact condition monitoring
- Environmental monitoring and control, such as
 - Temperature and humidity monitoring

The DXM700-B1 can provide visual indication using indicator lights, send email alerts, collect data, and interface with automation systems.

Specifications

MultiHop Radio Specifications

Radio Range¹

900 MHz, 1 Watt: Up to 9.6 km (6 miles)
2.4 GHz, 65 mW: Up to 3.2 km (2 miles)

Antenna Minimum Separation Distance

900 MHz, 150 mW and 250 mW: 2 m (6 ft)
900 MHz, 1 Watt: 4.57 m (15 ft)
2.4 GHz, 65 mW: 0.3 m (1 ft)

Radio Transmit Power

900 MHz, 1 Watt: 30 dBm (1 W) conducted (up to 36 dBm EIRP)
2.4 GHz, 65 mW: 18 dBm (65 mW) conducted, less than or equal to 20 dBm (100 mW) EIRP

Spread Spectrum Technology

FHSS (Frequency Hopping Spread Spectrum)

900 MHz Compliance (1 Watt)

FCC ID UE3RM1809: FCC Part 15, Subpart C, 15.247
IC: 7044A-RM1809

2.4 GHz Compliance (MultiHop)

FCC ID UE300DX80-2400: FCC Part 15, Subpart C, 15.247
RED Directive 2014/53/EU
IC: 7044A-DX8024

Antenna Connection

Ext. Reverse Polarity SMA, 50 Ohms
Max Tightening Torque: 0.45 N-m (4 lbf-in)

Radio Packet Size (MultiHop)

900 MHz: 175 bytes (85 Modbus registers)
2.4 GHz: 75 bytes (37 Modbus registers)

RS-485 Communication Specifications

Communication Hardware (MultiHop RS-485)

Interface: 2-wire half-duplex RS-485
Baud rates: 9.6k, 19.2k (default), or 38.4k via DIP switches; 1200 and 2400 via the MultiHop Configuration Tool
Data format: 8 data bits, no parity, 1 stop bit

Power and I/O Specifications

Supply Voltage

12 to 30 V dc (use only with a suitable Class 2 power supply (UL) or a SELV (CE) power supply)

Power Consumption

35 mA average at 12 Volts

Communication Protocols

Modbus RTU Master/Slave, Modbus/TCP, and Ethernet/IP

Construction

Polycarbonate; DIN rail mount option

Security Protocols

VPN, SSL, and HTTPS

Logging

8 GB maximum; removable Micro SD card format

Discrete Outputs

Four, PNP/Sourcing
Update Rate: 125 milliseconds
ON Condition: Supply minus 2 V
OFF Condition: Less than 2 V

Discrete Output Rating (PNP)

100 mA max current at 30 V dc
ON-State Saturation: Less than 3 V at 100 mA
OFF-state Leakage: Less than 10 μ A

Environmental Specifications

Operating Conditions²

-40 °C to +85 °C (-40 °F to +185 °F) (Electronics); -20 °C to +80 °C (-4 °F to +176 °F) (LCD)
Micro SD Card (if applicable): -25 °C to +85 °C (-13 °F to +185 °F)
95% maximum relative humidity (non-condensing)
Radiated Immunity: 10 V/m (EN 61000-4-3)

Shock and Vibration

IEC 68-2-6 and IEC 68-2-27
Shock: 30g, 11 millisecond half sine wave, 18 shocks
Vibration: 0.5 mm p-p, 10 to 60 Hz

Environmental Rating

IEC IP20

Certifications



CE approval (pending)
only applies to 2.4 GHz models

¹ Radio range is with the 2 dB antenna that ships with the product. High-gain antennas are available, but the range depends on the environment and line of sight. Always verify your wireless network's range by performing a Site Survey.

² Operating the devices at the maximum operating conditions for extended periods can shorten the life of the device.

Dimensions

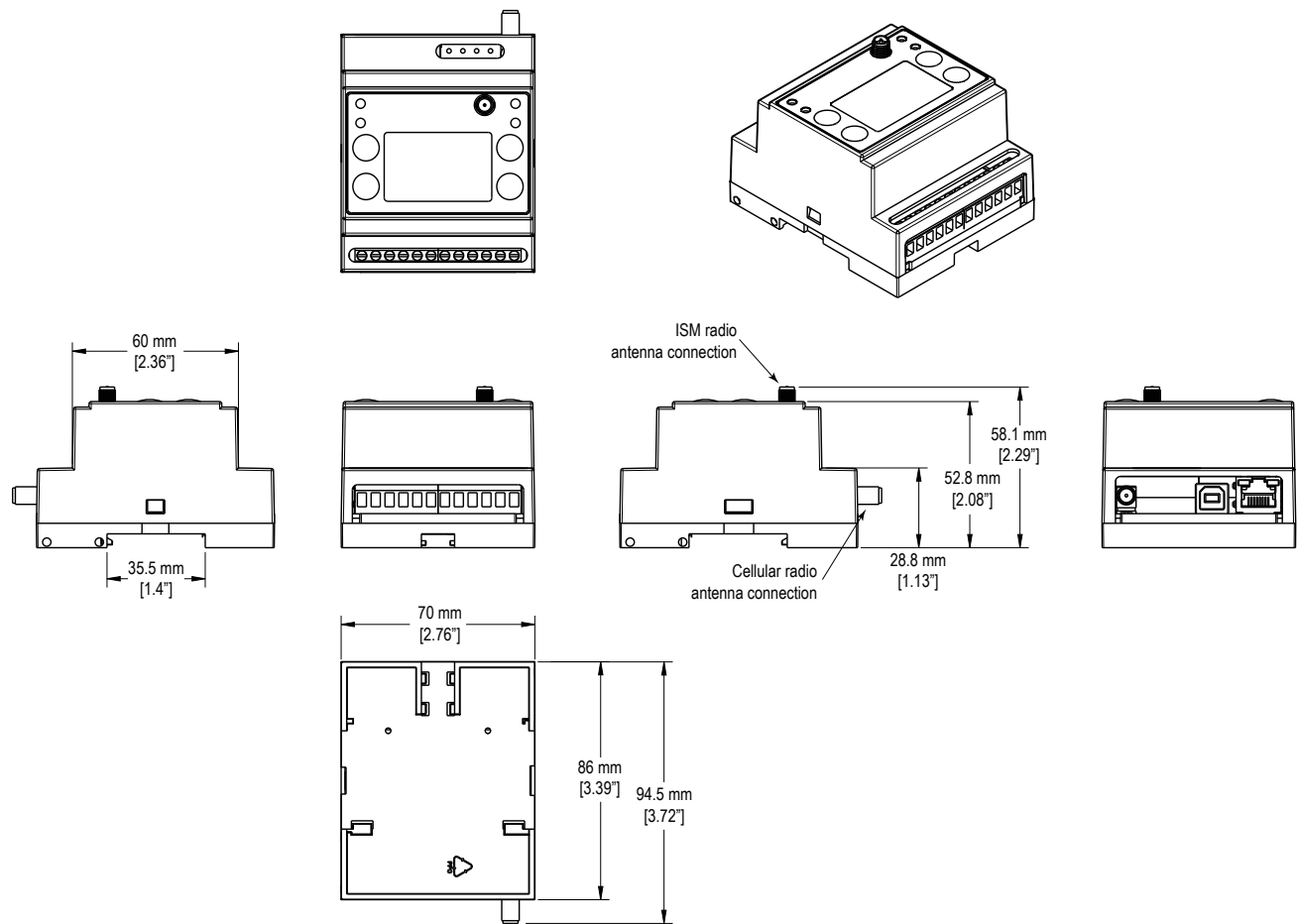

All measurements are listed in millimeters [inches], unless noted otherwise.

Accessories

For a complete list of all the accessories for the Sure Cross wireless product line, please download the [Accessories List](#) (p/n b_3147091).

Cordsets

- MQDC1-506—5-pin M12/Euro-style, straight, single ended, 6 ft
- MQDC1-530—5-pin M12/Euro-style, straight, single ended, 30 ft
- MQDC1-506RA—5-pin M12/Euro-style, right-angle, single ended, 6 ft
- MQDC1-530RA—5-pin M12/Euro-style, right-angle, single ended, 30 ft

Static and Surge Suppressor

- BWC-LFNBMN-DC—Surge Suppressor, bulkhead, N-Type, dc Blocking, N-Type Female, N-Type Male

Short-Range Omni Antennas

- BWA-2O2-D—Antenna, Dome, 2.4 GHz, 2 dBi, RP-SMA Box Mount
- BWA-9O2-D—Antenna, Dome, 900 MHz, 2 dBi, RP-SMA Box Mount
- BWA-9O2-RA—Antenna, Rubber Fixed Right Angle, 900 MHz, 2 dBi, RP-SMA Male Connector

Medium-Range Omni Antennas

- BWA-9O5-C—Antenna, Rubber Swivel, 900 MHz 5 dBi, RP-SMA Male Connector
- BWA-2O5-C—Antenna, Rubber Swivel, 2.4 GHz 5 dBi, RP-SMA Male Connector

Misc Accessories

- BWA-CG.5-3X5.6-10—Cable Gland Pack: 1/2-inch NPT, Cordgrip for 3 holes of 2.8 to 5.6 mm diam, qty 10
- BWA-HW-052—Cable Gland and Vent Plug Pack: includes 1/2-inch NPT gland, 1/2-inch NPT multi-cable gland, and 1/2-inch NPT vent plug, qty 1 each

Antenna Cables

- BWC-1MRSMN05—LMR100 RP-SMA to N-Type Male, 0.5 m
- BWC-2MRSFRS6—LMR200, RP-SMA Male to RP-SMA Female Bulkhead, 6 m
- BWC-4MNFN6—LMR400 N-Type Male to N-Type Female, 6 m

Long-Range Omni Antennas

- BWA-9O8-AS—Antenna, Fiberglass, 3/4 Wave, 900 MHz, 8 dBi, N-Type Female Connector
- BWA-2O8-A—Antenna, Fiberglass, 2.4 GHz, 8 dBi, N-Type Female Connector

Long-Range Yagi Antennas

- BWA-9Y10-A—Antenna, 900 MHz, 10 dBd, N-Type Female Connector

Enclosures and DIN Rail Kits

BWA-AH864—Enclosure, Polycarbonate, with Opaque Cover, 8 × 6 × 4
BWA-AH1084—Enclosure, Polycarbonate, with Opaque Cover, 10 × 8 × 4
BWA-AH12106—Enclosure, Polycarbonate, with Opaque Cover, 12 × 10 × 6
 BWA-AH8DR—DIN Rail Kit, 8", 2 trilobular/self-threading screws
 BWA-AH10DR—DIN Rail Kit, 10", 2 trilobular/self-threading screws
 BWA-AH12DR—DIN Rail Kit, 12", 2 trilobular/self-threading screws

Power Supplies

PSD-24-4—DC Power Supply, Desktop style, 3.9 A, 24 V dc, Class 2, 4-pin M12/Euro-style quick disconnect (QD)
PSDINP-24-06—DC Power Supply, 0.63 Amps, 24 V dc, with DIN Rail Mount, Class I Division 2 (Groups A, B, C, D) Rated
PSDINP-24-13—DC Power Supply, 1.3 Amps, 24 V dc, with DIN Rail Mount, Class I Division 2 (Groups A, B, C, D) Rated
PSDINP-24-25—DC Power Supply, 2.5 Amps, 24 V dc, with DIN Rail Mount, Class I Division 2 (Groups A, B, C, D) Rated
 PSW-24-1—DC Power Supply, 100-240 V ac 50/60 Hz input, 24 V dc 1 A output, UL Listed Class 2

Warnings

Install and properly ground a qualified surge suppressor when installing a remote antenna system. Remote antenna configurations installed without surge suppressors invalidate the manufacturer's warranty. Keep the ground wire as short as possible and make all ground connections to a single-point ground system to ensure no ground loops are created. No surge suppressor can absorb all lightning strikes; do not touch the Sure Cross® device or any equipment connected to the Sure Cross device during a thunderstorm.

Exporting Sure Cross® Radios. It is our intent to fully comply with all national and regional regulations regarding radio frequency emissions. **Customers who want to re-export this product to a country other than that to which it was sold must ensure the device is approved in the destination country.** A list of approved countries appears in the *Radio Certifications* section of the product manual. The Sure Cross wireless products were certified for use in these countries using the antenna that ships with the product. When using other antennas, verify you are not exceeding the transmit power levels allowed by local governing agencies. Consult with Banner Engineering Corp. if the destination country is not on this list.

Banner Engineering Corp. Limited Warranty

Banner Engineering Corp. warrants its products to be free from defects in material and workmanship for one year following the date of shipment. Banner Engineering Corp. will repair or replace, free of charge, any product of its manufacture which, at the time it is returned to the factory, is found to have been defective during the warranty period. This warranty does not cover damage or liability for misuse, abuse, or the improper application or installation of the Banner product.

THIS LIMITED WARRANTY IS EXCLUSIVE AND IN LIEU OF ALL OTHER WARRANTIES WHETHER EXPRESS OR IMPLIED (INCLUDING, WITHOUT LIMITATION, ANY WARRANTY OF MERCHANTABILITY OR FITNESS FOR A PARTICULAR PURPOSE), AND WHETHER ARISING UNDER COURSE OF PERFORMANCE, COURSE OF DEALING OR TRADE USAGE.

This Warranty is exclusive and limited to repair or, at the discretion of Banner Engineering Corp., replacement. **IN NO EVENT SHALL BANNER ENGINEERING CORP. BE LIABLE TO BUYER OR ANY OTHER PERSON OR ENTITY FOR ANY EXTRA COSTS, EXPENSES, LOSSES, LOSS OF PROFITS, OR ANY INCIDENTAL, CONSEQUENTIAL OR SPECIAL DAMAGES RESULTING FROM ANY PRODUCT DEFECT OR FROM THE USE OR INABILITY TO USE THE PRODUCT, WHETHER ARISING IN CONTRACT OR WARRANTY, STATUTE, TORT, STRICT LIABILITY, NEGLIGENCE, OR OTHERWISE.**

Banner Engineering Corp. reserves the right to change, modify or improve the design of the product without assuming any obligations or liabilities relating to any product previously manufactured by Banner Engineering Corp. Any misuse, abuse, or improper application or installation of this product or use of the product for personal protection applications when the product is identified as not intended for such purposes will void the product warranty. Any modifications to this product without prior express approval by Banner Engineering Corp will void the product warranties. All specifications published in this document are subject to change; Banner reserves the right to modify product specifications or update documentation at any time. Specifications and product information in English supersede that which is provided in any other language. For the most recent version of any documentation, refer to: www.bannerengineering.com.

For patent information, see www.bannerengineering.com/patents.