

DATA SHEET

**ELECTROSTATIC DISCHARGE
PROTECTION DEVICES**

INDUSTRIAL / CONSUMER

UDT14A05L03 series

RoHS compliant & Halogen free



Product specification— November 05, 2018 V.0

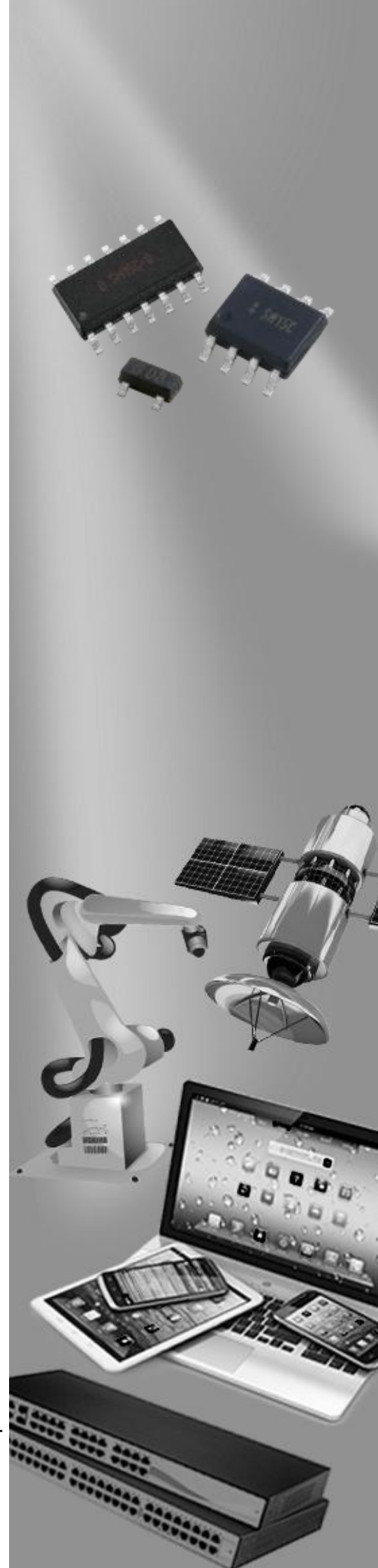

Electrostatic Discharged Protection Devices (ESD) Data Sheet

Description

UDT14A05L03 is surge rated diode arrays designed to protect high speed data interfaces. It has been specifically designed to protect sensitive components which is connected to data and transmission lines from overvoltage caused by electrostatic discharge (ESD), electrical fast transients (EFT), and lightning.

The unique design of the device incorporates one surge rated, and two data lines. Low capacitance steering diodes and a TVS diode in a single package. The low capacitance array configuration allows the user to protect two high speed data or transmission lines.

The two inductance construction minimizes voltage overshoot during high current surges.



Contact : ±8kV
Air : ±15kV



Features

- IEC61000-4-2 ESD 15KV Air, 8KV contact compliance
- SOT-143 surface mount package
- Protects two high-speed data lines and one power line
- Array of surge rated, low capacitance diodes
- Working voltage: 5V
- Low leakage current
- Low clamping voltage
- Solid-state silicon avalanche technology
- RoHS compliant
- Solder reflow temperature: Pure Tin-Sn, 260~270°C
- Flammability rating UL 94V-0
- Meets MSL level 1, per J-STD-020
- Marking: B T05

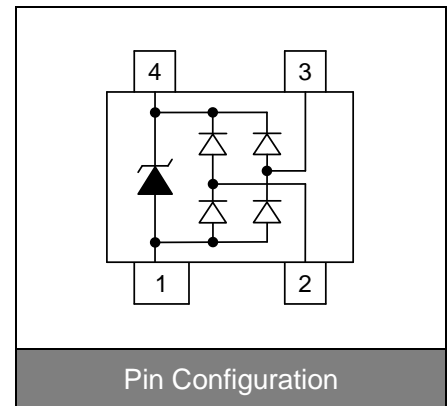

Applications

- USB power and data line protection
- Ethernet 10BaseT
- Video line protection
- I²C bus protection
- WAN/LAN equipment
- ISDN S/T interface
- Microcontroller input protection
- Portable electronics

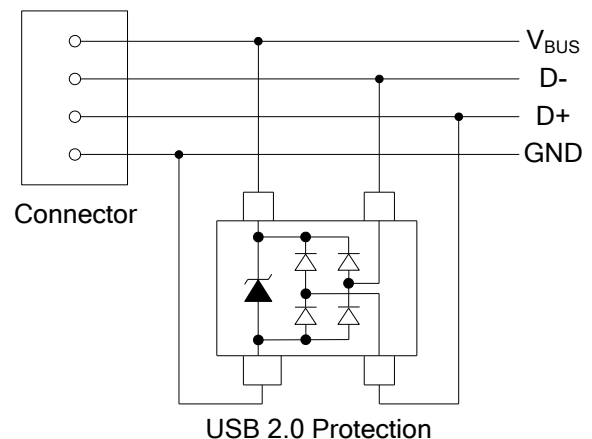

Maximum Ratings

Rating	Symbol	Value	Unit
Peak pulse current (tp=8/20μs waveform)	I_{PP}	12	A
ESD voltage (Contact discharge)	V_{ESD}	±8	kV
ESD voltage (Air discharge)		±15	
Storage & operating temperature range	T_{STG}, T_J	-55~+150	°C

Electrical Characteristics ($T_J=25^{\circ}\text{C}$)

Parameter	Symbol	Condition	Min.	Typ.	Max.	Unit
Reverse stand-off voltage	V_{RWM}				5	V
Reverse breakdown voltage	V_{BR}	$I_{BR}=1\text{mA}$	6			V
Reverse leakage current	I_R	$V_R=5\text{V}$			5	μA
Clamping voltage (tp=8/20μs)	V_C	$I_{PP}=1\text{A}$			9.8	V
Clamping voltage (tp=8/20μs)	V_C	$I_{PP}=12\text{A}$			25	V
Off state junction capacitance	C_J	0Vdc, f=1MHz Between I/O pins and GND		1.5	3	pF

ESD Protection Standards

IEC61000-4-2

Interfaces of consumer electronic equipment are widely specified according to the International Electrotechnical Commission standard IEC61000-4-2. This standard is not targeted towards particular devices but towards general equipment, systems and subsystems that may be involved in electrostatic discharge. consists of a 150pF capacitor and a 330Ω series resistor representing the counterpart to the Device Under Test (DUT).

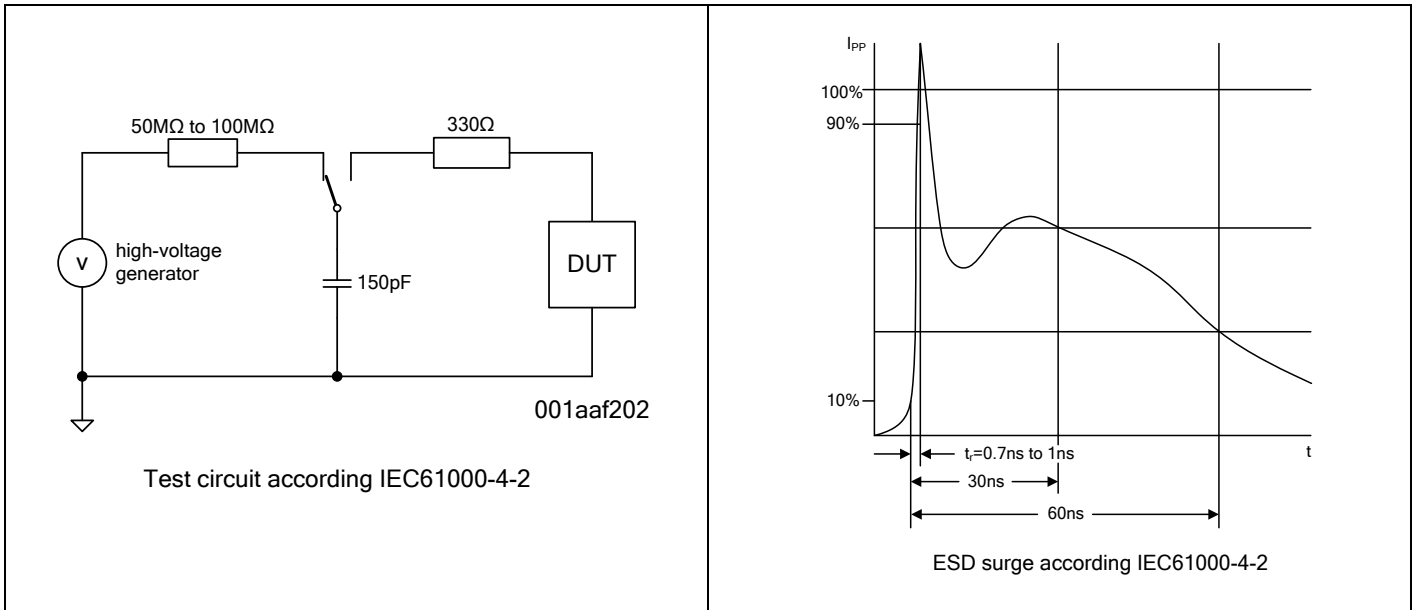

Human Body Model (HBM, MIL-883E method 3015.7)

The HBM standard simulates an ESD surge generated by human contact to electronic components.

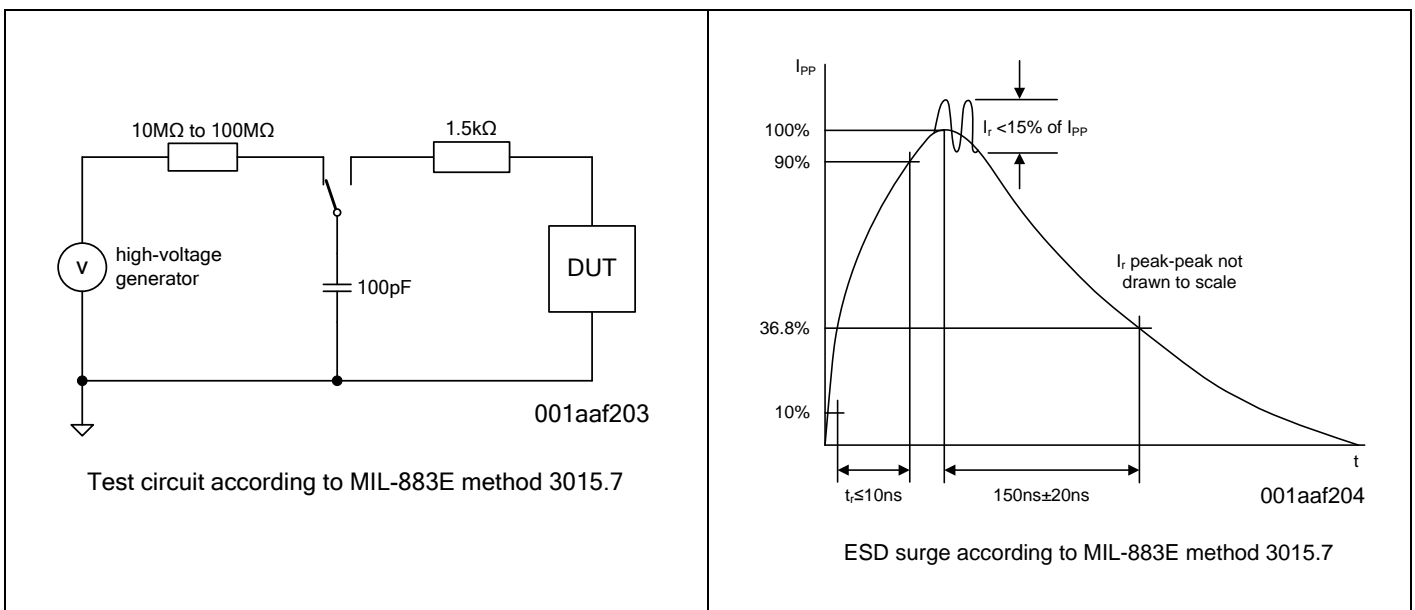

Recommended Soldering Conditions

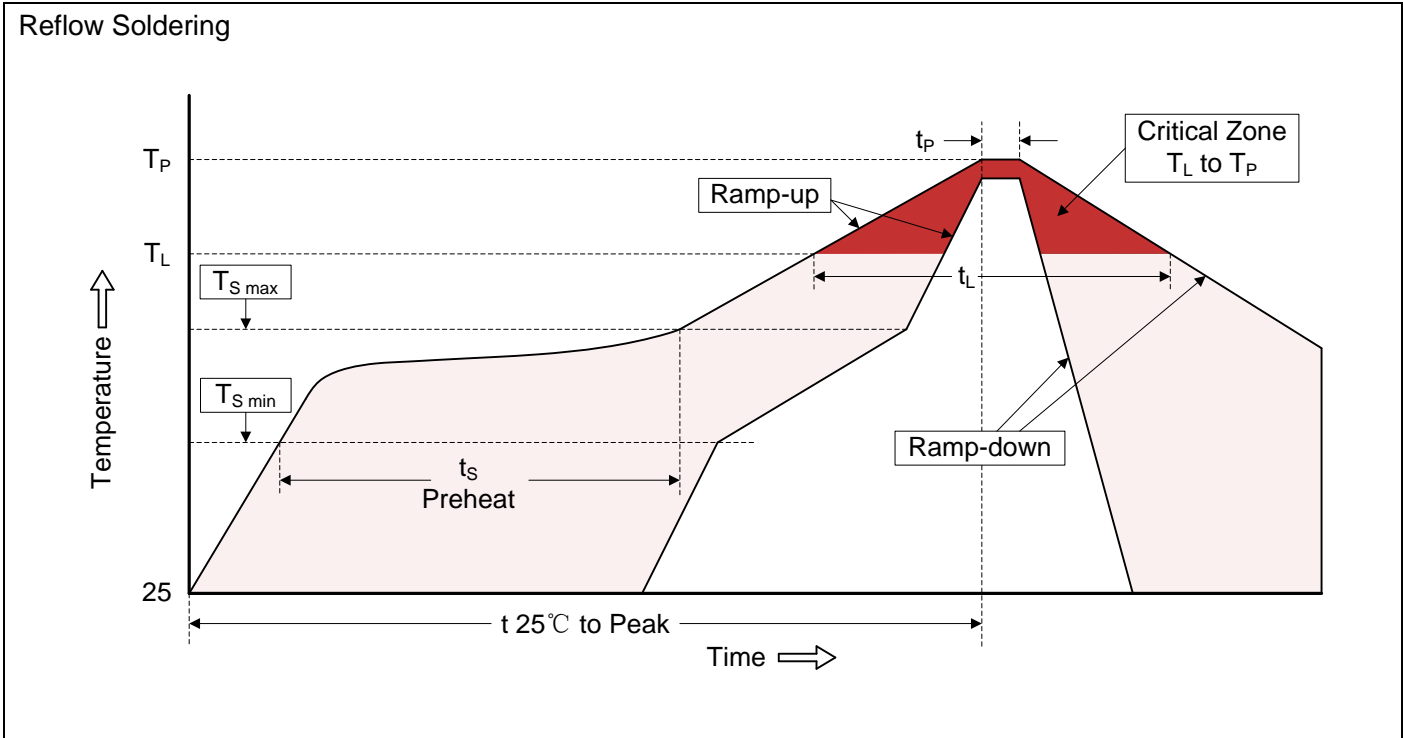

Recommended Conditions

Profile Feature	Pb-Free Assembly
Average ramp-up rate (T_L to T_P)	3°C/second max.
Preheat -Temperature Min ($T_{S\ min}$) -Temperature Max ($T_{S\ max}$) -Time (min to max) (t_s)	150°C 200°C 60-180 seconds
$T_{S\ max}$ to T_L -Ramp-up Rate	3°C/second max.
Time maintained above: -Temperature (T_L) -Time (t_L)	217°C 60-150 seconds
Peak Temperature (T_P)	260°C
Time within 5°C of actual Peak Temperature (t_P)	20-40 seconds
Ramp-down Rate	6°C/second max.
Time 25°C to Peak Temperature	8 minutes max.

Dimensions (SOT-143)

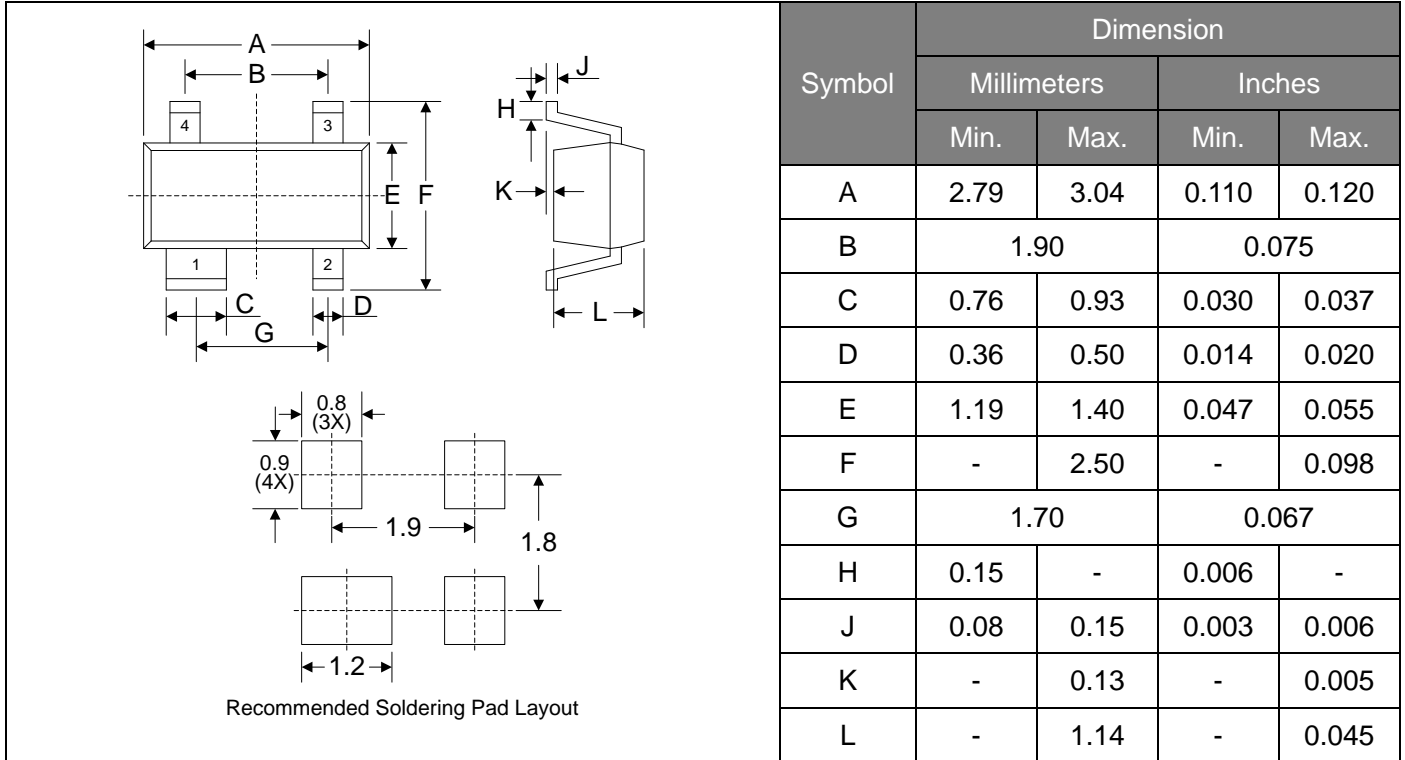

Packaging

