

## XVMB2RA5GSB

indicator bank without buzzer + 3 illuminated units - Ø 45mm - 24VAC/DC



### Main

Range of product	Harmony XVM
Product or component type	Pre-assembled and pre-cabled indicator bank
Beacon or indicator bank unit type	3 illuminated units
Component name	XVM
Light source	Orange super bright LED with BA 15d base flashing signalling Green super bright LED with BA 15d base steady signalling Red super bright LED with BA 15d base steady signalling
Light block color	Red/green/orange (flashing)
[Us] rated supply voltage	24 V AC/DC
Indicator bank base type	Base without buzzer
Mounting mode	Vertical

### Complementary

Kit composition	Aluminium support tube Base unit Cover Plastic fixing plate
Mounting diameter	45 mm
Connections - terminals	Flying leads : 1 x 0.325 mm <sup>2</sup> AWG 22
Marking	CE
Mounting support	Aluminium tube
[Ui] rated insulation voltage	250 V conforming to IEC 60947-1
Nominal voltage limit	0.85...1.1 Un conforming to IEC 60947-5-1
Current consumption	43 mA on steady LED unit 45 mA on flashing LED unit
[Uimp] rated impulse withstand voltage	4 kV conforming to IEC 60947-1
Flashing frequency	1 Hz, flashing LED unit
Product weight	0.443 kg

### Environment

IP degree of protection	IP54 in vertical position conforming to IEC 60529
product certifications	CCC
standards	EN/IEC 60947-1 EN/IEC 60947-5-1
ambient air temperature for storage	-25...70 °C
ambient air temperature for operation	-10...50 °C
overvoltage category	Class I conforming to IEC 61140 Class I conforming to IEC 60947-1 Class I conforming to IEC 60947-5-1
protective treatment	TC

### Offer Sustainability

Sustainable offer status	Green Premium product
RoHS (date code: YYWW)	Compliant - since 1529 - Schneider Electric declaration of conformity
REACH	Reference not containing SVHC above the threshold

The information provided in this documentation contains general descriptions and/or technical characteristics of the products contained herein. This documentation is not intended as a substitute for and is not to be used for determining suitability or reliability of these products for specific user applications. It is the duty of any such user or integrator to perform the appropriate and complete risk analysis, evaluation and testing of the products with respect to the relevant specific application or use thereof. Neither Schneider Electric Industries SAS nor any of its affiliates or subsidiaries shall be responsible or liable for misuse of the information contained herein.

## Contractual warranty

Warranty period

18 months

## Pre-Assembled and Pre-Cabled Tower Light with Fixing Base for Mounting on Vertical Support (Support Tube + Metal Bracket)

### Dimensions

Below drawing shows the maximum configuration of the product. Select the number of stages according to the product characteristics in order to get **b2** dimension.

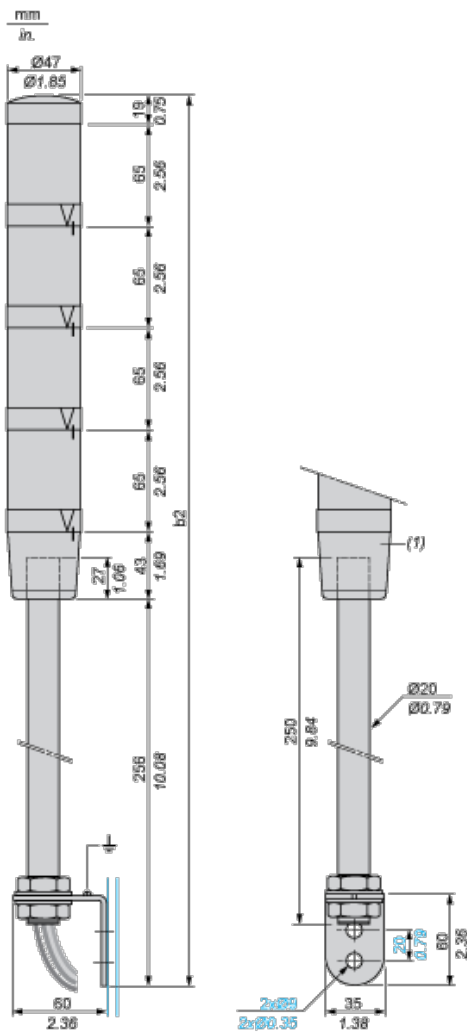

(1) Base unit with or without buzzer.

Number of illuminated units	b2 in mm	b2 in in.
1 unit	383	15.08
2 units	448	17.64
3 units	513	20.20
4 units	578	22.76

## Pre-Assembled and Pre-Cabled Tower Light

### Wire Colors

4th illuminated unit: yellow wire

3rd illuminated unit: green wire

2nd illuminated unit: white wire

1st illuminated unit: blue wire

Common: black wire

Buzzer (if integrated in base unit): grey wire