

MDE0213A122250BW	122 x 250	3-Wire SPI Interface	E-Ink Module
Specification			
Version: 1		Date: 13/08/2018	
Revision			
1	08/01/2018	First Issue.	

Display Features			
Display Size	2.13"		
Resolution	122 x 250		
Orientation	Portrait		
Appearance	Black, White		
Logic Voltage	3.3V		
Interface	SPI		
Touchscreen	N/A		
Module Size	29.20 x 59.20 x 1.05mm		
Operating Temperature	0°C ~ +50°C		
Pinout	24 - Way FFC	Box Quantity	Weight / Display
Pitch	0.5mm	---	---

design • manufacture • supply

* - For full design functionality, please use this specification in conjunction with the SSD1673 specification.(Provided Separately)

Display Accessories	
Part Number	Description

Optional Variants	
Appearances	Voltage



General Description

MDE0213A122250BW is an Active Matrix Electrophoretic Display(AMEPD) , with interface and a reference system design. The 2.13” active area contains 122×250 pixels, and has 1-bit B/W full display capabilities. An integrated circuit contains gate buffer, source buffer, interface, timing control logic, oscillator, DC-DC. SRAM. LUT ,VCOM, and border are supplied with each panel.

Features

- 122×250 pixels display
- White reflectance above 35%
- Contrast ratio above 10:1
- Ultra wide viewing angle
- Ultra low power consumption
- Pure reflective mode
- Bi-stable display
- Commercial temperature range
- Landscape, portrait modes
- Hard-coat antiglare display surface
- Ultra Low current deep sleep mode
- On chip display RAM
- Waveform stored in On-chip OTP
- Serial peripheral interface available
- On-chip oscillator
- On-chip booster and regulator control for generating VCOM, Gate and Source driving voltage
- I²C signal master interface to read external temperature sensor

Application

Electronic Shelf Label System

Mechanical Specifications

Parameter	Specifications	Unit	Remark
Screen Size	2.13	Inch	
Display Resolution	122(H)×250(V)	Pixel	Dpi:130
Active Area	23.80(H)×48.55(V)	mm	
Pixel Pitch	0.1942×0.1943	mm	
Pixel Configuration	Rectangle		
Outline Dimension	29.2(H)×59.2 (V) ×1.05(D)	mm	
Weight	3.0±0. 2	g	



Mechanical Drawing of EPD module

FRONT VIEW

SIDE VIEW

BOTTOM VIEW

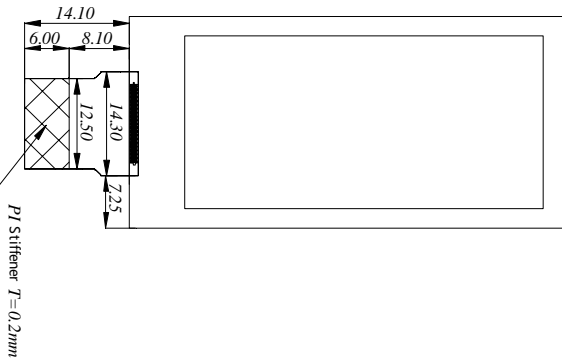
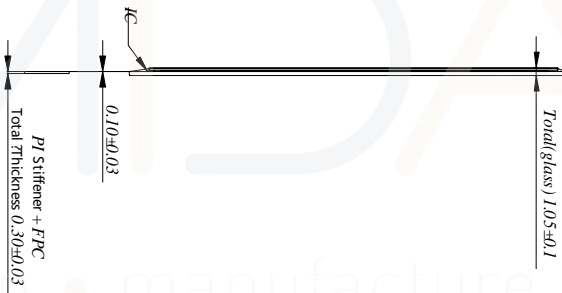
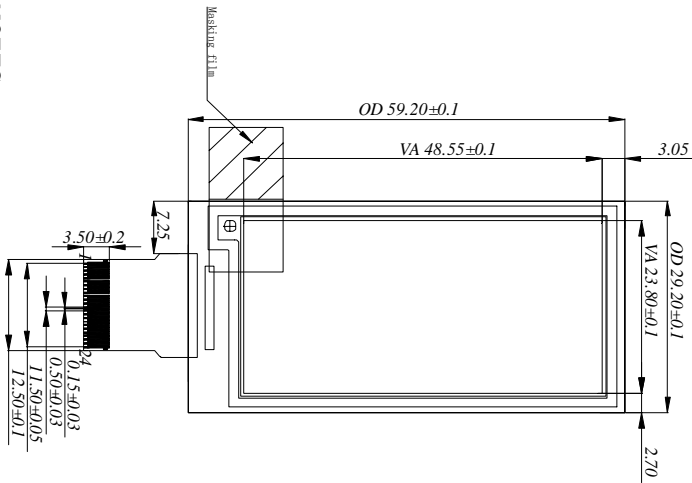

NOTES:

1. DISPLAY MODE 2.13" ARREY FOR EPD;
2. DRIVE IC: SSD1673;
3. RESOLUTION: 250gate X 122source;
4. pixel Pitch: 0.1942mm X 0.1943mm;
5. Unspecified Tolerance: ±0.20;
6. Material conform to the ROHS standard

PIN	SIGNAL
1	NC
2	GDR
3	RESE
4	VGL
5	VGH
6	NC
7	TOUTT
8	BST
9	BLISY
10	RES#
11	D/C#
12	CS#
13	D0
14	D1
15	VDDIO
16	VCL
17	VSS
18	VDD
19	VPP
20	VSH
21	VGH
22	VSL
23	PREVGL
24	VCOM

ALL UNITS: mm	DATE	MODEL NUMBER:		SHEET:
DRAWN: Eisen	30/4/12.23	MDE0213A122250BW		
CHEK: Alan	30/4/12.23	CUSTOMER NO:	PROJECTION	DATE: 30/4/12.23
APP: Donlin	30/4/12.23	DO NOT SCALE THIS DRAWING		

Input/Output Terminals

Pin #	Single	Description	Remark
1	NC	No connection and do not connect with other NC pins	Keep Open
2	GDR	N-Channel MOSFET Gate Drive Control	
3	RESE	Current Sense Input for the Control Loop	
4	VGL	Negative Gate driving voltage	
5	VGH	Positive Gate driving voltage	
6	NC	No connection and do not connect with other NC pins	Keep Open
7	TOUT1	Serial data pin for panel break detection	
8	BS1	Bus selection pin	Note 6-5
9	BUSY	Busy state output pin	Note 6-4
10	RES #	Reset	Note 6-3
11	D/C #	Data /Command control pin	Note 6-2
12	CS #	Chip Select input pin	Note 6-1
13	D0 (SCLK)	serial clock pin (SPI)	
14	D1 (SDIN)	serial data pin (SPI)	
15	VDDIO	Power for interface logic pins	
16	VCI	Power Supply pin for the chip	
17	VSS	Ground	
18	VDD	Core logic power pin	
19	VPP	Power Supply for OTP Programming	
20	VSH	Positive Source driving voltage	
21	VGH	Positive Gate driving voltage	
22	VSL	Negative Source driving voltage	
23	PREVGL	Power Supply pin for VCOM, VGL and VSL	
24	VCOM	VCOM driving voltage	

Note 6-1: This pin (CS#) is the chip select input connecting to the MCU. The chip is enabled for MCU communication: only when CS# is pulled LOW.

Note 6-2: This pin (D/C#) is Data/Command control pin connecting to the MCU. When the pin is pulled HIGH, the data will be interpreted as data. When the pin is pulled LOW, the data will be interpreted as command.

Note 6-3: This pin (RES#) is reset signal input. The Reset is active low.

Note 6-4: This pin (BUSY) is Busy state output pin. When Busy is High the operation of chip should not be interrupted and any commands should not be issued to the module. The driver IC will put Busy pin High when the driver IC is working such as:

- Outputting display waveform; or
- Communicating with digital temperature sensor

Note 6-5: This pin (BS1) is for 3-line SPI or 4-line SPI selection. When it is “Low”, 4-line SPI is selected. When it is “High”, 3-line SPI (9 bits SPI) is selected.

MCU Interface

1. MCU interface selection

The EI213A122250WN can support 3-wire/4-wire serial peripheral interface. In the Module, the MCU interface is pin selectable by BS1 pins shown in.

Table 7-1: MCU interface selection

BS1	MPU Interface
L	4-lines serial peripheral interface (SPI)
H	3-lines serial peripheral interface (SPI) - 9 bits SPI

2. MCU Serial Peripheral Interface (4-wire SPI)

The 4-wire SPI consists of serial clock SCLK, serial data SDIN, D/C# and CS#. In SPI mode, D0 acts as SCLK and D1 acts as SDIN. The control pins status in 4-wire SPI in writing command/data is shown in Table 7-2 and the write procedure 4-wire SPI is shown in Figure 7-2.

Table 7-2 : Control pins status of 4-wire SPI

Function	D0 (SCLK) pin	D1 (SDIN) pin	D/C# pin	CS# pin
Write command	↑	Command bit	L	L
Write data	↑	Data bit	H	L

Note:

- (1) L is connected to VSS and H is connected to VDDIO
- (2) ↑ stands for rising edge of signal
- (3) SDIN is shifted into an 8-bit shift register on every rising edge of SCLK in the order of D7, D6, ... D0. The level of D/C# should be kept over the whole byte. The data byte in the shift register is written to the Graphic Display Data RAM (RAM)/Data Byte register or command Byte register according to D/C# pin.



Messrs.			
Product Specification	Model:	EI213A122250WN	Rev. NO.
			A
			Issued Date.
			Nov.17,17

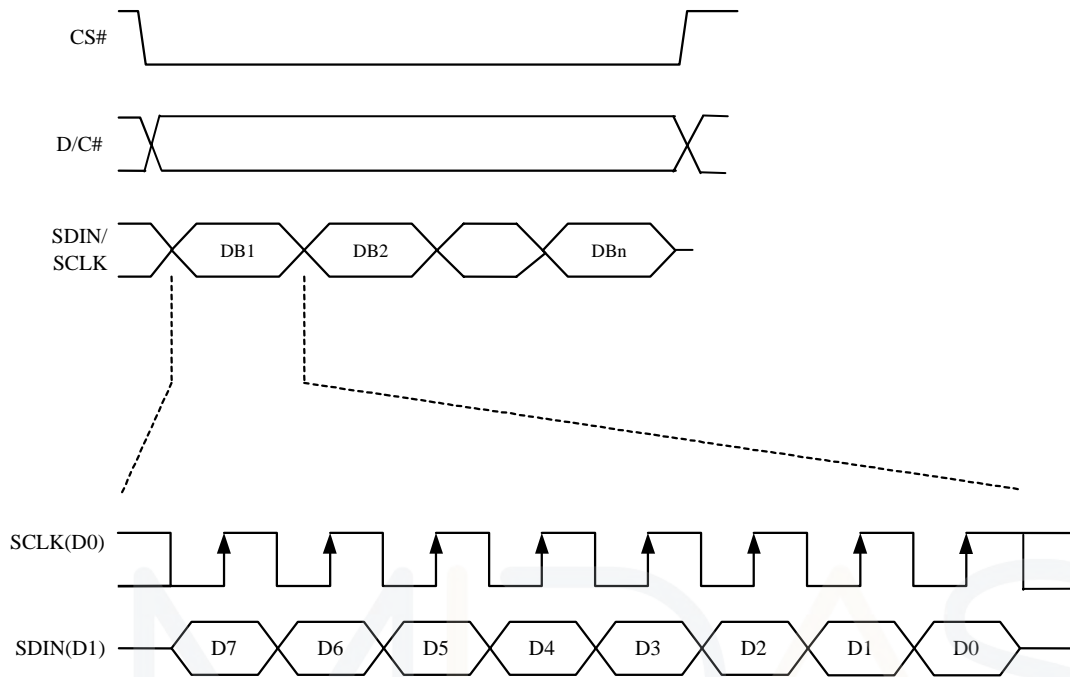

Figure 7-2: Write procedure in 4-wire SPI

design • manufacture • supply



3. MCU Serial Peripheral Interface (3-wire SPI)

The 3-wire SPI consists of serial clock SCLK, serial data SDIN and CS#. In SPI mode, D0 acts as SCLK, D1 acts as SDIN. The operation is similar to 4-wire SPI while D/C# pin is not used and it must be tied to LOW. The control pins status in 3-wire SPI is shown in Table 7-3.

In the write operation, a 9-bit data will be shifted into the shift register on every clock rising edge. The bit shifting sequence is D/C# bit, D7 bit, D6 bit to D0 bit. The first bit is D/C# bit which determines the following byte is command or data. When D/C# bit is 0, the following byte is command. When D/C# bit is 1, the following byte is data. Figure 7- shows the write procedure in 3-wire SPI

Table 7-3 : Control pins status of 3-wire SPI

Function	SCLK pin	SDIN pin	D/C# pin	CS# pin
Write command	↑	Command bit	Tie LOW	L
Write data	↑	Data bit	Tie LOW	L

Note:

- (1)L is connected to V_{SS} and H is connected to V_{DDIO}
- (2)↑ stands for rising edge of signal

Figure 7-3 : Write procedure in 3-wire SPI

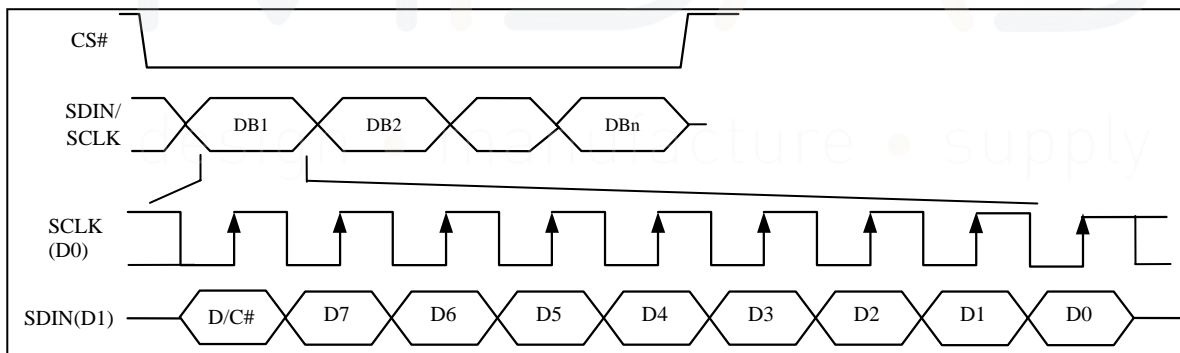

8. Temperature sensor operation

The way how the module get the ambient temperature, first use an external temperature sensor to get the temperature value then converted to hex format, then use the spi interface send command 0x1A and the temperature value into the module. The temperature value how to converted to hex as the follow:

1. If the Temperature value MSByte bit D11 = 0, then

The temperature is positive and value (DegC) = + (Temperature value) / 16

2. If the Temperature value MSByte bit D11 = 1, then

The temperature is negative and value (DegC) = ~ (2's complement of Temperature value) / 16

12-bit binary (2's complement)	Hexadecimal Value	Decimal Value	Value [DegC]
0111 1111 0000	7F0	2032	127
0111 1110 1110	7EE	2030	126.875
0111 1110 0010	7E2	2018	126.125
0111 1101 0000	7D0	2000	125
0001 1001 0000	190	400	25
0000 0000 0010	002	2	0.125
0000 0000 0000	000	0	0
1111 1111 1110	FFE	-2	-0.125
1110 0111 0000	E70	-400	-25
1100 1001 0010	C92	-878	-54.875
1100 1001 0000	C90	-880	-55

Panel Break Detection

The panel break detection function is used to detect the breakage at panel edge. When the panel break detection command is issued, the panel break detection will be executed. During the detection period, BUSY output is at high level. BUSY output is at low level when the detection is completed. Then, user can issue the Status Bit Read command to check the status bit for the result of panel break.



COMMAND TABLE

R/W#	D/C#	Hex	D7	D6	D5	D4	D3	D2	D1	D0	Command	Description						
0	0	01	0	0	0	0	0	0	0	1	Driver Output Control	Set the number of gate. Setting for 232 gates is: Set A[7:0] = F9h Set B[7:0] = 00h						
0	1	-	A7	A6	A5	A4	A3	A2	A1	A0								
0	1	-	0	0	0	0	0	B2	B1	B0								
0	0	03	0	0	0	0	0	0	1	1	Gate Driving Voltage Control	Set Gate driving voltage. A[4:0] = 10h [POR], VGH at 22V B[3:0] = 0Ah [POR], VGL at -20V						
0	1	-	0	0	0	A4	A3	A2	A1	A0								
0	1	-	0	0	0	0	B3	B2	B1	B0								
0	0	04	0	0	0	0	0	1	0	0	Source Driving voltage Control	Set Source output voltage. A[4:0] = 19h [POR], VSH/VSL at +/-15V						
0	1	-	0	0	0	A4	A3	A2	A1	A0								
0	0	10	0	0	0	1	0	0	0	0	Deep Sleep Mode	Deep Sleep mode Control <table border="1"> <tr> <th>A[0]</th> <th>Description</th> </tr> <tr> <td>0</td> <td>Normal Mode [POR]</td> </tr> <tr> <td>1</td> <td>Enter Deep Sleep Mode</td> </tr> </table>	A[0]	Description	0	Normal Mode [POR]	1	Enter Deep Sleep Mode
A[0]	Description																	
0	Normal Mode [POR]																	
1	Enter Deep Sleep Mode																	
0	1	-	0	0	0	0	0	0	0	A0								
0	0	11	0	0	0	1	0	0	0	1	Data Entry mode setting	Define data entry sequence. A [1:0] = ID[1:0] Address automatic increment / decrement setting The setting of incrementing or decrementing of the address counter can be made independently in each upper and lower bit of the address. 00 – Y decrement, X decrement, 01 – Y decrement, X increment, 10 – Y increment, X decrement, 11 – Y increment, X increment [POR] A[2] = AM Set the direction in which the address counter is updated automatically after data is written to the RAM. When AM= 0, the address counter is updated in the X direction. [POR] When AM = 1, the address counter is updated in the Y direction.						
0	1	-	0	0	0	0	0	A2	A1	A0								
0	0	12	0	0	0	1	0	0	1	0	SWRESET	It resets the commands and parameters to their S/W Reset default values except R10h-Deep Sleep Mode Note: RAM are unaffected by this command.						
0	0	1A	0	0	0	1	1	0	1	0	Temperature Sensor Control (Write to temperature register)	Write to temperature register. A[7:0] – MSByte 01111111[POR] B[7:0] – LSByte 11110000[POR]						
0	1	-	A7	A6	A5	A4	A3	A2	A1	A0								
0	1	-	B7	B6	B5	B4	0	0	0	0								
0	0	20	0	0	1	0	0	0	0	0	Master Activation	Activate Display Update Sequence. The Display Update Sequence Option is located at R22h User should not interrupt this operation to avoid corruption of panel images.						

R/W#	D/C#	Hex	D7	D6	D5	D4	D3	D2	D1	D0	Command	Description								
0	0	21	0	0	1	0	0	0	0	1	Display Update Control 1	<p>Option for Display Update Bypass Option used for Pattern Display, which is used for display the RAM content into the Display</p> <p>OLD RAM Bypass option A [7] A[7] = 1: Enable bypass A[7] = 0: Disable bypass [POR]</p> <p>A[4] value will be used as New RAM for bypass. A[4] = 0 [POR]</p> <p>A[1:0] Initial Update Option - Source Control</p> <table border="1"> <tr> <td>A[1:0]</td> <td>GSA</td> <td>GSB</td> </tr> <tr> <td>01[POR]</td> <td>GS0</td> <td>GS1</td> </tr> </table>	A[1:0]	GSA	GSB	01[POR]	GS0	GS1		
A[1:0]	GSA	GSB																		
01[POR]	GS0	GS1																		
0	1	-	A7	A6	A5	A4	A3	A2	A1	A0										
0	0	22	0	0	1	0	0	0	1	0	Display Update Control 2	<p>Display Update Sequence Option: Enable the stage for Master Activation</p> <table border="1"> <tr> <td></td> <td>Parameter (in Hex)</td> </tr> <tr> <td>Enable Clock Signal, Then Enable Analog Then Load LUT Then INITIAL DISPLAY Then PATTERN DISPLAY Then Disable Analog Then Disable OSC</td> <td>FF [POR]</td> </tr> <tr> <td>Setting for LUT from OTP Enable Clock Signal, Then Enable Analog Then Load LUT Then PATTERN DISPLAY Then Disable Analog Then Disable OSC</td> <td>D7</td> </tr> <tr> <td>Setting for LUT from MCU Enable Clock Signal, Then Enable Analog Then PATTERN DISPLAY Then Disable Analog Then Disable OSC</td> <td>C7</td> </tr> </table>		Parameter (in Hex)	Enable Clock Signal, Then Enable Analog Then Load LUT Then INITIAL DISPLAY Then PATTERN DISPLAY Then Disable Analog Then Disable OSC	FF [POR]	Setting for LUT from OTP Enable Clock Signal, Then Enable Analog Then Load LUT Then PATTERN DISPLAY Then Disable Analog Then Disable OSC	D7	Setting for LUT from MCU Enable Clock Signal, Then Enable Analog Then PATTERN DISPLAY Then Disable Analog Then Disable OSC	C7
	Parameter (in Hex)																			
Enable Clock Signal, Then Enable Analog Then Load LUT Then INITIAL DISPLAY Then PATTERN DISPLAY Then Disable Analog Then Disable OSC	FF [POR]																			
Setting for LUT from OTP Enable Clock Signal, Then Enable Analog Then Load LUT Then PATTERN DISPLAY Then Disable Analog Then Disable OSC	D7																			
Setting for LUT from MCU Enable Clock Signal, Then Enable Analog Then PATTERN DISPLAY Then Disable Analog Then Disable OSC	C7																			
0	1	-	A7	A6	A5	A4	A3	A2	A1	A0										
0	0	23	0	0	1	0	0	0	1	1	Panel Break Detection	After this command is issued, panel break detection will start. The status can be checked by Command 2Fh. During detection, BUSY pad will output high. The command required CLKEN=1.								
0	0	24	0	0	1	0	0	1	0	0	Write RAM	After this command, data entries will be written into the RAM until another command is written. Address pointers will advance accordingly.								



R/W#	D/C#	Hex	D7	D6	D5	D4	D3	D2	D1	D0	Command	Description
0	0	44	0	1	0	0	0	1	0	0	Set RAM X - address Start / End position	Specify the start/end positions of the window address in the X direction by an address unit A[4:0]: X-Start, POR = 00h B[4:0]: X-End, POR = 12h
0	1	-	0	0	0	A4	A3	A2	A1	A0		
0	1	-	0	0	0	B4	B3	B2	B1	B0		
0	0	45	0	1	0	0	0	1	0	1	Set Ram Y- address Start / End position	Specify the start/end positions of the window address in the Y direction by an address unit A[7:0]: Y-Start, POR = 00h B[7:0]: Y-End, POR = F9h
0	1	-	A7	A6	A5	A4	A3	A2	A1	A0		
0	1	-	B7	B6	B5	B4	B3	B2	B1	B0		
0	0	4E	0	1	0	0	1	1	1	0	Set RAM X - address counter	Make initial settings for the RAM X address in the address counter (AC) A[4:0] : POR is 00h
0	1	-	0	0	0	A4	A3	A2	A1	A0		
0	0	4F	0	1	0	0	1	1	1	1	Set RAM Y - address counter	Make initial settings for the RAM Y address in the address counter (AC) A[7:0] : POR is 00h
0	1	-	A7	A6	A5	A4	A3	A2	A1	A0		

MIDAS

design • manufacture • supply



Reference Circuit

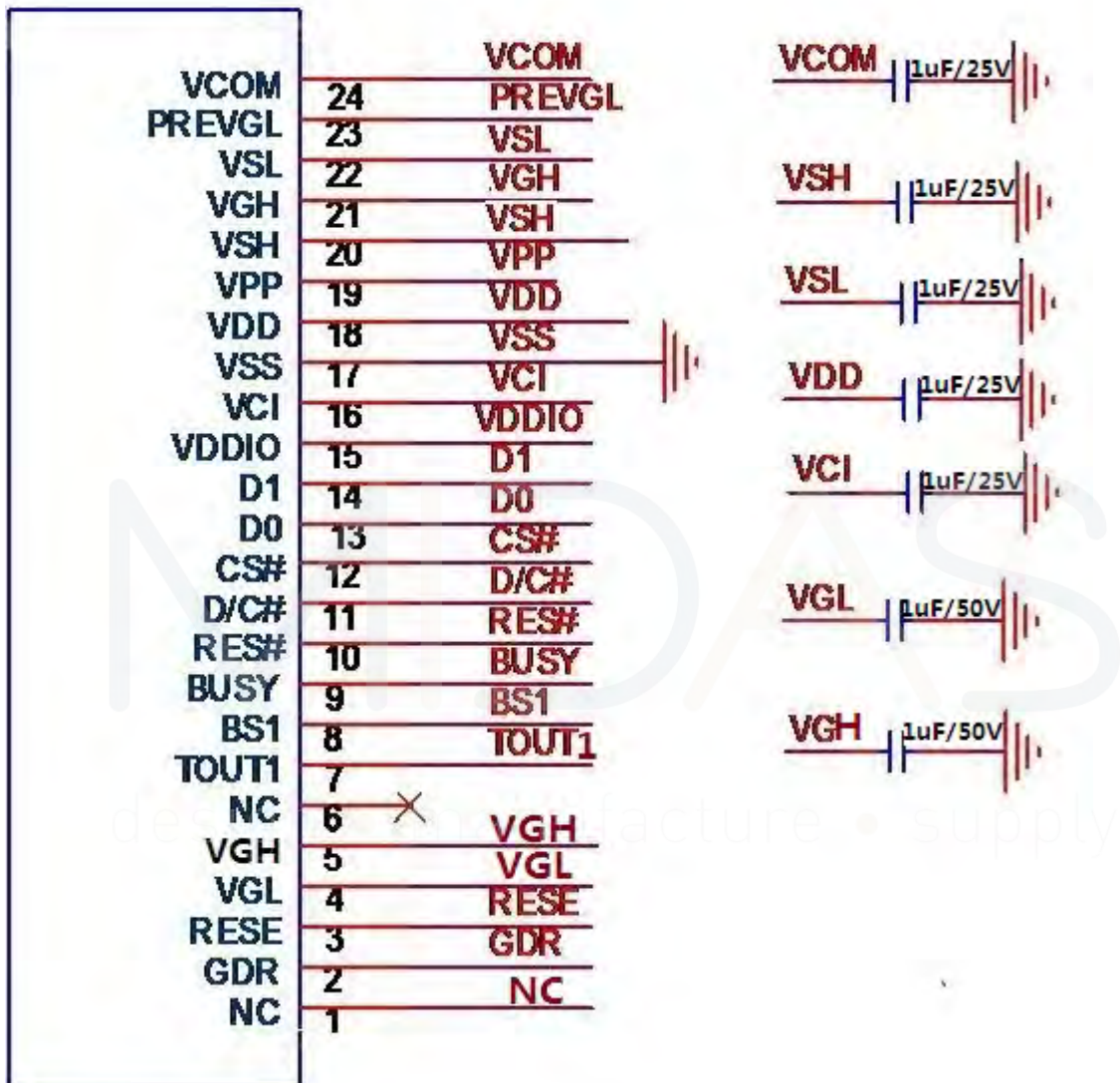

Figure . 11-1

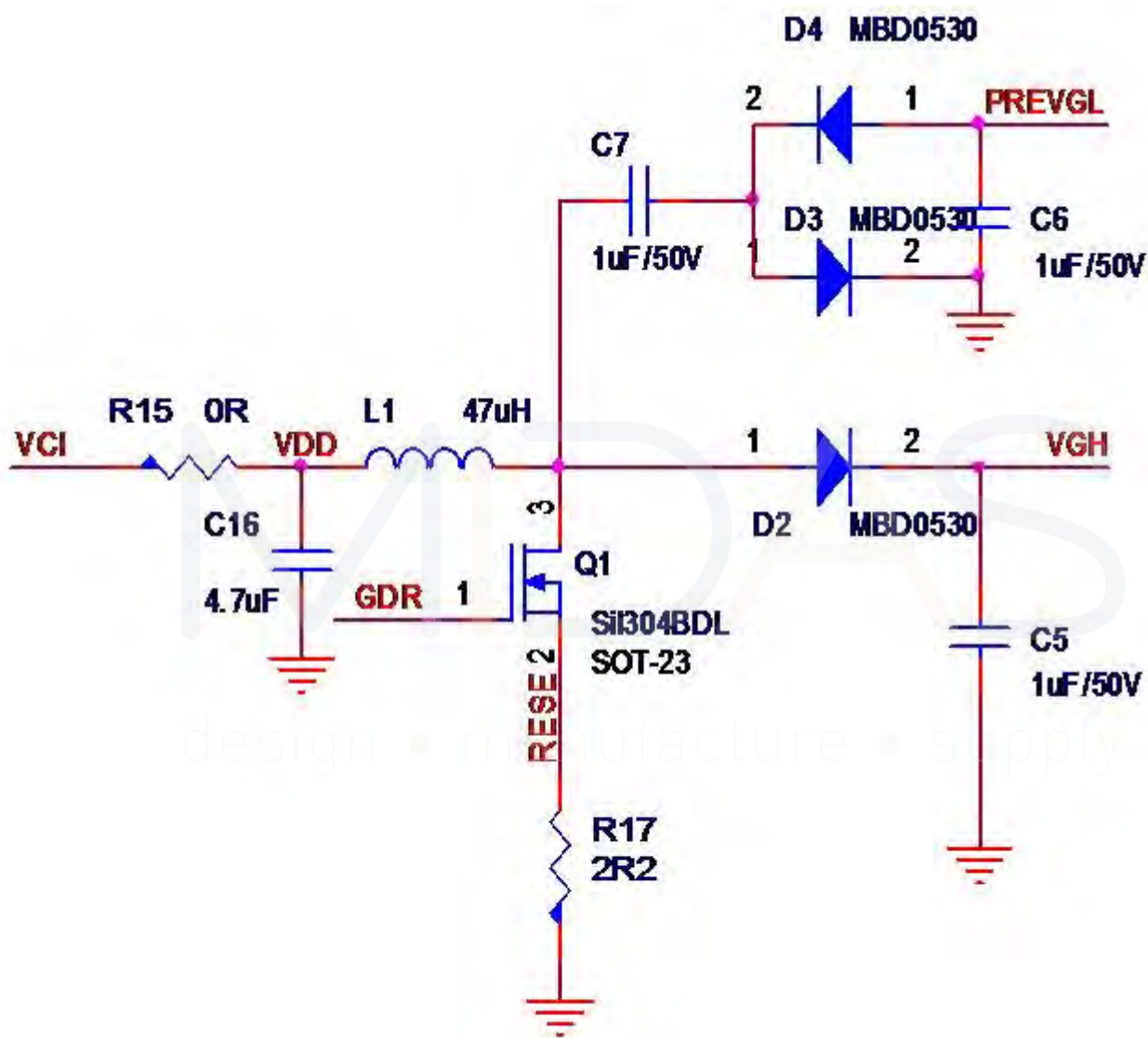

Figure . 11-2



ABSOLUTE MAXIMUM RATING

Table 12-1: Maximum Ratings

Symbol	Parameter	Rating	Unit
V _{CI}	Logic supply voltage	-0.5 to +4.0	V
T _{OPR}	Operation temperature range	0 to 50	°C
T _{STG}	Storage temperature range	-25 to 60	°C

DC CHARACTERISTICS

The following specifications apply for: VSS=0V, VCI=3.3V, T_{OPR}=25°C.

Table 13-1: DC Characteristics

Symbol	Parameter	Test Condition	Applicable pin	Min.	Typ.	Max.	Unit
V _{CI}	VCI operation voltage		VCI	2.4	3.3	3.7	V
V _{IH}	High level input voltage		D1 (SDIN), D0 (SCLK), CS#, D/C#, RES#, BS1	0.8V _{CI}			V
V _{IL}	Low level input voltage					0.2V _{CI}	V
V _{OH}	High level output voltage	I _{OH} = -100uA	BUSY, TOUT1	0.9V _{CI}			V
V _{OL}	Low level output voltage	I _{OL} = 100uA				0.1V _{CI}	V
I _{update}	Module operating current			-	2.8	3.5	mA
I _{sleep}	Deep sleep mode	V _{CI} =3.3V		-	-	2	uA

- The Typical power consumption is measured using associated 25°C waveform with following pattern transition: from horizontal scan pattern to vertical scan pattern. (Note 11-1)
- The listed electrical/optical characteristics are only guaranteed under the controller & waveform provided by Midas.
- Vcom value will be OTP before in factory.

Note13-1

The Typical power consumption

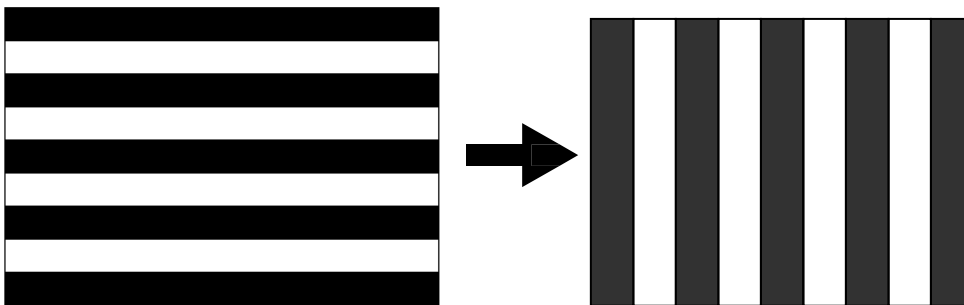

Serial Peripheral Interface Timing

The following specifications apply for: VSS=0V, VCI=2.4V to 3.7V, T_{OPR}=25°C

Symbol	Parameter	Min	Typ	Max	Unit
t _{cycle}	Clock Cycle Time	250	-	-	ns
t _{AS}	Address Setup Time	150	-	-	ns
t _{AH}	Address Hold Time	150	-	-	ns
t _{CSS}	Chip Select Setup Time	120	-	-	ns
t _{CSH}	Chip Select Hold Time	60	-	-	ns
t _{DSW}	Write Data Setup Time	50	-	-	ns
t _{DHW}	Write Data Hold Time	15	-	-	ns
t _{CLKL}	Clock Low Time	100	-	-	ns
t _{CLKH}	Clock High Time	100	-	-	ns
t _R	Rise Time [20% ~ 80%]	-	-	15	ns
t _F	Fall Time [20% ~ 80%]	-	-	15	ns

Figure 14-1 : Serial peripheral interface characteristics

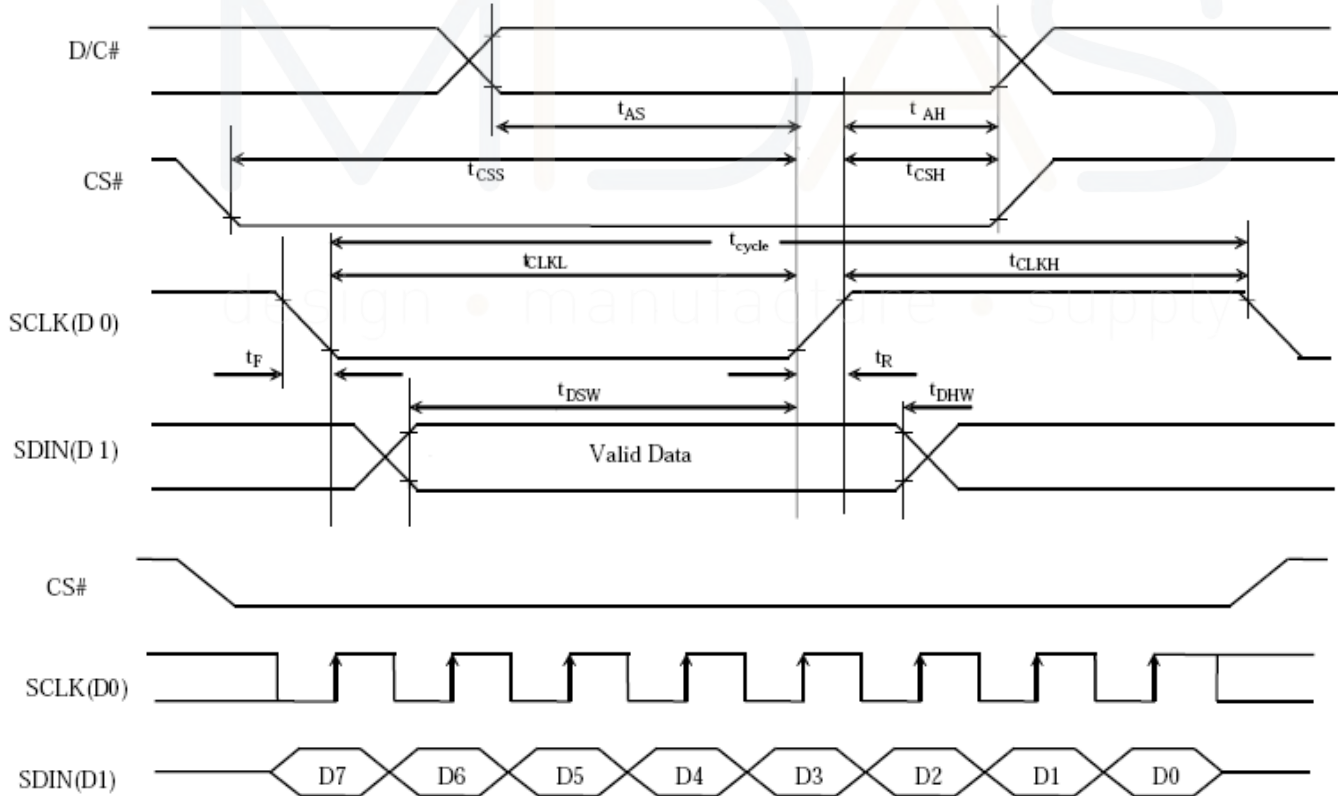

Power Consumption

Parameter	Symbol	Conditions	TYP	Max	Unit	Remark
Panel power consumption during update	-	25°C	10	-	mAs	-
Deep sleep mode	-	25°C	-	2	uA	-

Typical Operating Sequence

1. Normal Operation Flow

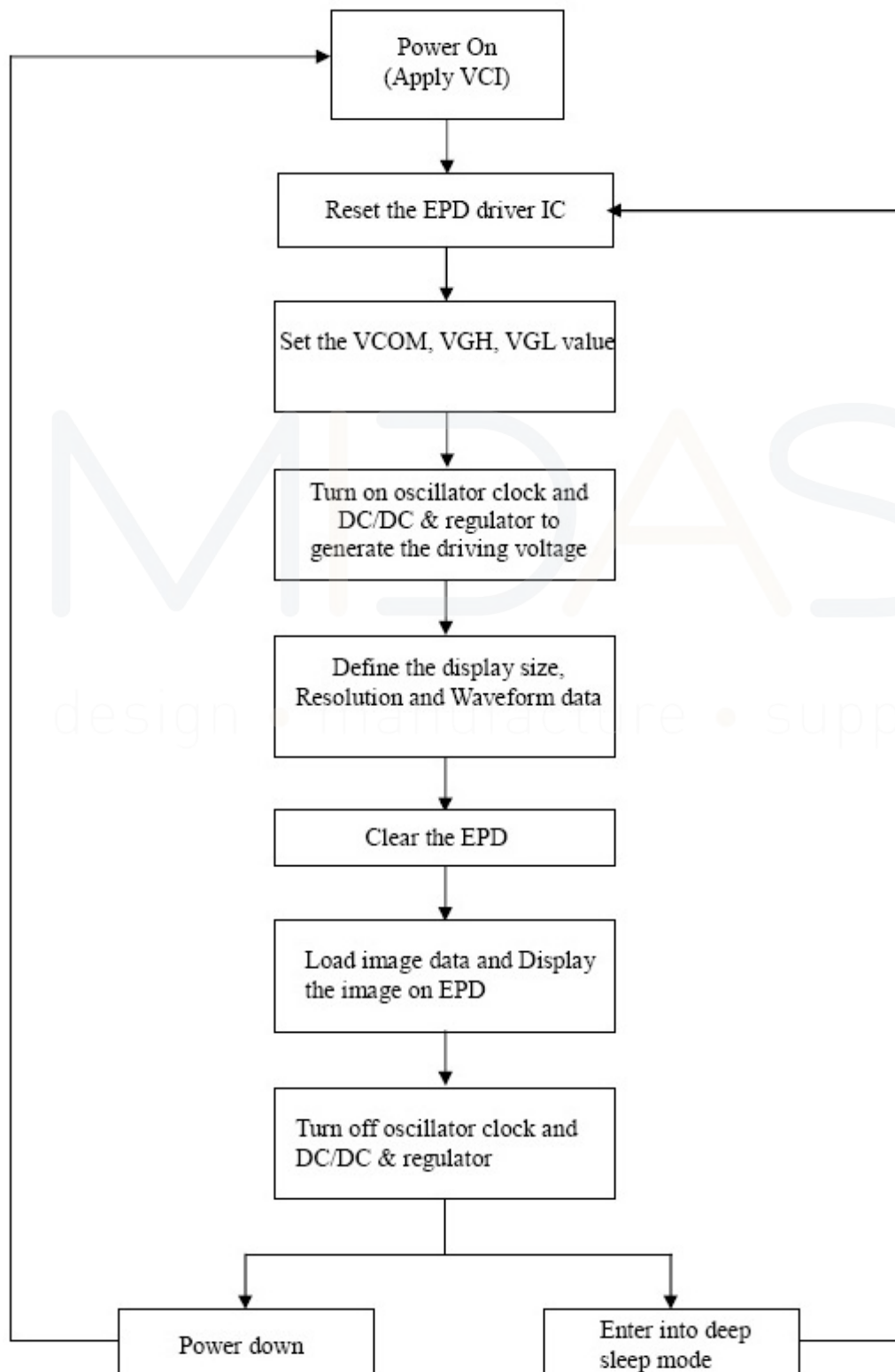

2. Reference Program Code

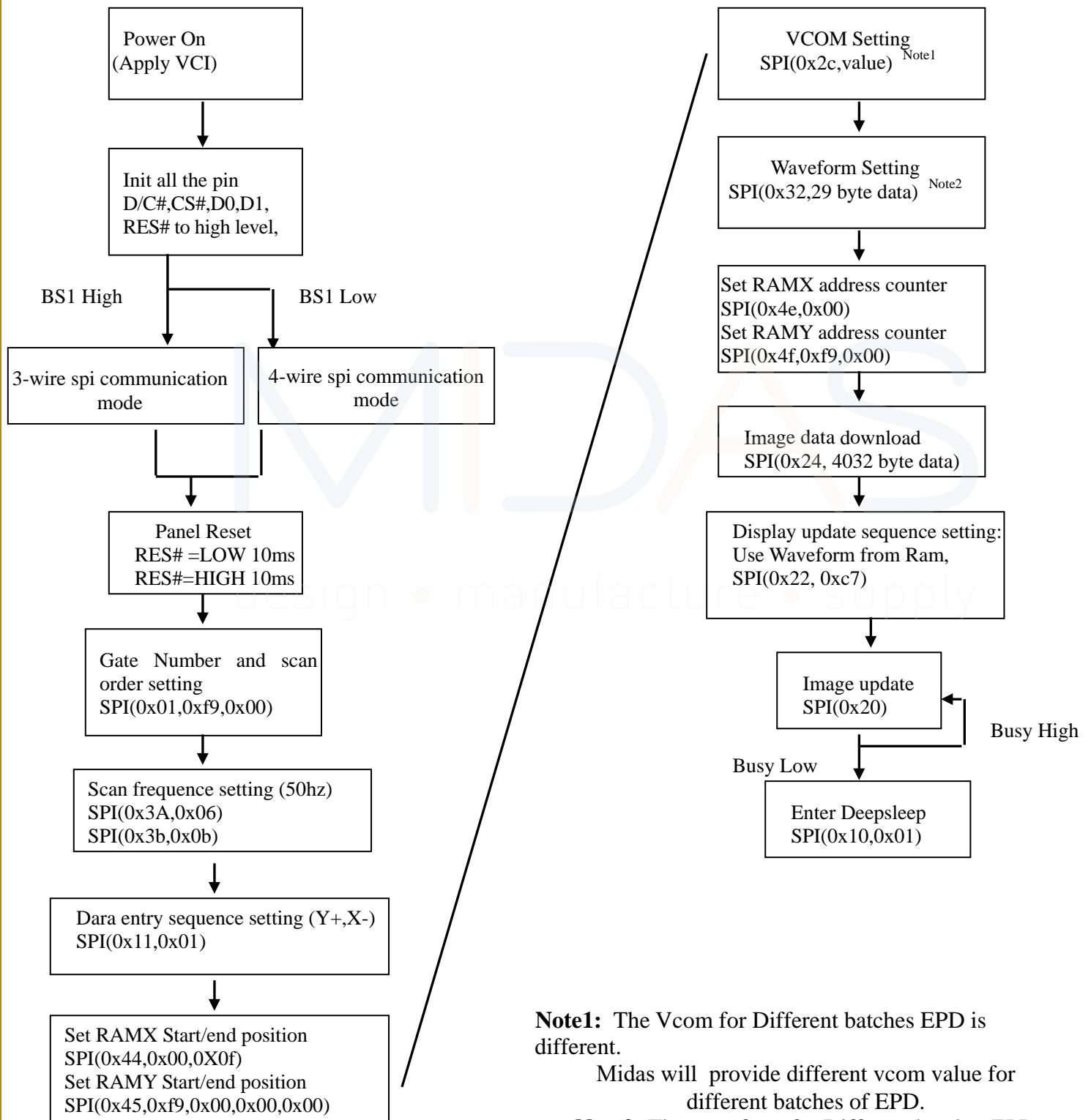

Note1: The Vcom for Different batches EPD is different.

Midas will provide different vcom value for different batches of EPD.

Note2: The waveform for Different batches EPD is different. Midas will provide different waveform for different batches of EPD.



Optical characteristics

1. Specifications

Measurements are made with that the illumination is under an angle of 45 degrees, the detection is perpendicular unless otherwise specified.

T=25°C

SYMBOL	PARAMETER	CONDITIONS	MIN	TYPE	MAX	UNIT	Note
R	Reflectance	White	30	35	-	%	Note 17-1
Gn	2Grey Level	-	-	$DS+(WS-DS)\times n(m-1)$	-	L*	-
CR	Contrast Ratio	indoor	-	10	-	-	-
Panel's life	-	0°C ~ 50°C		5years or 1000000 times	-	-	Note 17-2

WS: White state, DS : Dark state

m: 2

Note 17-1: Luminance meter : Eye - One Pro Spectrophotometer

Note 17-2: We guarantee display quality from 5°C ~ 30°C generally, If operation ambient temperature from 0°C ~ 50°C, will Offer special built-in temperature sensor.

design • manufacture • supply



2. Definition of contrast ratio

The contrast ratio (CR) is the ratio between the reflectance in a full white area (R1) and the reflectance in a dark area (Rd):

R1: white reflectance Rd: dark reflectance

$$CR = R1/Rd$$

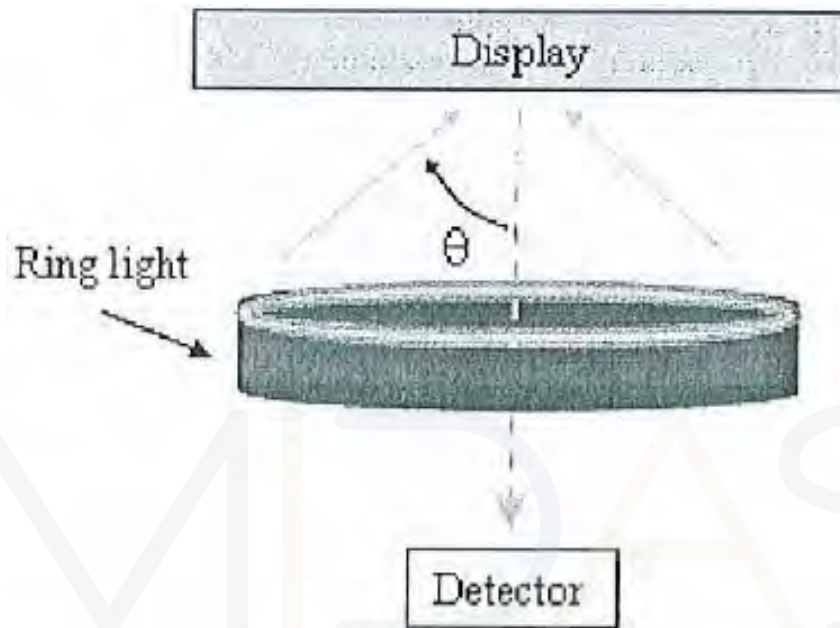

3. Reflection Ratio

The reflection ratio is expressed as :

$$R = \text{Reflectance Factor}_{\text{white board}} \times (L_{\text{center}} / L_{\text{white board}})$$

L_{center} is the luminance measured at center in a white area ($R=G=B=1$). $L_{\text{white board}}$ is the luminance of a standard white board. Both are measured with equivalent illumination source. The viewing angle shall be no more than 2 degrees.

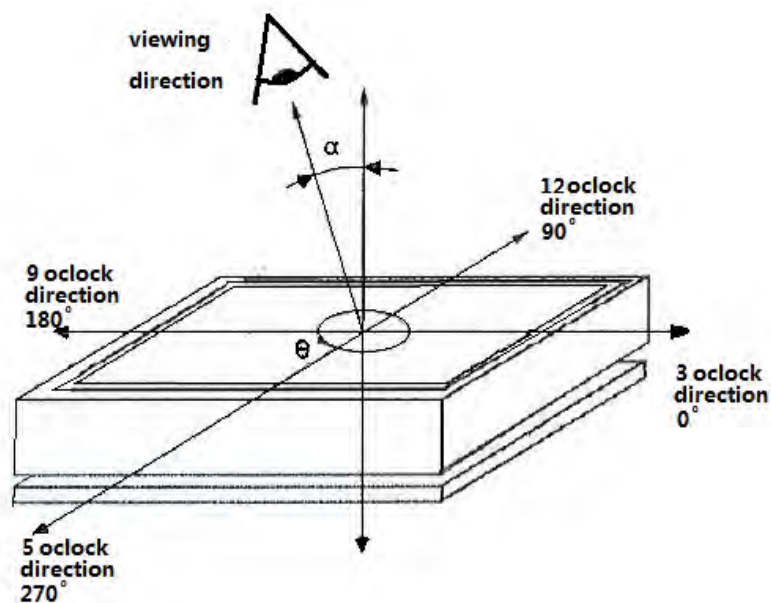

HANDLING, SAFETY AND ENVIRONMENTAL REQUIREMENTS

WARNING

The display glass may break when it is dropped or bumped on a hard surface. Handle with care. Should the display break, do not touch the electrophoretic material. In case of contact with electrophoretic material, wash with water and soap.

CAUTION

The display module should not be exposed to harmful gases, such as acid and alkali gases, which corrode electronic components.

Disassembling the display module can cause permanent damage and invalidate the warranty agreements.

IPA solvent can only be applied on active area and the back of a glass. For the rest part, it is not allowed.

Observe general precautions that are common to handling delicate electronic components. The glass can break and front surfaces can easily be damaged. Moreover the display is sensitive to static electricity and other rough environmental conditions.

Mounting Precautions

(1) It's recommended that you consider the mounting structure so that uneven force (ex. Twisted stress) is not applied to the module.

(2) It's recommended that you attach a transparent protective plate to the surface in order to protect the EPD. Transparent protective plate should have sufficient strength in order to resist external force.

(3) You should adopt radiation structure to satisfy the temperature specification.

(4) Acetic acid type and chlorine type materials for the cover case are not desirable because the former generates corrosive gas of attacking the PS at high temperature and the latter causes circuit break by electro-chemical reaction.

(5) Do not touch, push or rub the exposed PS with glass, tweezers or anything harder than HB pencil lead. And please do not rub with dust clothes with chemical treatment. Do not touch the surface of PS for bare hand or greasy cloth. (Some cosmetics deteriorate the PS)

(6) When the surface becomes dusty, please wipe gently with absorbent cotton or other soft materials like chamois soaks with petroleum benzene. Normal-hexane is recommended for cleaning the adhesives used to attach the PS. Do not use acetone, toluene and alcohol because they cause chemical damage to the PS.

(7) Wipe off saliva or water drops as soon as possible. Their long time contact with PS causes deformations and color fading.

Product specification

The data sheet contains final product specifications.



Limiting values

Limiting values given are in accordance with the Absolute Maximum Rating System (IEC 134). Stress above one or more of the limiting values may cause permanent damage to the device. These are stress ratings only and operation of the device at these or any other conditions above those given in the Characteristics sections of the specification is not implied. Exposure to limiting values for extended periods may affect device reliability.
--

Application information

Where application information is given, it is advisory and does not form part of the specification.

Product Environmental certification
--

ROHS

REMARK

All The specifications listed in this document are guaranteed for module only. Post-assembled operation or component(s) may impact module performance or cause unexpected effect or damage and therefore listed specifications is not warranted after any Post-assembled operation.

MIDAS
design • manufacture • supply



Reliability test

	TEST	CONDITION	METHOD	REMARK
1	High-Temperature Operation	T=50°C, RH=35%RH, For 240Hr	IEC 60 068-2-2Bb	
2	Low-Temperature Operation	T = 0°C for 240 hrs	IEC 60 068-2-2Ab	
3	High-Temperature Storage	T=70°C RH=40%RH For 240Hr Test in white pattern	IEC 60 068-2-2Bb	
4	Low-Temperature Storage	T = -25°C for 240 hrs Test in white pattern	IEC 60 068-2-2Ab	
5	High Temperature, High-Humidity Operation	T=40°C, RH=90%RH, For 168Hr	IEC 60 068-2-3CA	
6	High Temperature, High-Humidity Storage	T=60°C, RH=80%RH, For 480Hr Test in white pattern	IEC 60 068-2-3CA	
7	Temperature Cycle	-25°C(30min)~70°C(30min), 50 Cycle Test in white pattern	IEC 60 068-2-14NB	
8	Package Vibration	1.04G,Frequency : 10~500Hz Direction : X,Y,Z Duration:1hours in each direction	Full packed for shipment	
9	Package Drop Impact	Drop from height of 122 cm on Concrete surface Drop sequence:1 corner, 3edges, 6face One drop for each.	Full packed for shipment	
10	UV exposure Resistance	765 W/m ² for 168hrs,40°C	IEC 60068-2-5 Sa	
11	Electrostatic discharge	Machine model: +/-250V,0 Ω,200pF	IEC61000-4-2	

Actual EMC level to be measured on customer application.

Note1: The protective film must be removed before temperature test.

Note2: Stay white pattern for storage and non-operation test.



Block Diagram

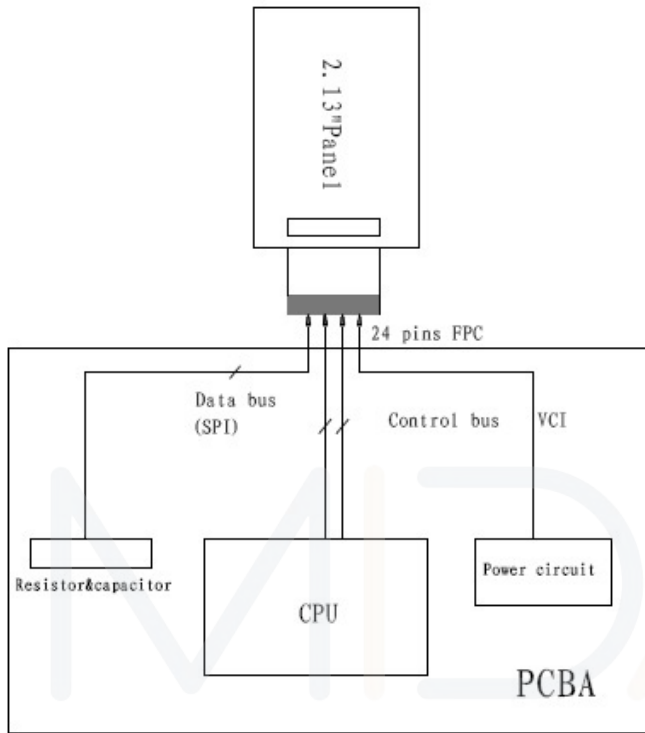

PartA/PartB specification

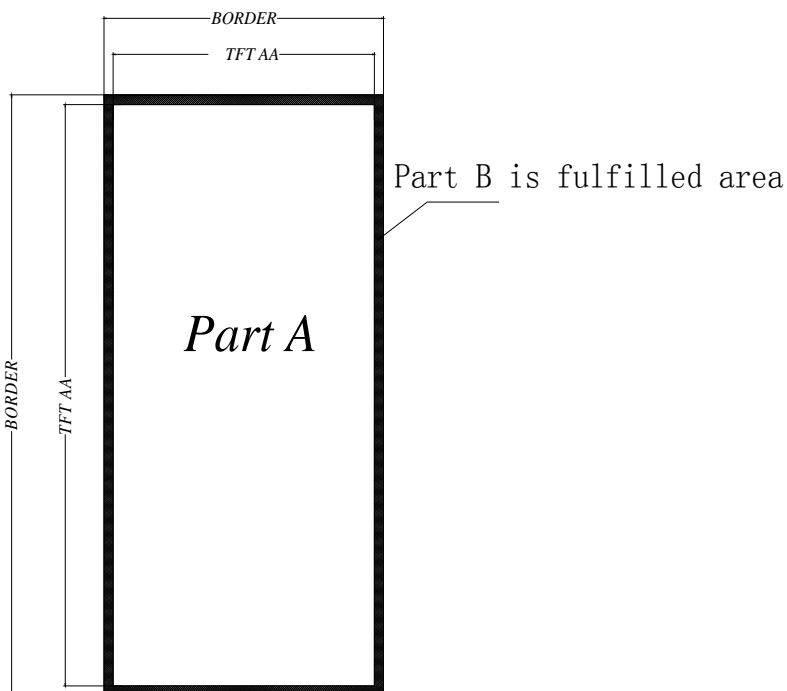

Point and line standard

Shipment Inspection Standard						
Equipment: Electrical test fixture, Point gauge						
Outline dimension	29.2(H) × 59.2(V) × 1.05(D)	Unit: mm	Part-A	Active area	Part-B	Border area
Environment	Temperature	Humidity	Illuminance	Distance	Time	Angle
	19°C ~ 25°C	55% ± 5%RH	800 ~ 1300Lux	300 mm	35Sec	
Defet type	Inspection method	Standard		Part-A	Part-B	
Spot	Electric Display	D ≤ 0.25 mm		Ignore	Ignore	
		0.25 mm < D ≤ 0.4 mm		N ≤ 4	Ignore	
		D > 0.4 mm		Not Allow	Ignore	
Display unwork	Electric Display	Not Allow		Not Allow	Ignore	
Display error	Electric Display	Not Allow		Not Allow	Ignore	
Scratch or line defect(include dirt)	Visual/Film card	L ≤ 2 mm, W ≤ 0.2 mm		Ignore	Ignore	
		2.0mm < L ≤ 5.0mm, 0.2 < W ≤ 0.3mm,		N ≤ 2	Ignore	
		L > 5 mm, W > 0.3 mm		Not Allow	Ignore	
PS Bubble	Visual/Film card	D ≤ 0.2mm		Ignore	Ignore	
		0.2mm ≤ D ≤ 0.35mm & N ≤ 4		N ≤ 4	Ignore	
		D > 0.35 mm		Not Allow	Ignore	
Side Fragment	Visual/Film card	X ≤ 5mm, Y ≤ 0.5mm, Do not affect the electrode circuit, Ignore				
						
Remark	1. Cannot be defect & failure cause by appearance defect;					
	2. Cannot be larger size cause by appearance defect;					
	L=long W=wide D=point size N=Defects NO					



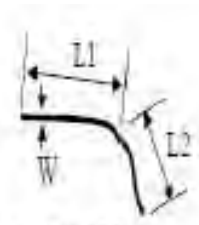

$$L = L1 - L2$$

Line Defect



$$D = (L + W) / 2$$

Spot Defect

L=long W=wide D=point size

MIDAS

design • manufacture • supply

