

OLS2 Series

Optical liquid level sensor - External M12 mount



- Low cost sensors for general liquid sensing
- High reliability optical sensing
- External mount via M12x1 thread
- Standard temperature range -25°C to +80°C
Extended temperature range -40°C to +125°C
- High and Low output versions
- Resistant to false triggering caused by foaming

The OLS2 series is a liquid level sensor for single point liquid level detection.

The sensor has an infra-red emitter and detector aligned within an accurately shaped cone to give good optical coupling when the sensor is in air. This coupling is greatly reduced, when the sensor is immersed in liquid, as the infra-red light escapes through the liquid rather than being reflected back to the detector.

The sensor has a transistor output, so can be configured by the user for particular applications.

Output is via TTL compatible push pull output.

Technical Specification

Mounting style	External	Cable length - standard	25cm
Mounting thread	M12x1	Wire size	24AWG
Body material	Polysulfone UDEL 1700	Cable conductor material	Tinned copper
Temperature Range	-25 to +80°C/-40° to +125°C	Wire sheath material	PTFE
Maximum pressure	7bar	Wire temperature rating	125°C
Tightening torque for fixing	1.5Nm/13.26lbs in	Sealing gasket	Not supplied
Mounting hole	12mm		

Note. LLPK1 - 'O' ring and M12 nut kit - is available as an optional extra.

Electrical Specification

Supply Voltage (Vs)	Vdc	4.5 to 15.4	or	10 to 28
Supply Current Max (Is)	mA	2.5 (Vs = 15.4Vdc)		
Output type	Voltage High or Low (L in part number indicates low)			
Output Voltage (Vout) @ Iout=100mA	Output High Vout = Vs-1V max	Output Low Vout = 0.5Vmax		
Output Sink & Source Current Iout	100mA max	or	1A	

Sensor connections Red= supply +ve, Blue= common(0V), Green= Output (see wiring diagrams overleaf)

Standard Parts

Standard Parts	Mount	Temp Range °C	Supply Volts V	Output
OLS200D3SH	M12x1	-25 to +80	5 to 15dc	High in air Volts
OLS200D3LSH	M12x1	-25 to +80	5 to 15dc	Low in air Volts
OLS210D3SH	M12x1	-40 to +125	5 to 15dc	High in air Volts
OLS210D3LSH	M12x1	-40 to +125	5 to 15dc	Low in air Volts
OLS210D324-003	M12x1	-40 to +125	10 to 28dc	High in air Open drain
OLS210D3L24-003	M12x1	-40 to +125	10 to 28dc	Low in air Open drain

Custom versions can be made for particular applications. Please contact Cynergy3 with your requirements.

Mechanical Dimensions

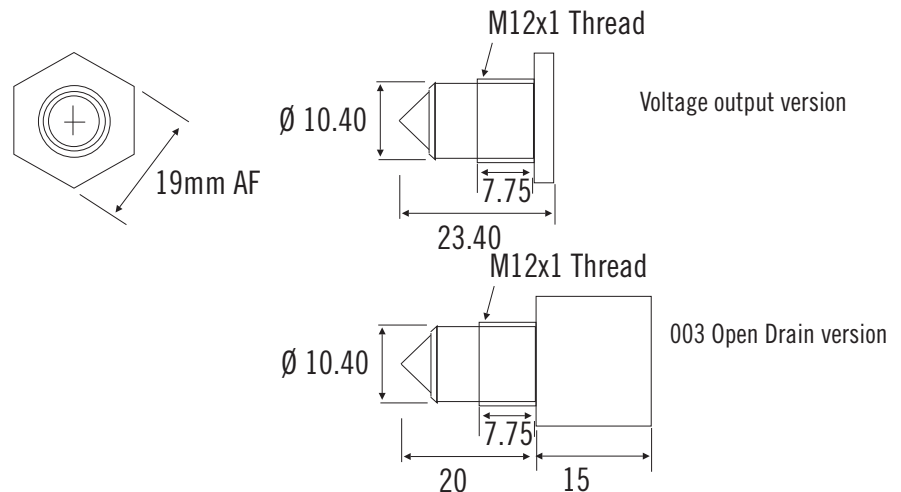

Cynergy3 Components Ltd.
7 Cobham Road
Ferndown Industrial Estate
Wimborne, Dorset BH21 7PE
Telephone +44 (0) 1202 897969
Email:sales@cynergy3.com

ISO9001 CERTIFIED

OLS2 2018



www.cynergy3.com

OLS2 Series

Optical liquid level sensor - External M12 mount

Installation

The sensor can be mounted in either the side or the bottom of a tank. It must not be mounted in the top of a tank with the cone downwards.

This sensor requires a hole of 12mm minimum or an M12x1 thread socket connection. The hole should be in a flat surface and be free of burrs.

The sensor with suitable gasket should be inserted into the hole and a fixing nut fitted on the M12 thread on the inside of the tank. Alternatively the sensor can be screwed into a M12x1 socket. The sensor should not be overtightened.

Cleaning

Proper fluids should be selected based on the type of contamination to be removed. It is recommended that freon or alcohol based solvents are used. DO NOT USE chlorinated solvents such as trichloroethylene as these are likely to attack the sensor housing material.

Liquid Media Compatibility

Check that the fluid in which you wish to use the sensor is compatible with Polysulfone.

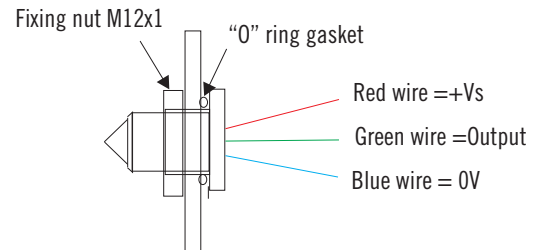

Note. LLPK1 - Nitrile 'O' ring and Nickel plated brass M12 nut kit - is available as an optional extra.

Electrical Connections

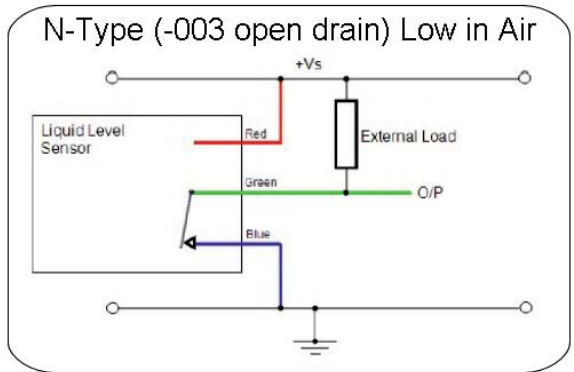
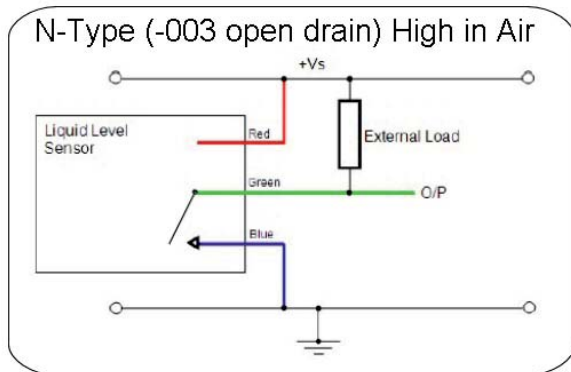
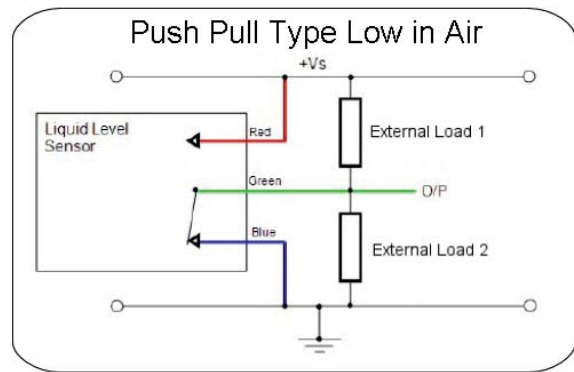
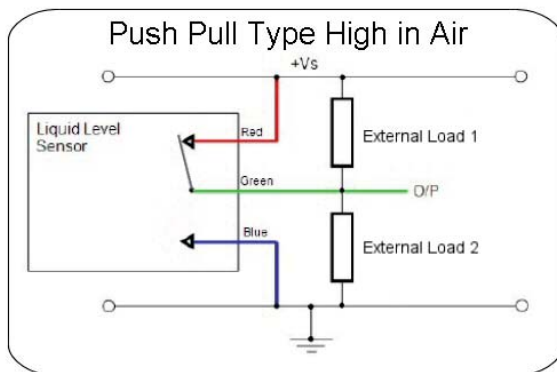

Cynergy3 Components Ltd.
7 Cobham Road
Ferndown Industrial Estate
Wimborne, Dorset BH21 7PE
Telephone +44 (0) 1202 897969
Email: sales@cynergy3.com

ISO9001 CERTIFIED

www.cynergy3.com