

# PRO-ELEC



**Model No. PEL01373**

**MAINTAINED  
LED BULKHEAD EMERGENCY LIGHT**

**Please read these instructions carefully before starting installation and retain for future reference.**

## **IMPORTANT SAFETY INFORMATION**

### **RISK OF ELECTRICAL SHOCK. ALWAYS ISOLATE THE POWER AT THE MAINS BEFORE INSTALLING OR MAINTAINING THIS EMERGENCY LIGHT.**

- This product must be installed by a competent person in accordance with the Building Regulations and the current edition of the IET Wiring Regulations (BS7671).
- This product is suitable for mounting on normally flammable surfaces such as wood, plasterboard or masonry.
- Emergency light fittings should have their own separate mains circuit, protected with an appropriate MCB or fuse. They should not share their supply with other lighting or electrical equipment.
- This product is suitable for connection to a 220-240V~ 50Hz, fixed wiring supply.
- For indoor or outdoor use. For installation outdoors, connect this luminaire to your wiring supply using rubberised cable (type H05RN-F), having three conductors each with a cross-sectional area of at least 1.00mm<sup>2</sup>.
- Ensure that after installation the equipment remains accessible for regular maintenance and testing.
- This product must be earthed.

## **INSTALLATION**

**NOTE:** Before drilling any holes, check that there are no hidden obstructions behind the mounting surface such as pipes or cables.

1. Remove the screws and lift off the diffuser and press the tabs outwards to release the LED housing. The LED housing will now pivot on its hinges.
2. The position of the cable entry and fixing holes are marked on the case. Remove and drill out as required.
3. Using the back of the product as a template, mark the position of the fixing holes on your mounting surface.
4. Fit a cable gland (not supplied) into the cable entry hole. Apply silicone sealant to the fixings if moisture or weatherproofing is required e.g. when installed outdoors.
5. Drill the fixing holes and fit wall plugs as appropriate and secure the back of the product to the mounting surface using suitable fixings (not supplied).
6. Make connection to the supply using the terminal block provided. Ensure that the correct polarities are observed i.e.:
  - Brown – Live terminal 'L'.
  - Blue – Neutral terminal 'N'.
  - Green/Yellow – Earth 'E'
  - Link wire 'L' to 'SW/L' can be removed to change between maintained and non-maintained.
7. Write the current date on the battery pack in the space provided.
8. Connect the battery to the socket on the PCB marked 'BATTERY'.
9. Refit the LED housing and diffuser making sure that it is securely screwed in place.
10. Turn on the power supply. The green LED should light to indicate that the battery is charging.
11. In maintained mode, the LEDs will illuminate.
12. Perform the electrical tests specified in the Wiring Regulations (BS7671).

**Test Record Sheet on reverse  
PULL OUT**

# Installation, maintenance a

Location:

Installation date:

Installed by:

		20__		20__		2
Month	Test	Sign	Date	Sign	Date	S
1	Short					
2	Short					
3	Short					
4	Short					
5	Short					
6	1 hr					
7	Short					
8	Short					
9	Short					
10	Short					
11	Short					
12	3hr					



**Test Record Sheet on reverse  
PULL OUT**

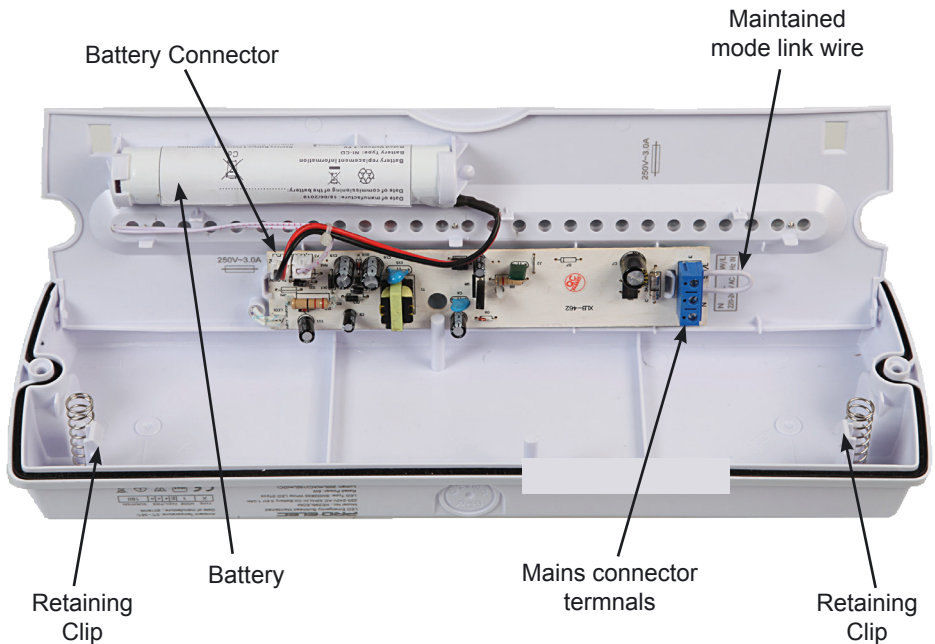

## OPERATIONAL CHECKS

**Note:** This equipment must be checked regularly in compliance with local regulation and codes of practice. For your own safety, testing should occur during the day.

- After installation, you should allow 24 hours for the battery pack to charge fully before testing.
- Isolate the power supply and check that the lamp remains illuminated for at least three hours. Restore the power supply.
- Each day: Check that the green charging LED is lit.
- Each month (short test): Isolate the power supply and check that the lamp remains illuminated. Record the results on the test record sheet included with these instructions.
- Every six months: Isolate the power supply and check that the lamp remains illuminated after 1 hour. Record the results on the included test record.
- Once each year: Isolate the power supply and check that the lamp is still illuminated after 3 hours. Record the results on the included test record.

**Please keep these test records in a safe place. A fire officer or other authorised person may want to see your record of inspection and testing.**

## CLEANING AND MAINTENANCE

- Clean the product with a soft, dry cloth only. Do not use any solvents or abrasive chemical cleaners.
- The LED lamps in this product are non-replaceable.

## Changing the battery

- If after a routine operation check, the lamp does not remain lit for the 3 hour period, a new battery pack may be required. Change the battery pack as follows:
  1. Isolate from the mains supply.
  2. Remove the diffuser and allow the LED plate to pivot to allow access to the PCB.
  3. Unplug the 2 pin battery pack connector.
  4. Remove the old battery pack.
  5. Write the current date on the new battery pack.
  6. Secure the new battery pack in position and connect the wiring terminal connector.
  7. Replace the LED plate and secure it and refit the diffuser making sure that it is securely screwed in place.
  8. Restore mains power and allow to charge for 24 hours.
  9. Perform the full operation check and update the test record.

## SPECIFICATIONS

Input voltage:	220-240V~ 50Hz
Rated power:	5W
Lamps:	SMD2835 LEDs, 27pcs x 0.06W
Luminous flux:	190Lm (AC) 160Lm (DC)
Continuous emergency illumination:	> 3 hours (when the battery is fully charged)
Battery pack:	Ni-Cd 3.6V 1.0Ah
Recharge time:	24 hours – approx.
Ambient temperature:	0 - 35°C
Over-discharge protection:	Yes
Ingress protection rating:	IP65



### INFORMATION ON WASTE DISPOSAL FOR CONSUMERS OF ELECTRICAL & ELECTRONIC EQUIPMENT.

When this product has reached the end of its life it must be treated as Waste Electrical & Electronic Equipment (WEEE). Any WEEE marked products must not be mixed with general household waste, but kept separate for the treatment, recovery and recycling of the materials used. Waste batteries can be returned to any waste battery recycling point which are provided by most battery retailers. Contact your local authority for details of battery and recycling schemes in your area.



Cd



Made in China. PR2 9PP

Man Rev 1.0