

Transistor, PNP TO-3

multicomp^{PRO}



Description:

Complementary silicon power transistors are designed for general-purpose switching and amplifier applications.

Features:

- DC current gain - $h_{FE} = 20 - 70$ at $I_C = 4A$ DC
- Collector-emitter saturation voltage- $V_{CE(sat)} = 1.1V$ DC (max.) at $I_C = 4A$ DC
- Excellent safe operating area
- Pb-free packages

Maximum Ratings

Rating	Symbol	Value	Unit
Collector-Emitter Voltage	V_{CEO}	60	V DC
Collector-Emitter Voltage	V_{CER}	70	
Collector-Base Voltage	V_{CB}	100	
Emitter-Base Voltage	V_{EB}	7	
Collector Current-Continuous	I_C	15	A DC
Base Current	I_B	7	
Total Power Dissipation at $T_C = 25^\circ C$ Derate above $25^\circ C$	P_D	115 0.657	W W/ $^\circ C$
Operating and Storage Junction Temperature Range	T_J, T_{Stg}	-65 to +200	$^\circ C$

Thermal Characteristics

Characteristic	Symbol	Max.	Unit
Thermal Resistance Junction to Case	$R_{\theta JC}$	1.52	$^\circ C/W$

Max. ratings are those values beyond which device damage can occur. Max. ratings applied to the device are individual stress limit values (not normal operating conditions) and are not valid simultaneously. If these limits are exceeded, device functional operation is not implied, damage may occur and reliability may be affected.

Transistor, PNP TO-3

multicomp **PRO**

Electrical Characteristics ($T_C = 25^\circ\text{C}$ unless otherwise noted)

Characteristic	Symbol	Min.	Max.	Unit
----------------	--------	------	------	------

Off Characteristics*

Collector-Emitter Sustaining Voltage (Note 1) ($I_C = 200\text{mA DC}$, $I_B = 0$)	$V_{EO(sus)}$	60	-	V DC
Collector-Emitter Sustaining Voltage (Note 1) ($I_C = 200\text{mA DC}$, $R_{BE} = 100\Omega$)	$V_{CER(sus)}$	70	-	
Collector Cut off Current ($V_{CE} = 30\text{V DC}$, $I_B = 0$)	I_{CEO}	-	0.7	mA DC
Collector Cut off Current ($V_{CE} = 100\text{V DC}$, $V_{BE(off)} = 1.5\text{V DC}$) ($V_{CE} = 100\text{V DC}$, $V_{BE(off)} = 1.5\text{V DC}$, $T_C = 150^\circ\text{C}$)	I_{CEX}	-	1 5	
Emitter Cut off Current ($V_{BE} = 7\text{V DC}$, $I_C = 0$)	I_{EBO}	-	5	

On Characteristic* (Note 1)

DC Current Gain ($I_C = 4\text{A DC}$, $V_{CE} = 4\text{mA DC}$) ($I_C = 10\text{A DC}$, $V_{CE} = 4\text{V DC}$)	h_{FE}	20 5	70 -	-
Collector-Emitter Saturation Voltage ($I_C = 4\text{A DC}$, $I_B = 400\text{A DC}$) ($I_C = 10\text{A DC}$, $I_B = 3.3\text{A DC}$)	$V_{CE(sat)}$	-	1.1 3	V DC
Base-Emitter On Voltage ($I_C = 4\text{A DC}$, $V_{CE} = 4\text{V DC}$)	$V_{BE(on)}$	-	1.5	

Second Breakdown

Second Breakdown Collector Current with Base Forward Biased ($V_{CE} = 40\text{V DC}$, $t = 1\text{s}$, Non Repetitive)	$I_{S/b}$	2.87	-	A DC
---	-----------	------	---	------

Dynamic Characteristics

Current-Gain - Bandwidth Product ($I_C = 0.5\text{A DC}$, $V_{CE} = 10\text{V DC}$, $f = 1\text{MHz}$)	f_T	2.5	-	MHz
*Small-Signal Current Gain ($I_C = 1\text{A DC}$, $V_{CE} = 4\text{V DC}$, $f = 1\text{kHz}$)	h_{fe}	15	120	pF
*Small-Signal Current Gain Cut off Frequency ($V_{CE} = 4\text{V DC}$, $I_C = 1\text{A DC}$, $f = 1\text{kHz}$)	f_{hfe}	10	-	kHz

*Indicates Within JEDEC Registration. (MJ2955).

1. Pulse Test : Pulse Width = $300\mu\text{s}$, Duty Cycle $\leq 2\%$.

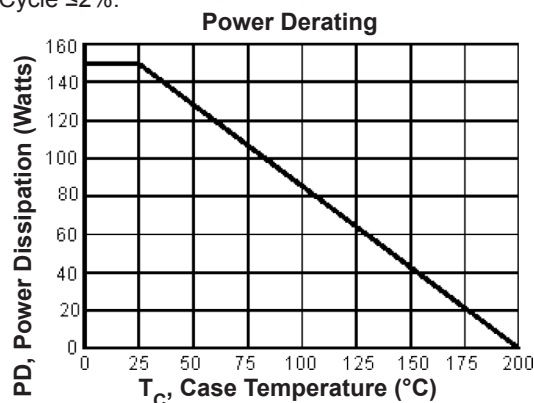

Newark.com/multicomp-pro
Farnell.com/multicomp-pro
Element14.com/multicomp-pro

multicomp **PRO**

Transistor, PNP TO-3

Active Region Safe Operating Area

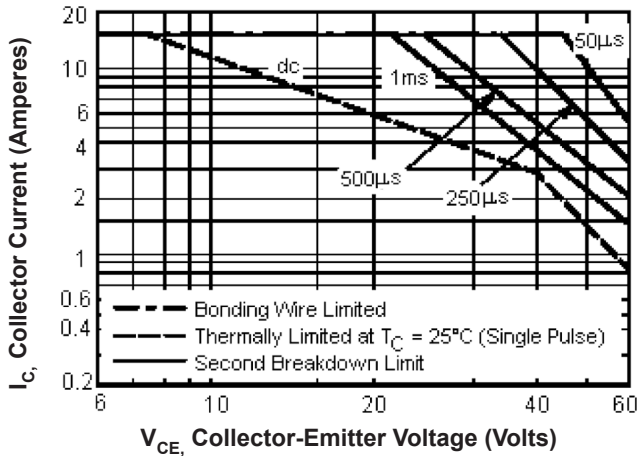

There are two limitation on the power handling ability of a transistor: average junction temperature and second breakdown. Safe operating area curves indicate $I_C - V_{CE}$ limits of the transistor that must be observed for reliable operation; i.e., the transistor must not be subjected to greater dissipation than curves indicate.

The data is based on $T_C = 25^\circ\text{C}$; $T_{J(pk)}$ is variable depending on power level. Second breakdown pulse limits are valid for duty cycles to 10% but must be derated for temperature according.

DC Current Gain

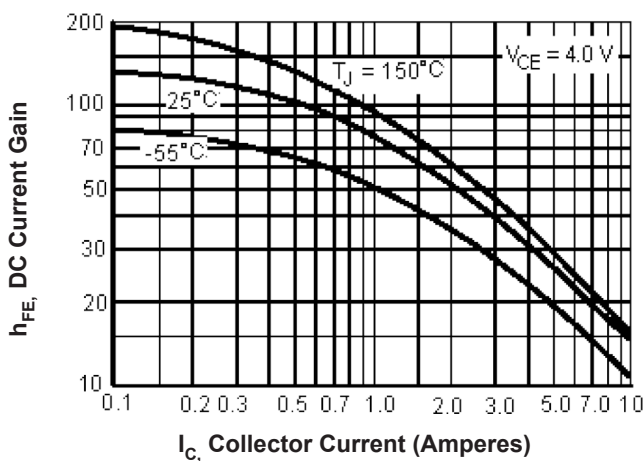

Collector Saturation Region

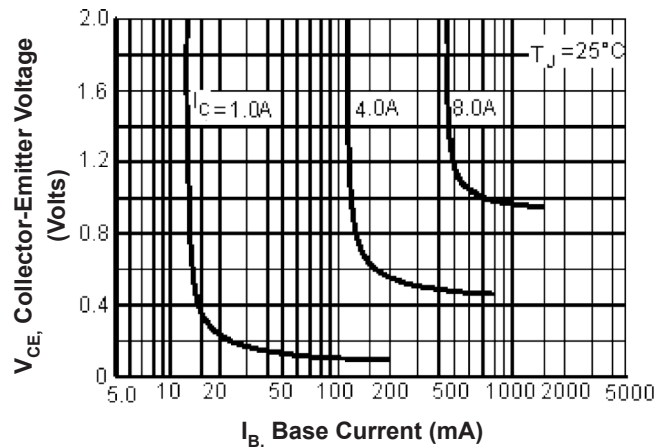

"On" Voltage

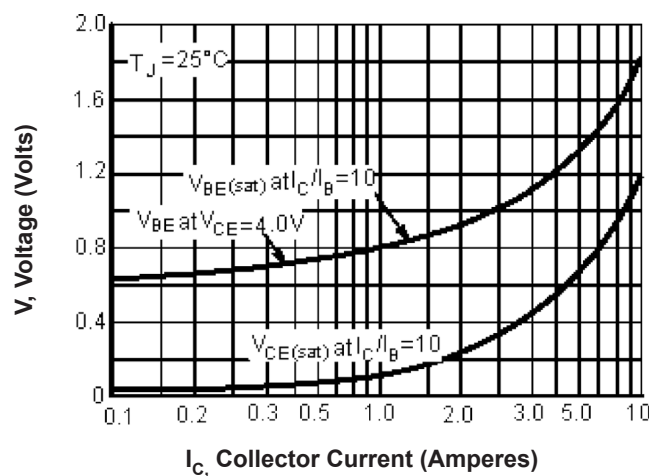

Transistor, PNP TO-3

Dimensions

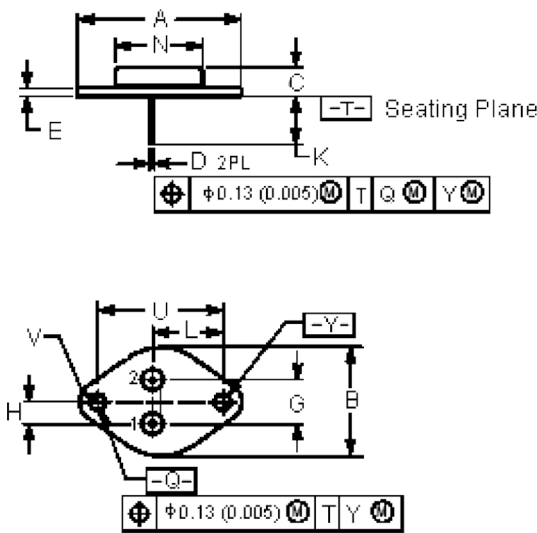

Dimensions	Min.	Max.
A	1.55 (39.37)	Reference
B	-	1.05 (26.67)
C	0.25 (6.35)	0.335 (8.51)
D	0.038 (0.97)	0.043 (1.09)
E	0.055 (1.4)	0.07 (1.77)
G	0.43 (10.92) BSC	
H	0.215 (5.46) BSC	
K	0.44 (11.18)	0.48 (12.19)
L	0.665 (16.89) BSC	
N	-	0.83 (21.08)
Q	0.151 (3.84)	0.165 (4.19)
U	1.187 (30.15) BSC	
V	0.131 (3.33)	0.188 (4.77)

Pin Configuration:

- Pin 1. Base
- 2. Emitter
- Collector (Case)

Dimensions : Inches (Millimetres)

Part Number Table

Description	Part Number
Transistor, PNP, TO-3	MJ2955

Important Notice : This data sheet and its contents (the "Information") belong to the members of the AVNET group of companies (the "Group") or are licensed to it. No licence is granted for the use of it other than for information purposes in connection with the products to which it relates. No licence of any intellectual property rights is granted. The Information is subject to change without notice and replaces all data sheets previously supplied. The Information supplied is believed to be accurate but the Group assumes no responsibility for its accuracy or completeness, any error in or omission from it or for any use made of it. Users of this data sheet should check for themselves the Information and the suitability of the products for their purpose and not make any assumptions based on information included or omitted. Liability for loss or damage resulting from any reliance on the Information or use of it (including liability resulting from negligence or where the Group was aware of the possibility of such loss or damage arising) is excluded. This will not operate to limit or restrict the Group's liability for death or personal injury resulting from its negligence. Multicomp Pro is the registered trademark of Premier Farnell Limited 2019.