



SYSTEM 12/25RS/DM

TILE REPLACEMENT

2' x 2' Tile Replacement System with Mounts for Strobes, WAP, WLAN, Indicator Light and Cameras



GENERAL DESCRIPTION

The **SYSTEM 12/25RS/DM** is a complete 2' x 2' tile replacement, shallow depth, lightweight, with built-in 1-gang and 4 Sq device mount to accommodate 3rd party strobes, wifi access points, WLAN, indicator lights and cameras. Easy cabling pass through to front device mount location. Components include: an 8" O.D. loudspeaker, 5-oz. magnet, with a 4W-25V rotary select transformer. Integral enclosure is 1,283 CID molded fiber. Grille is perforated steel with four (4) seismic tie-off points in a white powder coat finish.

INTENDED USE - Indoor Environment with Extra Device Mount

Installation	In a 2'x 2' or 2'x 4' wide ceiling tile grid
Program Material	Signal Tones, Voice and Background Music
Maximum Device Mount	Not to exceed 3 Lbs.

AUDIO SPECIFICATIONS

Average Sensitivity	92 dB SPL, 1W/1M
Loudspeaker Power Rating	12W RMS EIA 426A Standard
Maximum Power Rating	15W @ 8 Ohms
Calculated Output	98 dB-SPL 4W/1M
Magnet Type & Weight	BeFe Ceramic, 5 oz. Nominal
Frequency Response	65 Hz - 17 kHz EIA 426A Standard
Nominal Coverage Angle	100° Included Angle -6 dB / 2 kHz, Half space
Audio Connection	7" Leads
Unit Weight	6.35 Lbs

SYSTEM COMPONENTS

Loudspeaker	8C5PAX
Transformer	4W-25V : 5 Tap, Rotary Select (4W, 2W, 1W, 0.50W, 0.25W)

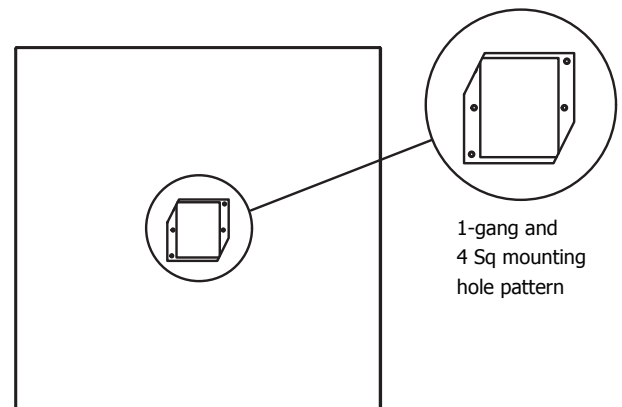
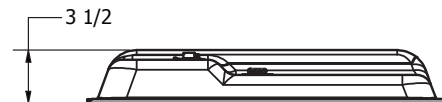
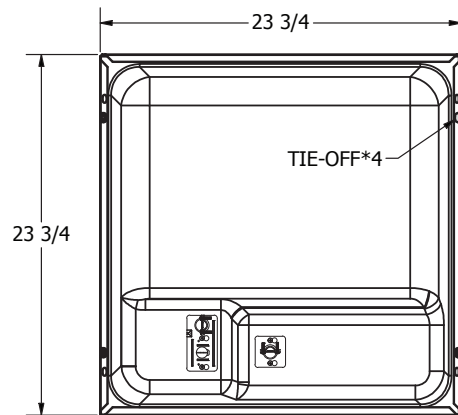

Recommended construction sequences, installation instructions, and A&E Specifications are available in various formats in the Specs and Diagrams section at: www.QuamSpeakers.com



QUAM NICHOLS COMPANY, INC.
 234 East Marquette Road. Chicago, IL. 60637
 t: 1-800-NEED-NOW (800-633-3669)
 f: 1-888-NEED-NOW (888-633-3669)
 e: NeedNow@QNC.com
www.QuamSpeakers.com