

# Temperature measuring transducer - MACX MCR-TS-I-OLP - 2908662

Please be informed that the data shown in this PDF Document is generated from our Online Catalog. Please find the complete data in the user's documentation. Our General Terms of Use for Downloads are valid (<http://phoenixcontact.com/download>)



Output loop-powered temperature transducer, two universal inputs for thermocouples, resistance and voltage sensor, HART communication, freely configurable, installable in Zone 2, SIL 2/3



## Key Commercial Data

Packing unit	1 pc
GTIN	 4 055626 355450
GTIN	4055626355450
Weight per Piece (excluding packing)	171.800 g
Custom tariff number	85437090
Country of origin	Germany

## Technical data

### Dimensions

Width	12.5 mm
Height	99 mm
Depth	114.5 mm

### Ambient conditions

Ambient temperature (operation)	-40 °C ... 85 °C
	-40 °C ... 70 °C (SIL active)
Ambient temperature (storage/transport)	-40 °C ... 100 °C
Maximum altitude	≤ 4000 m (Above sea level)
Permissible humidity (operation)	5 % ... 95 % (non-condensing)
Degree of protection	IP20

### Input data

Sensor types (RTD) that can be used	Pt, Ni, Cu sensors: 2, 3, 4-wire
-------------------------------------	----------------------------------

# Temperature measuring transducer - MACX MCR-TS-I-OLP - 2908662

## Technical data

### Input data

Sensor types that can be used (TC)	A, B, C, D, E, J, K, L, N, R, S, T, U
Linear resistance measuring range	10 Ω ... 2000 Ω (Minimum measuring span: 10 Ω)
Temperature measuring range	-250 °C ... 2500 °C (Range depending on the sensor type)
	-200 °C ... 850 °C (Pt 100)

### Output data

Configurable/programmable	no
Current output signal	4 mA ... 20 mA
	20 mA ... 4 mA
Max. output current	23 mA

### Power supply

Supply voltage range	12 V ... 42 V (Standard)
	12 V ... 32 V (SIL active)

### Connection data

Connection method	Screw connection
Stripping length	7 mm
Screw thread	M3
Conductor cross section solid	0.2 mm <sup>2</sup> ... 2.5 mm <sup>2</sup>
Conductor cross section flexible	0.2 mm <sup>2</sup> ... 2.5 mm <sup>2</sup>
Conductor cross section AWG	24 ... 14
Torque	0.5 Nm ... 0.6 Nm

### General

Overvoltage category	II
Degree of pollution	2
Color	gray
Conformance	CE-compliant
ATEX	# II 3G Ex nA IIC T6...T4 Gc
UL, USA/Canada	UL 61010 Recognized
FM approval	NI, Class I, Div. 2, Groups A, B, C, D
CSA	NI / Class I / Div. 2 / ABCD T6/T5/T4

### Standards and Regulations

Conformance	CE-compliant
ATEX	# II 3G Ex nA IIC T6...T4 Gc
UL, USA/Canada	UL 61010 Recognized
FM approval	NI, Class I, Div. 2, Groups A, B, C, D
CSA	NI / Class I / Div. 2 / ABCD T6/T5/T4

### Environmental Product Compliance

China RoHS	Environmentally friendly use period: unlimited = EFUP-e
------------	---

# Temperature measuring transducer - MACX MCR-TS-I-OLP - 2908662

Technical data

Environmental Product Compliance

	No hazardous substances above threshold values
--	--

Drawings

Block diagram

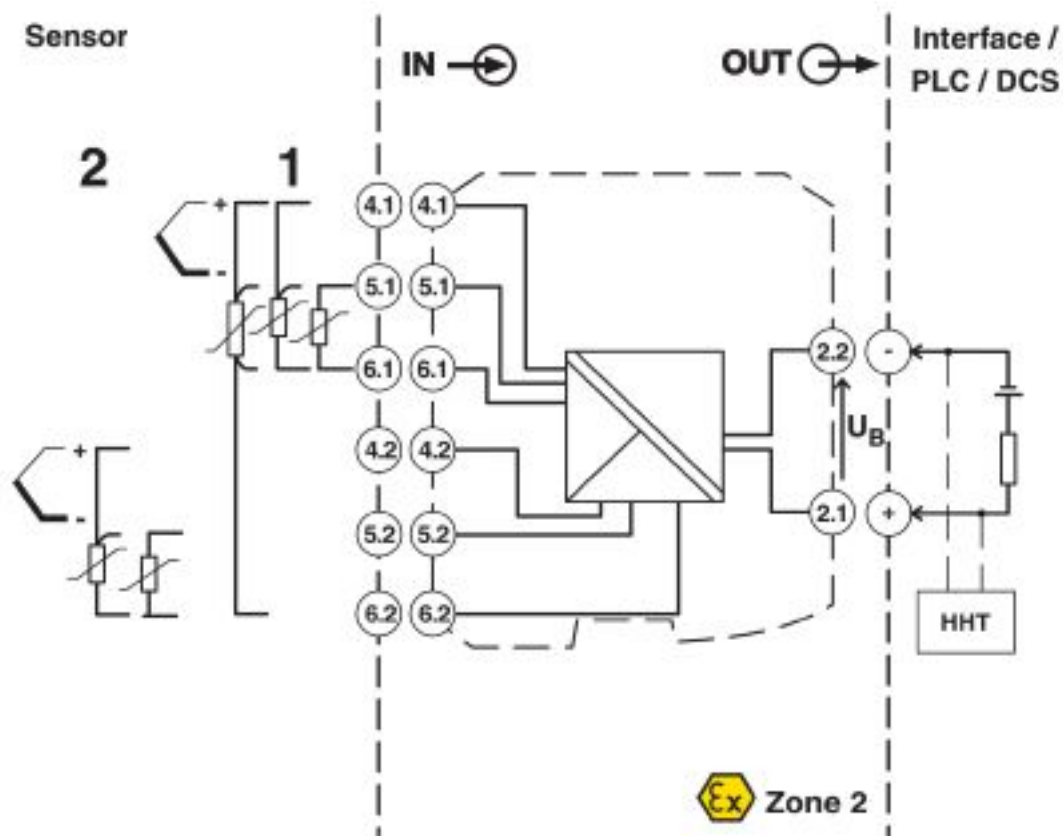

# Temperature measuring transducer - MACX MCR-TS-I-OLP - 2908662

Pictogram

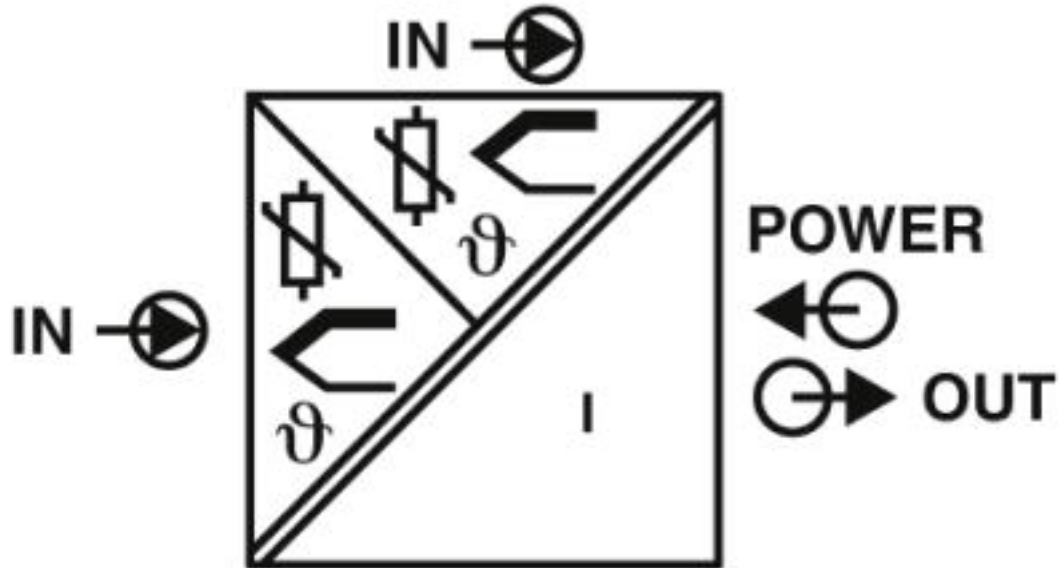

## Classifications

eCl@ss

eCl@ss 4.0	27200200
eCl@ss 4.1	27200200
eCl@ss 5.0	27200200
eCl@ss 5.1	27200200
eCl@ss 6.0	27200200
eCl@ss 7.0	27200206
eCl@ss 8.0	27200206
eCl@ss 9.0	27210129

ETIM

ETIM 2.0	EC001446
ETIM 3.0	EC001446
ETIM 4.0	EC001446
ETIM 5.0	EC001446
ETIM 6.0	EC002919
ETIM 7.0	EC002919

## Approvals

Approvals

Approvals

UL Recognized / cUL Recognized / Functional Safety / EAC / cULus Recognized

# Temperature measuring transducer - MACX MCR-TS-I-OLP - 2908662

## Approvals

Ex Approvals

ATEX / FM approved / CSA

### Approval details

UL Recognized		<a href="http://database.ul.com/cgi-bin/XYV/template/LISEXT/1FRAME/index.htm">http://database.ul.com/cgi-bin/XYV/template/LISEXT/1FRAME/index.htm</a>	FILE E 198586
---------------	--	---	---------------

cUL Recognized		<a href="http://database.ul.com/cgi-bin/XYV/template/LISEXT/1FRAME/index.htm">http://database.ul.com/cgi-bin/XYV/template/LISEXT/1FRAME/index.htm</a>	FILE E 198586
----------------	--	---	---------------

Functional Safety	<a href="http://www.tuev-sued.de">http://www.tuev-sued.de</a>	Z10 17 09 29429 006
-------------------	---	---------------------

EAC		RU C- DE.A*30.B.01082
-----	--	--------------------------

cULus Recognized		
------------------	--	--

## Accessories

### Accessories

#### Device marking

Plastic label - UC-EMLP (11X9) - 0819291



Plastic label, Sheet, white, unlabeled, can be labeled with: BLUEMARK ID COLOR, BLUEMARK ID, BLUEMARK CLED, PLOTMARK, CMS-P1-PLOTTER, mounting type: adhesive, lettering field size: 11 x 9 mm, Number of individual labels: 10

Plastic label - UC-EMLP (11X9) YE - 0822602



Plastic label, Sheet, yellow, unlabeled, can be labeled with: BLUEMARK ID COLOR, BLUEMARK ID, BLUEMARK CLED, PLOTMARK, CMS-P1-PLOTTER, mounting type: adhesive, lettering field size: 11 x 9 mm, Number of individual labels: 10

## Temperature measuring transducer - MACX MCR-TS-I-OLP - 2908662

### Accessories

#### Plastic label - UC-EMLP (11X9) SR - 0828094



Plastic label, Sheet, silver, unlabeled, can be labeled with: BLUEMARK ID COLOR, BLUEMARK ID, BLUEMARK CLED, PLOTMARK, CMS-P1-PLOTTER, mounting type: adhesive, lettering field size: 11 x 9 mm, Number of individual labels: 10

---

#### Plastic label - US-EMLP (11X9) - 0828789



Plastic label, Card, white, unlabeled, can be labeled with: BLUEMARK ID COLOR, BLUEMARK ID, THERMOMARK PRIME, THERMOMARK CARD 2.0, THERMOMARK CARD, mounting type: adhesive, lettering field size: 11 x 9 mm, Number of individual labels: 135

---

#### Plastic label - US-EMLP (11X9) YE - 0828871



Plastic label, Card, yellow, unlabeled, can be labeled with: BLUEMARK ID COLOR, BLUEMARK ID, THERMOMARK PRIME, THERMOMARK CARD 2.0, THERMOMARK CARD, mounting type: adhesive, lettering field size: 11 x 9 mm, Number of individual labels: 135

---

#### Plastic label - US-EMLP (11X9) SR - 0828872



Plastic label, Card, silver, unlabeled, can be labeled with: BLUEMARK ID COLOR, BLUEMARK ID, THERMOMARK PRIME, THERMOMARK CARD 2.0, THERMOMARK CARD, mounting type: adhesive, lettering field size: 11 x 9 mm, Number of individual labels: 135

---

#### Device marker - LS-EMLP (11X9) WH - 0831678



Device marker, Sheet, white, unlabeled, can be labeled with: TOPMARK NEO, TOPMARK LASER, mounting type: adhesive, lettering field size: 11 x 9 mm, Number of individual labels: 255

# Temperature measuring transducer - MACX MCR-TS-I-OLP - 2908662

## Accessories

Device marker - LS-EMLP (11X9) YE - 0831732

Device marker, Sheet, yellow, unlabeled, can be labeled with: TOPMARK NEO, TOPMARK LASER, mounting type: adhesive, lettering field size: 11 x 9 mm, Number of individual labels: 255



Device marker - LS-EMLP (11X9) SR - 0831705

Device marker, Sheet, silver, unlabeled, can be labeled with: TOPMARK NEO, TOPMARK LASER, mounting type: adhesive, lettering field size: 11 x 9 mm, Number of individual labels: 255



## Insulating sleeve

Insulating sleeve - MPS-IH BK - 0201731

Insulating sleeve, color: black



Insulating sleeve - MPS-IH GY - 0201728

Insulating sleeve, color: gray



Insulating sleeve - MPS-IH GN - 0201702

Insulating sleeve, color: green



# Temperature measuring transducer - MACX MCR-TS-I-OLP - 2908662

## Accessories

Insulating sleeve - MPS-IH YE - 0201692

Insulating sleeve, color: yellow



Insulating sleeve - MPS-IH BU - 0201689

Insulating sleeve, color: blue



Insulating sleeve - MPS-IH RD - 0201676

Insulating sleeve, color: red



Insulating sleeve - MPS-IH WH - 0201663

Insulating sleeve, color: white



## Labeled device marker

Plastic label - UC-EMLP (11X9) CUS - 0824547

Plastic label, can be ordered: by sheet, white, labeled according to customer specifications, mounting type: adhesive, lettering field size: 11 x 9 mm





# Temperature measuring transducer - MACX MCR-TS-I-OLP - 2908662

## Accessories

Plastic label - UC-EMLP (11X9) YE CUS - 0824548



Plastic label, can be ordered: by sheet, yellow, labeled according to customer specifications, mounting type: adhesive, lettering field size: 11 x 9 mm

Plastic label - UC-EMLP (11X9) SR CUS - 0828098



Plastic label, can be ordered: by sheet, silver, labeled according to customer specifications, mounting type: adhesive, lettering field size: 11 x 9 mm, Number of individual labels: 10

## Programming adapter

Programming adapter - MCR-PAC-T-USB - 2309000



Programming adapter with USB and T port interface, 2.4 m for programming FA MCR-..., MCR-...-LP-..., and MCR-...-HT-... modules

## Programming cable

Cable adapter - GW HART USB MODEM - 1003824



USB HART modem cable for communication between a PC and HART devices, cable length: 1m.

## Test plug terminal block

Test plugs - MPS-MT - 0201744



Test plugs, with solder connection up to 1 mm<sup>2</sup> conductor cross section, color: gray

