

CIPOS™ Micro 600V / 3A

IM240-S6Z1B / IM240-S6Y1B / IM240-S6Y2B

Description

IM240-M6 Series are 3-phase Intelligent Power Modules (IPM) designed for advanced appliance motor drive applications such as energy efficient fans and pumps. These advanced IPMs offers a combination of low $V_{CE(sat)}$ RC-DF IGBT technology and the industry benchmark half-bridge high voltage, rugged driver in a familiar package.

Features

- 600V 3-phase inverter including gate drivers & bootstrap function
- Low 2.1V $V_{CE(sat)}$ (typ, 25°C, 2.5A) RC-DF IGBT
- UL Certified Temperature Sense (NTC)
- Advanced input filter with shoot-through protection
- Optimized dV/dt for loss and EMI trade offs
- Open-emitter for single and leg-shunt current sensing
- 3.3V logic compatible
- Driver tolerant to negative voltage (-VS)
- Undervoltage lockout for all channels
- Isolation 1900VRMS, 1min

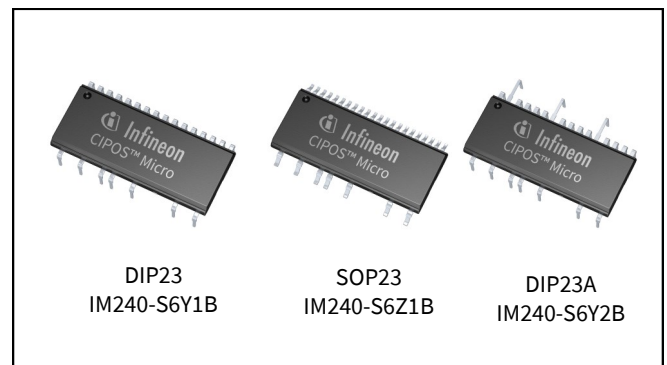

Potential Applications

- Air-conditioner fans
- Refrigerator compressors
- Ventilation fans & blower fans
- Low power motor drives

Product validation

Qualified for industrial applications according to the relevant tests of JEDEC47/20/22.

Table1 Part Ordering Table

Base part number	Package Type	Standard Pack		Orderable Part Number
		Form	Quantity	
IM240-S6 Series	DIP23	Tube	240	IM240-S6Y1B
	DIP23A	Tube	240	IM240-S6Y2B
	SOP23	Tube	240	IM240-S6Z1B

Table of Contents

Table of Contents

Description1

Features1

Potential Applications1

Product validation1

Table of Contents2

1 Internal Electrical Schematic3

2 Pin Configuration4

2.1 Pin Assignment4

2.2 Pin Descriptions5

3 Absolute Maximum Rating7

3.1 Module7

3.2 Inverter7

3.3 Control7

4 Thermal Characteristics8

5 Recommended Operating Conditions9

6 Static Parameters 10

6.1 Inverter 10

6.2 Control10

7 Dynamic Parameters11

7.1 Inverter11

7.2 Control11

8 Thermistor Characteristics12

9 Mechanical Characteristics and Ratings13

10 Qualification Information14

11 Diagrams & Tables15

11.1 T_c Measurement Point15

11.2 Backside Curvature Measurement Points15

11.3 Input-Output Logic Table16

11.4 Switching Time Definitions17

12 Application Notes18

12.1 Typical Application Schematic18

12.2 Performance Charts18

12.3 T_J vs T_{TH}19

12.4 -V_S Immunity19

13 Package Outline20

12.1 SOP2320

12.2 DIP23A21

12.3 DIP2322

Revision History23

1 Internal Electrical Schematic

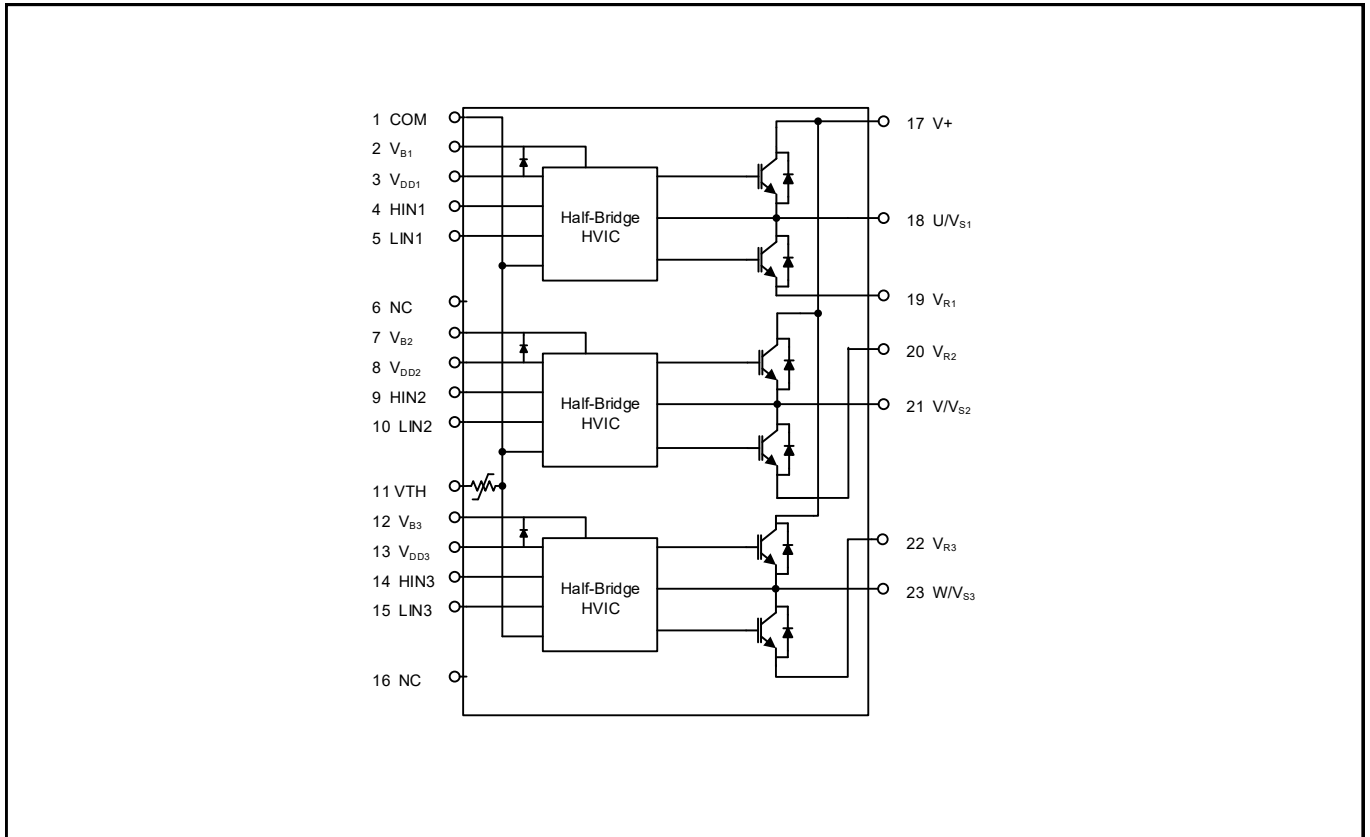

Figure 1 Internal electrical schematic

2 Pin Configuration

2.1 Pin Assignment

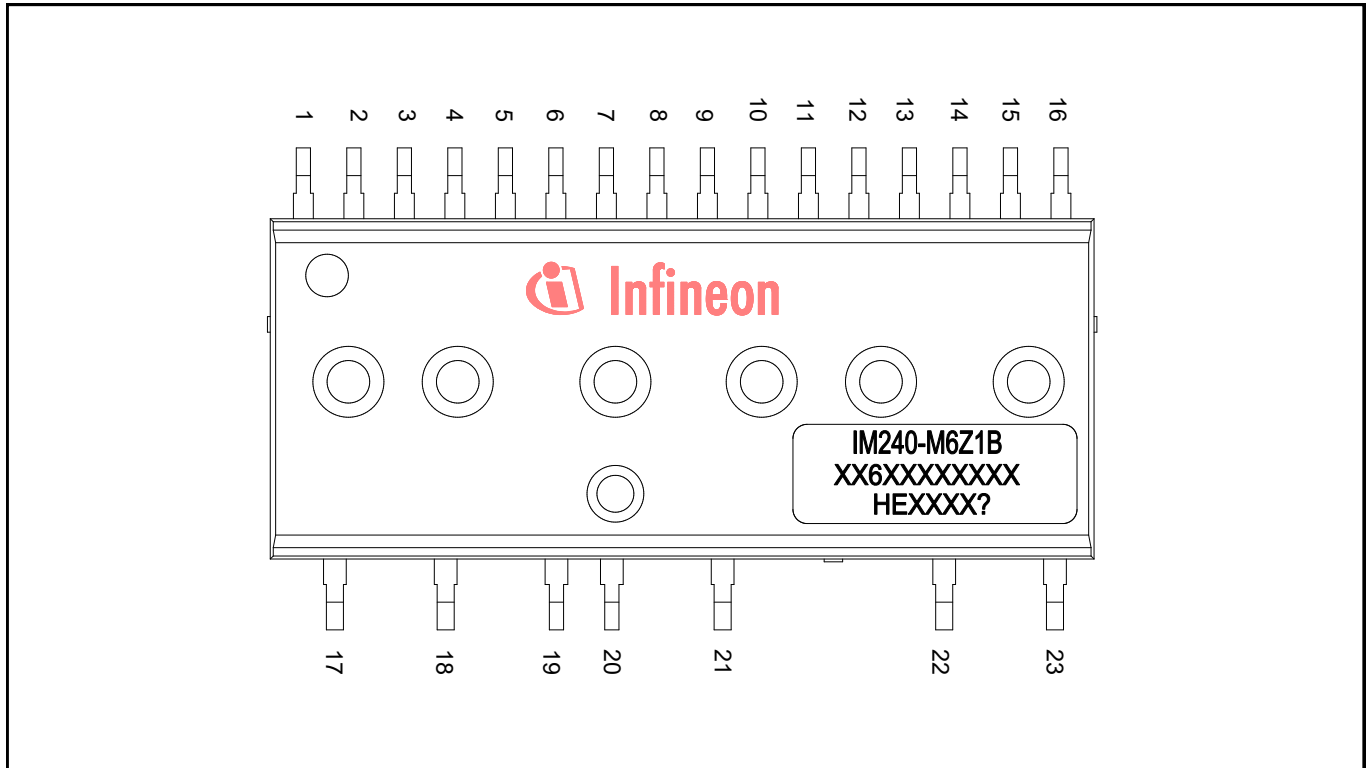

Figure 2 Module pinout

Table 2 Pin Assignment

Pin	Name	Description
1	COM	Logic ground
2	V _{B1}	High side floating supply voltage 1
3	V _{DD1}	Low side control supply 1
4	HIN1	Logic Input for High Side Gate Driver - Phase 1
5	LIN1	Logic Input for Low Side Gate Driver - Phase 1
6	NC	Not connected
7	V _{B2}	High side floating supply voltage 2
8	V _{DD2}	Low side control supply 2
9	HIN2	Logic Input for High Side Gate Driver - Phase 2
10	LIN2	Logic Input for Low Side Gate Driver - Phase 2
11	VTH	Thermistor output
12	V _{B3}	High side floating supply voltage 3
13	V _{DD3}	Low side control supply 3
14	HIN3	Logic Input for High Side Gate Driver - Phase 3
15	LIN3	Logic Input for Low Side Gate Driver - Phase 3

Pin Configuration

Pin	Name	Description
16	NC	Not connected
17	V+	Dc bus voltage positive
18	U/V _{S1}	Output- phase 1, high side floating supply offset 1
19	V _{R1}	Phase 1 low side emitter
20	V _{R2}	Phase 2 low side emitter
21	V/V _{S2}	Output- phase 2, high side floating supply offset 2
22	V _{R3}	Phase 3 low side emitter
23	W/V _{S3}	Output- phase 3, high side floating supply offset 3

2.2 Pin Descriptions

HIN(1,2,3) and LIN(1,2,3) (Low side and high side control pins)

These pins are positive logic and they are responsible for the control of the integrated IGBT. The Schmitt-trigger input thresholds of them are such to guarantee LSTTL and CMOS compatibility down to 3.3V controller outputs. Pull-down resistor of about 800kΩ is internally provided to pre-bias inputs during supply start-up and an ESD diode is provided for pin protection purposes. Input Schmitt-trigger and noise filter provide beneficial noise rejection to short input pulses.

The noise filter suppresses control pulses which are below the filter time T_{FILIN} . The filter acts according to Figure 4.

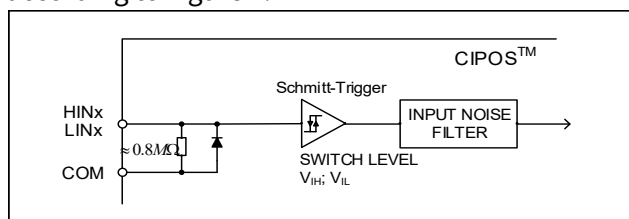

Figure 3 Input pin structure

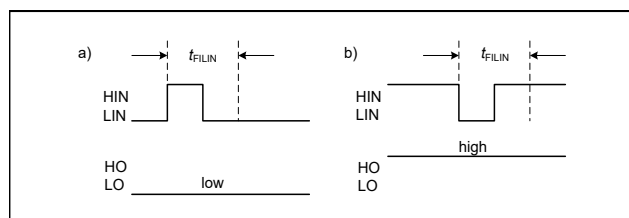

Figure 4 Input filter timing diagram

The integrated gate drive provides additionally a shoot through prevention capability which avoids the simultaneous on-state of the high-side and low-side switch of the same inverter phase. A minimum dead time insertion of typically 300ns is also provided by driver IC, in order to reduce cross-conduction of the external power switches.

V_{DD,COM} (Low side control supply and reference)

V_{DD} is the control supply and it provides power both to input logic and to output power stage. Input logic is referenced to COM ground.

The under-voltage circuit enables the device to operate at power on when a supply voltage of at least a typical voltage of V_{DDUV+} = 11.1V is present.

The IC shuts down all the gate drivers power outputs, when the VDD supply voltage is below V_{DDUV-} = 10.9V. This prevents the external power switches from critically low gate voltage levels during on-state and therefore from excessive power dissipation.

V_{B(1,2,3)} and V_{S(1,2,3)} (High side supplies)

V_B to V_S is the high side supply voltage. The high side circuit can float with respect to COM following the external high side power device emitter voltage.

Due to the low power consumption, the floating driver stage is supplied by integrated bootstrap circuit.

The under-voltage detection operates with a rising supply threshold of typical V_{BSUV+} = 11.1V and a falling threshold of V_{BSUV-} = 10.9V.

V_{S(1,2,3)} provide a high robustness against negative voltage in respect of COM. This ensures very stable designs even under rough conditions.

V_{R(1,2,3)} (Low side emitters)

The low side emitters are available for current measurements of each phase leg. It is recommended to keep the connection to pin COM as short as possible in order to avoid unnecessary inductive voltage drops.

Pin Configuration**VTH (Thermistor output)**

A UL certified NTC is integrated in the module with one terminal of the chip connected to COM and the other to VTH. When pulled up to a rail voltage such as VDD or 3.3V by a resistor, the VTH pin provides an analog voltage signal corresponding to the temperature of the thermistor.

U/V_{S1}, V/V_{S2}, W/V_{S3} (High side emitter and low side collector)

These pins are motor U, V, W input pins.

V+ (Positive bus input voltage, Pin 23)

The high side IGBTs are connected to the bus voltage. It is noted that the bus voltage does not exceed 450V.

Absolute Maximum Rating

3 Absolute Maximum Rating

3.1 Module

Table 3

Parameter	Symbol	Conditions		Units
Storage temperature	T_{STG}		-40 ~ 150	°C
Operating case temperature	T_C		-40 ~ 125	°C
Operating junction temperature	T_J		-40 ~ 150	°C
Isolation test voltage	V_{ISO}	1min, RMS, f = 60Hz	1900	V

3.2 Inverter

Table 4

Parameter	Symbol	Conditions		Units
Max. blocking voltage	V_{CES}/V_{RRM}		600	V
Output current	I_O	$T_C = 25^\circ\text{C}$	3	A
Peak output current	I_{OP}	$T_C = 25^\circ\text{C}, t_p < 1\text{ms}$	6	A
Peak power dissipation per IGBT	P_{tot}	$T_C = 25^\circ\text{C}$	8.4	W
Short circuit withstand time	T_{SC}	$V_{DC} = 400\text{V}, T_J = 150^\circ\text{C}, V_{DD} = 15\text{V}$	5	μs

3.3 Control

Table 5

Parameter	Symbol	Conditions		Units
Low side control supply voltage	V_{DD}		-3 ~ 20	V
Input voltage LIN, HIN	V_{IN}		-0.3 ~ V_{DD}	V
High side floating supply voltage (V_B reference to V_S)	V_{BS}		-0.3 ~ 20	V

4 Thermal Characteristics

Table 6

Parameter	Symbol	Conditions	Min.	Typ.	Max.	Units
Single IGBT thermal resistance, junction-case	$R_{TH(J-C)}$	Low side V-phase IGBT (See Figure 6 for T_C measurement point)	-	10.1	13.1	°C/W
Single diode thermal resistance, junction-case	$R_{TH(J-C)D}$	Low side V-phase diode (See Figure 6 for T_C measurement point)	-	11.5	14.9	°C/W

5 Recommended Operating Conditions

Table 7

Parameter	Symbol	Min.	Typ.	Max.	Units
Positive DC bus input voltage	V+	-	-	450	V
Low side control supply voltage	V _{DD}	13.5	-	16.5	V
High side floating supply voltage	V _{BS}	12.5	-	17.5	V
Input voltage	V _{IN}	0	-	5	V
PWM carrier frequency	F _{PWM}	-	20	-	kHz
External dead time between HIN & LIN	DT	1	-	-	μs
Voltage between COM and V _{R(1,2,3)}	V _{COMR}	-5	-	5	V
Minimum input pulse width	PW _{IN(ON)} , PW _{IN(OFF)}	0.5	-	-	μs

6 Static Parameters

6.1 Inverter

$(V_{DD-COM}) = (V_B - V_S) = 15\text{ V}$. $T_C = 25^\circ\text{C}$ unless otherwise specified.

Table 8

Parameter	Symbol	Conditions	Min.	Typ.	Max.	Units
Collector-to-emitter saturation voltage	$V_{CE(sat)}$	$I_C = 1\text{A}$	-	1.54	-	V
		$I_C = 2.5\text{A}$	-	2.2	2.7	V
		$I_C = 2.5\text{A}, T_J = 150^\circ\text{C}$	-	2.3	-	V
Collector emitter leakage current	I_{CES}	$V_{IN} = 0\text{V}, V_+ = 600\text{V}$	-	-	40	μA
Diode forward voltage drop	V_F	$I_C = 1\text{A}$	-	1.53	-	V
		$I_C = 2.5\text{A}$	-	2.10	2.6	V
		$I_C = 2.5\text{A}, T_J = 150^\circ\text{C}$	-	2.05	-	V

6.2 Control

$(V_{DD-COM}) = (V_B - V_S) = 15\text{ V}$. $T_C = 25^\circ\text{C}$ unless otherwise specified. The V_{IN} and I_{IN} parameters are referenced to COM and are applicable to all six channels. The V_{DDUV} parameters are referenced to COM. The V_{BSUV} parameters are referenced to VS.

Table 9

Parameter	Symbol	Min.	Typ.	Max.	Units
Logic "1" input voltage (LIN, HIN)	$V_{IN,TH+}$	2.2	-	-	V
Logic "0" input voltage (LIN, HIN)	$V_{IN,TH-}$	-	-	0.8	V
V_{DD}/V_{BS} supply undervoltage, positive going threshold	$V_{DD,UV+}, V_{BS,UV+}$	10.0	11.1	12.2	V
V_{DD}/V_{BS} supply undervoltage, negative going threshold	$V_{DD,UV-}, V_{BS,UV-}$	9.8	10.9	12.0	V
V_{DD}/V_{BS} supply undervoltage lock-out hysteresis	V_{DDUVH}, V_{BSUVH}	-	0.2	-	V
Quiescent V_{BS} supply current	I_{QBS}	-	-	70	μA
Quiescent V_{DD} supply current per channel	I_{QCC}	-	-	3.0	mA
Input bias current $V_{IN} = 5\text{V}$ for LIN, HIN	I_{IN+}	-	5	20	μA
Bootstrap resistance	R_{BS}	-	240	-	Ω

7 Dynamic Parameters

7.1 Inverter

$(V_{DD-COM}) = (V_B - V_S) = 15 \text{ V}$. $T_C = 25^\circ\text{C}$ unless otherwise specified

Table 10

Parameter	Symbol	Conditions	Min.	Typ.	Max.	Units
Input to output turn-on propagation delay	T_{ON}	$I_C = 1\text{A}$, $V_+ = 300\text{V}$	-	690	-	ns
Turn-on rise time	T_R		-	23	-	ns
Turn-on switching time	$T_{C(on)}$		-	132	-	ns
Input to output turn-off propagation delay	T_{OFF}	$I_C = 1\text{A}$, $V_+ = 300\text{V}$	-	770	-	ns
Turn-off fall time	T_F		-	101	-	ns
Turn-off switching time	$T_{C(off)}$		-	83	-	ns
Turn-on switching energy	E_{ON}	$I_C = 1\text{A}$, $V_+ = 300\text{V}$, $V_{DD} = 15\text{V}$, $L = 7\text{mH}$	-	37	-	μJ
Turn-off switching energy	E_{OFF}		-	8.3	-	
Diode reverse recovery energy	E_{REC}		-	7.6	-	
Diode reverse recovery time	T_{RR}		-	41	-	ns
Turn-on switching energy	E_{ON}	$I_C = 1\text{A}$, $V_+ = 300\text{V}$, $V_{DD} = 15\text{V}$, $L = 7\text{mH}$, $T_J = 150^\circ\text{C}$	-	62	-	μJ
Turn-off switching energy	E_{OFF}		-	17.6	-	
Diode reverse recovery energy	E_{REC}		-	19.0	-	
Diode reverse recovery time	T_{RR}		-	146	-	ns

7.2 Control

$(V_{DD-COM}) = (V_B - V_S) = 15 \text{ V}$. $T_C = 25^\circ\text{C}$ unless otherwise specified.

Table 11

Parameter	Symbol	Conditions	Min.	Typ.	Max.	Units
Input filter time (HIN, LIN)	$T_{FIL,IN}$	$V_{IN} = 0$ or $V_{IN} = 5\text{V}$	-	300	-	ns
Internal dead time	DT_{IC}	$V_{IN} = 0$ or $V_{IN} = 5\text{V}$	-	300	-	ns
Matching propagation delay time (on and off) for same phase high-side and low-side	M_T	External dead time > 500ns	-	-	50	ns

8 Thermistor Characteristics

Table 12

Parameter	Symbol	Conditions	Min.	Typ.	Max.	Units
Resistance	R_{25}	$T_c = 25^\circ\text{C}$, $\pm 5\%$ tolerance	44.65	47	49.35	$\text{k}\Omega$
Resistance	R_{125}	$T_c = 125^\circ\text{C}$	1.27	1.39	1.51	$\text{k}\Omega$
B-constant (25/100)	B	$\pm 1\%$ tolerance	-	4006	-	K
Temperature Range			-40	-	125	$^\circ\text{C}$

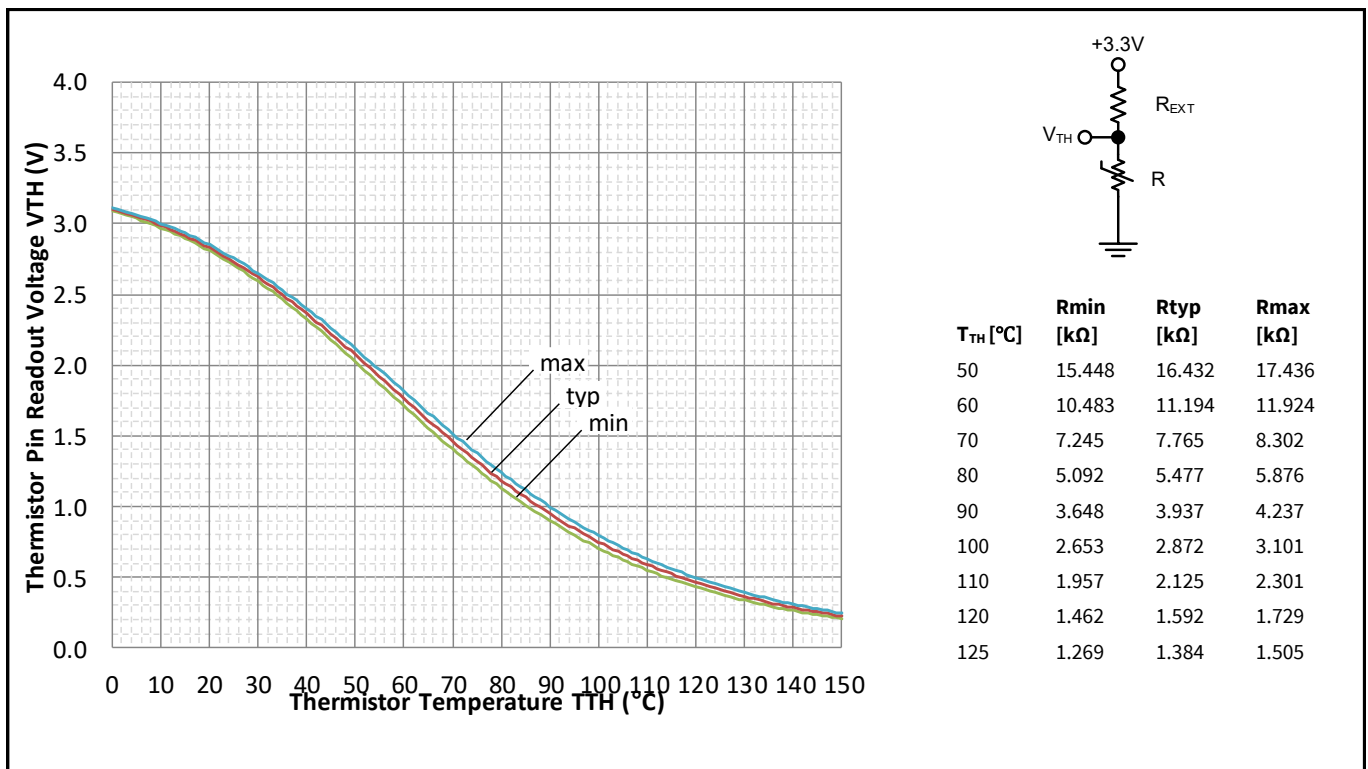

Figure 5 Thermistor resistance - temperature curve, for $R_{EXT}=9.76\text{k}\Omega$, and thermistor resistance variation with temperature.

9 Mechanical Characteristics and Ratings

Table 13

Parameter	Symbol	Conditions	Min.	Typ.	Max.	Units
Comparative Tracking Index	CTI		550	-	-	V
Curvature of module backside	BC	See Figure 6	-50	-	100	μm
Weight	W		-	3.1	-	g

10 Qualification Information

Table 14

UL Certified	File Number E252584 (pending)	
Moisture Sensitivity Level (SOP23 only)	MSL3	
RoHS Compliant	Yes	
ESD	Human Body Model	Class 2
	Charge discharge Model	Class C3

11 Diagram & Tables

11.1 Tc Measurement Point

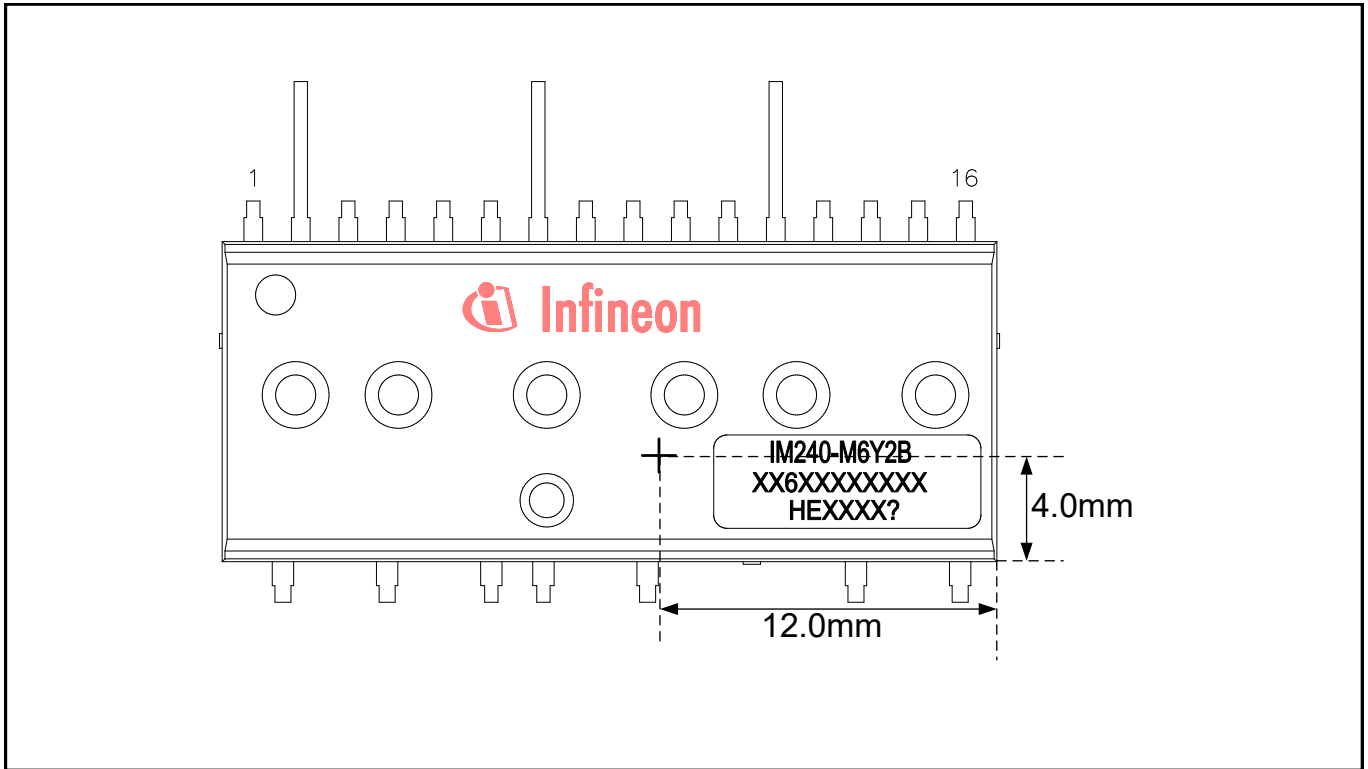

Figure 6 TC measurement point

11.2 Backside Curvature Measurements Points

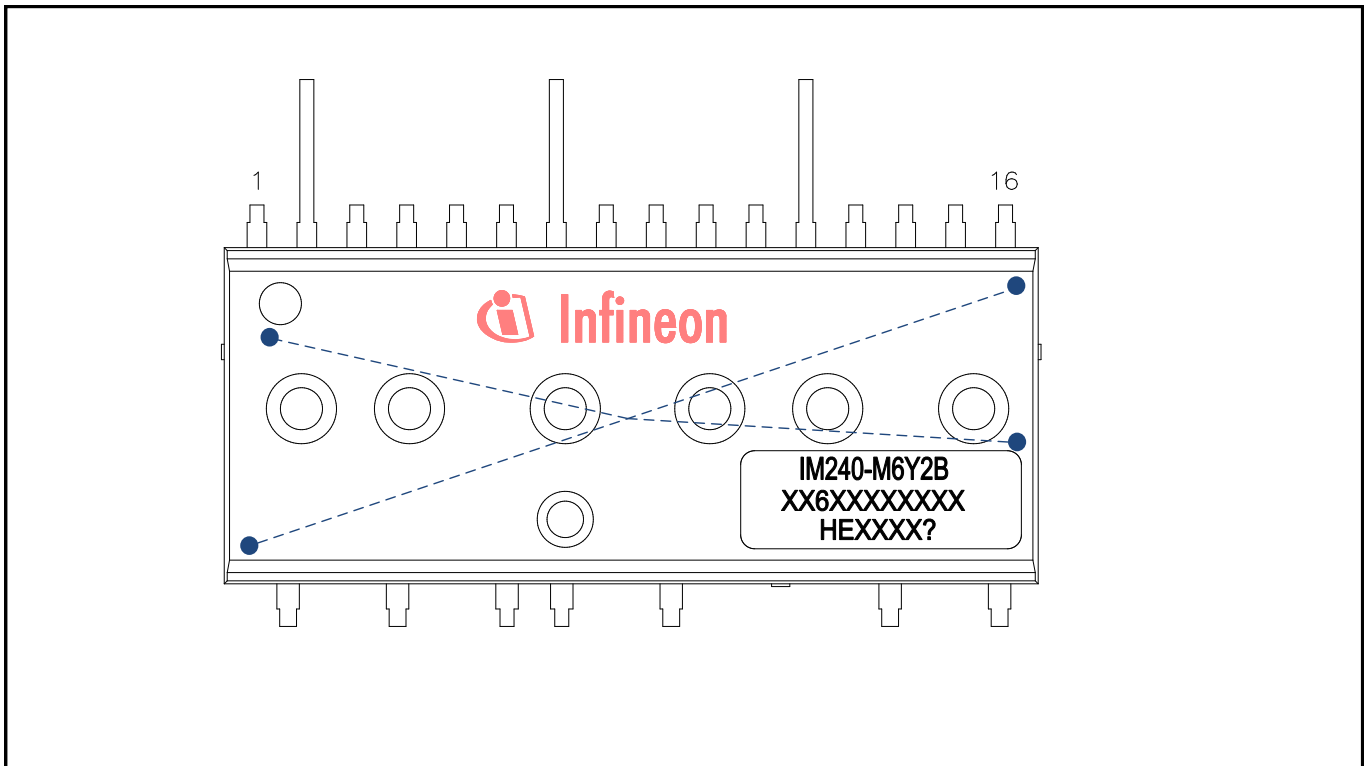

Figure 7 Curvature measurement points

11.3 Input-Output Logic Table

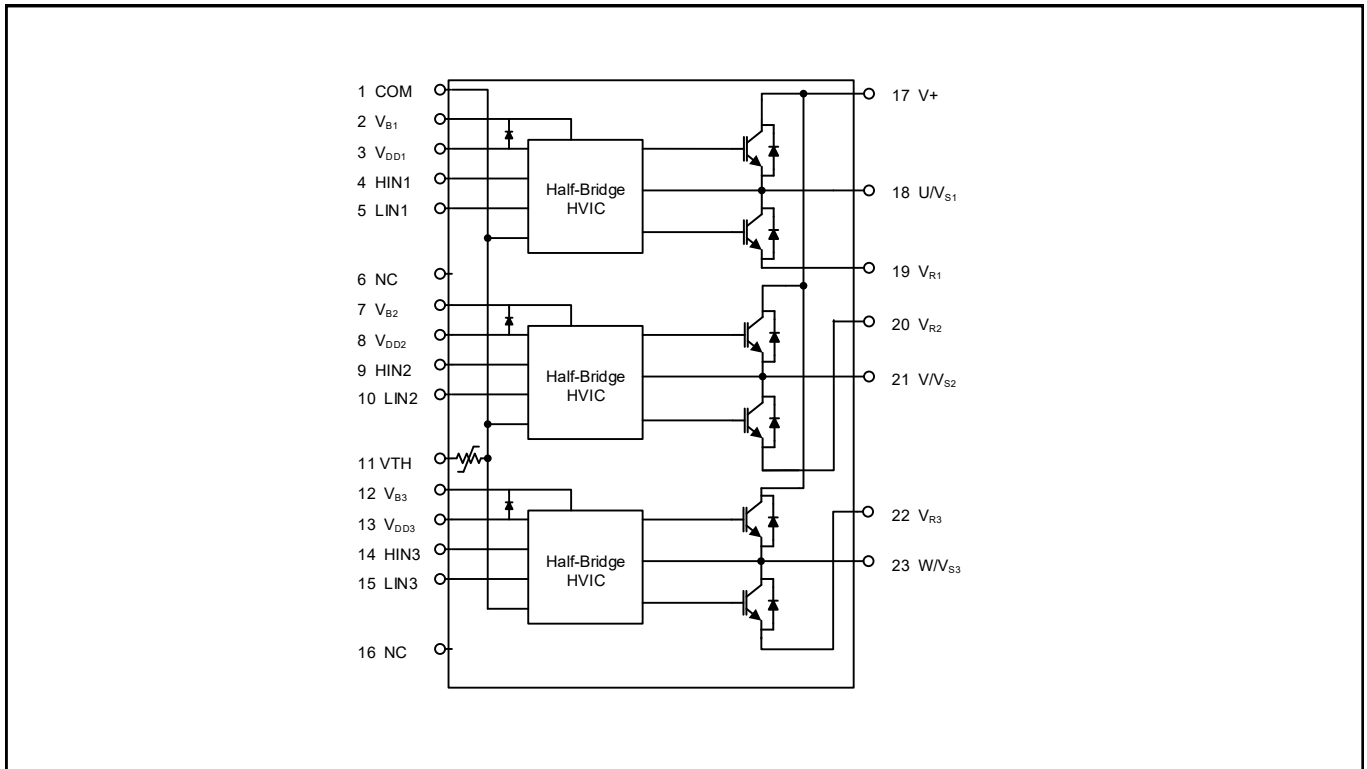

Figure 8 Module block diagram

Table 15

HIN 1,2,3	LIN 1,2,3	U,V,W
1	0	V ⁺
0	1	0
0	0	‡
1	1	‡

‡ Voltage depends on direction of phase current

11.4 Switching Time Definitions

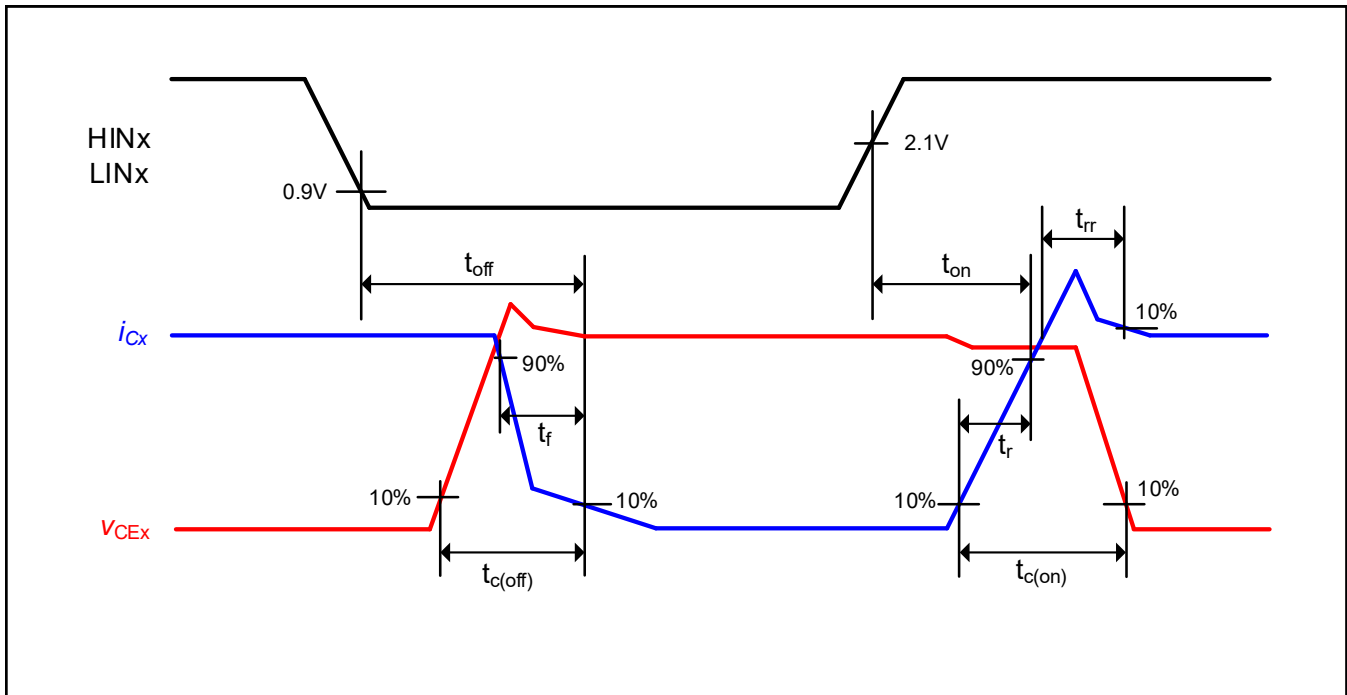

Figure 9 Switching times definition

12 Application Guide

12.1 Typical Application Schematic

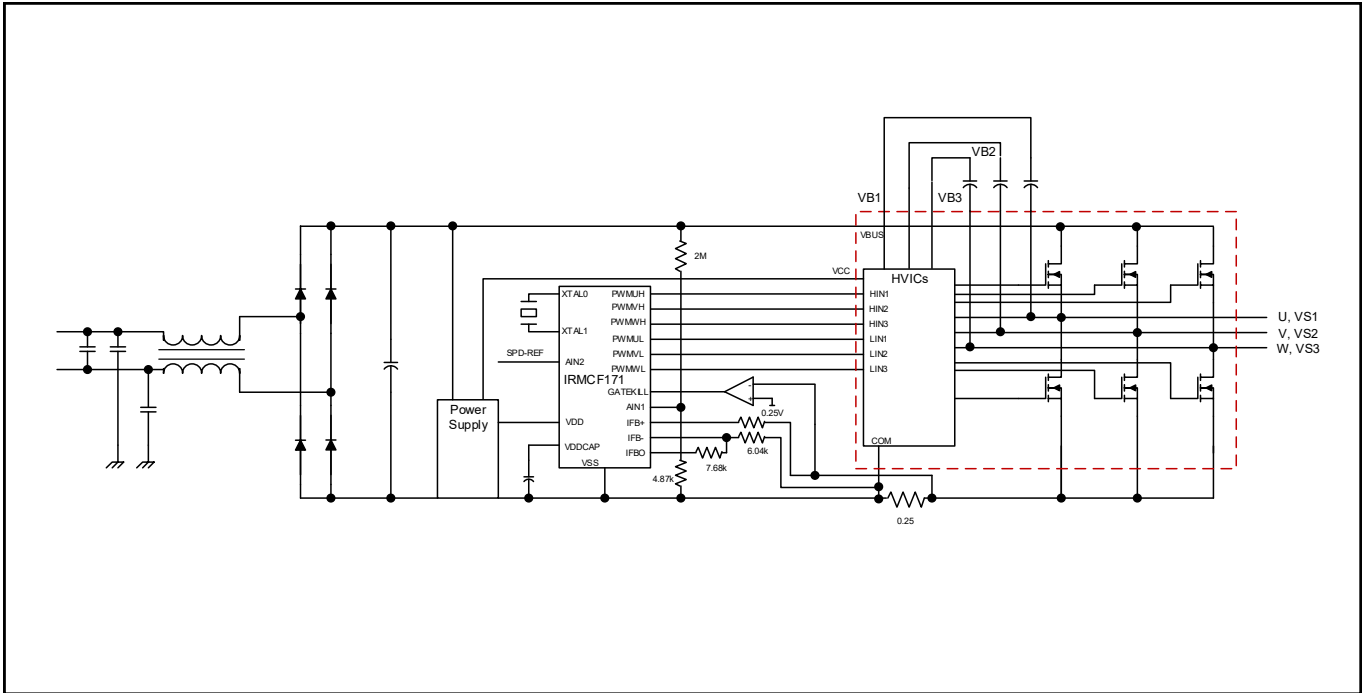

Figure 10 Application Schematic

12.2 Performance Charts

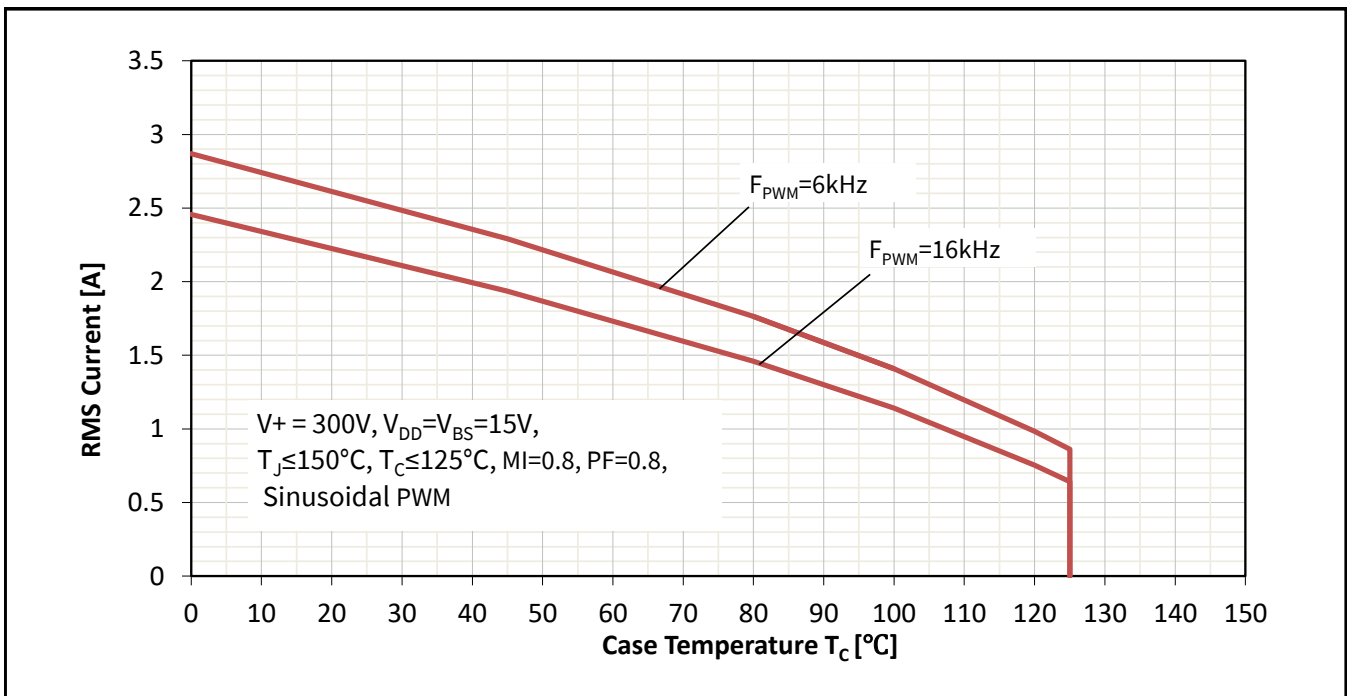

Figure 11 Continuous current using a typical loss and worst case Zthjc model

12.3 T_J vs T_{TH}

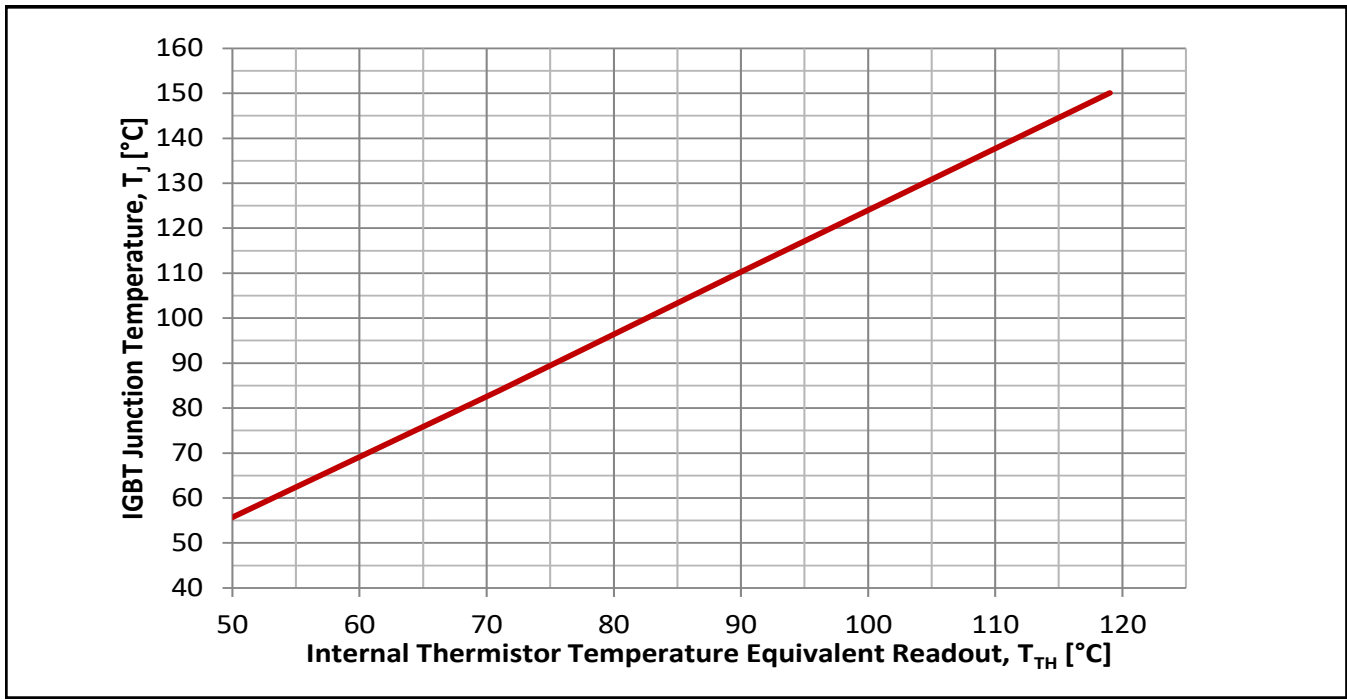

Figure 12 Typical T_J vs T_{TH} correlation

12.4 $-V_S$ Immunity

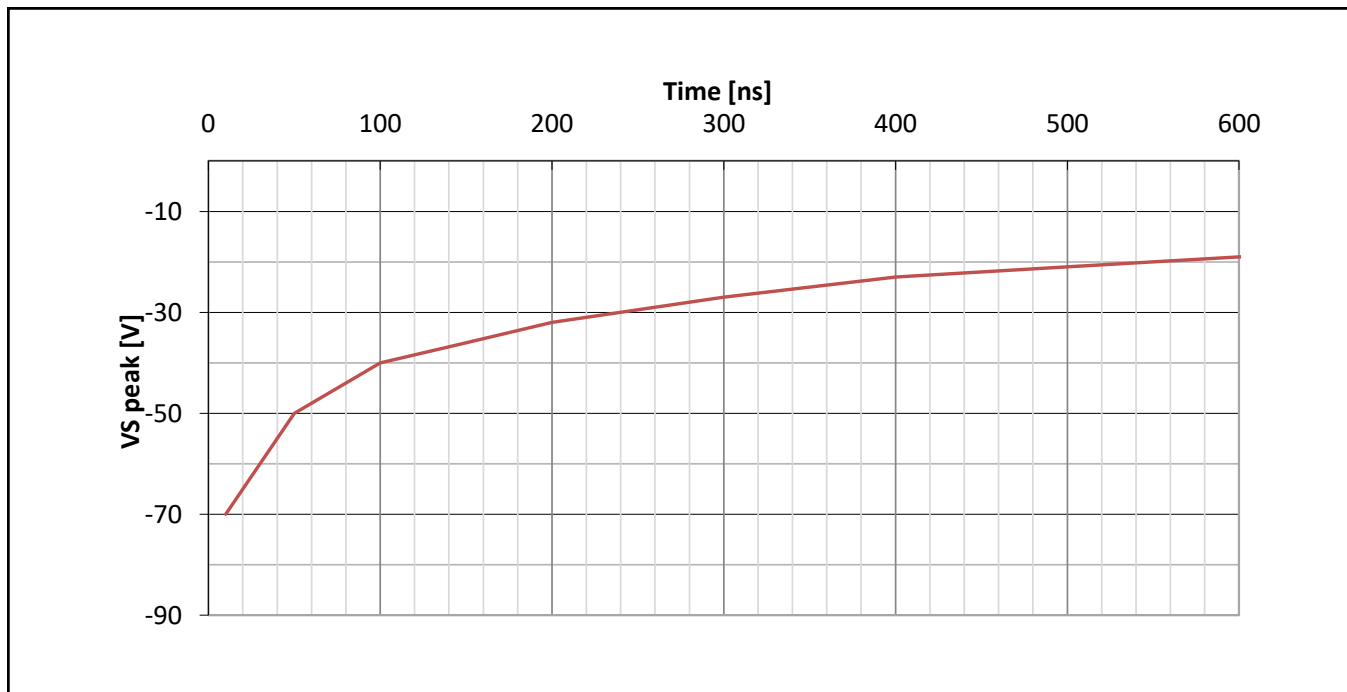
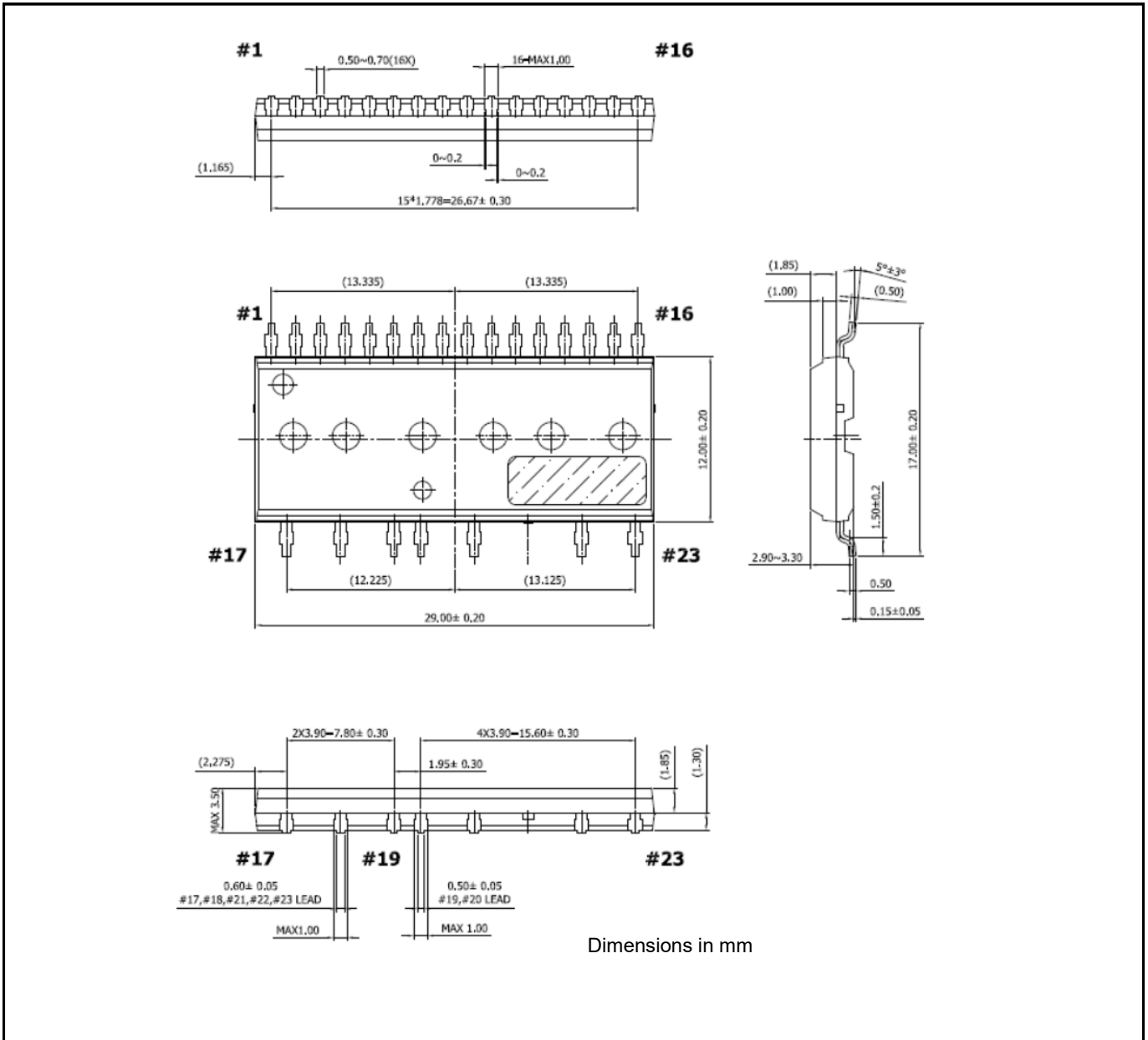

Figure 13 Negative transient V_S SOA for integrated gate driver

Package Information

13 Package Outline

13.1 SOP23



Package Information

13.2 DIP23A

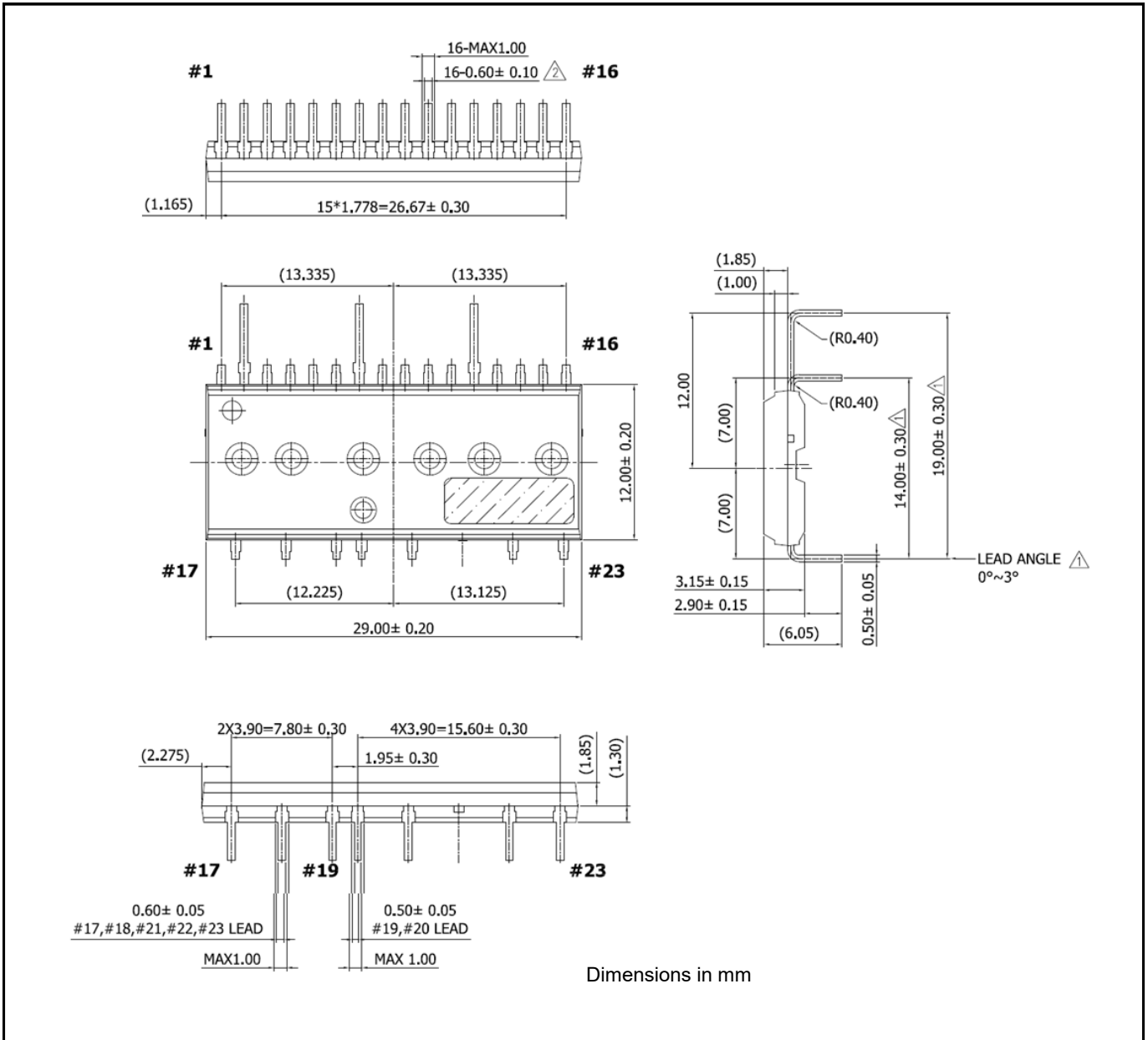

Package Information

13.3 DIP23

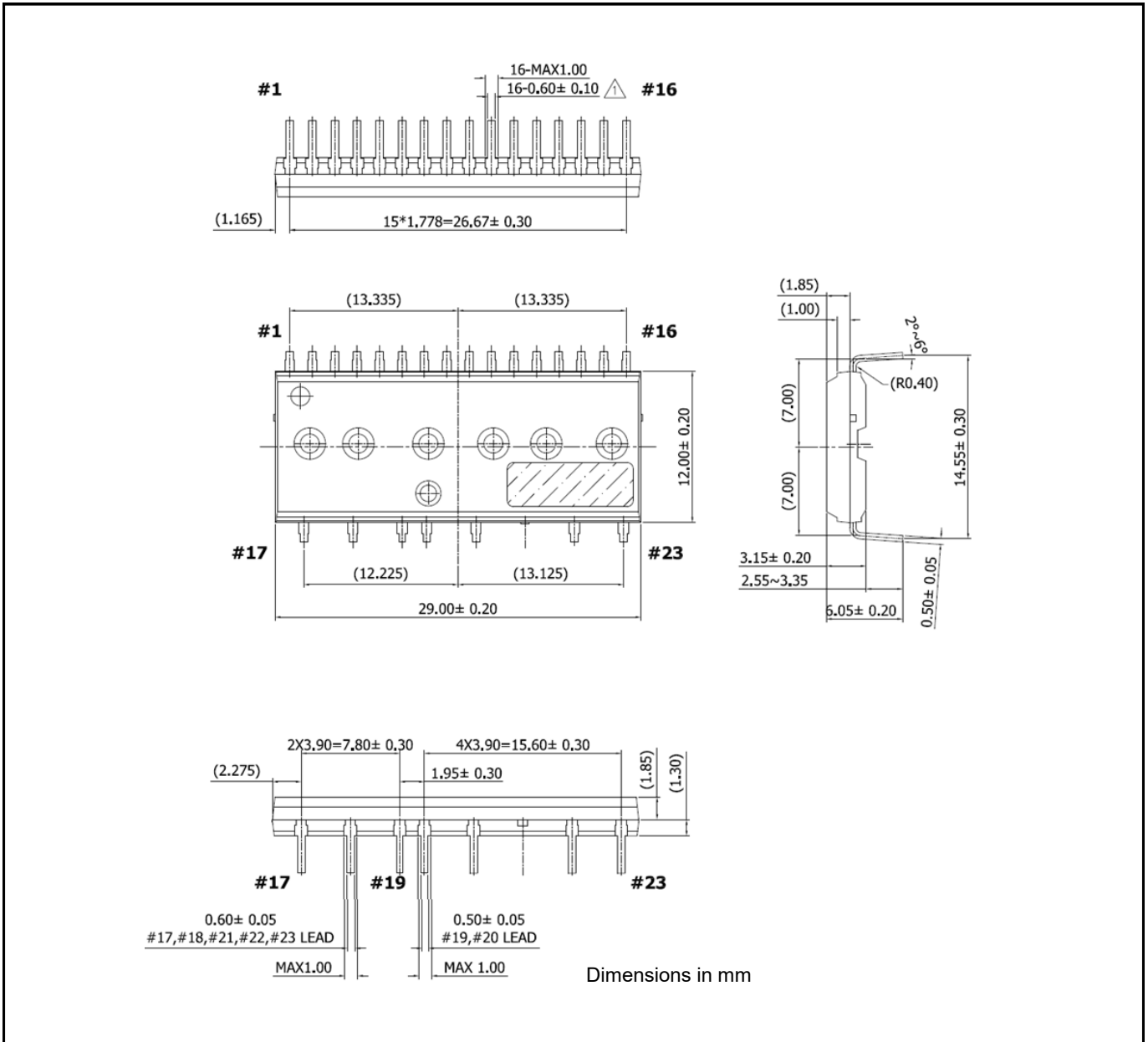

Revision History

14 Revision History

Major changes since the last revision

Page or Reference	Description of changes
	Final Datasheet

Other Trademarks

All referenced product or service names and trademarks are the property of their respective owners.

Edition 2018-03-02
Published by
Infineon Technologies AG
81726 Munich, Germany

© 2019 Infineon Technologies AG.
All Rights Reserved.

Do you have a question about this document?
Email: erratum@infineon.com

Document reference

IMPORTANT NOTICE

The information given in this document shall in no event be regarded as a guarantee of conditions or characteristics ("Beschaffenheitsgarantie").

With respect to any examples, hints or any typical values stated herein and/or any information regarding the application of the product, Infineon Technologies hereby disclaims any and all warranties and liabilities of any kind, including without limitation warranties of non-infringement of intellectual property rights of any third party.

In addition, any information given in this document is subject to customer's compliance with its obligations stated in this document and any applicable legal requirements, norms and standards concerning customer's products and any use of the product of Infineon Technologies in customer's applications.

The data contained in this document is exclusively intended for technically trained staff. It is the responsibility of customer's technical departments to evaluate the suitability of the product for the intended application and the completeness of the product information given in this document with respect to such application.

For further information on the product, technology, delivery terms and conditions and prices please contact your nearest Infineon Technologies office (www.infineon.com).

WARNINGS

Due to technical requirements products may contain dangerous substances. For information on the types in question please contact your nearest Infineon Technologies office.

Except as otherwise explicitly approved by Infineon Technologies in a written document signed by authorized representatives of Infineon Technologies, Infineon Technologies' products may not be used in any applications where a failure of the product or any consequences of the use thereof can reasonably be expected to result in personal injury.