

RoHS

Type-C to DP/m black L = 1800mm space gray aluminum shell

REV.	DESCRIPTION/REASON	MADE BY	APP'D BY	DATE
01	RELEASE FOR PRODUCTION			

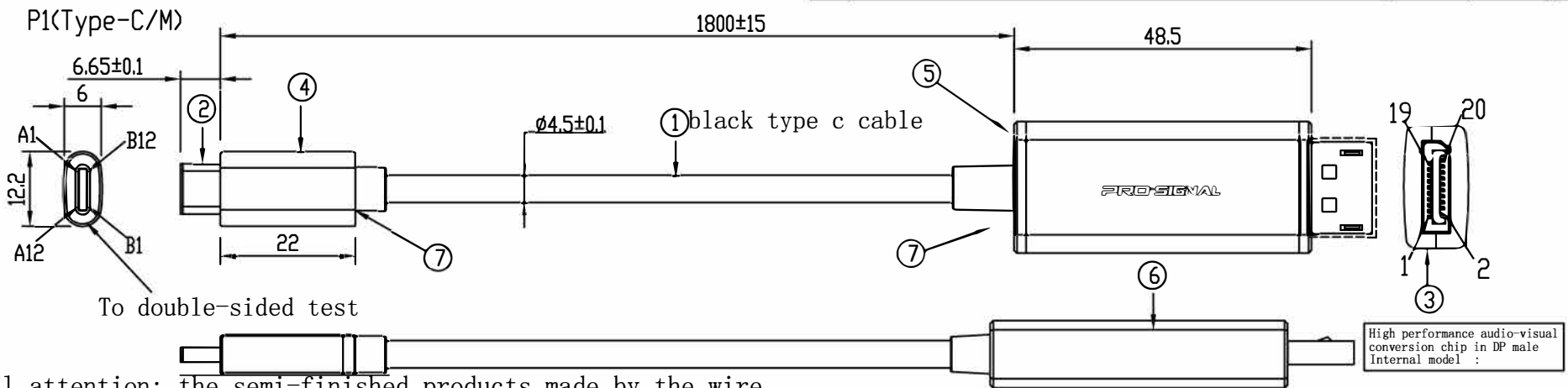

Special attention: the semi-finished products made by the wire end must be tested to be OK before they are put on the finished product line

test condition:

- 1.100% open, short and exchange test.
- 2.On resistance: 2 ohms maximum.
- 3.Insulation impedance: 10 megohm minimum / dc100v / 10ms (wire end)
- 4.100% on-board test, and pass the test of Apple's new generation notebook computer (double-sided test of USB plug)
- 5.DP bus terminal wiring must be tested with standard DP wire (resolution up to 3840x2160 @ 60Hz)

points for attention:

- 1.After the wire end is sent out by the warehouse, pay attention to the appearance self inspection and then put into production
- 2.Please refer to operation instruction for detailed operation mode.
- 3.The shell at both ends shall not be scratched, scratched, and other defects.
- The baffle plates at both ends shall be assembled tightly without obvious gaps
- 4.The molding part must not be filled with glue, lack of glue and dirty.
- 5.The dimension of the finished product must be fully inspected in strict accordance with the drawing
- 6.Please refer to the detailed operation instruction for more precautions

P1(TYPE C/M)	colour	P2(DP/M-PCBA)
GND	GND	GND
A2	white	A2
A3	blue	A3
GND	GND	GND
B11	white	B11
B10	green	B10
GND	GND	GND
B3	red	B3
B2	white	B2
GND	GND	GND
A10	brown	A10
A11	white	A11
A8	gray	A8
B5	yellow	B5
A7	green	A7
A6	white	A6
B8	purple	B8
A5	orange	A5
A4	red	A4
ironclad	braided	ironclad

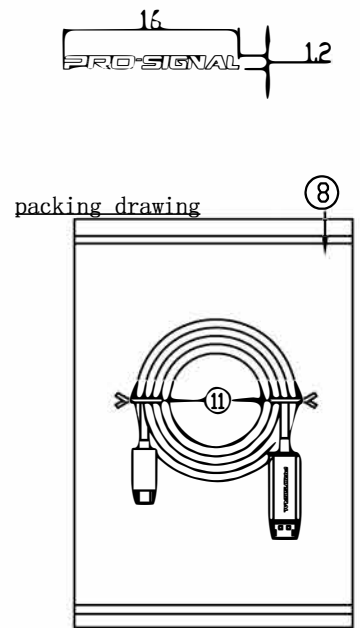

Item	Name	Description	Q'TY	UNIT	Remark
8	PACK	White composite bag packaging 210 * 170	1	PCS	
7	PVC	PVC plug rubber 45p black	16	G	
6	PCBA	1.6 CDPM CHIP:CY7C10PD2119 DP male end plat			
5	SHELL	39.5mm space gray countersunk head + highlight sandblast	1801	PCS	
4	SHELL	21.9mm type C space gray aluminum shell (integrated type) sandblast 180	1	PCS	
3	CONN	DP male gold-plated plywood type (with rubber edge)	1	PCS	
2	CONN	1.6 black rubber core	1	PCS	
1	WIRE	Type-C 3.1 male gold-plated card wire type black rubber core (1P*32#+D+AL+ML) *4+1P*32#+4C*32#+1C*22#+D+AL+B OD:4.5 Black outer cover	1800	MM	

AR		REV. A	DATE	UNIT: mm
DRAWN		<i>[Signature]</i>	Oct/31/2019	UNSPECIFIED TOLERANCE
MATERIAL		CHECKED		X.XX=±0.10
HUIANG		APPROVED		Z.X.X=±0.5°
SCALE 1:1		FINISH		PROJECTION
D		A4		