

FKM-FS57-M12

Accessories for Fieldbus Systems – Wall/panel feed-through

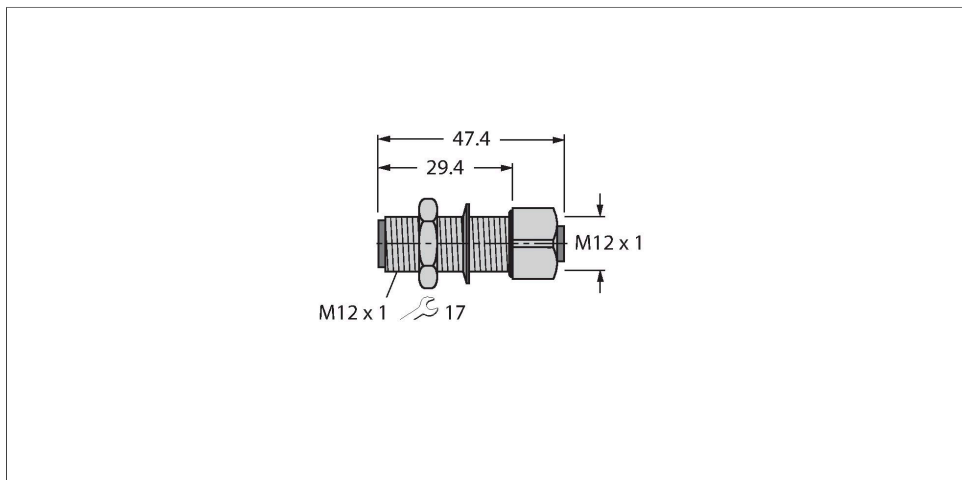

Features

- Type: M12 adapter
- 5-pin feedthrough male/female connector
- For use in CAN (DeviceNet™, CANopen) applications
- Ampacity: 4 A
- Rated voltage: 150 V
- Temperature range: -40 °C...+105 °C
- Protection class: NEMA 1, 3, 4, 6P and IEC IP67

Diagram

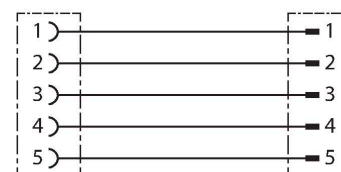

Technical data

Type	FKM-FS57-M12
Ident. no.	6602223
Connector A	Wall Feedthrough/Female Receptacle, M12 × 1, Straight
Number of contacts	5
Contacts	Brass, CuZn, Gold-plated
Contact carriers	Plastic, TPU, Blue
Connector body	Brass, CuZn, Nickel-plated
Mounting orientation	Front mount
Mounting thread	M12x1
Mechanical life	> 100 Mating cycles
Pollution degree	3
Protection class	When coupled - IP67, (screwed together)
Connector B	Male receptacle
Fieldbus	DeviceNet™ CANopen
Rated voltage	150 V
Current	4 A
Insulation resistance	≥ 10 ⁸ Ω
forward resistance	≤ 5 mΩ
Temperature range (static)	-40 °C...+105 °C