



The Future of Analog IC Technology™

MP1540

1.3MHz, 18V Step-Up Converter

DESCRIPTION

The MP1540 is a 5-pin thin TSOT23 current mode step-up converter intended for small, low power applications. The MP1540 switches at 1.3MHz and allows the use of tiny, low cost capacitors and inductors 2mm or less in height. Internal soft-start results in small inrush current and extends battery life. The MP1540 operates from an input voltage as low as 2.5V and can generate 12V at up to 200mA from a 5V supply.

The MP1540 includes under voltage lockout, current limiting, and thermal overload protection to prevent damage in the event of an output overload. The MP1540 is available in a small 5-pin TSOT23 package.

FEATURES

- On Board Power MOSFET
- Uses Tiny Capacitors and Inductors
- 1.3MHz Fixed Switching Frequency
- Internal Soft-Start
- Operates with Input Voltage as Low as 2.5V and Output Voltage as High as 18V
- 12V at 200mA from 5V Input
- UVLO, Thermal Shutdown
- Internal Current Limit
- Available in a TSOT23-5 Package

APPLICATIONS

- Camera Phone Flash
- Handheld Computers and PDAs
- Digital Still and Video Cameras
- External Modems
- Small LCD Displays
- White LED Driver

"MPS" and "The Future of Analog IC Technology" are Trademarks of Monolithic Power Systems, Inc.

TYPICAL APPLICATION

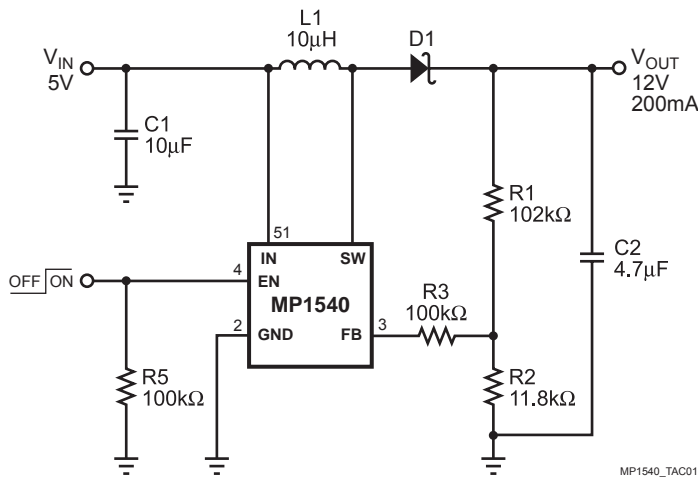

Efficiency vs Load Current

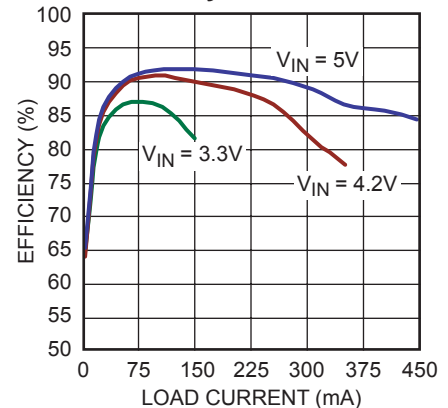

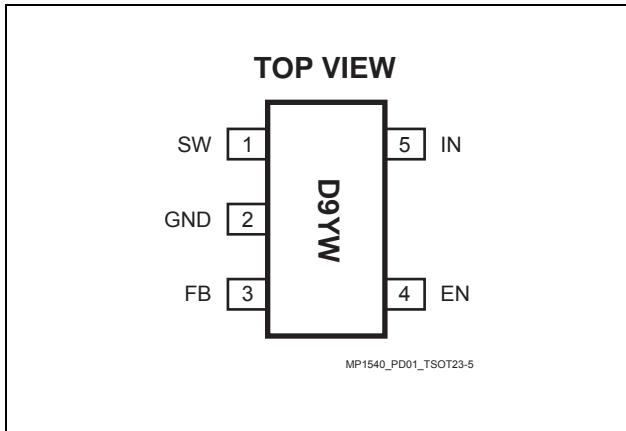
PACKAGE REFERENCE

Part Number*	Package	Temperature
MP1540DJ	TSOT23-5	-40°C to +85°C

* For Tape & Reel, add suffix -Z (eg. MP1540DJ-Z)
 For Lead Free, add suffix -LF (eg. MP1540DJ-LF-Z)

ABSOLUTE MAXIMUM RATINGS ⁽¹⁾

SW Pin	-0.3V to +20V
All Other Pins	-0.3V to +6.5V
Junction Temperature	150°C
Lead Temperature	260°C
Storage Temperature	65°C to 150°C

Recommended Operating Conditions ⁽²⁾

Supply Voltage V_{IN}	2.5V to 6V
Output Voltage V_{OUT}	3V to 18V
Operating Temperature	-40°C to +85°C

Thermal Resistance ⁽³⁾	θ_{JA}	θ_{JC}
TSOT23-5.....	220.....	110 .. °C/W

Notes:

- Exceeding these ratings may damage the device.
- The device is not guaranteed to function outside of its operating conditions.
- Measured on approximately 1" square of 1 oz copper.

ELECTRICAL CHARACTERISTICS

$V_{IN} = V_{EN} = 5V$, $T_A = +25^\circ C$ unless specified otherwise.

Parameters Sy	mbol	Condition	Min	Typ	Max	Units
Operating Input Voltage	V_{IN}		2.5		6	V
Under Voltage Lockout				2.25	2.45	V
Under Voltage Lockout Hysteresis				92		mV
Supply Current (Shutdown)		$V_{EN} = 0V$		0.1	1	μA
Supply Current (Quiescent)		$V_{FB} = 1.3V$		635	850	μA
Switching Frequency	f_{SW}		1.0	1.3	1.6	MHz
Maximum Duty Cycle		$V_{FB} = 0V$	80	85		%
EN Threshold		V_{EN} Rising	1.0	1.3	1.6	V
EN Threshold		V_{EN} Rising, $V_{IN} = 2.5V$		1.1		V
EN Hysteresis			100			mV
EN Input Bias Current		$V_{EN} = 0V, 6V$			1	μA
FB Voltage	V_{FB}		1.21	1.25	1.29	V
FB Input Bias Current		$V_{FB} = 1.25V$	-100	-30	nA	
SW On-Resistance ⁽⁴⁾ R	$DS(ON)$		0.65			Ω
SW Current Limit ⁽⁴⁾				1.9		A
SW Leakage		$V_{SW} = 15V$			1	μA
Thermal Shutdown ⁽⁴⁾			160			°C

Note:

4) Guaranteed by design.

TYPICAL PERFORMANCE CHARACTERISTICS

$V_{IN} = V_{EN} = 5V$, $T_A = +25^\circ C$ unless specified otherwise.

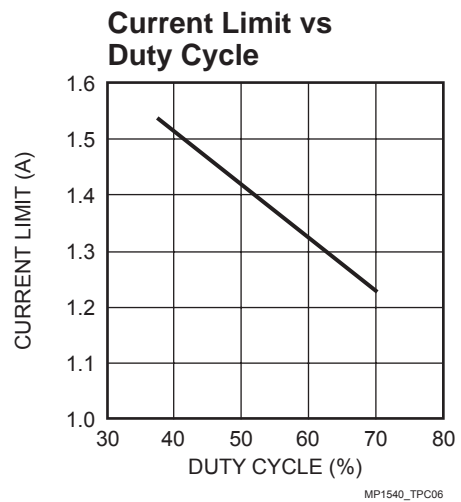
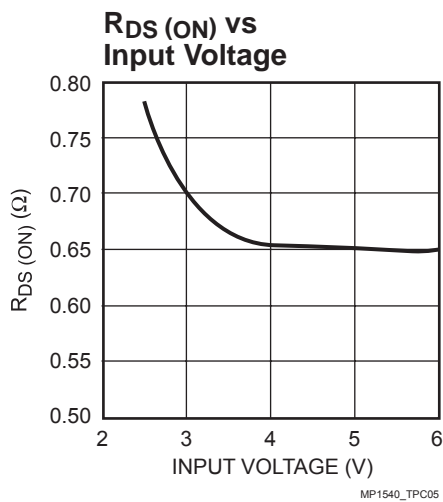
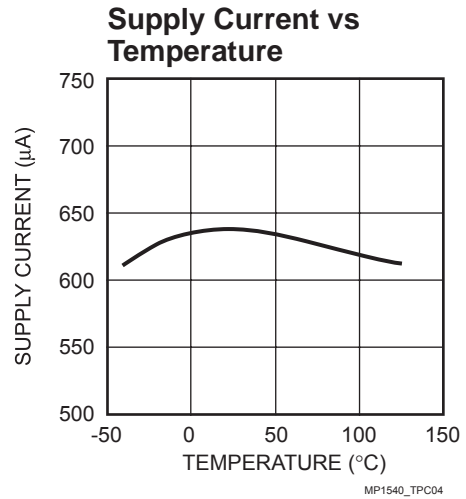
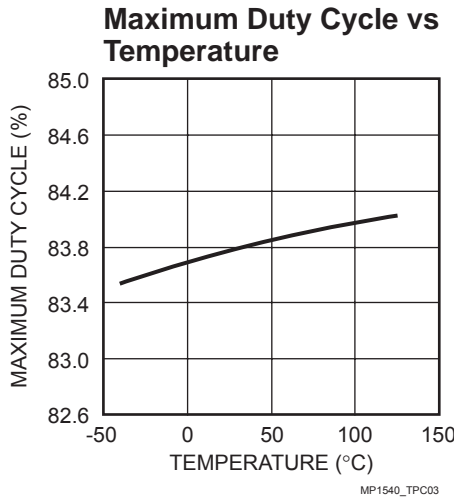
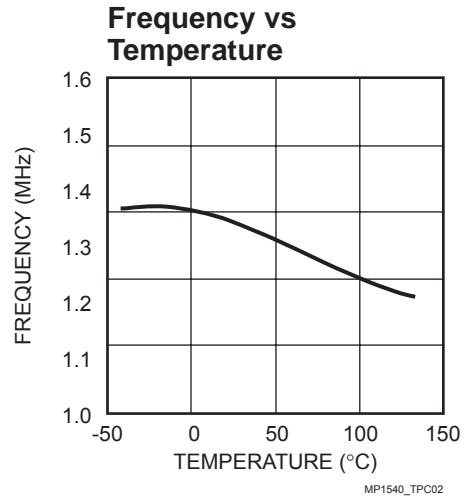
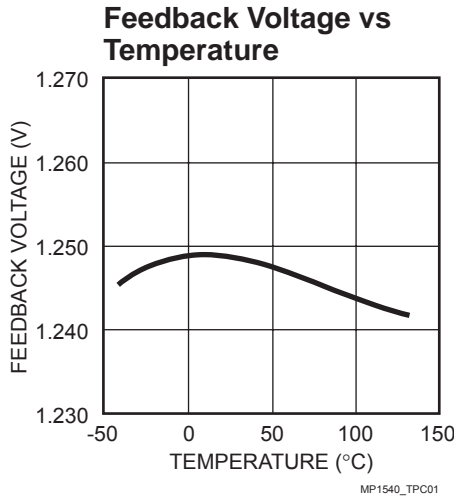

PIN FUNCTIONS

Pin #	Name	Pin Function
1	SW	Power Switch Output. SW is the drain of the internal MOSFET switch. Connect the power inductor and output rectifier to SW. SW can swing between GND and 20V.
2	GND	Ground.
3	FB	Feedback Input. FB voltage is 1.25V. Connect a resistor divider to FB.
4	EN	Regulator On/Off Control Input. A high input at EN turns on the converter, and a low input turns it off. When not used, connect EN to the input source for automatic startup. The EN pin cannot be left floating.
5	IN	Input Supply Pin. Must be locally bypassed.

OPERATION

The MP1540 uses a fixed frequency, peak current mode boost regulator architecture to regulate voltage at the feedback pin. The operation of the MP1540 can be understood by referring to the block diagram of Figure 1.

At the start of each oscillator cycle the MOSFET is turned on through the control circuitry. To prevent sub-harmonic oscillations at duty cycles greater than 50 percent, a stabilizing ramp is added to the output of the current sense amplifier and the result is fed into the negative input of the PWM comparator. When this voltage equals the output voltage of the error amplifier the power MOSFET is turned off.

The voltage at the output of the error amplifier is an amplified version of the difference between the 1.25V bandgap reference voltage and the feedback voltage. In this way the peak current level keeps the output in regulation. If the feedback voltage starts to drop, the output of the error amplifier increases. This results in more current to flow through the power MOSFET, thus increasing the power delivered to the output.

The MP1540 has internal soft start to limit the amount of input current at startup and to also limit the amount of overshoot on the output. The current limit is increased by a fourth every 40µs giving a total soft start time of 120µs.

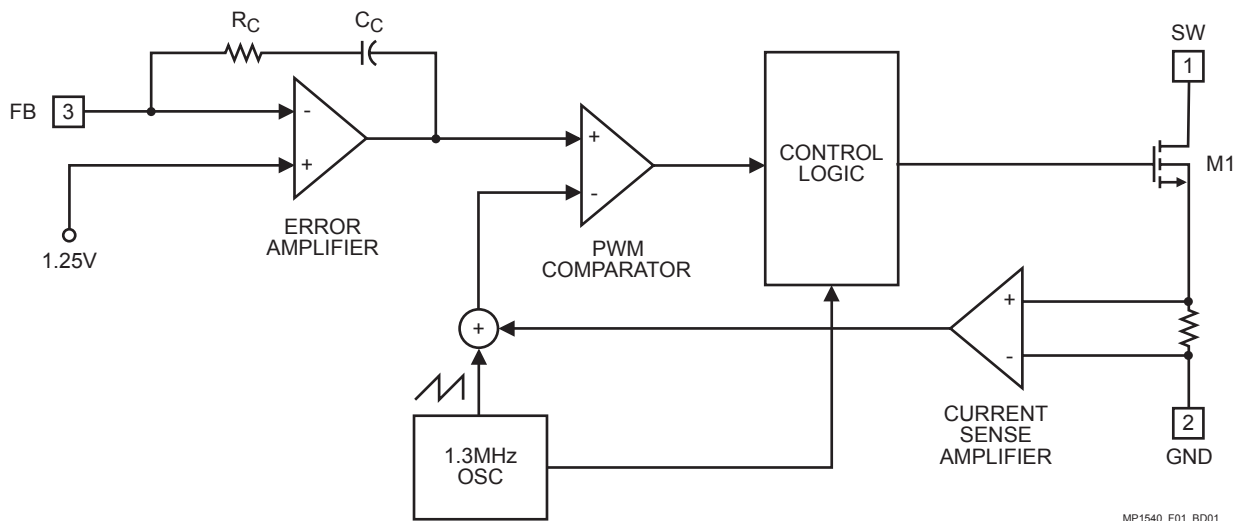

Figure 1—Functional Block Diagram

APPLICATIONS INFORMATION

COMPONENT SELECTION

Setting the Output Voltage

Set the output voltage by selecting the resistive voltage divider ratio. Use 11.8kΩ for the low-side resistor R2 of the voltage divider. Determine the high-side resistor R1 by the equation:

$$R1 = \frac{R2(V_{OUT} - V_{FB})}{V_{FB}}$$

Where V_{OUT} is the output voltage and V_{FB} is the feedback voltage.

For $R2 = 11.8k\Omega$ and $V_{FB} = 1.25V$, then

$$R1 (k\Omega) = 9.44k\Omega (V_{OUT} - 1.25V).$$

Selecting the Input Capacitor

An input capacitor is required to supply the AC ripple current to the inductor, while limiting noise at the input source. This capacitor must have low ESR, so ceramic is the best choice.

Use an input capacitor value of 4.7 μF or greater. This capacitor must be placed physically close to the IN pin. Since it reduces the voltage ripple seen at IN, it also reduces the amount of EMI passed back along that line to the other circuitry.

Selecting the Output Capacitor

A single 4.7μF to 10 μF ceramic capacitor usually provides sufficient output capacitance for most applications. If larger amounts of capacitance are desired for improved line support and transient response, tantalum capacitors can be used in parallel with the ceramic. The impedance of the ceramic capacitor at the switching frequency is dominated by the capacitance, and so the output voltage ripple is mostly independent of the ESR. The output voltage ripple V_{RIPPLE} is calculated as:

$$V_{RIPPLE} = \frac{I_{LOAD}(V_{OUT} - V_{IN})}{V_{OUT} \times C2 \times f_{SW}}$$

Where V_{IN} is the input voltage, I_{LOAD} is the load current, $C2$ is the capacitance of the output capacitor, and f_{SW} is the 1.3MHz switching frequency.

Selecting the Inductor

The inductor is required to force the output voltage higher while being driven by the lower input voltage. Choose an inductor that does not saturate at the SW current limit. A good rule for determining the inductance is to allow the peak-to-peak ripple current to be approximately 30%-50% of the maximum input current. Make sure that the peak inductor current is below 75% of the typical current limit at the duty cycle used to prevent loss of regulation due to the current limit variation.

Calculate the required inductance value L using the equations:

$$L = \frac{V_{IN}(V_{OUT} - V_{IN})}{V_{OUT} \times f_{SW} \times \Delta I}$$

$$I_{IN(MAX)} = \frac{V_{OUT} \times I_{LOAD(MAX)}}{V_{IN} \times \eta}$$

$$\Delta I = (30\% - 50\%) I_{IN(MAX)}$$

Where $I_{LOAD(MAX)}$ is the maximum load current, ΔI is the peak-to-peak inductor ripple current and η is efficiency. For the MP1540, 4.7μH is recommended for input voltages less than 3.3V and 10μH for inputs greater than 3.3V.

Selecting the Diode

The output rectifier diode supplies current to the inductor when the internal MOSFET is off. To reduce losses due to diode forward voltage and recovery time, use a Schottky diode. Choose a diode whose maximum reverse voltage rating is greater than the maximum output voltage. It is recommended to choose the MBR0520 for most applications. This diode is used for load currents less than 500mA. If the average current is more than 500mA the Microsemi UPS5817 is a good choice.

Compensation

The MP1540 uses an amplifier to compensate the feedback loop rather than a traditional transconductance amplifier like most current mode regulators. Frequency compensation is provided by an internal resistor and capacitor along with an external resistor. The system uses two poles and one zero to stabilize the control loop. The poles are f_{P1} set by the output capacitor and load resistance, and f_{P2} set by the internal compensation capacitor, the gain of the error amplifier and the resistance seen looking out at the feedback node R_{EQ} . The zero f_{Z1} is set internally around 20KHz. These are determined by the equations:

$$f_{P1} = \frac{1}{\pi \times C2 \times R_{LOAD}}$$

$$f_{P2} = \frac{1}{2 \times \pi \times (7.9 \times 10^{-9}) \times R_{EQ}}$$

$$f_{Z1} = 20\text{KHz}$$

Where R_{LOAD} is the load resistance and R_{EQ} is:

$$R_{EQ} = R3 + \frac{(R1 \times R2)}{(R1 + R2)}$$

Where R1, R2, and R3 are seen in Figure 2.

The DC loop gain is:

$$A_{VDC} = 500 \times \frac{V_{IN} \times R_{LOAD} \times V_{FB}}{V_{OUT}^2}$$

There is also a right-half-plane zero (f_{RHPZ}) that exists in all continuous mode (inductor current does not drop to zero on each cycle) step up converters. The frequency of the right half plane zero is:

$$f_{RHPZ} = \frac{V_{IN}^2 \times R_{LOAD}}{2 \times \pi \times L \times V_{OUT}^2}$$

To stabilize the regulation control loop, the crossover frequency (the frequency where the loop gain drops to 0dB or a gain of 1, indicated as f_C) should be at least one decade below the right-half-plane zero and should be at most 75KHz. f_{RHPZ} is a function of load current at maximum output load current (R_{LOAD} is at a minimum) and minimum input voltage.

For the MP1540 it is recommended that a 47kΩ to 100kΩ resistor be placed in series with the FB pin and the resistor divider as seen in Figure 2. For most applications this is all that is needed for stable operation. If greater phase margin is needed a series resistor and capacitor can be placed in parallel with the high-side resistor R1 as seen in Figure 2. The pole and zero set by the lead-lag compensation network are:

$$f_{P3} = \frac{1}{2 \times \pi \times C3 \times \left(R4 + \frac{1}{\frac{1}{R1} + \frac{1}{R2} + \frac{1}{R3}} \right)}$$

$$f_{Z2} = \frac{1}{2 \times \pi \times C3 \times (R1 + R4)}$$

Layout Considerations

High frequency switching regulators require very careful layout for stable operation and low noise. All components must be placed as close to the IC as possible. Keep the path between L1, D1, and C2 extremely short for minimal noise and ringing. C1 must be placed close to the IN pin for best decoupling. All feedback components must be kept close to the FB pin to prevent noise injection on the FB pin trace. The ground return of C1 and C2 should be tied close to the GND pin.

TYPICAL APPLICATIONS

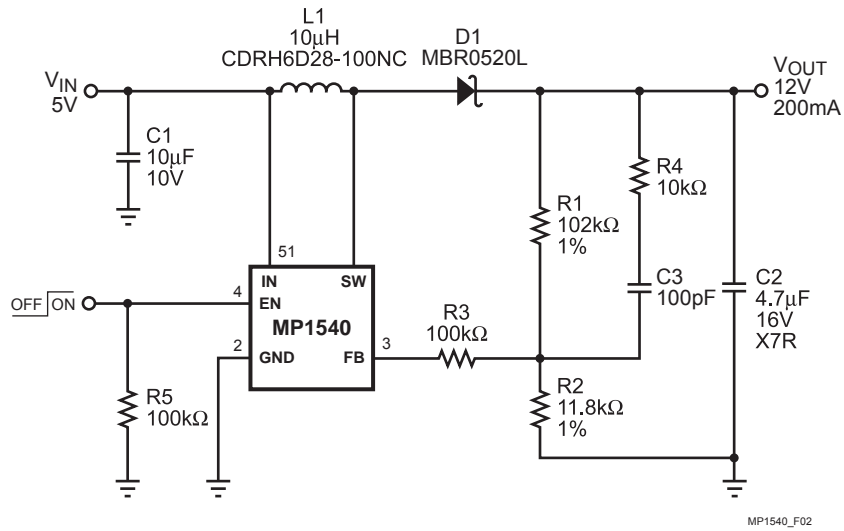

Figure 2— $V_{IN} = 5V$, $V_{OUT} = 12V$, $I_{OUT} = 200mA$ Boost Circuit

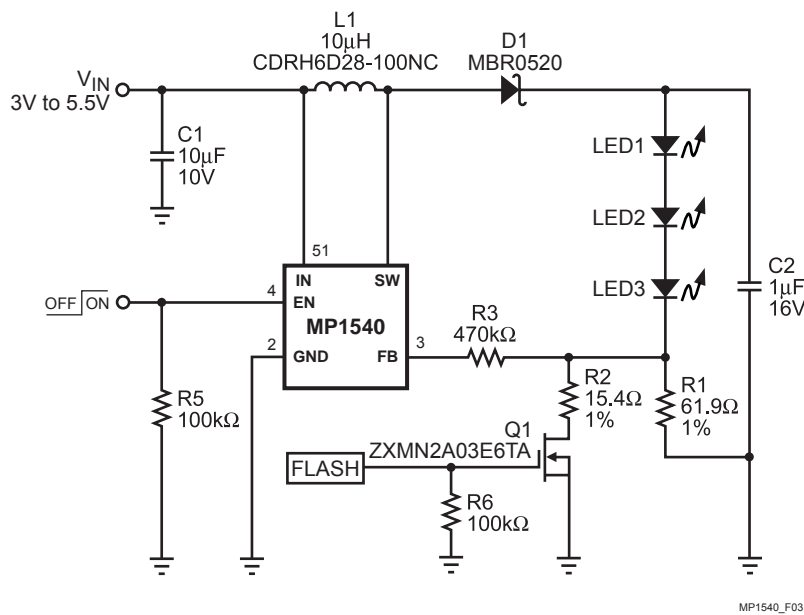
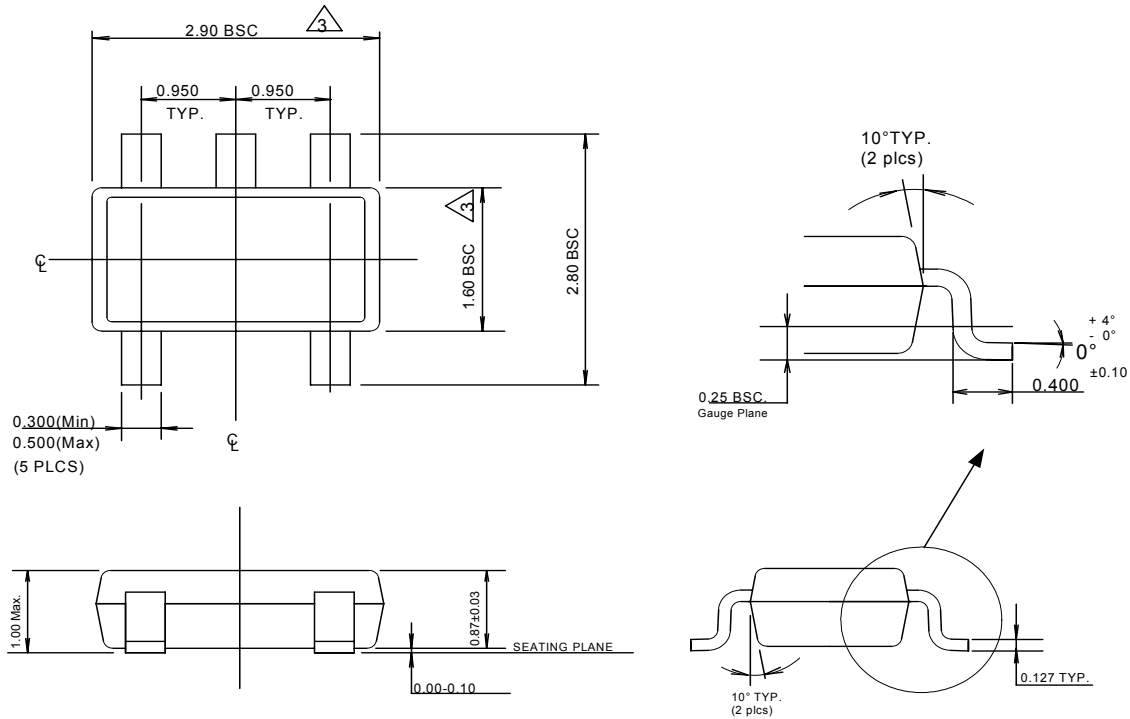

Figure 3—Typical Application Circuit for Driving Flashlight LEDs (20mA Torch Current, 100mA Flash Current)

PACKAGE INFORMATION

TSOT23-5



NOTE:

1. Dimensions and tolerances are as per ANSI Y14.5M, 1994.
2. Die is facing up for mold. Die is facing down for trim/form, ie. reverse trim/form.
3. Dimensions are exclusive of mold flash and gate burr.
4. The footlength measuring is based on the gauge plane method.
5. All specification comply to Jedec Spec MO193 Issue C.

NOTICE: The information in this document is subject to change without notice. Please contact MPS for current specifications. Users should warrant and guarantee that third party Intellectual Property rights are not infringed upon when integrating MPS products into any application. MPS will not assume any legal responsibility for any said applications.