

# Antenna - RAD-900-ANT-OMNI-2-N - 2904802

Please be informed that the data shown in this PDF Document is generated from our Online Catalog. Please find the complete data in the user's documentation. Our General Terms of Use for Downloads are valid (<http://phoenixcontact.com/download>)



Omnidirectional antenna, 868 MHz / 900 MHz, gain: 2 dBi, polarization: linear, opening angle: h/v 360°/50°, degree of protection: IP66, connection: N (female), for control cabinet mounting (optional wall mounting)

## Your advantages

- For freely mobile applications
- For multipoint or mesh connections



## Key Commercial Data

Packing unit	1 pc
GTIN	 4 046356 916844
GTIN	4046356916844
Weight per Piece (excluding packing)	178.100 g
Custom tariff number	85177000
Country of origin	United States

## Technical data

### Dimensions

Height	84 mm
Diameter	36 mm

### Ambient conditions

Degree of protection	IP66
Ambient temperature (operation)	-40 °C ... 70 °C
Ambient temperature (storage/transport)	-40 °C ... 70 °C

### General

With connecting cable	No
Frequency range	900 MHz
	868 MHz ... 960 MHz

## Antenna - RAD-900-ANT-OMNI-2-N - 2904802

### Technical data

#### General

Horizontal beamwidth	360 °
Vertical beamwidth	50 °
Polarization	Linear vertical
Impedance	50 Ω
Gain	2.15 dBi
Connection method	Type N (female)
Material	Xenoy 5720U-7014 (Antenna housing)
Mounting type	Control cabinet
Assembly instructions	Optional wall mounting

#### Environmental Product Compliance

REACH SVHC	Lead 7439-92-1
China RoHS	Environmentally friendly use period: unlimited = EFUP-e
	No hazardous substances above threshold values

### Drawings

# Antenna - RAD-900-ANT-OMNI-2-N - 2904802

Schematic diagram

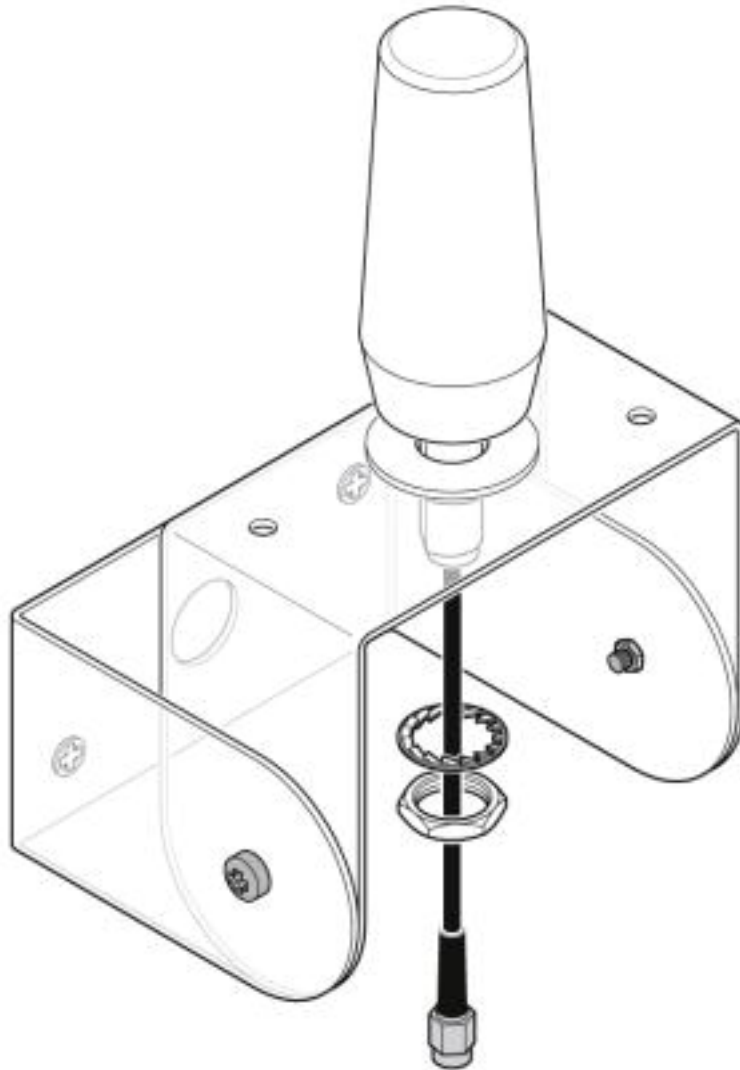

# Antenna - RAD-900-ANT-OMNI-2-N - 2904802

Schematic diagram

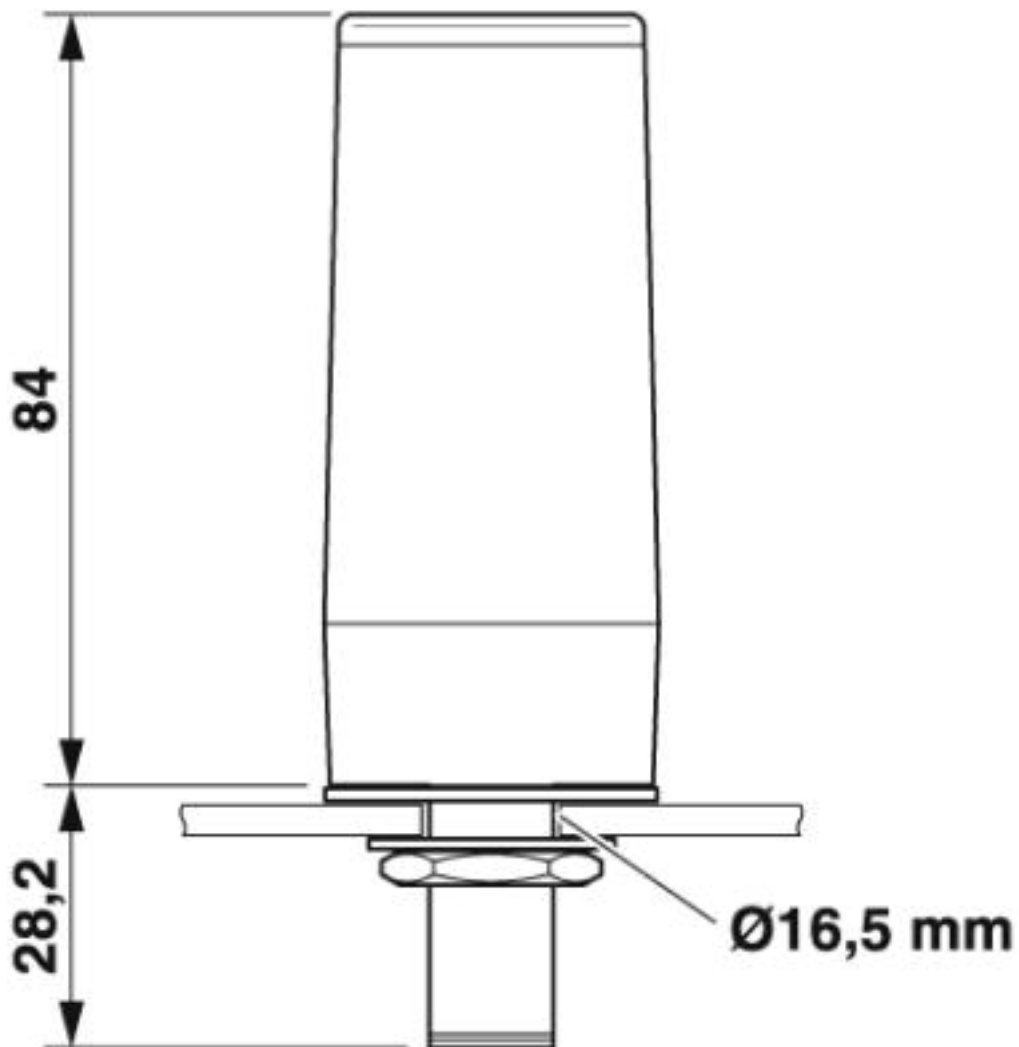

# Antenna - RAD-900-ANT-OMNI-2-N - 2904802

Dimensional drawing

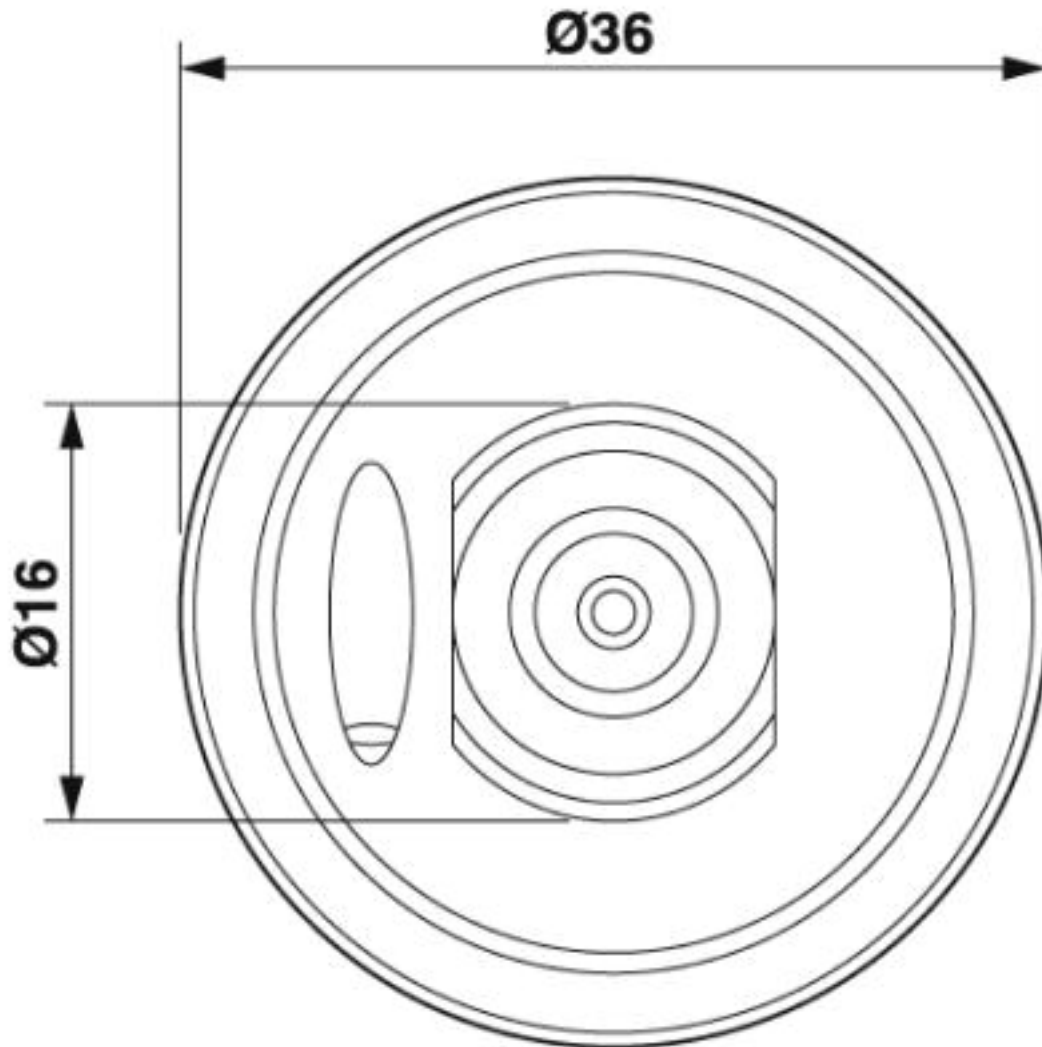

# Antenna - RAD-900-ANT-OMNI-2-N - 2904802

Dimensional drawing

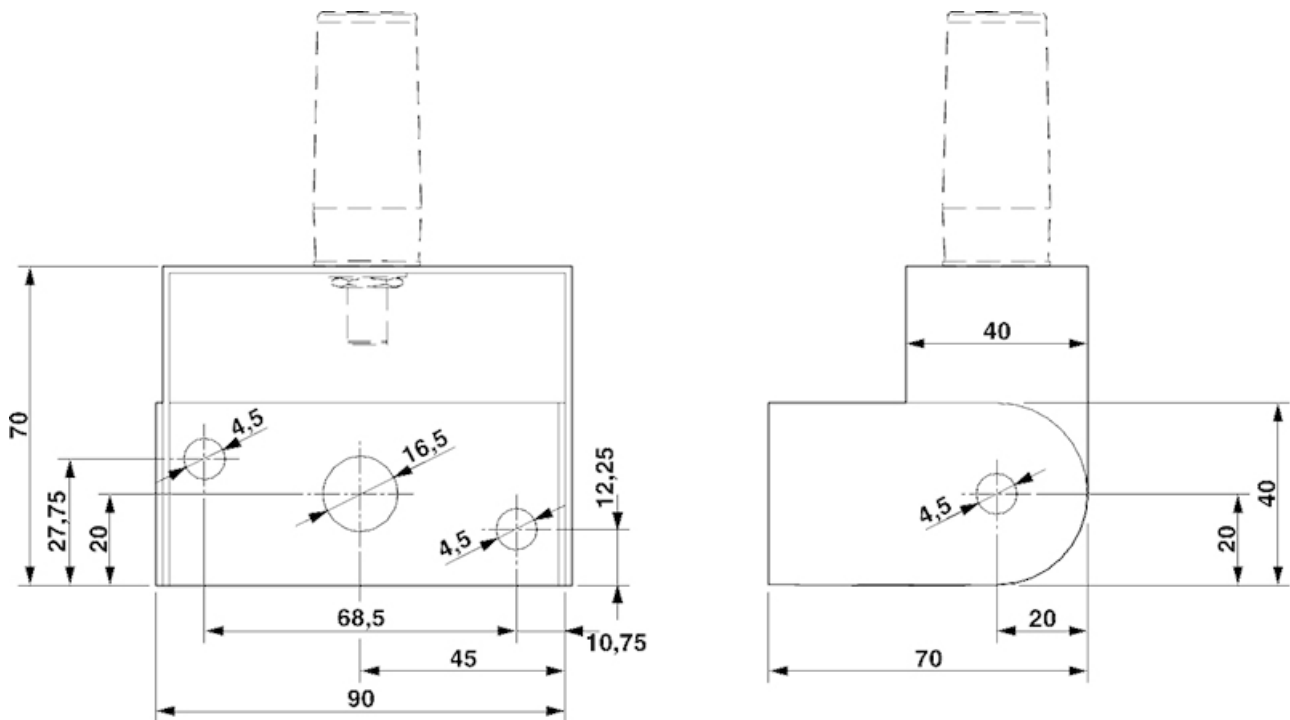

## Classifications

eCl@ss

eCl@ss 4.1	27230200
eCl@ss 5.0	27061800
eCl@ss 5.1	19070100
eCl@ss 6.0	27061800
eCl@ss 7.0	19070105
eCl@ss 8.0	19070105
eCl@ss 9.0	19070105

# Antenna - RAD-900-ANT-OMNI-2-N - 2904802

## Classifications

### ETIM

ETIM 4.0	EC000416
ETIM 5.0	EC001698
ETIM 6.0	EC001698
ETIM 7.0	EC001698

### UNSPSC

UNSPSC 13.2	43221715
UNSPSC 18.0	43221715
UNSPSC 19.0	43221715
UNSPSC 20.0	43221715
UNSPSC 21.0	43221715

## Accessories

### Accessories

#### Mounting material

Mounting material - RAD-ANT-VAN-MKT - 2885870



Mounting material for wall mounting of omnidirectional antenna with protection against vandals