

Click [here](#) for production status of specific part numbers.

## MAX14829

## Low-Power IO-Link Device Transceiver with Dual Drivers

### General Description

The MAX14829 integrates the high-voltage functions commonly found in industrial sensors. The MAX14829 features two ultra low-power drivers with active reverse-polarity protection and is specified for operation with supply voltages from 9V to 60V. The high-voltage tolerance of the MAX14829 allows for the use of micro-TVS, simplifying transient protection.

Pins are used to configure and monitor the device. Driver overload and supply monitor outputs are available. Pin-control allows for operation with switching sensors that do not use a microcontroller.

Two integrated linear regulators (3.3V and 5V) provide low-noise analog and logic supply rails for the device or external circuits.

The MAX14829 is available in a (4mm x 4mm) 24-pin TQFN package and is specified over the extended -40°C to +125°C temperature range.

### Applications

- Industrial Sensors
- IO-Link® Sensors and Actuators
- Safety Applications

### Benefits and Features

- Low Power Dissipation Reduces the Thermal Footprint for Small Sensors
  - 2.3Ω/2.7Ω (typ) Driver On-Resistance
  - 60mW (typ) Operating Power Dissipation
- High Configurability and Integration Reduce SKUs
  - Auxiliary 24V Digital Output (DO) and Input (DI)
  - Selectable Driver Current: 100mA to 330mA
  - Pin-Control Interface for Configuration and Monitoring
  - UART Interface
  - 3.3V and 5V Low-Noise Linear Regulators
  - Optional External Transistor Supports Higher Regulator Load Capability
  - Supervisors Monitor 24V Supply
- Selectable Driver Integrated Protection Enables Robust Communication
  - 65V Absolute Maximum Ratings on Interface and Supply Pins Allows for Flexible TVS Protection
  - 9V to 60V Specified Operation
  - Glitch Filters for Improved Burst and Noise Resilience
  - Thermal Shutdown Autoretry Cycling
  - Hot-Plug V<sub>24</sub> Supply Protection
  - Reverse Polarity Protection of All Sensor Interface Inputs/Outputs
  - -40°C to +125°C Operating Temperature Range

*Ordering Information appears at end of data sheet.*

### Typical Operating Circuit

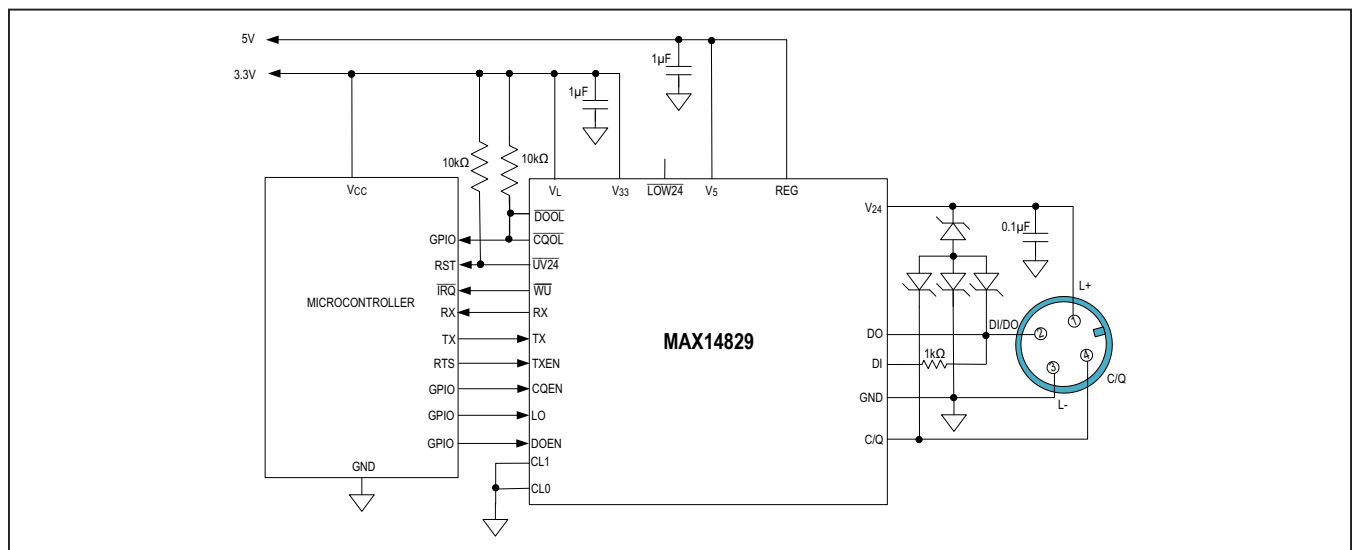

IO-Link is a registered trademark of Profibus User Organization (PNO).

Functional Diagram

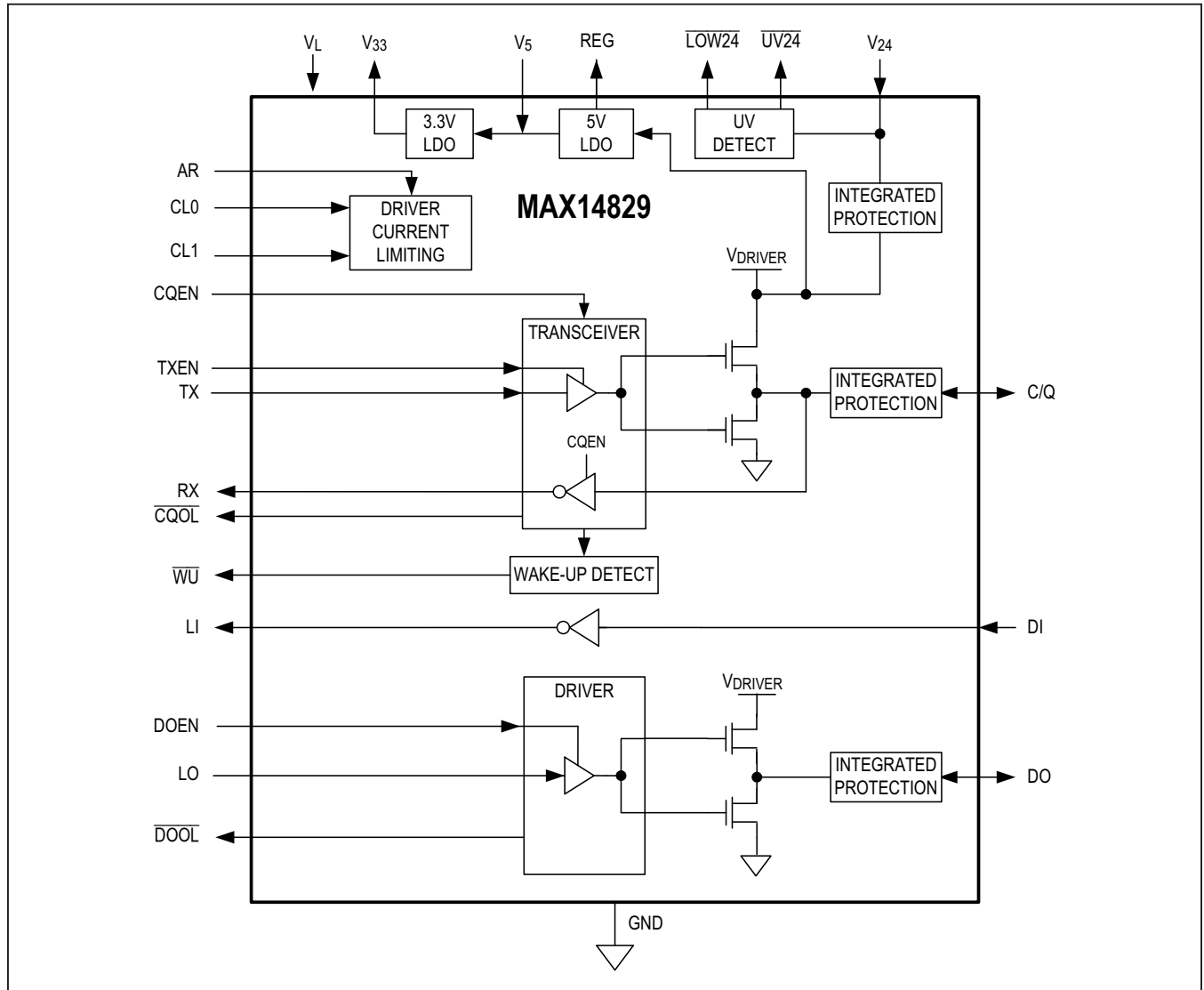

**Absolute Maximum Ratings**

(All voltages referenced to GND, unless otherwise noted.)

V <sub>24</sub> .....	-70V to +65V
REG.....	-0.3V to (V <sub>5</sub> + 16V)
V <sub>5</sub> , V <sub>L</sub> .....	-0.3V to +6V
V <sub>33</sub> .....	-0.3V to (V <sub>5</sub> + 0.3V)
C/Q, DO, DI.....	max(-70V, V <sub>24</sub> - 70V) to min(+70V, V <sub>24</sub> + 70V)
Logic Inputs:	
CL0, CL1, TXEN, TX, LO, CQEN,	
DOEN (Note 1).....	-0.3V to (V <sub>L</sub> + 0.3V)
Logic Outputs:	
RX, LI, WU.....	-0.3V to (V <sub>L</sub> + 0.3V)
LOW24, UV24, CQOL, DOOL.....	-0.3V to +6V
Continuous Current Into GND and V <sub>24</sub> .....	±1A

Continuous Current Into C/Q and DO.....	±500mA
Continuous Current Into V <sub>5</sub> and REG.....	±100mA
Continuous Current Into Any Other Pin.....	±50mA
Continuous Power Dissipation	
TQFN (derate 27.8mW/°C above +70°C).....	2222mW
Operating Temperature Range.....	-40°C to +125°C
Maximum Junction Temperature.....	Internally Limited
Storage Temperature Range.....	-65°C to +150°C
Soldering Temperature	
Soldering, 10s.....	+300°C
Reflow.....	+260°C

Stresses beyond those listed under "Absolute Maximum Ratings" may cause permanent damage to the device. These are stress ratings only, and functional operation of the device at these or any other conditions beyond those indicated in the operational sections of the specifications is not implied. Exposure to absolute maximum rating conditions for extended periods may affect device reliability.

**Note 1:** CQEN is connected to V<sub>5</sub> with an internal diode. Connecting CQEN to a voltage higher than V<sub>5</sub> can result in a large current sink until V<sub>5</sub> rises above CQEN.

**Package Information**

<b>PACKAGE TYPE: 24 TQFN</b>	
Package Code	T2444+4C
Outline Number	<a href="#">21-0139</a>
Land Pattern Number	<a href="#">90-0022</a>
<b>THERMAL RESISTANCE, FOUR-LAYER BOARD</b>	
Junction to Ambient (θ <sub>JA</sub> )	36°C/W
Junction to Case (θ <sub>JC</sub> )	3°C/W

For the latest package outline information and land patterns (footprints), go to [www.maximintegrated.com/packages](http://www.maximintegrated.com/packages). Note that a "+", "#", or "-" in the package code indicates RoHS status only. Package drawings may show a different suffix character, but the drawing pertains to the package regardless of RoHS status.

Package thermal resistances were obtained using the method described in JEDEC specification JESD51-7, using a four-layer board. For detailed information on package thermal considerations, refer to [www.maximintegrated.com/thermal-tutorial](http://www.maximintegrated.com/thermal-tutorial).

**DC Electrical Characteristics**

( $V_{24}$  = 9V to 60V,  $V_5$  = 4.5V to 5.5V,  $V_L$  = 2.5V to 5.5V,  $V_{GND}$  = 0V; REG unconnected, all logic inputs at  $V_L$  or GND;  $T_A$  = -40°C to +125°C, unless otherwise noted. Typical values are at  $V_{24}$  = 24V,  $V_5$  = 5V,  $V_L$  = 3.3V, and  $T_A$  = +25°C, unless otherwise noted.) (Note 2)

PARAMETER	SYMBOL	CONDITIONS		MIN	TYP	MAX	UNITS
$V_{24}$ Supply Voltage	$V_{24}$			9		60	V
$V_{24}$ Undervoltage Lockout Threshold	$V_{24UVLO}$	$V_{24}$ rising		6	7.8	9	V
		$V_{24}$ falling		6	7.2	9	
$V_{24}$ Undervoltage Lockout Threshold Hysteresis	$V_{24UVLO\_HYST}$				570		mV
$V_{24}$ Supply Current	$I_{24}$	$V_5$ powered externally, REG is unconnected	C/Q and DO disabled (CQEN = Low, DOEN = Low)		0.14	0.5	mA
			C/Q and DO high, CL0 = CL1 = High, no load on C/Q or DO		0.96	1.35	
			C/Q and DO low, CL0 = CL1 = High, no load on C/Q or DO		0.98	1.35	
$V_{24}$ Low-Voltage Warning Threshold	$V_{24W}$			14.5	16.5	18	V
$V_5$ Supply Voltage				4.5		5.5	V
$V_5$ Undervoltage-Lockout Threshold	$V_{5UVLO}$	$V_5$ rising		2.8	3.5	4.5	V
		$V_5$ falling		2.8	3.45	4.5	
$V_5$ Supply Current	$I_{5\_IN}$	External 5V applied to $V_5$ , REG is unconnected.	C/Q and DO disabled (CQEN = Low, DOEN = Low)		0.66	1.0	mA
			C/Q and DO high, CL0 = CL1 = High, no load on C/Q, DO, or $V_{33}$		1.42	1.85	
			C/Q and DO low, CL0 = CL1 = High, no load on C/Q, DO, or $V_{33}$		1.56	2.0	
$V_L$ Logic-Level Supply Voltage	$V_L$			2.5		5.5	V
$V_L$ Undervoltage Threshold	$V_{LUVLO}$			0.9	1.7	2.4	V
$V_L$ Logic-Level Supply Current	$I_L$	All logic inputs at $V_L$ or GND, all logic outputs unconnected			0.25	3	$\mu$ A
<b>5V LINEAR REGULATOR (<math>V_5</math>)</b>							
$V_5$ Output Voltage	$V_5$	REG = $V_5$ , no load on $V_5$ , $9V \leq V_{24} \leq 60V$		4.75	5.00	5.25	V
Load Regulation	$\Delta V_{5\_LDR}$	REG = $V_5$ , $0mA \leq I_{LOAD} \leq 30mA$ , $V_{24} = 24V$			0.02	0.2	%
Line Regulation	$\Delta V_{5\_LNR}$	REG = $V_5$ , $I_{LOAD} = 1mA$ , $V_{24}$ from 9V to 60V			0.01	4	mV/V

## DC Electrical Characteristics (continued)

( $V_{24} = 9V$  to  $60V$ ,  $V_5 = 4.5V$  to  $5.5V$ ,  $V_L = 2.5V$  to  $5.5V$ ,  $V_{GND} = 0V$ ; REG unconnected, all logic inputs at  $V_L$  or GND;  $T_A = -40^\circ C$  to  $+125^\circ C$ , unless otherwise noted. Typical values are at  $V_{24} = 24V$ ,  $V_5 = 5V$ ,  $V_L = 3.3V$ , and  $T_A = +25^\circ C$ , unless otherwise noted.) (Note 2)

PARAMETER	SYMBOL	CONDITIONS	MIN	TYP	MAX	UNITS	
REG Output Current	$I_{REG}$	Internal regulator or external NPN			30	mA	
$V_{24}$ to REG Dropout Voltage	$\Delta V_{REG}$	$V_{24} = 9V$ , $V_5 = 4.5V$ , $I_{REG} = 5mA$		2.35		V	
REG Open Voltage	$V_{REG\_OPN}$	$V_{24} = 60V$ , $V_5 = 4.5V$ , no load on REG	10	13	16	V	
$V_5$ Capacitance	$CV_5$	Allowed capacitance on $V_5$ , REG connected to $V_5$ (Note 3)	0.8	1	2	$\mu F$	
<b>3.3V LINEAR REGULATOR (<math>V_{33}</math>)</b>							
$V_{33}$ Output Voltage	$V_{33}$	No load on $V_{33}$	3.1	3.3	3.5	V	
$V_{33}$ Load Regulation	$V_{33\_LDR}$	$0mA \leq I_{LOAD} \leq 30mA$	0	0.4	0.8	%	
$V_{33}$ Capacitance	$CV_{33}$	Allowed capacitance on $V_{33}$ (Note 3)	0.8	1		$\mu F$	
<b>C/Q, DO DRIVER</b>							
Driver On-Resistance	$R_{OH}$	High-side enabled, $V_{24} = 24V$ , $CL1 = CL0 = High$ , $I_{LOAD} = 200mA$ (Note 3)		2.65	4.6	$\Omega$	
	$R_{OL}$	Low-side enabled, $V_{24} = 24V$ , $CL1 = CL0 = High$ , $I_{SINK} = 200mA$ (Note 3)		2.3	4.45		
Driver Current Limit	$I_{CL}$	$V_{DRIVER} = (V_{24} - 3V)$ or $3V$	$CL0 = Low$ , $CL1 = Low$	100	125	155	mA
			$CL0 = High$ , $CL1 = Low$	210	252	295	
			$CL0 = Low$ , $CL1 = High$	270	316	365	
			$CL0 = High$ , $CL1 = High$	330	380	430	
Driver Peak Current	$I_{CL\_PEAK}$	DC current, $CL1 = high$ or $low$ , $CL0 = high$ or $low$			490	mA	
C/Q Leakage Current	$I_{LEAK\_CQ}$	C/Q driver is disabled ( $CQEN = Low$ ), $V_{24} = 24V$ , $(V_{24} - 65V) \leq V_{C/Q} \leq +60V$	-70		+10	$\mu A$	
		C/Q driver is disabled ( $CQEN = Low$ ), $V_{24} = 30V$ , $0 \leq V_{C/Q} \leq (V_{24} - 0.5V)$ (Note 3)	-2.5		+2.5		
DO Leakage Current	$I_{LEAK\_DO}$	DO driver is disabled ( $DOEN = Low$ ), $V_{24} = 24V$ , $(V_{24} - 65V) \leq V_{DO} \leq +60V$	-10		+10	$\mu A$	
		DO driver is disabled ( $DOEN = Low$ ), $V_{24} = 30V$ , $0 \leq V_{DO} \leq (V_{24} - 0.5V)$ (Note 3)	-2.5		+2.5		
C/Q Output Reverse Current	$I_{REV\_CQ}$	C/Q driver enabled ( $CQEN = High$ , $TXEN = High$ ), $V_{24} = 30V$ , $V_{C/Q} = (V_{24} + 5V)$ or $-5V$	-60		+1000	$\mu A$	
DO Output Reverse Current	$I_{REV\_DO}$	DO driver enabled ( $DOEN = High$ ), $V_{24} = 30V$ , $V_{DO} = (V_{24} + 5V)$ or $-5V$	-60		+1000	$\mu A$	

**DC Electrical Characteristics (continued)**

( $V_{24}$  = 9V to 60V,  $V_5$  = 4.5V to 5.5V,  $V_L$  = 2.5V to 5.5V,  $V_{GND}$  = 0V; REG unconnected, all logic inputs at  $V_L$  or GND;  $T_A$  = -40°C to +125°C, unless otherwise noted. Typical values are at  $V_{24}$  = 24V,  $V_5$  = 5V,  $V_L$  = 3.3V, and  $T_A$  = +25°C, unless otherwise noted.) (Note 2)

PARAMETER	SYMBOL	CONDITIONS		MIN	TYP	MAX	UNITS
<b>C/Q, DI RECEIVER</b>							
Input Voltage Range	$V_{IN}$	For valid RX/LI logic		$V_{24} - 65$		+65	V
C/Q, DI Input Threshold High	$V_{TH}$	CQEN = High, TXEN = Low	$V_{24} > 18V$	11	11.8	12.5	V
			$V_{24} < 18V$	59	65.5	72	% of $V_{24}$
C/Q, DI Input Threshold Low	$V_{TL}$	CQEN = High, TXEN = Low	$V_{24} > 18V$	9	9.8	10.5	V
			$V_{24} < 18V$	45	54.5	63	% of $V_{24}$
C/Q, DI Input Hysteresis	$V_{HYS\_CQ}$	CQEN = High, TXEN = Low	$V_{24} > 18V$	2			V
			$V_{24} < 18V$	11			% of $V_{24}$
C/Q Input Capacitance	$C_{IN\_CQ}$	CQEN = High, TXEN = Low, $f = 100kHz$			50		pF
DI Input Capacitance	$C_{IN\_DI}$	$f = 100kHz$			10		pF
DI Input Current	$I_{IN\_DI}$	$V_{24} = 24V$	$-5V \leq V_{DI} \leq (V_{24} + 5V)$	-10		+35	$\mu A$
			$(V_{24} - 65V) \leq V_{DI} \leq +60V$	-40		+200	
<b>LOGIC INPUTS (CL0, CL1, TXEN, TX, LO, CQEN, DOEN)</b>							
Logic Input Voltage Low	$V_{IL}$					$0.2 \times V_L$	V
Logic Input Voltage High	$V_{IH}$			$0.8 \times V_L$			V
Logic Input Leakage Current	$I_{LEAK}$	Logic input = GND or $V_L$		-1		+1	$\mu A$
<b>LOGIC OUTPUTS (RX, LI, WU, LOW24, UV24, CQOL, DOOL)</b>							
Logic Output Voltage Low	$V_{OL}$	$I_{SINK} = 5mA$				0.4	V
Logic Output Voltage High	$V_{OH}$	$I_{SOURCE} = 5mA$		$V_L - 0.4$			V
LOW24, UV24, CQOL, DOOL Open-Drain Leakage Current	$I_{LK\_OD}$	LOW24, UV24, CQOL, DOOL high impedance		-1		+1	$\mu A$
<b>THERMAL MANAGEMENT</b>							
C/Q and DO Driver Thermal Shutdown Temperature	$T_{SHUT\_D}$	Driver temperature rising, driver is turned off			+160		°C
C/Q and DO Driver Thermal Shutdown Temperature Hysteresis	$T_{SHUT\_DHYS}$	Driver temperature falling, driver is reenabled			15		°C
IC Thermal Shutdown	$T_{SHUT\_IC}$	Die temperature rising			+170		°C
IC Thermal Shutdown Hysteresis	$T_{SHUT\_ICHYS}$	Die temperature falling			15		°C

## AC Electrical Characteristics

( $V_{24} = 18V$  to  $30V$ ,  $V_5 = 4.5V$  to  $5.5V$ ,  $V_L = 2.5V$  to  $5.5V$ ,  $V_{GND} = 0V$ ; REG unconnected, all logic inputs at  $V_L$  or GND;  $T_A = -40^\circ C$  to  $+125^\circ C$ , unless otherwise noted. Typical values are at  $V_{24} = 24V$ ,  $V_5 = 5V$ ,  $V_L = 3.3V$ , and  $T_A = +25^\circ C$ , unless otherwise noted.) (Note 2)

PARAMETER	SYMBOL	CONDITIONS	MIN	TYP	MAX	UNITS
<b>C/Q, DO DRIVER</b>						
Driver Low-to-High Propagation Delay	$t_{PDLH}$	TXEN = High, <a href="#">Figure 1</a>		0.49	0.75	$\mu s$
Driver High-to-Low Propagation Delay	$t_{PDHL}$	TXEN = High, <a href="#">Figure 1</a>		0.61	0.95	$\mu s$
Driver Skew	$t_{DSKEW}$	$ t_{PDLH} - t_{PDHL} $ , TXEN = High, <a href="#">Figure 1</a>	-0.4		+0.4	$\mu s$
Driver Rise Time	$t_{RISE}$	TXEN = High, <a href="#">Figure 1</a>		0.54	1	$\mu s$
Driver Fall Time	$t_{FALL}$	TXEN = High, <a href="#">Figure 1</a>		0.63	1	$\mu s$
Driver Enable Time High	$t_{ENH}$	TXEN = High, <a href="#">Figure 3</a>		0.46	0.9	$\mu s$
Driver Enable Time Low	$t_{ENL}$	TXEN = High, <a href="#">Figure 2</a>		0.52	0.9	$\mu s$
Driver Disable Time High	$t_{DISH}$	TXEN = High, <a href="#">Figure 2</a>		2.1	3	$\mu s$
Driver Disable Time Low	$t_{DISL}$	TXEN = High, <a href="#">Figure 3</a>		1.5	3	$\mu s$
<b>C/Q, DI RECEIVER (<a href="#">Figure 4</a>)</b>						
C/Q Receiver Low-to-High Propagation Delay	$t_{PRLH\_CQ}$		0.825	1.56	2.25	$\mu s$
C/Q Receiver High-to-Low Propagation Delay	$t_{PRHL\_CQ}$		0.825	1.37	2.25	$\mu s$
C/Q Receiver Propagation Delay Skew	$t_{RSKEW}$	$t_{PRLH\_CQ} - t_{PRHL\_CQ}$		0.19		$\mu s$
DI Receiver Low-to-High Propagation Delay	$t_{PRLH\_DI}$		1.3	2.2	3.7	$\mu s$
DI Receiver High-to-Low Propagation Delay	$t_{PRHL\_DI}$		1.3	2.2	3.7	$\mu s$
<b>DRIVER CURRENT LIMITING</b>						
Blanking Time	$t_{ARBL}$	AR = High or low		500		$\mu s$
Autoretry Period	$t_{ARP}$	AR = High		50		ms
<b>WAKE-UP DETECTION (<a href="#">Figure 5</a>)</b>						
Wake-Up Input Minimum Pulse Width	$t_{WUMIN}$	$C_L = 3nF$	55	66	75	$\mu s$
Wake-Up Input Maximum Pulse Width	$t_{WUMAX}$		85	95	110	$\mu s$
$\overline{WU}$ Output Low Time	$t_{WUL}$	Valid wake-up condition on C/Q	100	200	300	$\mu s$

**Note 2:** All devices are 100% production tested at  $T_A = +25^\circ C$ . Limits over the operating temperature range are guaranteed by design.

**Note 3:** Not production tested. Guaranteed by design.

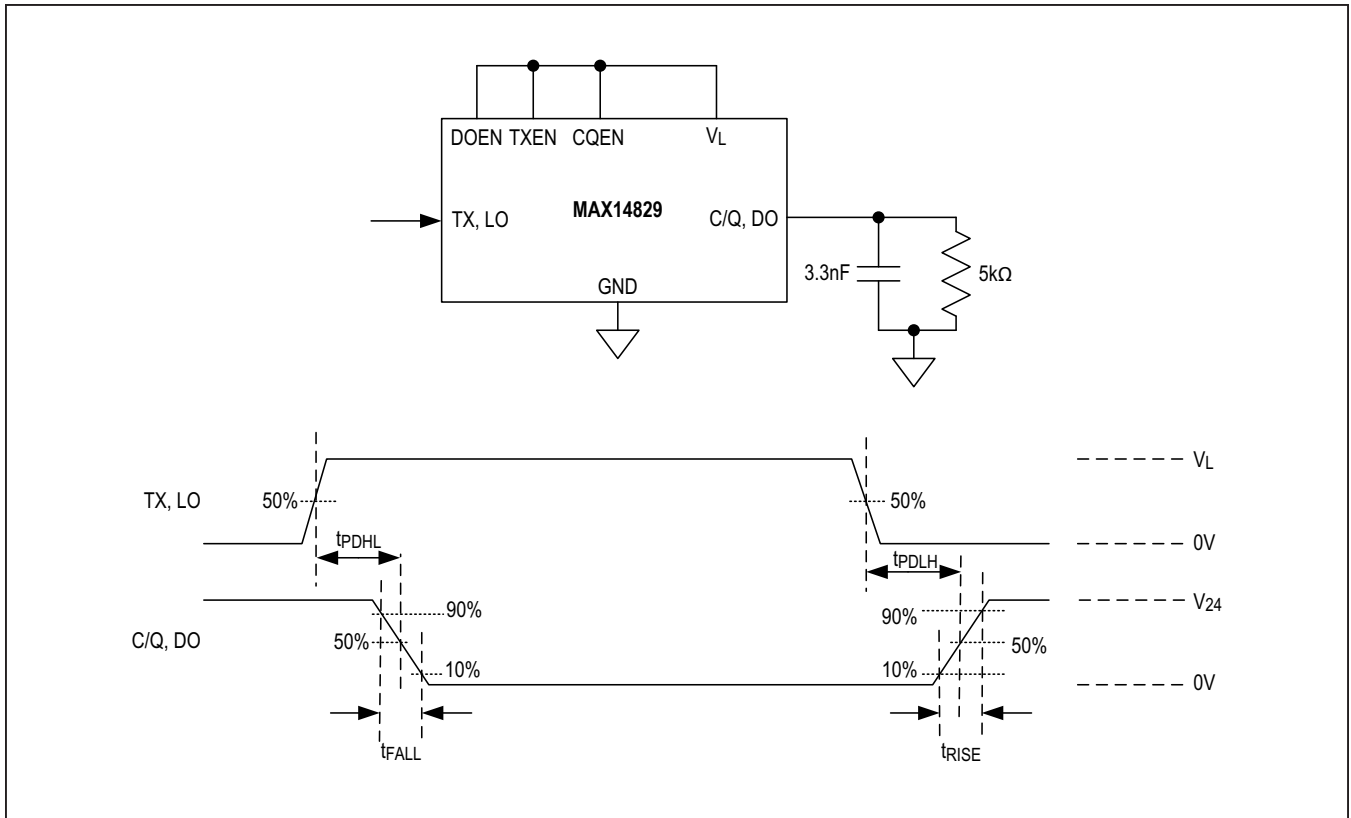

Figure 1. C/Q and LO Driver Propagation Delays and Rise/Fall Times

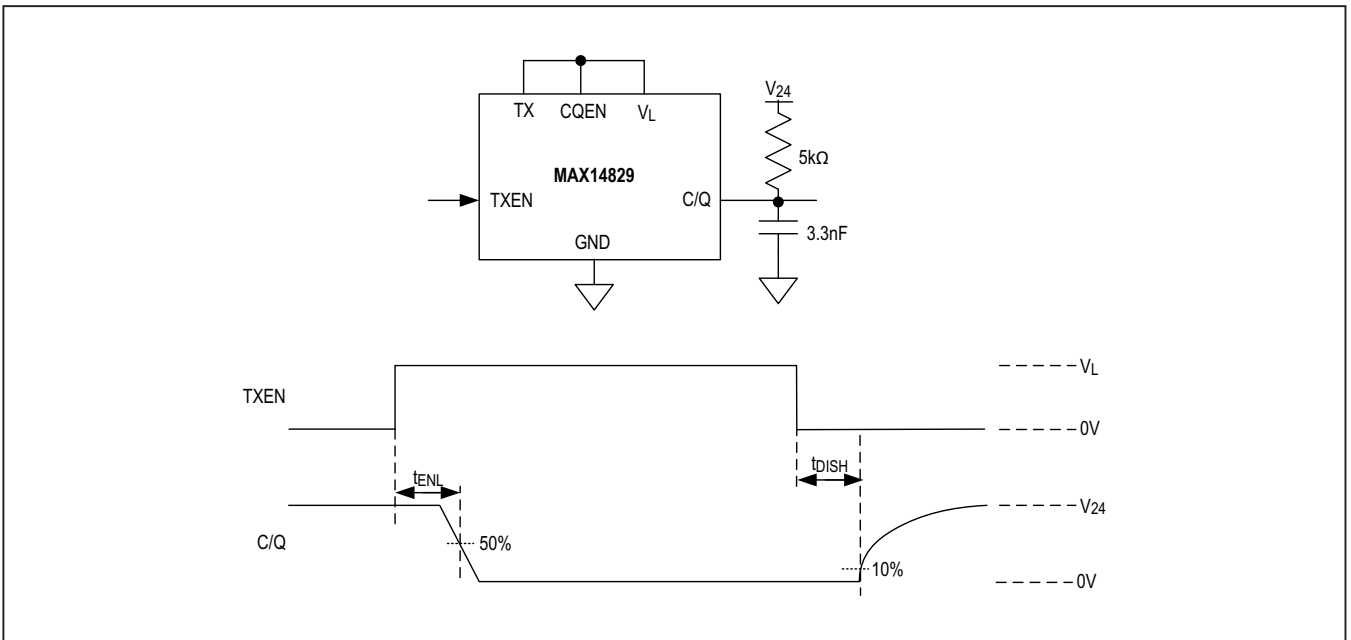

Figure 2. C/Q Driver Enable Low and Disable High Timing with External Pullup Resistor



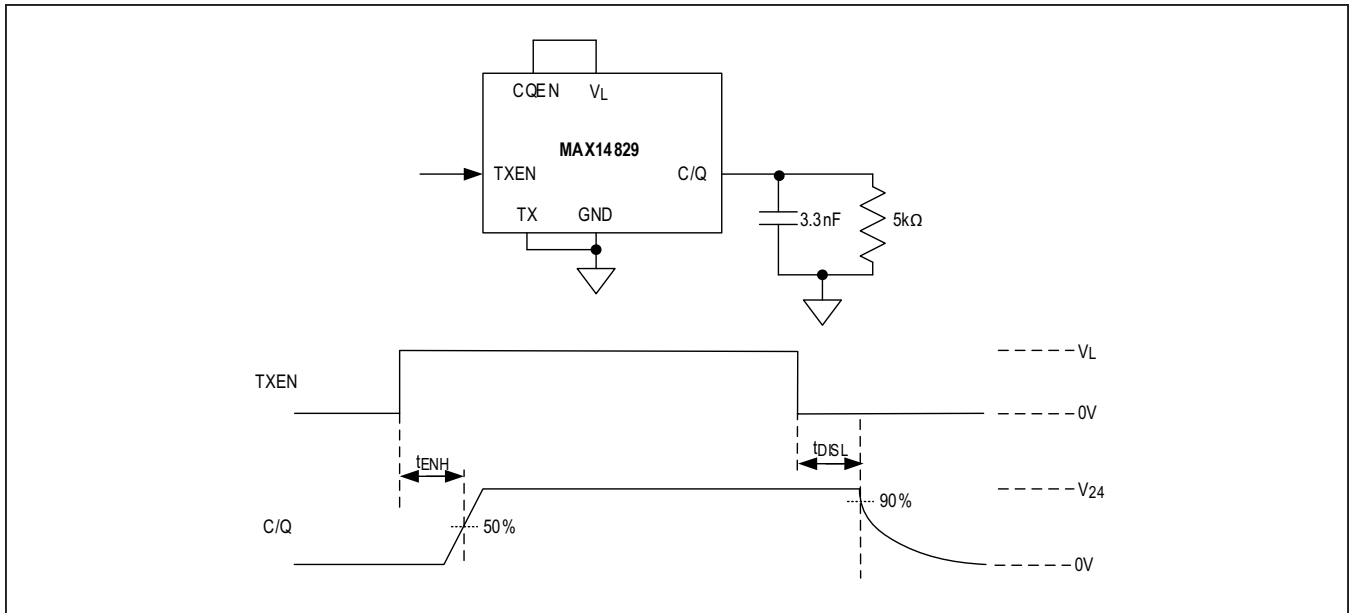

Figure 3. C/Q Driver Enable High and Disable Low Timing

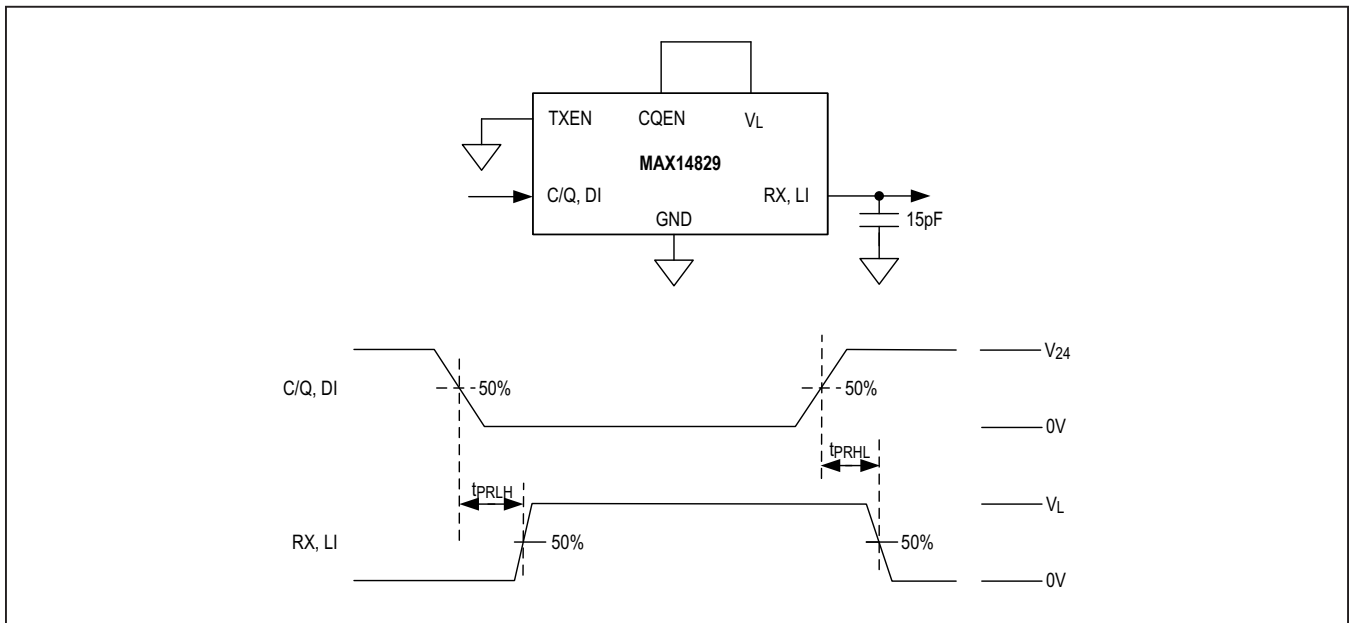
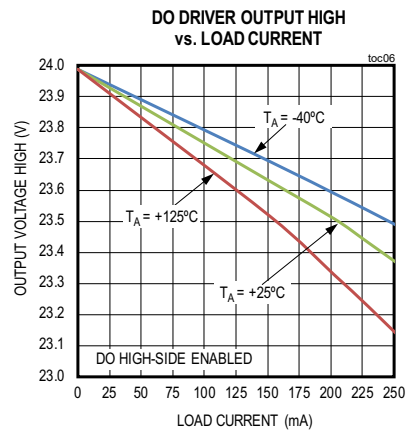
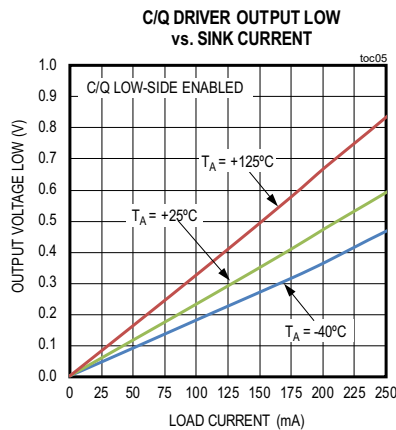
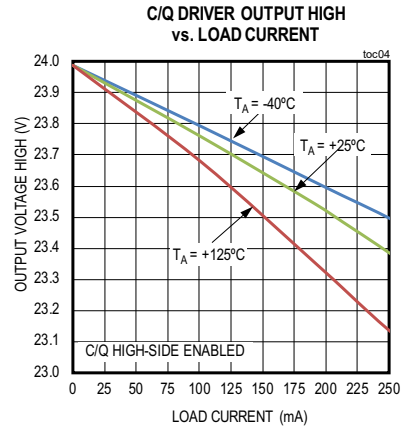
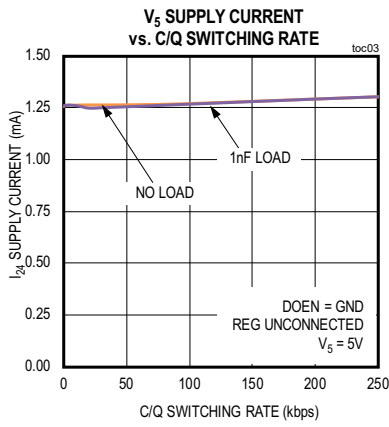
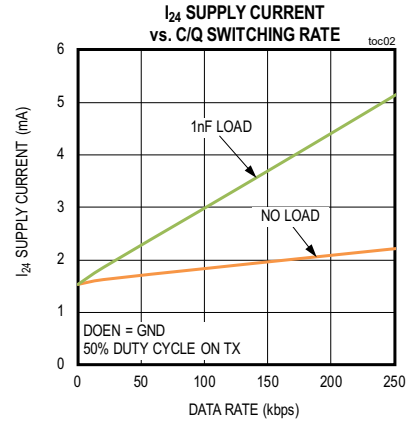
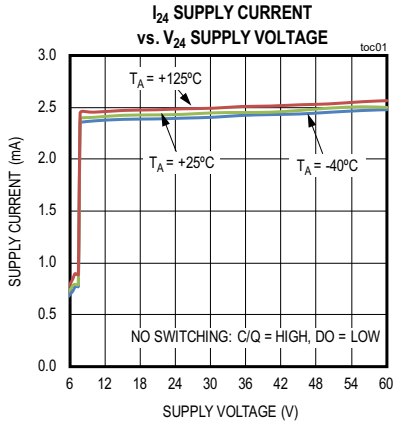

Figure 4. C/Q and DI Receiver Propagation Delays

Typical Operating Characteristics

( $V_{24} = 24V$ ,  $V_L = V_{33}$ , REG is shorted to  $V_5$ , CQEN =  $V_L$ , DOEN =  $V_L$ ,  $T_A = +25^\circ C$ , unless otherwise noted.)



Typical Operating Characteristics (continued)

( $V_{24} = 24V$ ,  $V_L = V_{33}$ , REG is shorted to  $V_5$ , CQEN =  $V_L$ , DOEN =  $V_L$ ,  $T_A = +25^\circ C$ , unless otherwise noted.)

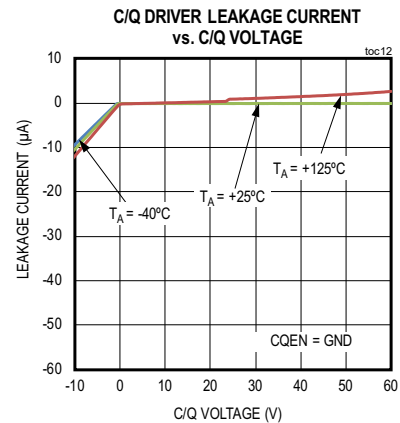
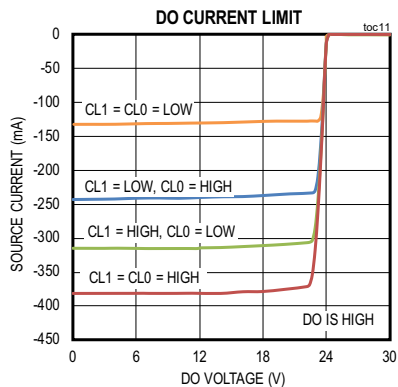
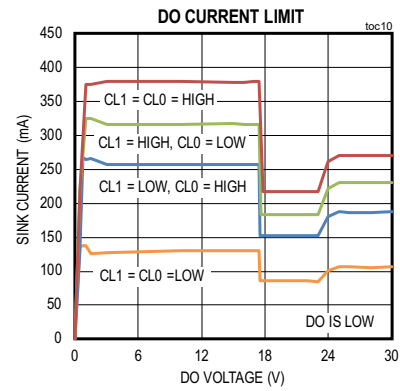
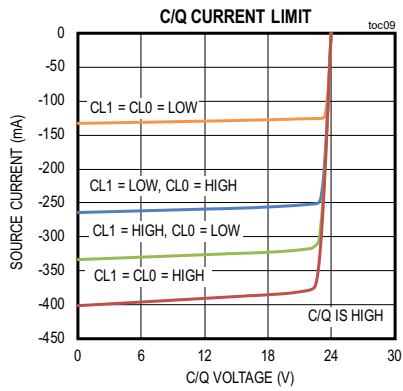
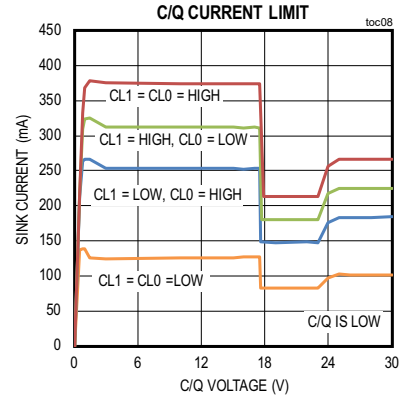
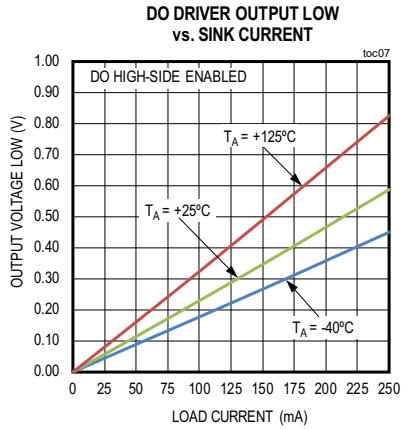

Typical Operating Characteristics (continued)

( $V_{24} = 24V$ ,  $V_L = V_{33}$ , REG is shorted to  $V_5$ , CQEN =  $V_L$ , DOEN =  $V_L$ ,  $T_A = +25^\circ C$ , unless otherwise noted.)

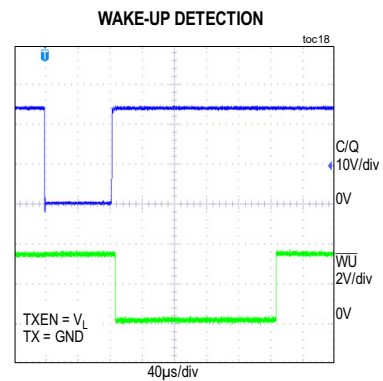
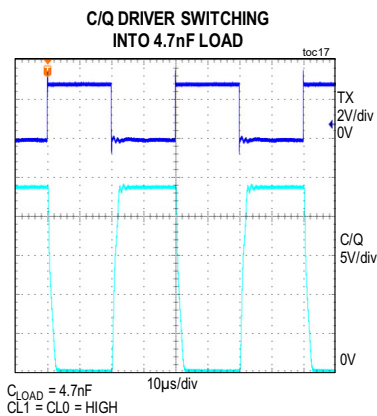
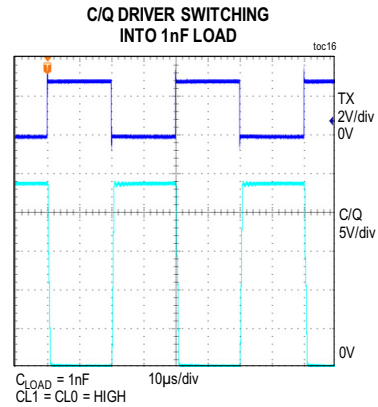
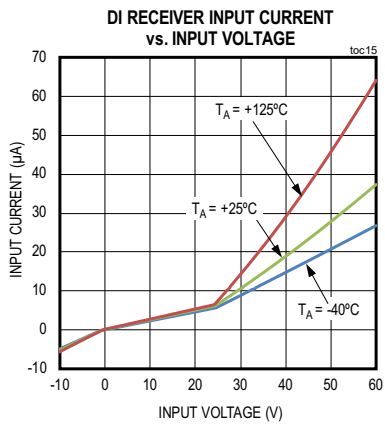
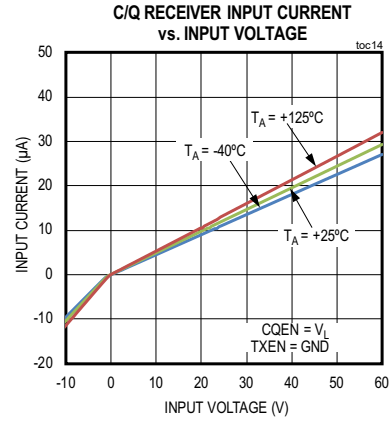
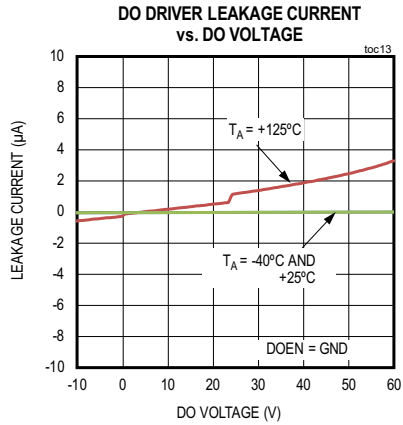

Typical Operating Characteristics

( $V_{24} = 24V$ ,  $V_L = V_{33}$ , REG is shorted to  $V_5$ , CQEN =  $V_L$ , DOEN =  $V_L$ ,  $T_A = +25^\circ C$ , unless otherwise noted.)

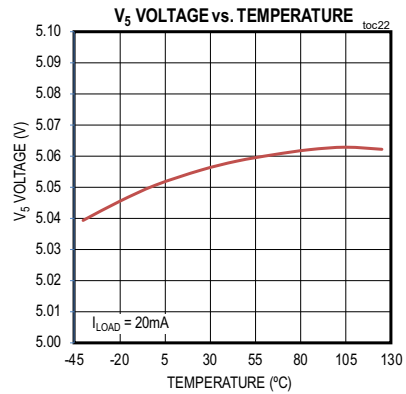
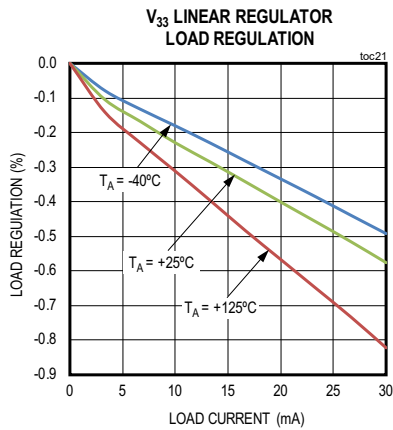
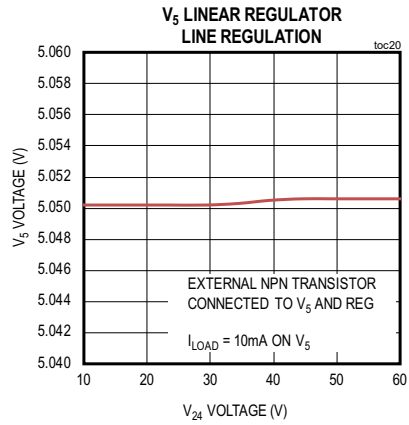
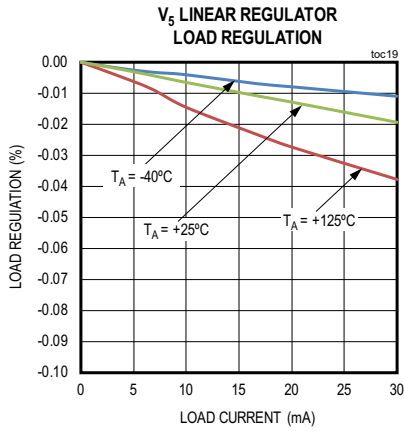

Pin Configuration

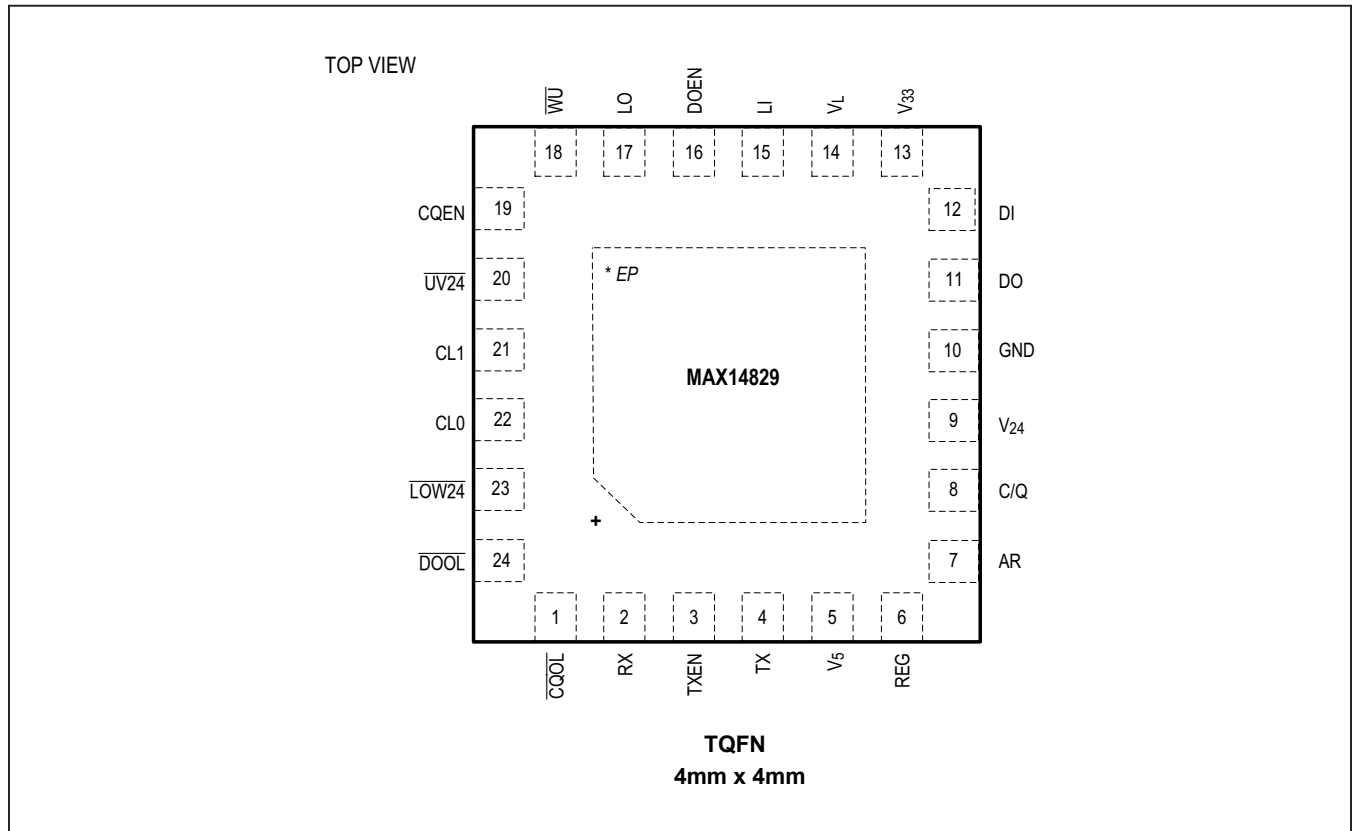

Pin Description

PIN	NAME	FUNCTION
1	$\overline{\text{CQOL}}$	Open-Drain C/Q Driver Fault Output. $\overline{\text{CQOL}}$ asserts low when a current overload condition is detected on C/Q for longer than the blanking time, or when the C/Q driver goes into driver thermal shutdown.
2	RX	C/Q Receiver Logic Output. RX is the logic inverse of C/Q. Connect RX to the RX input of a UART for IO-Link communication. RX is disabled and forced low when CQEN is low.
3	TXEN	C/Q Driver Enable Logic Input. Drive TXEN high to enable the C/Q driver. Drive TXEN low to disable the C/Q driver. Connect TXEN to the RTS output of a microcontroller for IO-Link communication.
4	TX	C/Q Driver Logic Input. C/Q is the logic inverse of the signal on TX when TXEN is high. Connect TX to the TX output of a UART for IO-Link communication.
5	V <sub>5</sub>	5V Linear Regulator Output/Supply Input. Bypass V <sub>5</sub> to GND with a 1μF capacitor. V <sub>5</sub> can be supplied by the internal 5V linear regulator or by an external regulator. To use the internal regulator, connect V <sub>5</sub> to REG, or to the emitter of an external NPN transistor. To bypass the internal regulator, leave REG unconnected and connect an external 5V supply directly to V <sub>5</sub> . 5V must be present on V <sub>5</sub> for normal operation.

## Pin Description (continued)

PIN	NAME	FUNCTION
6	REG	5V Regulator Control. To use the internal 5V linear regulator, connect REG to V <sub>5</sub> or connect REG to the base of an external NPN pass transistor. Leave REG unconnected and connect V <sub>5</sub> to an external 5V supply to bypass the internal regulator. 5V must be present on V <sub>5</sub> for normal operation.
7	AR	Autoretry Enable Logic Input. Drive AR high to enable autoretry overload cycling. Drive AR low to disable autoretry overload cycling.
8	C/Q	C/Q Transceiver Input/Output. Drive CQEN and TXEN high to enable the C/Q driver. The logic on the C/Q output is the logic inverse of the signal on TX. C/Q is high impedance when CQEN is low.
9	V <sub>24</sub>	Power Supply Input. Bypass V <sub>24</sub> to GND with a 0.1µF ceramic capacitor as close to the device as possible.
10	GND	Ground
11	DO	DO Driver Output. Drive DOEN high to enable the DO driver. DO is the logic inverse of the LO input. Drive DOEN low to disable the driver. DO is high impedance when DOEN is low.
12	DI	DI Receiver Input. LI is the logic inverse of the signal on the DI input. The DI receiver is always enabled.
13	V <sub>33</sub>	3.3V Linear Regulator Output. Bypass V <sub>33</sub> to GND with a 1µF capacitor as close to the IC as possible. V <sub>33</sub> is not required for normal operation. Connect V <sub>33</sub> to V <sub>5</sub> to disable the 3.3V linear regulator.
14	V <sub>L</sub>	Logic-Level Supply Input. V <sub>L</sub> defines the logic levels of the logic I/Os. Bypass V <sub>L</sub> to GND with a 0.1µF ceramic capacitor. Apply a voltage from 2.5V to 5.5V to V <sub>L</sub> for normal operation.
15	LI	DI Receiver Logic Output. LI is the logic inverse of the signal on the DI input. LI is always enabled.
16	DOEN	DO Driver Enable Logic Input. Drive DOEN high to enable the DO output. DO is high impedance when DOEN is low.
17	LO	DO Driver Logic Input. DO is the logic inverse of the signal on LO when DOEN is high.
18	$\overline{WU}$	Push-Pull Wake-Up Detection Output. $\overline{WU}$ asserts low for 200µs (typ) when a valid IO-Link wake-up is detected on the C/Q line.
19	CQEN	C/Q Driver Enable Logic Input. Drive CQEN high to enable C/Q driver. C/Q is high impedance when CQEN is low.
20	$\overline{UV24}$	Open-Drain V <sub>24</sub> Supply Undervoltage Indicator Output. $\overline{UV24}$ asserts low when V <sub>24</sub> falls below the 7.2V (typ) undervoltage lockout (UVLO) threshold. $\overline{UV24}$ deasserts when V <sub>24</sub> rises above the 7.8V (typ) UVLO threshold.
21	CL1	Driver Current Limit Setting Inputs. Connect CL0 and CL1 high or low to set the maximum load current for the C/Q and DO driver outputs. See the <a href="#">Table 3</a> and <a href="#">Electrical Characteristics</a> table for more information.
22	CL0	
23	$\overline{LOW24}$	Open-Drain V <sub>24</sub> Supply Warning Voltage Indicator Output. $\overline{LOW24}$ asserts low when V <sub>24</sub> falls below the 16.5V (typ) warning voltage threshold. $\overline{LOW24}$ deasserts when V <sub>24</sub> rises above 16.5V (typ).
24	$\overline{DOOL}$	Open-Drain DO Driver Fault Output. $\overline{DOOL}$ asserts low when a current overload condition is detected on DO for longer than the blanking time, or when the DO driver goes into driver thermal shutdown
EP	EP	Exposed pad. Connect to ground. Not intended as the main ground connection.

## Detailed Description

The MAX14829 is an industrial sensor output driver/IO-Link device transceiver. The IC integrates the high voltage functions commonly found in sensors, including two 24V line drivers (C/Q and DO) and two on-board linear regulators (LDOs). The integrated 3.3V and 5V LDOs provide the low-noise power needed for analog and logic supply rails.

The MAX14829 provides pins to configure and monitor device operation.

### 24V Interface (V<sub>24</sub>, C/Q, DO, DI, GND)

The MAX14829 features an IO-Link transceiver interface capable of operating with voltages up to 60V. This is the 24V interface and includes the C/Q input/output, the logic-level digital output (DO), the logic-level digital input (DI), the V<sub>24</sub> supply, and ground. The MAX14829 features switching drivers at C/Q and DO.

### C/Q and DO Configurable Drivers

The C/Q and DO drivers are push-pull ([Table 1](#) and [Table 2](#)). Toggle CQEN, TXEN, TX, DOEN, and LO to switch the C/Q and DO outputs and to operate C/Q and DO as NPN and PNP outputs.

### C/Q and DO Driver Enable/Disable

The C/Q driver is enabled/disabled with the TXEN and CQEN inputs. Drive CQEN high to enable the C/Q transceiver and drive TXEN high to enable the C/Q driver. C/Q is the logic inverse of the TX input.

The DO driver is enabled/disabled with the DOEN input. Drive DOEN high to enable the DO driver. DO is the logic inverse of the LO input.

**Table 1. C/Q Driver Control**

CQEN	TXEN	TX	C/Q DRIVER	
			LOW SIDE	HIGH SIDE
L	X	X	Driver and Receiver are disabled	
H	L	X	OFF	OFF
H	H	L	OFF	ON
H	H	H	ON	OFF

**Table 2. DO Control**

DOEN	LO	DO	
		LOW SIDE	HIGH SIDE
L	X	OFF	OFF
H	L	OFF	ON
H	H	ON	OFF

### C/Q and DO Driver Current Limit

The C/Q and DO drivers are optimized for driving large capacitive loads and dynamic impedances like incandescent lamps. The C/Q and DO driver current limit thresholds are selectable by setting the CL1 and CL0 pins ([Table 3](#)). When a load attempts to draw more current than the current limit threshold set by CL1 and CL0, the driver actively limits the load current so a higher current does not flow. If the overcurrent condition persists longer than the blanking time, the driver enters fault mode. See the [C/Q and DO Driver Fault Protection](#) section for more information.

### C/Q and DO Driver Fault Protection

The MAX14829 features two management functions to allow the C/Q and DO drivers to drive large loads: the blanking time, and autoretry.

Set AR high to enable autoretry cycling when an overcurrent condition occurs. In this mode, the driver is disabled after the 500 $\mu$ s (typ) blanking time and the driver fault indicator (CQOL or DOOL) asserts low. The driver is reenabled after the 50ms (typ) autoretry time. If the overcurrent condition is still present, the driver is again disabled after the blanking time and the cycle continues. The driver operates normally and the driver fault indicator deasserts within 50ms (typ) after the fault is removed.

Set AR low to disable autoretry cycling when an overcurrent occurs. In this mode, the driver fault indicator (CQOL or DOOL) asserts low if the overcurrent condition is present for longer than 500 $\mu$ s (typ). If the driver temperature exceeds the driver thermal shutdown threshold, the driver is disabled. When the driver temperature then falls by the 15 $^{\circ}$ C (typ) thermal shutdown hysteresis, the driver automatically is reenabled and the fault indicator pin deasserts. This thermal cycling repeats until the fault is removed.

### C/Q Receiver Output (RX)

RX is the output of the C/Q receiver. RX is the inverse logic of the C/Q input. The C/Q transceiver is disabled and RX is low when CQEN is driven low.

**Table 3. Driver Current Limit Setting**

CL1	CL0	C/Q AND DO CURRENT LIMIT (mA)
L	L	125
L	H	252
H	L	316
H	H	380



**C/Q and DI Receiver Threshold**

The IO-Link standard defines device operation with a sensor supply between 18V and 30V. Industrial sensors, however, commonly operate with supply voltages as low as 9V. The MAX14829 C/Q and DI receivers support operation with lower supply voltages by scaling the receiver thresholds when  $V_{24}$  is less than 18V ( $V_{24} < 18V$ ).

**Reverse-Polarity Protection**

The MAX14829 is protected against reverse-polarity connections on  $V_{24}$ , C/Q, DO, DI, and GND. Any combination of these pins can be connected to DC voltages up to 65V (max), resulting in a current flow of less than 1mA.

Ensure that the maximum voltage between any of these pins does not exceed the limits in the [Absolute Maximum Ratings](#) section.

**5V and 3.3V Linear Regulators**

The MAX14829 includes two internal regulators to generate 5V ( $V_5$ ) and 3.3V ( $V_{33}$ ).

The  $V_5$  regulator is capable of driving external loads up to 30mA, including the device and 3.3V LDO current consumption. To drive larger loads, use an external pass transistor to generate the required 5V. When using an external transistor, connect REG to the base of the transistor to regulate the voltage and connect  $V_5$  to the emitter ([Figure 7](#)).

When the internal 5V linear regulator is not used,  $V_5$  is the supply input for the internal analog and digital functions and must be supplied externally.

The MAX14829 requires a  $V_5$  supply for normal operation

The 3.3V regulator is capable of driving external loads up to 30mA.  $V_5$  and  $V_{33}$  are not protected against short circuits.

**Power Up**

The C/Q and DO driver outputs are high-impedance when  $V_{24}$ ,  $V_5$ , and  $V_L$  are below their respective undervoltage thresholds during power up.

The drivers are automatically disabled if any of the  $V_{24}$ ,  $V_5$ , or  $V_L$  supplies falls below its threshold.

**Low Voltage and Undervoltage Detection**

The device monitors the  $V_{24}$  supply for low-voltage and undervoltage lockout (UVLO) conditions.  $\overline{LOW24}$  asserts low when the  $V_{24}$  supply falls below the 16.5V (typ) warning threshold.

$\overline{UV24}$  asserts when the  $V_{24}$  supply falls below the 7.2V (typ) UVLO threshold. The C/Q and DO outputs are disabled, and the C/Q and DI receivers are disabled when  $V_{24}$  falls below the UVLO threshold.

$\overline{LOW24}$  and  $\overline{UV24}$  are open-drain outputs. Connect these pins to  $V_L$  with a 10k $\Omega$  resistor for normal operation. Low-voltage and UVLO monitoring cannot be disabled. Refer to [Table 6](#).

**Wake-Up Detection**

The MAX14829 detects an IO-Link wake-up condition on the C/Q line in all states (push-pull, NPN, and PNP). A wake-up condition is detected when the C/Q output is shorted for 80 $\mu$ s (typ).  $\overline{WU}$  pulses low for 200 $\mu$ s (typ) when the device detects a wake-up pulse on C/Q ([Figure 5](#)).

The device includes a wake-up detection algorithm to avoid false wake-up detection on C/Q. No wake-up event is detected within 500 $\mu$ s (typ) after the C/Q driver changes state.

**Table 6.  $V_{24}$  Voltage Detection ( $V_5 > V_{5UVLO}$ )**

$V_{24}$ VOLTAGE (V)	$\overline{UV24}$ OUTPUT	$\overline{LOW24}$ OUTPUT
> 16.5	High Impedance	High Impedance
> 7.8 and < 16.5	High Impedance	Low
< 7.2	Low	Low

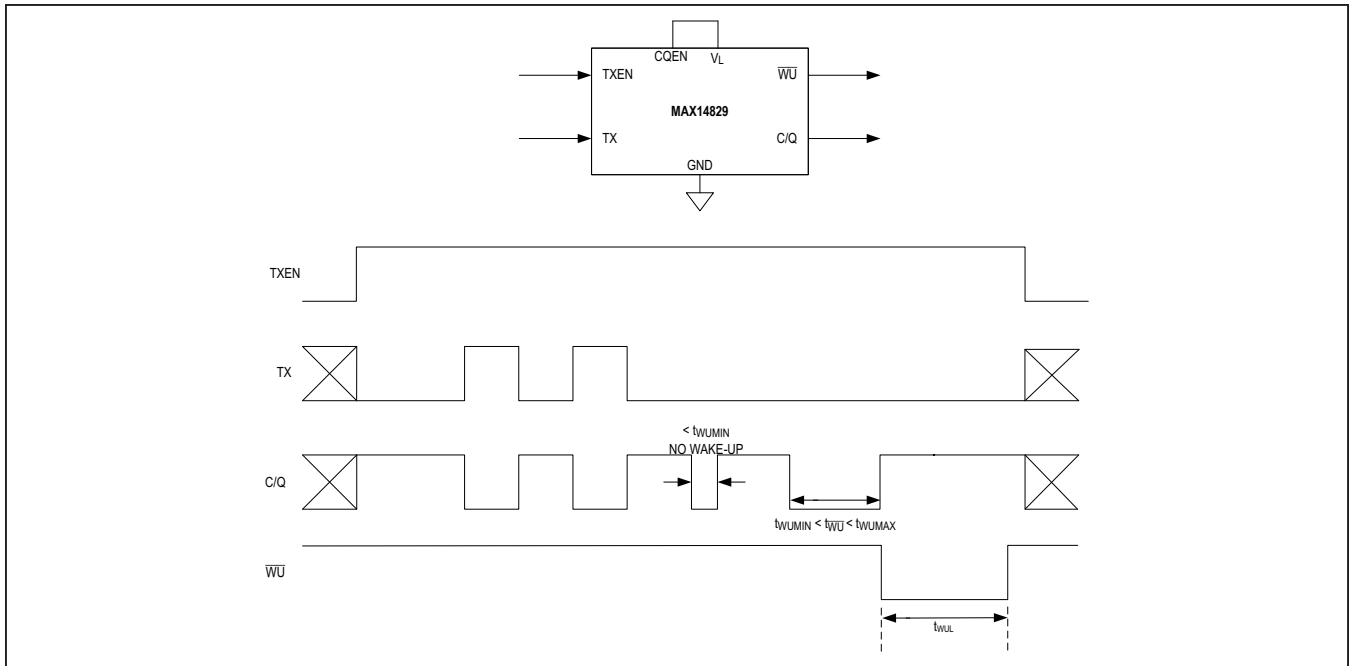

Figure 5. Wake-Up Detection Timing

**Thermal Protection and Considerations**

The internal LDOs can dissipate a large amount of power when driving external loads. Ensure that the LDO and driver power dissipation is less than the package can dissipate. Total power dissipation for the device is calculated using the following equation:

$$P_{TOTAL} = P_{C/Q} + P_{DO} + P_{V5} + P_{33} + P_{24}$$

where:

$P_{C/Q}$  = Power dissipated by the C/Q driver,

$P_{DO}$  = Power dissipated by the DO driver,

$P_{V5}$  and  $P_{V33}$  = Power dissipated by the LDOs,

$P_{24}$  = Quiescent power dissipated by the device,

Ensure that the total power dissipation is less than the limits listed in the [Absolute Maximum Ratings](#) section.

Use the following to calculate the power dissipation (in mW) due to the C/Q driver:

$$P_{C/Q} = [I_{C/Q(max)}]^2 \times R_O$$

where  $R_O$  driver on-resistance.

Calculate the internal power dissipation of the DO driver using the following equation:

$$P_{DO} = [I_{DO(max)}]^2 \times R_O$$

where  $R_O$  driver on-resistance.

Calculate the power dissipation in the 5V LDO,  $V_5$ , using the following equation:

$$P_5 = (V_{24} - V_5) \times I_5$$

where  $I_5$  includes the  $I_{33}$  current sourced from  $V_{33}$ .

Calculate the power dissipated in the 3.3V LDO,  $V_{33}$ , using the following equation:

$$P_{33} = 1.7V \times I_{LOAD33}$$

Calculate the quiescent power dissipation in the device using the following equation:

$$P_{24} = I_{24(max)} \times V_{24(max)}$$

**IC Thermal Shutdown**

The C/Q and DO drivers, and the  $V_5$  and  $V_{33}$  regulators are automatically switched off when the junction temperature exceeds the +170°C (typ) thermal shutdown threshold. Regulators are automatically switched on when the internal die temperature falls below the thermal shutdown threshold plus hysteresis.

## Applications Information

### Microcontroller Interfacing

The logic levels of the interface I/Os are defined by the logic level supply,  $V_L$ . Apply a voltage from 2.5V to 5.5V to  $V_L$  for normal operation. Logic outputs are supplied by  $V_L$ . Connect a UART to TXEN, TX, and RX for IO-Link communication.

### Transient Protection

Inductive load switching, ESD, bursts, and surges create high transient voltages.  $V_{24}$ , C/Q, DI, and DO should be protected against high overvoltage and undervoltage transients. Positive voltage transients on  $V_{24}$ , C/Q, DO, and DI must be limited to +70V relative to GND. Negative voltage transients must be limited to -70V relative to  $V_{24}$ . Use protection diodes on C/Q, DO, and DI as shown in [Figure 6](#).

For the standard ESD and burst protection required by the IO-Link specification, small package TVS can be used (like the uClamp3603T or the SPT01-335). If higher level surge ratings need to be achieved (IEC 61000-4-5  $\pm 1\text{kV}/42\Omega$ ), PDF3-32 or SMM4F33 TVS protectors can also be used.

### Improved EFT/Burst Resilience

To improve data errors during EFT/burst testing, Maxim recommends adding a 390pF (typ) capacitor from C/Q to GND and from C/Q to  $V_{24}$ .

### Using an External Transistor with the 5V Regulator

The internal 5V regulator ( $V_5$ ) can provide up to 30mA of total load current (including any load on the  $V_{33}$  regulator) when  $V_5$  is connected to REG. To achieve larger load currents or to shunt power dissipation away from the MAX14829, an external NPN transistor can be connected as shown in [Figure 7](#).

Select an NPN transistor with high  $V_{CE}$  voltage to support the max L+ supply voltage. In order to protect the NPN transistor against reverse polarity of the L+/L- supply terminals, connect a silicon or a Schottky diode in series with the NPN transistor collector that has a reverse voltage capability large enough for reverse connected L+/L-. A 1 $\mu$ F capacitor on  $V_5$  is required for stability.

### Using a Step-Down Regulator to Power $V_5$

To decrease power dissipation in the MAX14829,  $V_5$  can be powered by an external step-down regulator. Leave REG unconnected and connect the output of the external regulator to the  $V_5$  input ([Figure 8](#)).

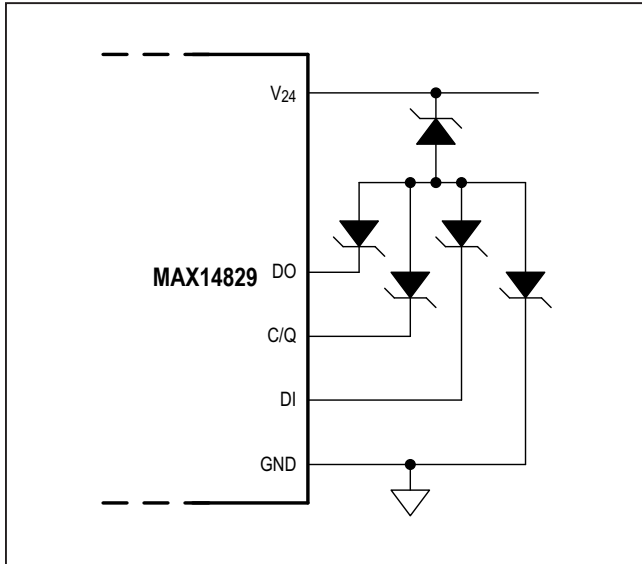

Figure 6. MAX14829 Operating Circuit with TVS Protection

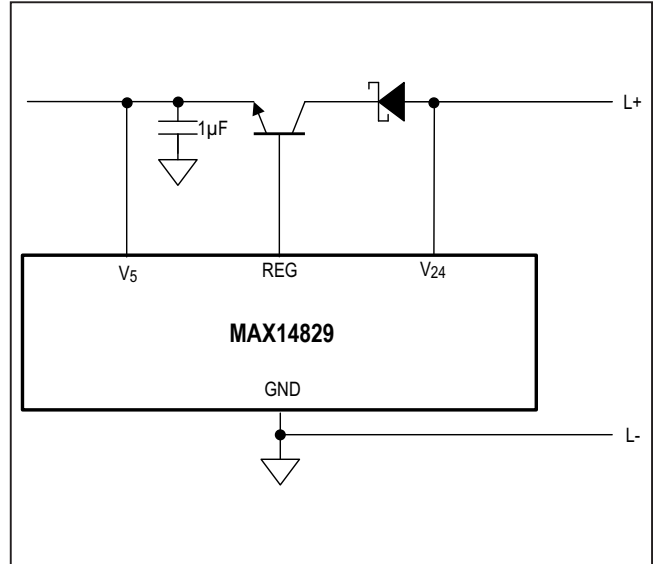

Figure 7. Using an External NPN Transistor with the 5V Regulator

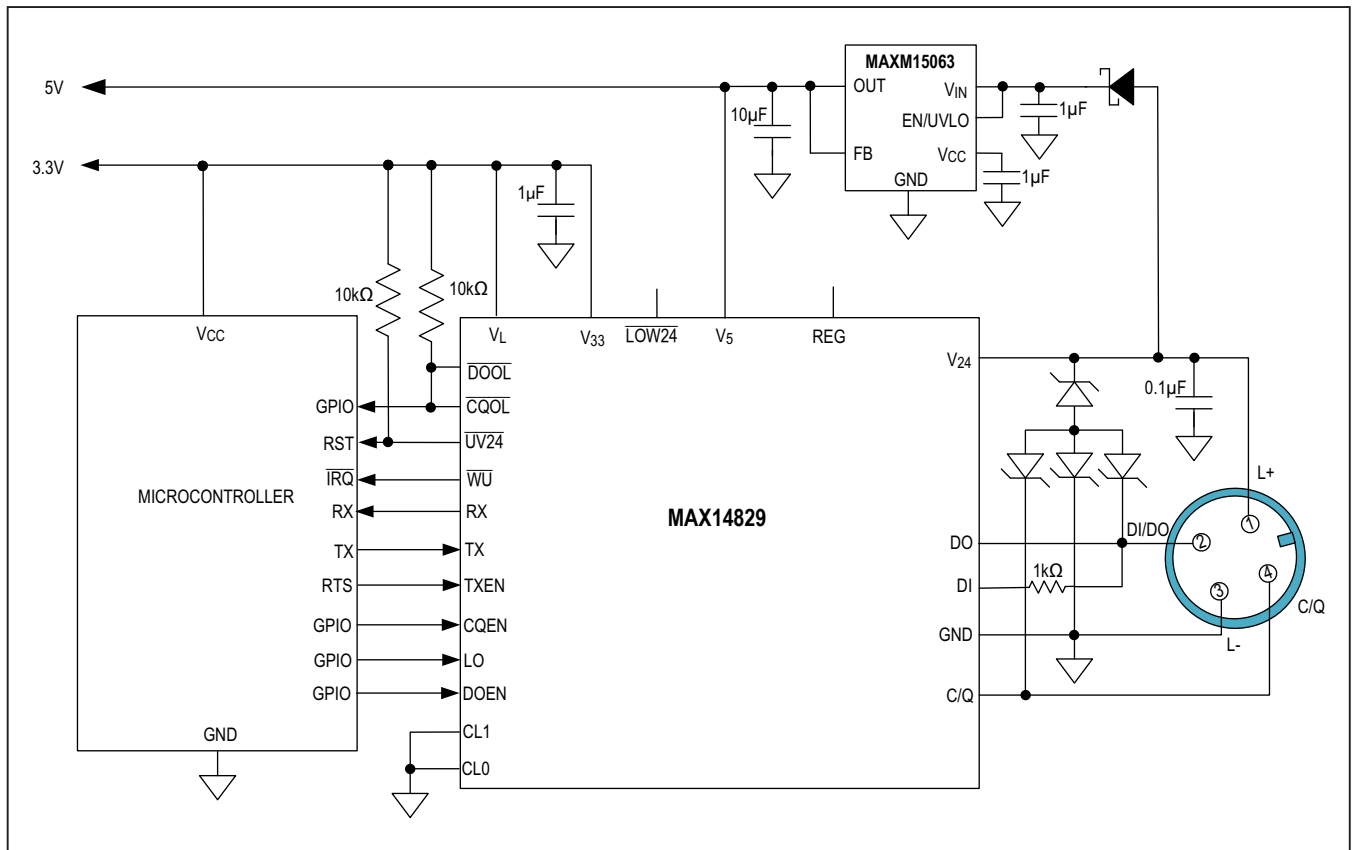

Figure 8. Using an External Step-Down with the 5V Regulator

## Ordering Information

PART	TEMP RANGE	PIN-PACKAGE
MAX14829ATG+	-40°C to +125°C	24 TQFN-EP*
MAX14829ATG+T	-40°C to +125°C	24 TQFN-EP*

+Denotes a lead(Pb)-free/RoHS-compliant package.

\*EP = Exposed pad.

T = Tape & Reel.

## Chip Information

PROCESS: BiCMOS

## Revision History

REVISION NUMBER	REVISION DATE	DESCRIPTION	PAGES CHANGED
0	9/19	Initial release	—

For pricing, delivery, and ordering information, please visit Maxim Integrated's online storefront at <https://www.maximintegrated.com/en/storefront/storefront.html>.

*Maxim Integrated cannot assume responsibility for use of any circuitry other than circuitry entirely embodied in a Maxim Integrated product. No circuit patent licenses are implied. Maxim Integrated reserves the right to change the circuitry and specifications without notice at any time. The parametric values (min and max limits) shown in the Electrical Characteristics table are guaranteed. Other parametric values quoted in this data sheet are provided for guidance.*