

CN Information

Change Notice Information Announcement

Customer Care Center: 1(888)778-2733 or email: ccc@schneider-electric.com



GREEN Flag Notice

Time to Product Change: Effective Immediately

Note: The green flag notification indicates an **insignificant** change in form, fit, or function of an offer.

Product Name(s): TeSys GV2L & GV3L

Customer Support No.: 1(888)778-2733

Product Line Description: Manual Starter & Protector

Document Issued: 11/19/2019

Description of Change:
 There is new certification for offers TeSys GV2L and GV3L which has an impact on the product markings (UL&CSA logos and performances), individual box markings, and instruction sheets.
Product Certifications Impacted:
 UL for Manual Motor Controllers -
 1) Model GV2, followed by L or LE, followed by 03, 04, 05, 06, 07, 08, 10, 14, 16, 20 or 22.
 2) Model GV3L, followed by 25,32,40,50,65 or 73 may be followed by 6 or 1.
 CSA for Manual Motor Controllers -
 1) Model GV3L, open type, 3 pole-3 ph, with non-adjustable thermal and magnetic trip, Cat. Nos. GV3L25 to GV3L73 for use in conjunction with certified overload relay.

Product Photos

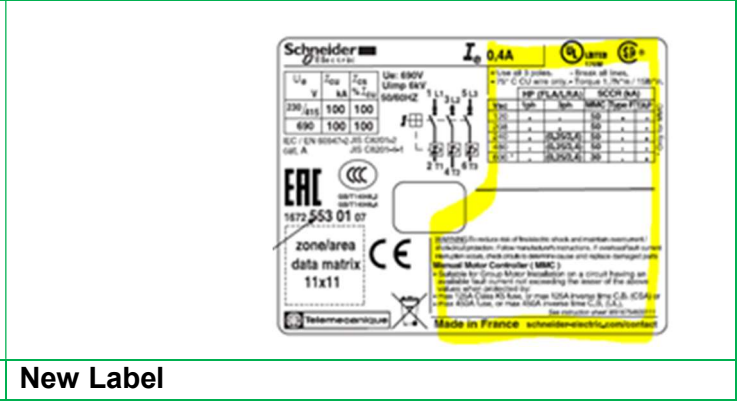
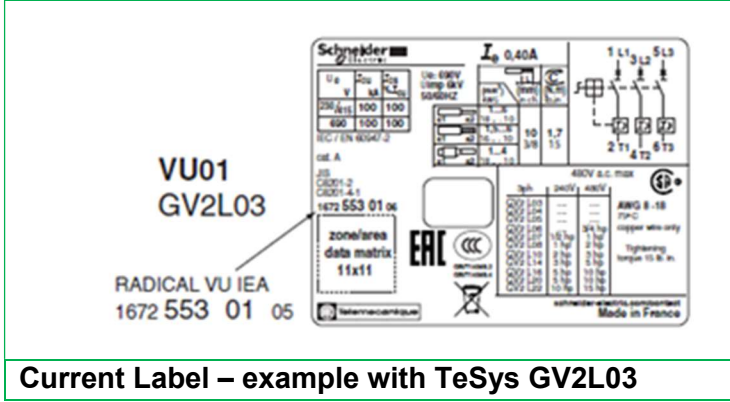

Critical Dates

Product Change Takes Effect: November 2019

Availability date of new product: November 2019

Transition Tools (as required):
 See "TeSys GV2L..Instruction Sheet.pdf" and "TeSys GV3L..Instruction Sheet.pdf" for instruction documents.

CN Information

Change Notice Information Announcement

Customer Care Center: 1(888)778-2733 or email: ccc@schneider-electric.com



Additional Photos (as required)

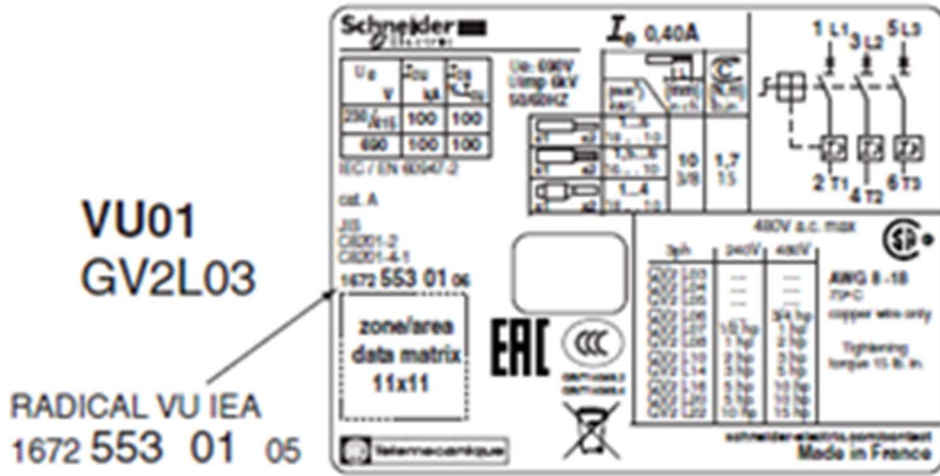

Previous Label

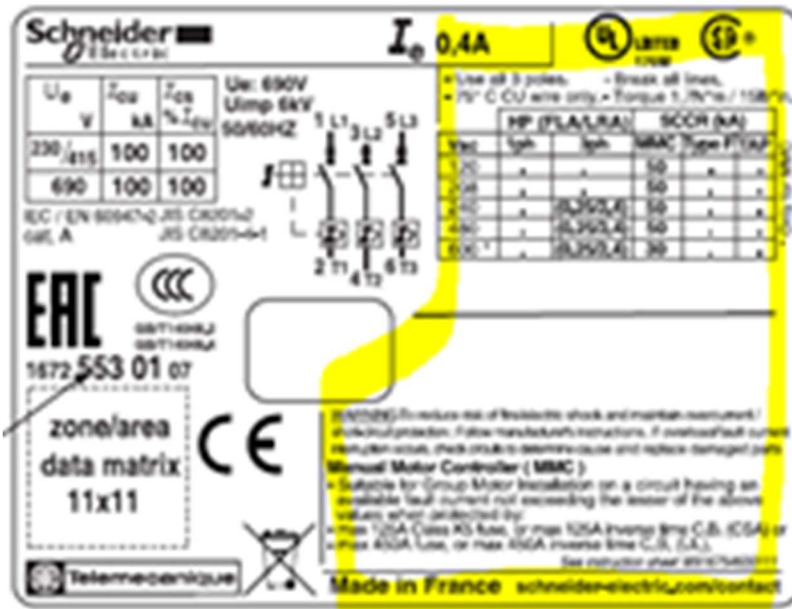

New Label