

Keysight Technologies

The Advantage of Universal Inputs in Data Acquisition Systems

Application Brief

Test Challenges:

- Measure multiple sensors and signal types



Unlocking Measurement Insights

Overview

Not all DAQs can handle any input. If your inputs are incompatible with your DAC you'll have to resort to costly, complicated signal conditioning circuitry. Having universal inputs on your DAQ will allow you to use your existing sensors and update your system as your needs change with minimal investment. This application brief will guide you through design considerations, system considerations, and tips to speed up your automated testing.

See our test challenges below to learn how the Keysight Technologies 34970A and 34972A DAQ systems can provide you the versatility, powerful functionality and cost-effectiveness you need to design modern test systems. Also, gain additional insight into a range of design considerations, comparisons to PXI systems and test optimizations; all useful information, regardless of whether you are developing a new system or simply trying to optimize a 34970A/34972A DAQ system.

Creating a thermal profile of a DUT

You want to create a thermal profile of your Device-Under-Test (DUT). The temperature range is relatively narrow and the fastest rate at which you will sample the data is about 1 sample every 5 seconds. Accuracy is the most important parameter in your measurement. Consequently, you've decided to use a Resistance Temperature Detector (RTD) because it provides the most accurate temperature measurements. To eliminate lead resistance errors, you need a 4-wire measurement that compensates for lead resistance. The 34970A and 34972A DAQ systems feature a built-in Digital Multimeter (DMM) that work easily with RTD arrays. With built-in signal conditioning, the Keysight Technologies DAQ systems can simplify your DAQ wiring and electronics. You can even use a software program to gather and visualize your data.

Making mixed-signal measurements

Mixed-signal measurements are a common requirement for any test system. In one DAQ system alone, you might measure temperature, flow pressure and high voltages. Making these measurements accurately and efficiently requires a versatile and powerful DAQ system. Using the versatile 34970A DAQ system, or even the newer 34972A DAQ system, you can easily scan high voltage (up to 300 V) points and have a combination of different low voltage points, sensitive transducers and RF signals—all in the same system.

A cost-effective solution

Often developers use PXI or VXI when designing DAQ systems. However, if you are starting a new system design, you should be aware of the true costs associated with PXI as compared to a 34970A/34972A DAQ system.

With an existing PXI/VXI system, the only consideration is the module cost, which can range anywhere from \$500 to greater than \$2000 USD. When starting a new system design, the cost of the mainframe, cables, interface hardware, and software must be taken into account.

To compare the cost between the two scenarios, consider a configuration with 120 single-ended channels. A 34972A with this configuration will cost less than \$4,000 USD, including the I/O connection to a PC via a readily available USB or LAN cable. In contrast, a new PXI switch system with the same configuration will easily exceed \$6,000 USD, and require the purchase of a card cage, MXI-4 cable and an I/O card for the PC, in addition to switch cards for the 120 single-ended channels.

Overcoming the I/O challenge

The number of instruments used in a test system often places a heavy burden on the digital input and output (I/O) between the system computer, usually a PC, and the test equipment. One of the best ways to cope with a high volume of I/O traffic—commands, status messages, and test data—is to employ LAN or USB technology. Both are fast, open and low-cost solutions for system I/O and should be considered when designing a new test system. USB and LAN are standard on the 34972A DAQ system.

For systems locked into using GPIB or legacy RS-232, the 34970A DAQ system offers its full support. GPIB and RS-232 are less common on newer systems due to the low cost-of-entry for LAN and USB. None the less, GPIB is a proven I/O standard and has been in use in industrial systems for over 20 years. RS-232 is still in use for low-cost controllers that do not have the other I/Os mentioned.

DAQ measurements with a DMM

Data loggers like the Keysight 34970A and 34972A DAQ systems use highly accurate, integrating analog-to-digital (A/D) voltmeters to measure the various inputs routed to them via multiplexer cards. The 34970A and 34972A, for example, employ a 6½-digit DMM with a noise floor equivalent to the Effective Number of Bits (ENOB) to 1 bit out of 24 (Figure 1).



Figure 1. Shown here is the 34970A DAQ system with built-in 6½ digit DMM.

If you do not need a full 6½ digits (24 bits) of resolution, you can select a shorter integration time, although the noise rejection may suffer as a result. Most integrated A/D voltmeters also have an auto-zero function that measures an internal short between each measurement to compensate for offset drift in the A/D.

Because the 34970A and 34972A feature a built-in DMM, you gain all of the measurement benefits associated with the 6½-digit DMM, including the ability to measure up to 300 V and down to microvolts. This wide voltage range allows you to mix very sensitive transducers with very high voltage data points.

Since a DMM has the intrinsic ability to make 4-wire-ohms measurements, it can accurately measure RTD sensors (Figure 2). Using a current source along with a remotely sensed digital voltmeter eliminates the additional lead resistance in your measurement. Since no current flows through the voltage sense leads, there is no IR drop in the leads and thus, no lead resistance error in the measurement.

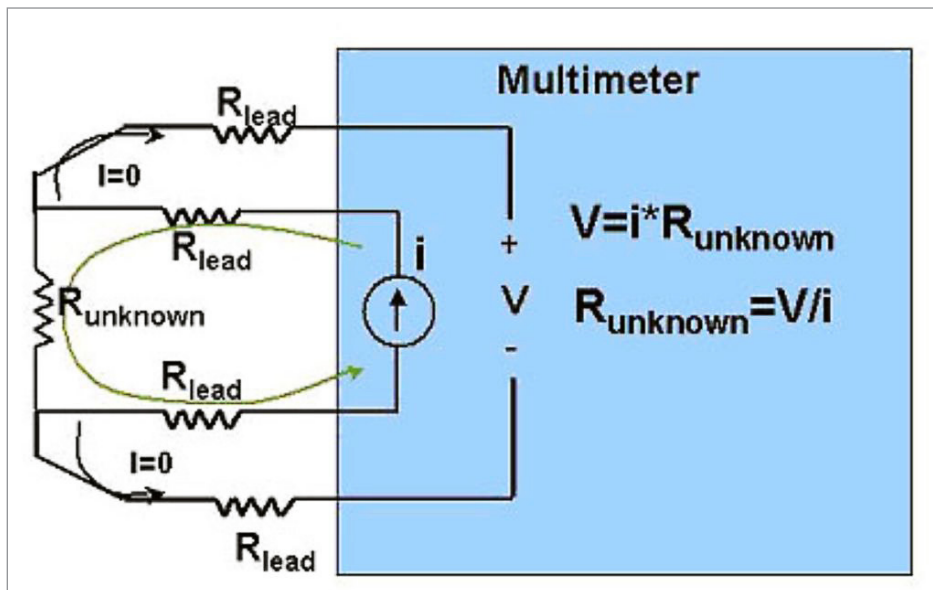

Figure 2. A 4-wire ohms diagram is illustrated in this graphic.

The 34970A/34972A modules can switch from microvolts to 300 volts, DC to 2 GHz, and with densities as high as 120 single-ended channels or 96 matrix cross-points per frame. Simple control capabilities like analog outputs, open collector digital outputs and isolated Form-C relays for controlling higher-powered devices are also available. Built in signal conditioning simplifies conversion electronics and allows for higher accuracy and resolution measurements.

Measurement tip

To reduce measurement errors:

- Group all similar measurements together. For example, put all thermocouple measurements in adjacent channels, then place DCV inputs together, next place all ACV inputs together, and so on, as this will minimize time-consuming function changes.
- If possible, match input levels so that time-consuming range changes are minimized. For example, group all DCV measurements on the 1-V range.
- To eliminate range and function changes completely, convert all inputs to a single type, like DC volts, and ensure they can be read on the same range, such as the 10-volt range.
- Terminate all 4-20 mA loops in 250 ohms, converting current into voltage.

Measurement tip

Concerned with AC measurements?

Measuring Root Mean Square (RMS) values is more complicated than it first appears, so why do we bother? The answer is simple. True RMS is the only AC voltage reading that does not depend on the shape of the signal. In fact, often times it is the most useful measurement for real-world waveforms. If accurate RMS measurements are important to you and you are likely to run into pulse trains and other complicated signals, then a true RMS meter is the only solution. The 34970A/34972A offers the same True RMS measurements found in the best selling 34465A DMM.

Optimizing measurement and transactional speed

If accuracy is secondary to measurement and transactional speed, here are a few points to consider:

Transactional speed:

The data acquisition system also spends time parsing commands, controlling auto-ranging, updating the display, and in the case of thermocouple measurements, measuring thermocouple reference junctions and converting thermocouple voltage readings into temperature. These activities all take time. By carefully considering each of these functions, and eliminating those that won't affect required system accuracy, you can substantially improve measurement time.

If you are using LAN and need to reduce the transaction latency, you can optimize LAN transactions by concatenating multiple commands in the same string. For example, sending "ROUT:CLOS (@1001);;ROUT:OPEN (@1001);;ROUT:OPEN?(@1001)," will send three commands in a single string to the DAQ system. Rather than using three different transactions, which include transaction time and latency, sending only one single transactional command can save you 50% of the transaction time.

Measurement speed:

If you are trying to optimize your measurement speed, there are a number of system overhead settings that you can change. By default, the 34970A/34972A is made to be usable from the front panel and is designed to be user friendly and readable. To get faster readings, simply turn off the display to reduce the processing overhead required to drive the display and buttons.

Choosing the Right Multiplexer

Multiplexers consist of multiple switches combined so that any one channel is connected to a common output at any given time (Figure 3). Scan speed is affected by the type of switches used in the multiplexer. Electro-mechanical armature relays are rugged and can handle relatively large voltages and currents. Armature relays handle the highest magnitudes, but are relatively slow and only able to switch at a rate of 60 channels per second. Reed relays carry less current, but are faster and are often used in data acquisition scanners. The scanning rate for reed multiplexers is 250 channels per second for the 34970A/34972A.

Summary

Using a versatile and powerful DAQ system like the 34970A or 34972A, you can easily and cost-effectively design automated tests. A built-in DMM enables the 34970A/34972A to measure the various inputs routed to them via multiplexer cards. Following a few simple measurement tips users can optimize the instruments for throughput, scanning speed, or accuracy. Thanks to the 34970A/34972A DAQ system, designing automated tests has never been easier.

To learn more, go to www.Keysight.com/find/daq

Measurement tip

To increase your reading speed on the 34970A/34972A:

- If the environment around your data logger is relatively stable, turn auto-zero off.
- Program the DMM range directly rather than leaving the DMM in auto-range mode.
- Set the correct integration time. Integrating over at least one Power Line Cycle (PLC) will reduce the effect of power-line related noise, but limits the measurement speed to 50 or 60 readings per second.
- Turn off the front panel display and keyboard.
- Use constant current sources to measure resistance, which gives you a voltage measurement.
- Measure thermocouple reference junctions less frequently.
- Convert thermocouple voltage measurements to temperature in your computer rather than in the DAQ system itself.

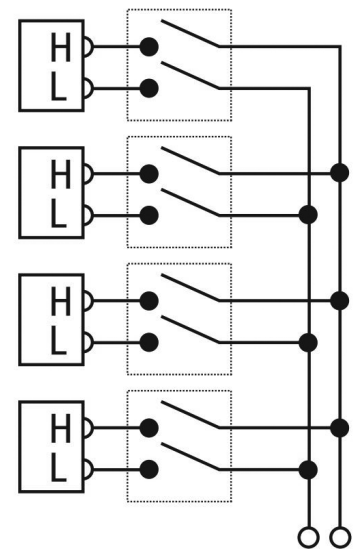
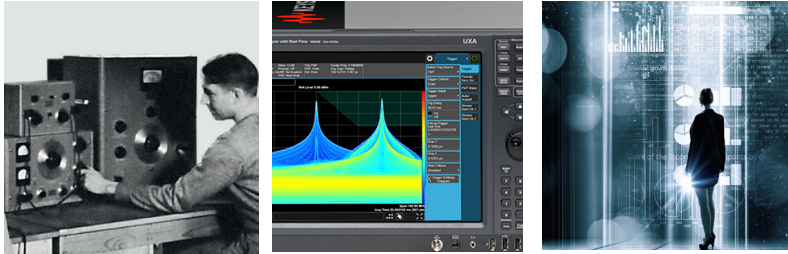

Figure 3. Shown here is a 2-wire, 4:1 MUX.

Evolving Since 1939

Our unique combination of hardware, software, services, and people can help you reach your next breakthrough. We are unlocking the future of technology.
From Hewlett-Packard to Agilent to Keysight.



For more information on Keysight Technologies' products, applications or services, please contact your local Keysight office. The complete list is available at: www.keysight.com/find/contactus

Americas

Canada	(877) 894 4414
Brazil	55 11 3351 7010
Mexico	001 800 254 2440
United States	(800) 829 4444

Asia Pacific

Australia	1 800 629 485
China	800 810 0189
Hong Kong	800 938 693
India	1 800 11 2626
Japan	0120 (421) 345
Korea	080 769 0800
Malaysia	1 800 888 848
Singapore	1 800 375 8100
Taiwan	0800 047 866
Other AP Countries	(65) 6375 8100

Europe & Middle East

Austria	0800 001122
Belgium	0800 58580
Finland	0800 523252
France	0805 980333
Germany	0800 6270999
Ireland	1800 832700
Israel	1 809 343051
Italy	800 599100
Luxembourg	+32 800 58580
Netherlands	0800 0233200
Russia	8800 5009286
Spain	800 000154
Sweden	0200 882255
Switzerland	0800 805353
	Opt. 1 (DE)
	Opt. 2 (FR)
	Opt. 3 (IT)
United Kingdom	0800 0260637

For other unlisted countries:
www.keysight.com/find/contactus
(BP-9-7-17)

DEKRA Certified
ISO 9001 Quality Management System

www.keysight.com/go/quality
Keysight Technologies, Inc.
DEKRA Certified ISO 9001:2015
Quality Management System

This information is subject to change without notice.
© Keysight Technologies, 2014 - 2017
Published in USA, November 29, 2017
5992-0100EN
www.keysight.com

myKeysight

myKeysight

www.keysight.com/find/mykeysight

A personalized view into the information most relevant to you.

http://www.keysight.com/find/emt_product_registration

Register your products to get up-to-date product information and find warranty information.

KEYSIGHT SERVICES
Accelerate Technology Adoption.
Lower costs.

Keysight Services

www.keysight.com/find/service

Keysight Services can help from acquisition to renewal across your instrument's lifecycle. Our comprehensive service offerings—one-stop calibration, repair, asset management, technology refresh, consulting, training and more—helps you improve product quality and lower costs.

Keysight Assurance Plans

www.keysight.com/find/AssurancePlans

Up to ten years of protection and no budgetary surprises to ensure your instruments are operating to specification, so you can rely on accurate measurements.

Keysight Channel Partners

www.keysight.com/find/channelpartners

Get the best of both worlds: Keysight's measurement expertise and product breadth, combined with channel partner convenience.



Unlocking Measurement Insights