

DESIGNED & DIMENSIONED
IN MILLIMETERS [INCHES]

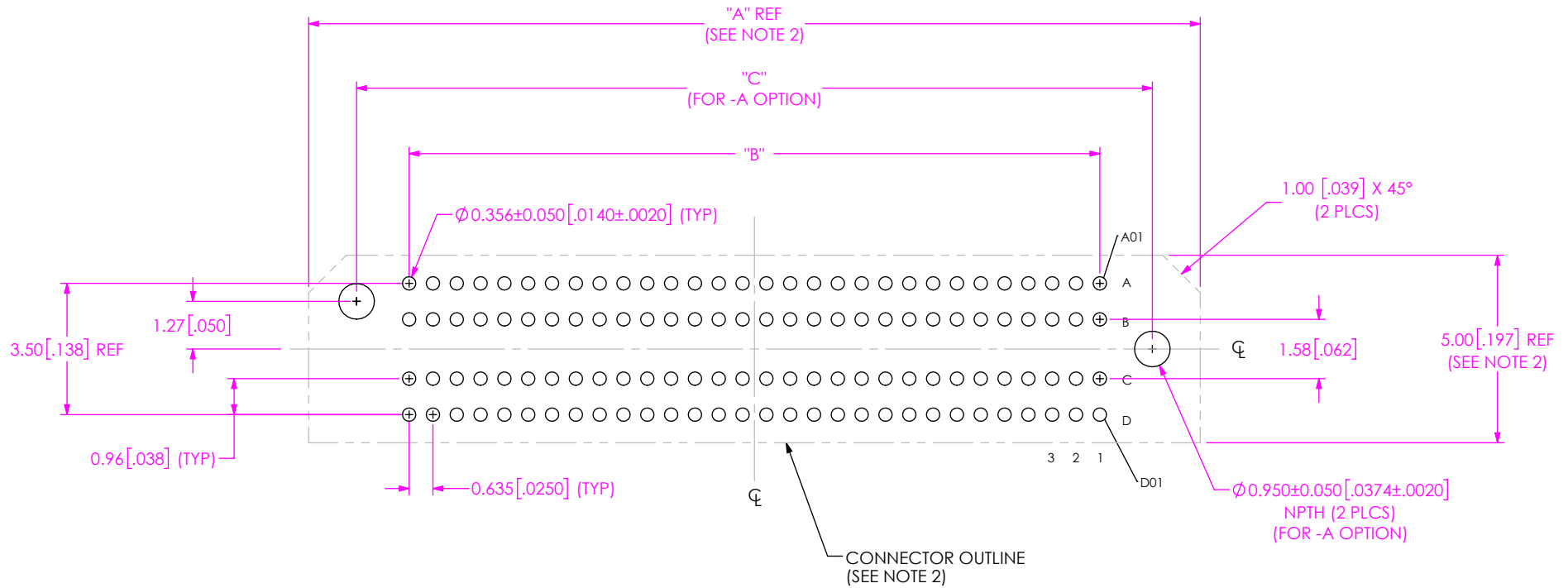

FIG 1
ADM6-30-XX.X-XXX-4-X-A FOOTPRINT SHOWN

| TABLE 1 | | | |
|-------------------|---------------|-----------------|---------------|
| No OF POS PER ROW | "A" | "B" | "C" |
| -10 | 11.07 [0.436] | 5.715 [0.2250] | 8.52 [0.335] |
| -20 | 17.42 [0.686] | 12.065 [0.4750] | 14.87 [0.585] |
| -30 | 23.77 [0.936] | 18.415 [0.7250] | 21.22 [0.835] |
| -40 | 30.12 [1.186] | 24.765 [0.9750] | 27.57 [1.085] |
| -50 | 36.47 [1.436] | 31.115 [1.2250] | 33.92 [1.335] |
| -60 | 42.82 [1.686] | 37.465 [1.4750] | 40.27 [1.585] |
| **_70 | 49.17 [1.936] | 43.815 [1.7250] | 46.62 [1.835] |
| **_80 | 55.52 [2.186] | 50.165 [1.9750] | 52.97 [2.085] |
| **_90 | 61.87 [2.436] | 56.515 [2.2250] | 59.32 [2.335] |
| **_100 | 68.22 [2.686] | 62.865 [2.4750] | 65.67 [2.585] |

** = NOT ENGINEERING APPROVED

NOTES:

1. ALL DIMENSIONS ARE SYMMETRIC ABOUT THE CENTERLINE.
2. CONNECTOR ENVELOPE DIMENSIONS, OTHER COMPONENTS PLACED ON PCB SHALL AVOID THIS ZONE.

PROPRIETARY NOTE
THIS DOCUMENT CONTAINS CONFIDENTIAL AND PROPRIETARY INFORMATION AND ALL DESIGN, MANUFACTURING, REPRODUCTION, USE, PATENT RIGHTS AND SALES RIGHTS ARE EXPRESSLY RESERVED BY SAMTEC, INC. THIS DOCUMENT SHALL NOT BE DISCLOSED, IN WHOLE OR PART, TO ANY UNAUTHORIZED PERSON OR ENTITY NOR REPRODUCED, TRANSFERRED OR INCORPORATED IN ANY OTHER PROJECT IN ANY MANNER WITHOUT THE EXPRESS WRITTEN CONSENT OF SAMTEC, INC.



520 PARK EAST BLVD, NEW ALBANY, IN 47150
PHONE: 812-944-6733 FAX: 812-948-5047
e-Mail info@SAMTEC.com code 55322

NOTE:
STENCIL TO BE .102[.0040] THICK.

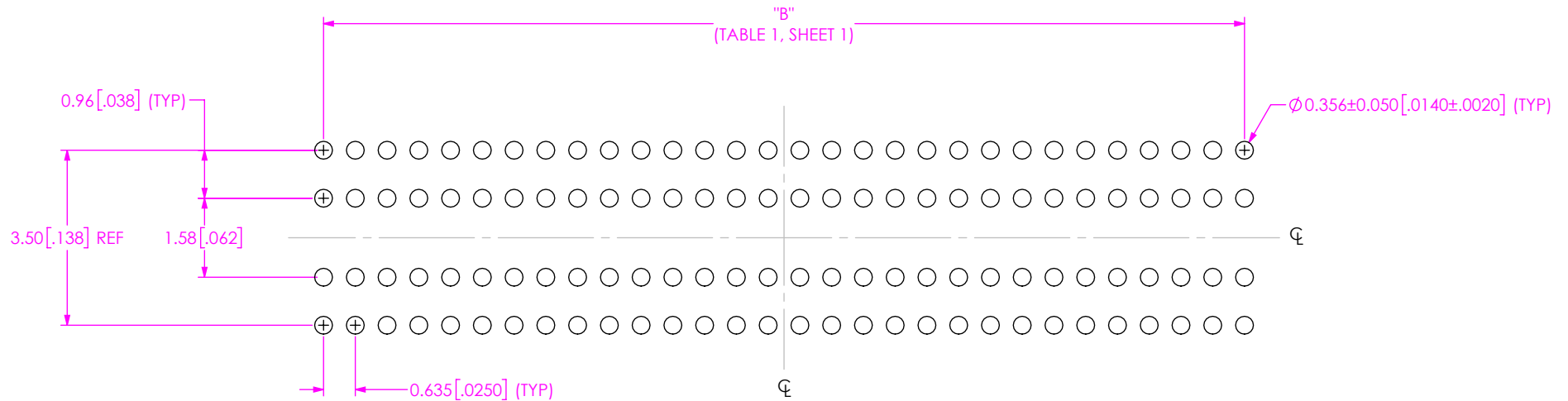

FIG 2
ADM6-30-XX.X-XXX-4-X-A STENCIL SHOWN

• PROPRIETARY NOTE •
THIS DOCUMENT CONTAINS CONFIDENTIAL AND PROPRIETARY INFORMATION AND ALL DESIGN, MANUFACTURING, REPRODUCTION, USE, PATENT RIGHTS AND SALES RIGHTS ARE EXPRESSLY RESERVED BY SAMTEC, INC. THIS DOCUMENT SHALL NOT BE DISCLOSED, IN WHOLE OR PART, TO ANY UNAUTHORIZED PERSON OR ENTITY NOR REPRODUCED, TRANSFERRED OR INCORPORATED IN ANY OTHER PROJECT IN ANY MANNER WITHOUT THE EXPRESS WRITTEN CONSENT OF SAMTEC, INC.

samtec
520 PARK EAST BLVD, NEW ALBANY, IN 47150
PHONE: 812-944-6733 FAX: 812-948-5047
e-Mail info@SAMTEC.com code 55322

DESIGNED & DIMENSIONED
IN MILLIMETERS[INCHES]

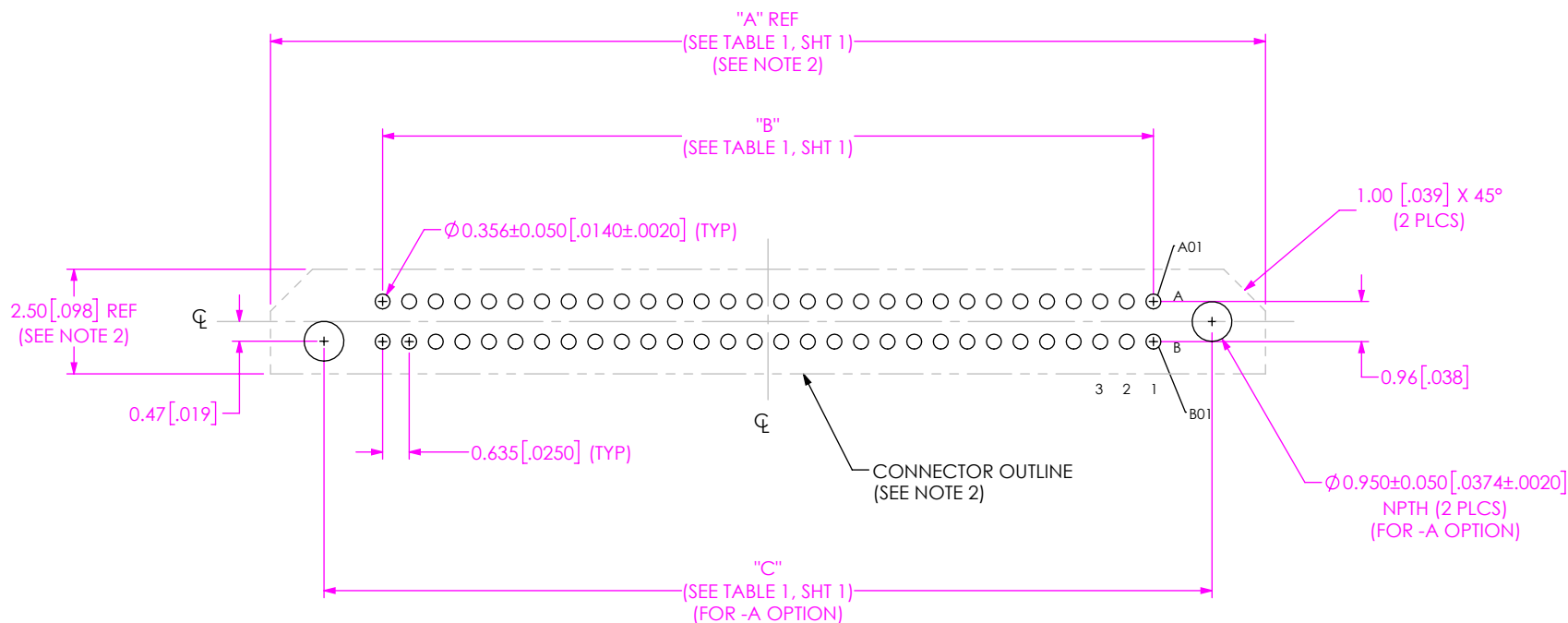

FIG 3
ADM6-30-XX.X-XXX-2-X-A FOOTPRINT SHOWN

• PROPRIETARY NOTE •
THIS DOCUMENT CONTAINS CONFIDENTIAL AND PROPRIETARY INFORMATION AND ALL DESIGN, MANUFACTURING, REPRODUCTION, USE, PATENT RIGHTS AND SALES RIGHTS ARE EXPRESSLY RESERVED BY SAMTEC, INC. THIS DOCUMENT SHALL NOT BE DISCLOSED, IN WHOLE OR PART, TO ANY UNAUTHORIZED PERSON OR ENTITY NOR REPRODUCED, TRANSFERRED OR INCORPORATED IN ANY OTHER PROJECT IN ANY MANNER WITHOUT THE EXPRESS WRITTEN CONSENT OF SAMTEC, INC.



520 PARK EAST BLVD, NEW ALBANY, IN 47150
PHONE: 812-944-6733 FAX: 812-948-5047
e-Mail info@SAMTEC.com code 55322