

## Magnetic rotary hollow-shaft position sensor

# Contactless sensor PST-360



The PST-360 through hole / hollow-shaft position sensors combine three critical design features; 1) through hole where the shaft passes through the sensor, 2) high accuracy absolute position feedback over up to 360 degrees, and 3) a true non-contacting sensing element. Piher's design does not rely on gears or other rotating parts.

This innovative and unique patented design features the following advantages:

- Compliments the attributes of the target application.
- Mechanical integrity that matches customer's application by design.
- Unique shaft mounted design that mounts at the pivot point of the application.
- No levers, connecting rods or mechanical interfaces needed.
- Adapts to shaft's eccentricity, mounting tolerances and mechanical wear over the life of the application.

## Mechanical specifications

Rotational life (depends on application and mounting)	up to 50.000.000 cycles.
Operating temperature <sup>1</sup>	-40°C to +125°C.

## Electrical specifications

Linearity <sup>1</sup>	±1% absolute (0.5% upon request).
Angular range	Programmable from 15 to 360 degrees.
Output <sup>2</sup>	Analog (Ratiometric), PWM. Serial protocol (SPI) and CAN SAE J1939 upon request.
Switch output	Upon request. Programmable.
Angular Resolution (depends on electrical angle and rotational speed)	Analog & PWM: up to 12 bits. Serial protocol (SPI): up to 14 bits.
Supply voltage <sup>1</sup>	Up to 25V.
Supply current	Typ 8.5mA for single version. Typ 17mA for redundant version.

<sup>1</sup> Others: check availability. Ferromagnetic materials close to the sensor (i.e. shaft, mounting surface) may affect the sensor's linearity. Please contact Piher for advise.

<sup>2</sup> CAN protocol model: physical dimensions may vary. Check available versions before ordering.

## Features

- Simple and robust magnetic design.
- High resolution (up to 14-bit).
- Ratiometric analog or PWM.
- Absolute position feedback up to 360° (keeps position on power loss).
- True full redundant version.
- Sealed construction for harsh environments such as off-highway and marine.
- Protected from dust, moisture, vibration and extreme temperatures.
- Endless rotation.
- Fully programmable transfer function output at the factory with electrical outputs up to 360°.
- Self-diagnostic features.
- Over voltage protection and reverse voltage protection.
- Extended voltage input supply values.

Also upon request:

- Programmable switch output.
- CAN and SPI output.

## Industries served

- Automotive and On-highway (road vehicles, trucks, recreational vehicles, road sweepers).
- Off-highway (agriculture, construction and forestry, motorsport, airport operations).
- Material handling.
- Marine engines.
- Medical.
- Industrial.

## Applications

- Non-contacting long life angle / position sensor.
- Absolute rotary position sensor.
- Pedal position sensor.
- Throttle / EGR valve and gear position sensor.
- Height and suspension sensor.
- Motor-shaft position sensor.
- Pivot point angle sensing.
- Off road / highway steering.
- Agricultural machinery hydraulic lift arms, scoops, articulation/joints.
- Forklifts / material handling.
- Industrial pumps.
- Accelerator / Steering / Shifter position sensor for marine outboard engine.
- Precision robotics, industrial equipment, HVACR monitoring & control, etc.

# Magnetic rotary hollow-shaft position sensor

## Contactless sensor PST-360

How to order (example: PST360G2-1A-C0018-ERA190-05K)

### Simple output

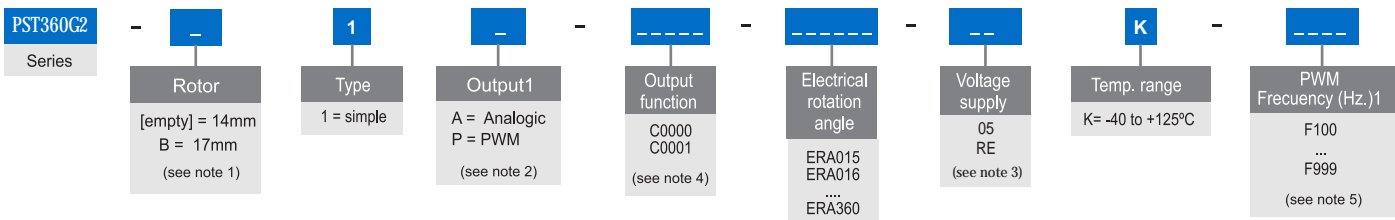

### Redundant output

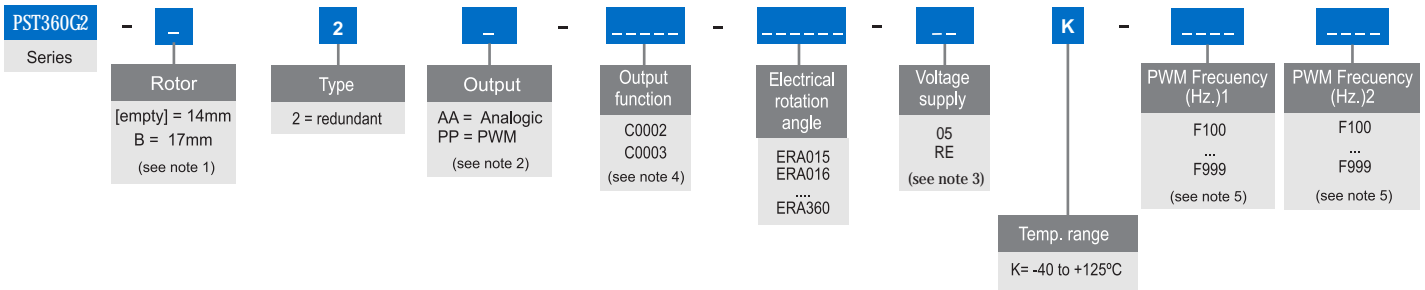

### Full redundant output

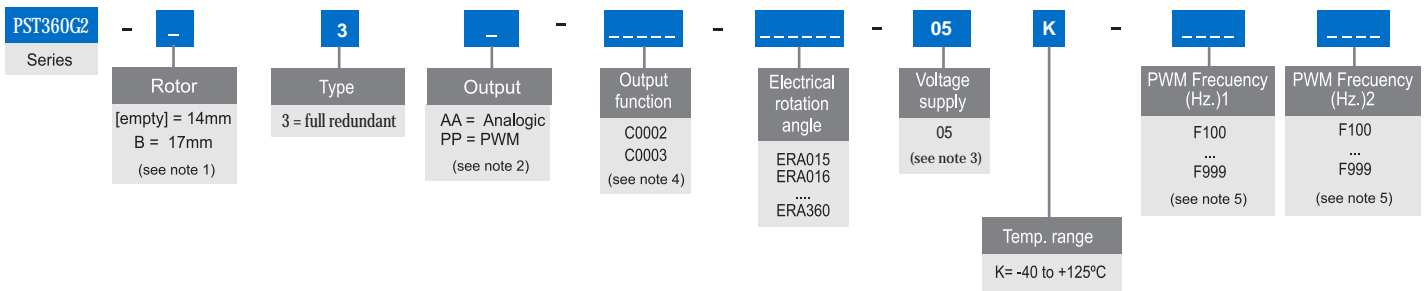

Other product configurations will be studied case by case.

#### Notes

- (1) Other rotors: check availability.
- (2) The analog output is a ratiometric output, proportional to:
  - For supply voltage 5V: to input supply voltage.
  - For supply voltage RE: to 5V.
- (3) 05: 5V ±10%  
RE: 7V - 25V
- (4) Other output functions available check availability. In the How To Order reference, enter CXXXX meanwhile the new output function reference is not defined.  
E.g.: PST360G2-1A-CXXXX-ERA190-05K
- (5) Leave empty if no applicable. Default frequency is 200 Hz.

# Magnetic rotary hollow-shaft position sensor

## Contactless sensor PST-360

### Dimensions

Hollow shaft diameter 14mm.



Download the STEP file here:  
<https://piher.net/piher/?p=838>

Recommended  
shaft dimensions

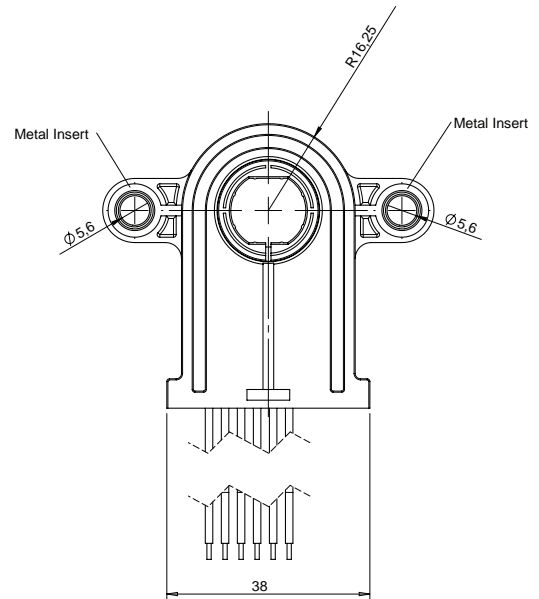
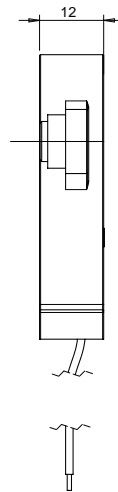
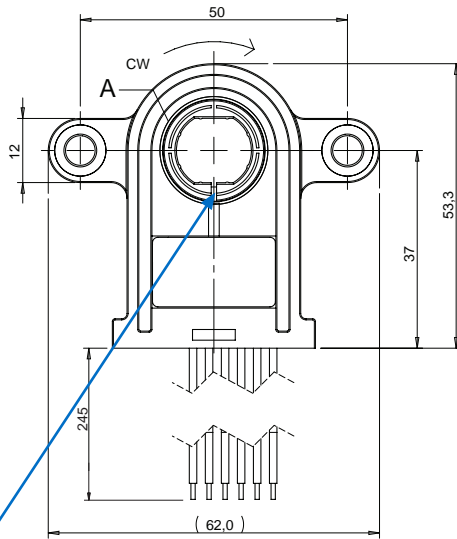
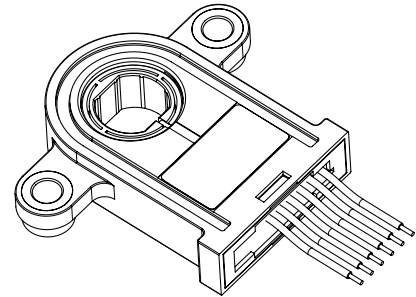
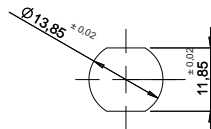
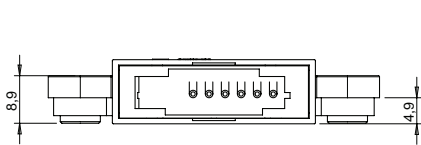

Rotor is shown at zero position.  
Sensor is delivered at random  
position.

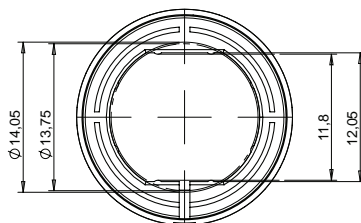

Rotor - Detail A

# Magnetic rotary hollow-shaft position sensor

## Contactless sensor

### PST-360

#### Dimensions

Hollow shaft diameter 17mm.

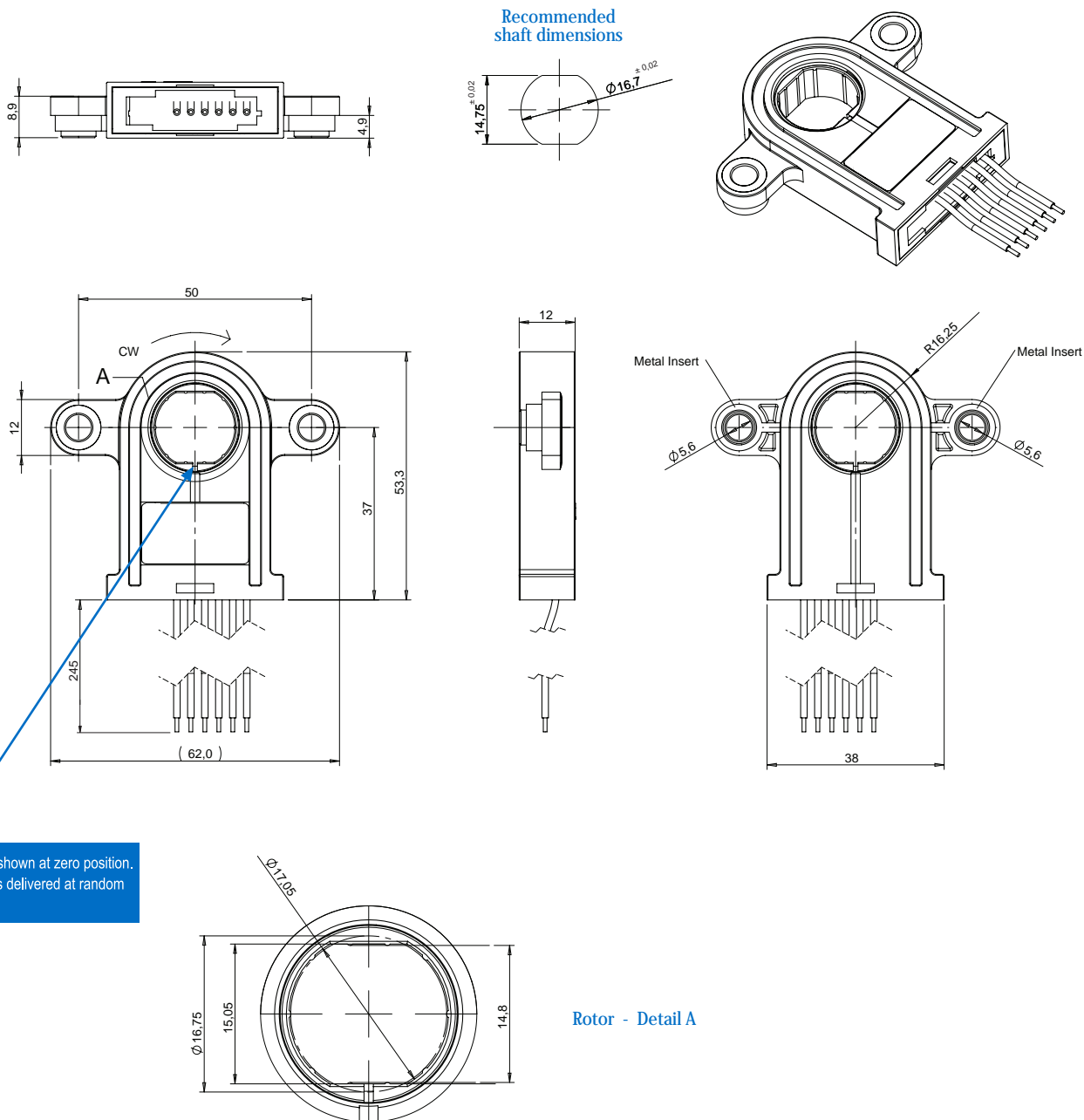

#### Mounting instructions

- 1.- Place the component on a flat surface.
- 2.- Fit the shaft of the application (see recommended shaft dimensions) through the sensor's rotor avoiding any mechanical play/wobble.
- 3.- Fasten the two M5 screws (M5 washers are recommended).

# Magnetic rotary hollow-shaft position sensor

## Contactless sensor

### PST-360

#### Connections scheme

Simple analog output connection wiring scheme.  
Other versions available upon request.

- Brown = Power supply.
- Blue = Ground.
- Black = Signal output.
- White = Not used.
- Grey = Not used.

Fly leads with Wire: 0.35mm<sup>2</sup>. TXL SAE J1128.  
Check availability for the connector options.

#### Ferromagnetic materials / Note

Off-the-shelf sensor is programmed and calibrated with non-ferromagnetic shaft and mount plate. Any other configuration can be provided upon request.

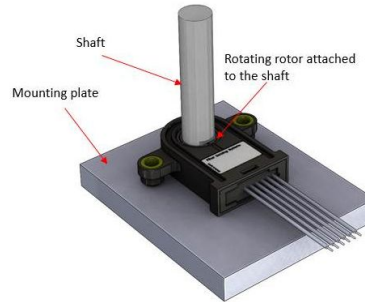

#### Output examples

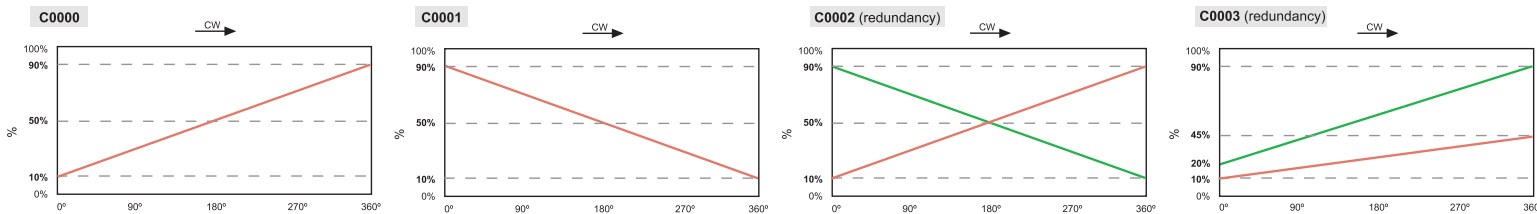

#### Disclaimer

Ferromagnetic parts close to the sensor, including the shaft, may modify the performance of the sensor. Therefore, this has to be communicated to Piher for prior analysis. No external magnetic perturbations are considered on the application where the sensor is mounted. If so, amplitude and direction of flux density generator type and characteristics (magnet, cable, motor...) must be notified to Piher.

The product information in this catalogue is for reference purposes. Please consult for the most up to date and accurate design information. Piher Sensors & Controls S.A., its affiliates, agents, and employees, and all persons acting on its or their behalf (collectively, "Piher"), disclaim any and all liability for any errors, inaccuracies or incompleteness contained herein or in any other disclosure relating to any product described herein.

Piher disclaims any and all liability arising out of the use or application of any product described herein or of any information provided herein to the maximum extent permitted by law. The product specifications do not expand or otherwise modify Piher's terms and conditions of sale, including but not limited to the warranty expressed therein, which apply to these products.

No licence, express or implied, by estoppel or otherwise, to any intellectual property rights is granted by this document or by any conduct of Piher.

The products shown herein are not designed for use in medical, life-saving, or life-sustaining applications unless otherwise expressly indicated. Customers using or selling Piher products not expressly indicated for use in such applications do so entirely at their own risk and agree to fully indemnify Piher for any damages arising or resulting from such use or sale. Please contact authorised Piher personnel to obtain written terms and conditions regarding products designed for such applications. Product names and markings noted herein may be trademarks of their respective owners.

Information contained in and/or attached to this catalogue may be subject to export control regulations of the European Community, USA, or other countries. Each recipient of this document is responsible to ensure that usage and/or transfer of any information contained in this document complies with all relevant export control regulations. If you are in any doubt about the export control restrictions that apply to this information, please contact the sender immediately. For any Piher Exports, Note: All products / technologies are EAR99 Classified commodities. Exports from the United States are in accordance with the Export Administration Regulations. Diversion contrary to US law is prohibited.

Piher is an Amphenol™ company.



**RoHS  
compliant  
REACH**



All Piher products can be adapted to meet customer's requirements.  
Due to continuous process improvement, specifications are subject to change without notice.  
Please always use the datasheets published at our website [www.piher.net](http://www.piher.net) for the most up-to-date information.

v060520

#### Piher Sensing Systems

Potentiometers | [Hall-effect sensors](#) | Inductive sensors  
Printing electronics | Value added assemblies

#### Contact

Piher Sensors & Controls SA  
Poligono Industrial Municipal  
Vial T2 N°22  
31500 Tudela - Spain  
Tel: +34-948-820450

[sales@piher.net](mailto:sales@piher.net)

[www.piher.net](http://www.piher.net)

**PIHER** *sensing systems*