

ZSSC3240

Sensor Signal Conditioner IC for Resistive Sensors

Description

The ZSSC3240 is a sensor signal conditioning IC (SSC) for highly accurate amplification, digitization, and sensor-specific correction of resistive sensor signals. The ZSSC3240 is suitable for bridge and half-bridge sensors, as well as external voltage-source element and single-element sensors (e.g., Pt100 and external temperature sensor diodes) powered by an on-chip current source. Digital compensation of the sensor offset, sensitivity, temperature drift, and non-linearity is accomplished via a 26-bit math core running a correction algorithm with calibration coefficients stored in a non-volatile, reprogrammable memory. The programmable, integrated sensor front-end allows optimally applying various sensors for a broad range of applications.

The ZSSC3240 provides measurement value readouts and programming capabilities via an I2C, SPI, or one-wire interface (OWI). Three different operation modes allow optimal development of digital, digital-analog, and analog-output smart sensor modules including wake-up on request, continuous-on/fast-response, and automatic/cyclic sensor measurement operations. Absolute and ratiometric voltage, current-loop, or interrupt analog outputs are supported by the ZSSC3240. The analog output options and digital interface options (for calibration and/or a digital application interface) can be combined.

Basic Application Diagram

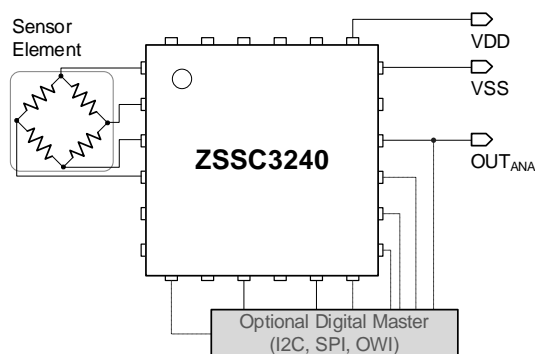

Features

- Digital communication and calibration interfaces
 - SPI up to 10MHz
 - I2C (Standard, Fast, and High-Speed Mode)
 - One-wire-interface (OWI), up to 100kBit/s
- Accommodates nearly all resistive bridge sensor types (signal spans from 1mV/V up to 500mV/V)
- Supports different sensor element configurations:
 - Resistive bridge or half-bridge
 - Resistive divider string
 - Voltage source
- On-chip temperature sensor
- External temperature sensing supported, e.g. sensor-bridge as temperature detector, external diode, etc.
- Support for Pt100
- Programmable 16-bit digital-to-analog-converter and output:
 - (0V to 1V) or (0V to 5V) absolute voltage output
 - V_{DD}-ratiometric voltage output
 - 4mA to 20mA current-loop output supported
 - 0V to 10V absolute-voltage output supported
- On-chip voltage regulators for sensor supply, and IC operation
- Support for extra regulation by external transistor, for example JFET
- Programmable 24-bit sensor-signal-conditioning math core
- Reprogrammable, nonvolatile memory (NVM)
- Programmable measurement scheduler for continuous sensing applications, with optimized balance of
 - Energy consumption
 - Output update rate
 - Sensor-signal-conditioning accuracy
 - Self-diagnostic coverage and system safety
- On-chip diagnostics:
 - Sensor connection
 - Broken-chip-check / chipping-check
 - Memory integrity

Physical Characteristics

- Supply voltage, V_{DD} : 2.7V to 5.5V; with external transistor, for example JFET: 5V to 48V
- Operating temperature: -40°C to 125°C
- Supported sensor elements: 0.5kΩ to 60kΩ
- Available as die on wafers or 4 × 4 mm² 24-QFN with wettable flanks, allowing visual inspection of QFN reflow quality

Typical Applications

- Calibrated, continuously operating sensors with digital interface and/or analog output: (absolute or ratiometric) voltage or current loop output
- Enables smart, digital sensors for energy-efficient solutions
- Pressure, flow, and level sensing
- Industrial applications; e.g. process/factory automation
- Consumer / white goods, e.g. HVAC, weight scales
- Medical applications, e.g. blood pressure, continuous smart health monitors

Block Diagram

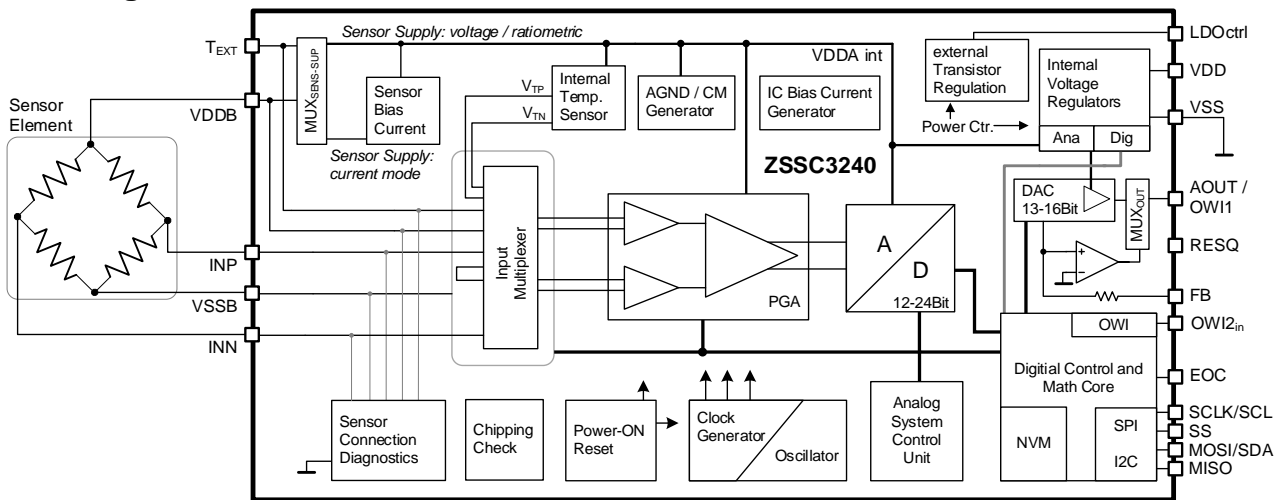

Typical Application Examples

Digital Half-Bridge Sensor, e.g. PT100

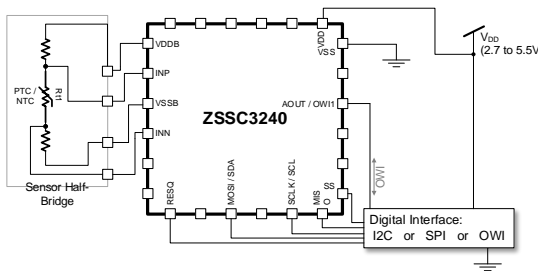

Analog Sensor with Absolute Voltage Out

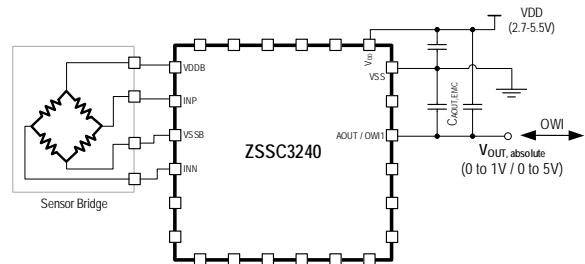

Sensor with Ratiometric Voltage Output and Digital Interface

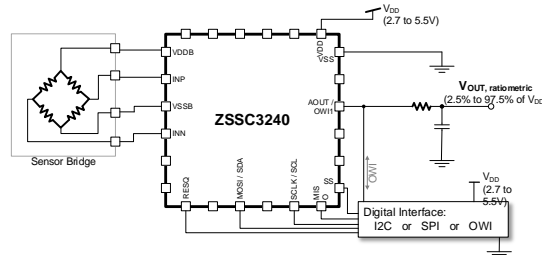

Analog Sensor with Current Loop Output, OWI, and External JFET

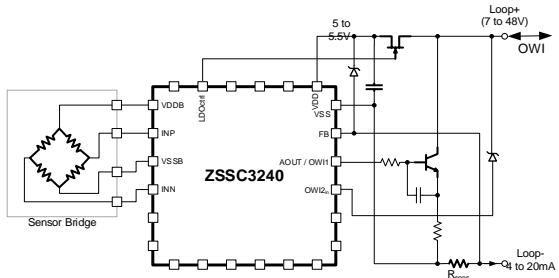

ZSSC3240

Sensor Signal Conditioner IC for Resistive Sensors

Contents

1. Pin Assignments	6
2. Pin Descriptions	7
3. Absolute Maximum Ratings	8
4. Recommended Operating Conditions	8
5. Electrical Characteristics	8
6. Device Description	11
6.1 Signal Flow	12
6.2 Analog (Sensor) Front-End.....	12
6.2.1. Programmable-Gain Amplifier (PGA).....	13
6.2.2. Analog-to-Digital Converter (ADC).....	15
6.2.3. Internal Temperature Sensor	17
6.2.4. Supported Supplies for Sensor Elements and Additional, External Temperature Sensing..	17
6.3 On-Chip Diagnostics.....	22
6.4 Digital Interfaces	24
6.4.1. SPI.....	24
6.4.2. I2C.....	27
6.4.3. One-Wire-Interface, OWI	28
6.5 Measurement and Output Options	32
6.5.1. Single Measurements, Digital Raw Results, and SSC Results	32
6.5.2. Cyclic, Continuous, Repeated Measurements – Measurement Scheduler	34
6.5.3. Analog Outputs: Digital-to-Analog Converter (DAC).....	34
6.5.4. Output Interrupt Signaling	37
6.6 System Setup and Control.....	39
6.6.1. Digital Commands.....	40
6.6.2. Nonvolatile Memory (NVM)	43
6.6.3. Digital Sensor-Signal-Conditioning Mathematics.....	55
6.7 External, Extra LDO (LDOctrl) for Applications for > 5.5V	58
7. Calibration	59
8. Package Outline Drawings	59
9. Marking Diagram	59
10. Ordering Information	60
11. Glossary	60
12. Revision History	61

Figures

Figure 1.	Pin Assignments for 4 × 4 mm ² 24-QFN Package – Top View.....	6
Figure 2.	Pin (Pad) Assignments for Bare Die	6
Figure 3.	Main Operating Modes of the ZSSC3240.....	11
Figure 4.	Analog Sensor Front-End Topology.....	13
Figure 5.	SPI Configuration CPHA=0.....	25
Figure 6.	SPI Configuration CPHA=1	25
Figure 7.	SPI Command Request	26
Figure 8.	SPI Read Data	26
Figure 9.	SPI Read Status.....	26
Figure 10.	I2C Command Request	27
Figure 11.	I2C Read Data	27
Figure 12.	I2C Read Status.....	27
Figure 13.	General Block Schematic of the OWI Interface	28
Figure 14.	OWI Timing Diagram.....	29
Figure 15.	OWI Extra (Activation) Pulse for Concurrent OWI and Analog Output Configuration	29
Figure 16.	OWI Command Request.....	30
Figure 17.	OWI Response by ZSSC3240	31
Figure 18.	Example Configuration for the Measurement Scheduling and Cyclic Mode Operation.....	34
Figure 19.	DAC and Analog Output Topology.....	35
Figure 20.	Current Loop Configuration.....	37
Figure 21.	EOC and Interrupt Thresholds	39
Figure 22.	Digital IC Section Architecture	40
Figure 23.	LDOctrl Application Topology	58

Tables

Table 1.	Pin Descriptions	7
Table 2.	Absolute Maximum Ratings	8
Table 3.	Recommended Operating Conditions.....	8
Table 4.	Electrical Characteristics.....	8
Table 5.	PGA Gain: Stage 1.....	13
Table 6.	PGA Gain: Stage 2.....	14
Table 7.	Absolute Offset Shift – Properties.....	14
Table 8.	Absolute Offset Shift – Differential Sensor Signal’s Offset Compensation.....	14
Table 9.	PGA Input Span Ranges.....	15
Table 10.	Single Analog-to-Digital Conversion	16
Table 11.	ADC Offset Shift.....	16
Table 12.	Sensor Supply Options	17
Table 13.	Sensor Supply – Main Sensing.....	18
Table 14.	Sensor Bias Currents – Sensor Sourcing in Current Mode	19
Table 15.	Sensor Supply – Temperature Sensing.....	19
Table 16.	Diagnostic Signalization Options with ZSSC3240	22
Table 17.	Information Assignment for <i>CHECK_DIAG</i> Command: Output Register <i>diagnosticreg</i> [15:0].....	23
Table 18.	General Status Byte	24
Table 19.	Mode Status	24
Table 20.	SPI Interface Parameter	26
Table 21.	I2C Interface Parameter.....	27
Table 22.	OWI Dimensioning Examples	29
Table 23.	OWI Interface Parameters	29
Table 24.	Data Format of Raw ADC Readings	32
Table 25.	Data Format of Corrected, SSC Results (<i>S</i> and <i>T</i>).....	32
Table 26.	Typical Conversion Times for Complete SSC Sensor Measurements: SM, TM	33
Table 27.	Typical Conversion Times and Noise Performance for Complete SSC Measurements	33
Table 28.	DAC Configurations	35
Table 29.	Direct Voltage Outputs.....	35
Table 30.	Recommended Operating Conditions for Voltage Output	36
Table 31.	ZSSC3240 Current-Loop-Specific Properties	36
Table 32.	Data Format of Interrupt Thresholds (TRSH1 and TRSH2).....	38
Table 33.	Command List.....	40
Table 34.	Memory (NVM) Content Assignments	44
Table 35.	Data Format of 24-bit SSC Coefficients.....	55
Table 36.	Data Format of Corrected, SSC Results (<i>S</i> and <i>T</i>).....	55
Table 37.	IC Supply, V_{DD} Target Level Selection with External Voltage Regulation, External LDO.....	58
Table 38.	External LDO Operating Conditions.....	58

1. Pin Assignments

The ZSSC324x is available as 8-inch wafers and in a 24-QFN package. Detailed information about die and wafers is available on request (see last page for contact information).

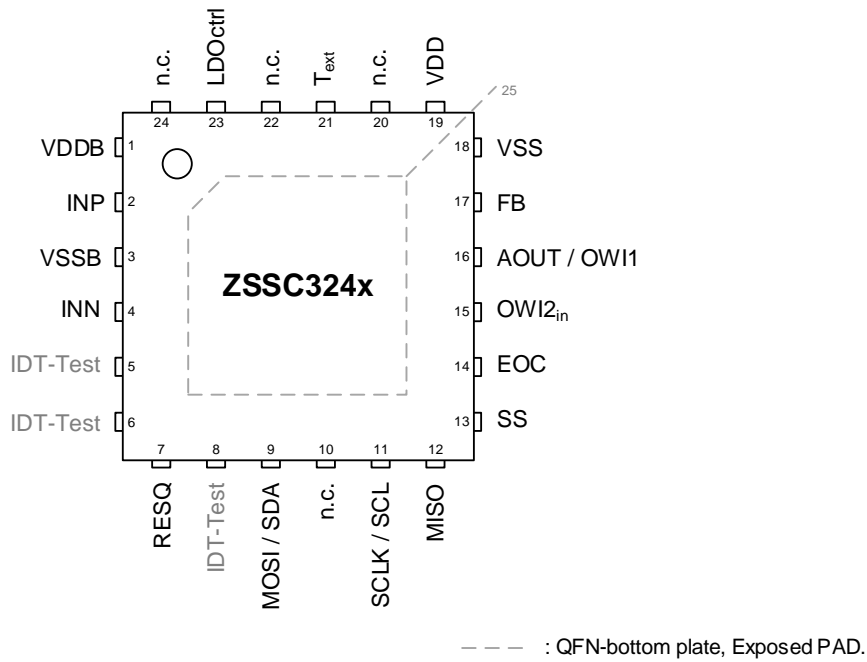

Figure 1. Pin Assignments for 4 × 4 mm² 24-QFN Package – Top View

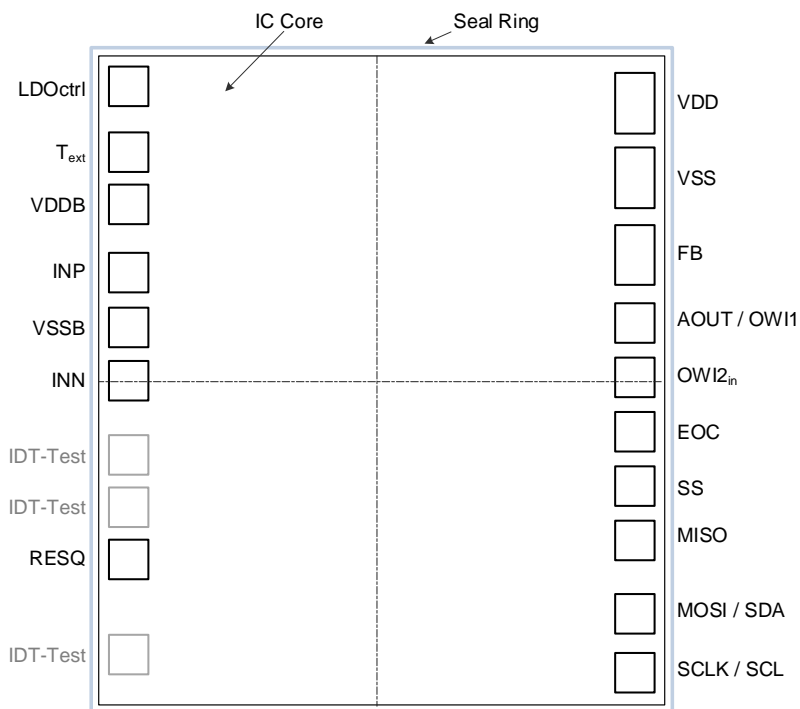

Figure 2. Pin (Pad) Assignments for Bare Die

2. Pin Descriptions

Table 1. Pin Descriptions

Pin Number	Name	Type	Description
1	VDDB	Analog Input/Output	Positive sensor (bridge) supply or sensor-signal input.
2	INP	Analog Input	Positive sensor (bridge) signal.
3	VSSB	Analog Input	Sensor (bridge) ground or sensor-signal input.
4	INN	Analog Input	Negative sensor (bridge) signal.
5	IDT-test	–	Renesas-internal use only. Connect to VSS or no connection; leave pin floating.
6	IDT-test	–	Renesas-internal use only. Connect to VSS or no connection; leave pin floating.
7	RESQ	Digital Input	Digital IC reset (low active); internal pull-up.
8	IDT-test	–	Renesas-internal use only. Connect to VSS or no connection; leave pin floating.
9	MOSI/SDA	Digital Input/Output	Digital data input for SPI or bidirectional data I/O for I2C. Pull-up to VDD.
10	n.c.	–	No connection. Leave pin floating.
11	SCLK/SCL	Digital Input	Clock input for SPI or I2C interface. Referenced to applied VDD level.
12	MISO	Digital Output	Data output from ZSSC3240 to master for SPI interface. Referenced to applied VDD level.
13	SS	Digital Input	Slave select (interface enable) for SPI. Referenced to applied VDD level.
14	EOC	Digital Output	End-of-conversion and output interrupt signal.
15	OWI2 _{in}	Digital Input	Optional OWI interface input line for current-loop applications.
16	AOUT/OWI1	Analog Output; Digital Input/Output	Analog smart-sensor output signal and/or OWI-interface input/output line.
17	FB	Analog Output	Current-loop application feedback output (level below VSS!). No connection if not used.
18	VSS	Ground	Power supply ground.
19	V _{DD}	Supply	Power supply.
20	n.c.	–	No connection. Leave pin floating.
21	T _{EXT}	Analog Output	Current drive output for external temperature sensor and/or bridge in Current Mode. A 1500Ω serial resistor is built in the IC internally for pad-protection purposes.
22	n.c.	–	No connection. Leave pin floating.
23	LDOctrl	Analog Output	Control output (reference signal) for (optional) external regulator / supply control loop.
24	n.c.	–	No connection. Leave pin floating.
25	Exposed PAD	-	QFN-bottom plate, i.e. Die-bottom/substrate. Leave pin floating (no electrical connection), PAD to be used for heat dissipation only.

3. Absolute Maximum Ratings

The absolute maximum ratings are stress ratings only. Stresses greater than those listed below can cause permanent damage to the device. Functional operation of the ZSSC3240 at absolute maximum ratings is not implied. Exposure to absolute maximum rating conditions might affect device reliability.

Table 2. Absolute Maximum Ratings

Symbol	Parameter	Conditions	Minimum	Maximum	Units
T_J	Junction temperature			135	°C
T_S	Storage temperature		-45	150	°C
	ESD – Human Body Model			4000	V
	ESD – Charged Device Model			750	V
	Latch-up		-100	+100	mA
V_{DD_max}	Maximum allowed for voltage supply	Referenced to VSS.	-0.3	6.5	V
V_{IF_max}	Voltage at digital interface pins	I2C pins: SDA, SCL	-0.3	5.5	V
V_{FB_max}	Voltage at FB pin	4mA to 20mA current loop interface	-2	2	V

4. Recommended Operating Conditions

Table 3. Recommended Operating Conditions

Symbol	Parameter	Minimum	Typical	Maximum	Units
V_{DD}	Power supply voltage	2.7	–	5.5	V
T_A	Ambient temperature (depending on the part code)	-40	–	125	°C
C_{VDD}	External (parasitic) capacitance between VDD and VSS, without external supply transistor regulation	0	10	–	nF
	External (parasitic) capacitance between VDD and VSS, with (optional) external supply transistor regulation	80	100	120	
$C_{VDD_B,EMC}$	Recommended, external capacitance between VDD_B and VSS for electro-magnetic immunity (EMI)	0	6.8	8	nF
$C_{AOUT,EMC}$	Recommended, external capacitance between AOUT versus VSS, and versus VDD for EMI [a]	0	22	33	nF
I_{Sensor}	Load current through external sensor element [b]	0.02	0.5	4	mA
$V_{DioDrop}$	External temperature diode and RTD input range, drop over external element referenced to T_{EXT} pin	-0.2	–	1	V
V_{Sens_in}	Absolute sensor signal input level, INN, INP pins	0.5	–	1.2	V
$V_{DDB_ratio_min}$	Minimum level at VDD_B [b]	0.9	–	–	V
$V_{SSB_ratio_max}$	Maximum level at VSS_B [b]	–	–	0.7	V
$I_{max_AOUT_V}$	Maximum current load at AOUT pin for voltage outputs	–	–	18	mA
SR_{VDD_POR}	Recommended V_{DD} rise slew rate for power-on-reset (POR) [c]	1.5	–	–	V/ms

[a] For applications with OWI-interface or analog voltage-output.

[b] With ratiometric sensor supply configuration; e.g. a ratiometric bridge or bridge as temperature sensor with internal or external R_t .

[c] Per design, there is no (theoretical) minimum V_{DD} slew rate to trigger a clean POR. Nevertheless, a reasonable slew rate is recommended.

5. Electrical Characteristics

All parameter values are valid only under specified operating conditions. All voltages are referenced to V_{SS} .

Table 4. Electrical Characteristics

Note: See important notes at the end of this table.

Symbol	Parameter	Conditions	Minimum	Typical	Maximum	Units
IC Supply						
I_{IC}	Current consumption, active IC	Excluding connected sensor elements (with LDOctrl enabled)	–	2.3	2.80	mA
I_{IDLE}	Idle current consumption, IC in Idle State	Typical value at 30°C, maximum value at 85°C (125°C) OWI and LDOctrl disabled	–	1.5	6 (22)	μA

Symbol	Parameter	Conditions	Minimum	Typical	Maximum	Units
I_{AVE}	Average current draw	Mean current consumption for one complete SSC measurement cycle per second at 16-bit digital-only output	–	–	3.5	μA
$V_{DD,LDOctrl}$	Target level regulation range to generate V_{DD} after external transistor, for example JFET	Using LDOctrl and external transistor; programmable setup: $V_{DD_ldoctrl_target}$ (see section 6.7)	4.6	5.2	5.5	V
Sensor Supply						
I_{SUP}	Sensor bias	In the case of a Current Mode sensor supply; setup in $temp_source$ and $sensor_sup$ (see section 6.2)	5	80	500	μA
Err_{TBIAS}	Relative sensor bias current error ^[a]		-3.5	-1	1.5	%
V_{TBIAS}	Drop over sensor bias current source	referenced $V_{DDA_{int}}$ from internal analog regulator	–	200	230	mV
V_{DDB} ($V_{DDA_{int}}$)	Internally regulated analog (bridge) sensor front-end supply	In the case of a ratiometric sensor supply, setup in $temp_source$ and $sensor_sup$	1.68	1.75	1.80	V
$PSRR_{LOW}$	Power supply rejection ratio ^[b] , only internal regulator	Attenuation of V_{DD} fluctuations in the range of $f_{VDD} = 0\text{Hz}$ to 10MHz	45	50	–	dB
$PSRR_{HIGH}$		$f_{VDD} > 10\text{MHz}$	20	–	–	dB
Analog-to-Digital Converter (ADC, A2D)						
r_{ADC}	Resolution		12	16	24	Bit
$f_{S,raw}$	Single-conversion rate, conversions per second	Single external sensor A2D conversion (without auto-zero measurement AZ); resolution dependent	0.21 (ADC: 24-bit)	3.39 (ADC: 16-bit)	13.00 (ADC: 12-bit)	kHz
V_{ADCmid} (AGND)	Differential ADC input common mode ^[c]	With internal regulator supplying V_{DDB} pin, typical: $V_{DDB}/2 = 875\text{mV}$ (equals PGA output common mode level)	–	0.5	–	V_{DDB}
$ENOB$ ^[g]	Effective number of bits, $3\sigma_{Noise}$ based	For gain < 78, shorted input, $r_{ADC} = 24\text{-bit}$, no oversampling	15.8	18.1	–	Bit
Digital-to-Analog Converter (DAC) and Analog Output						
r_{DAC}	Resolution		13	14	16	Bit
$t_{DACsettle}$	Analog voltage output settling time	Time from 30% steady state until 99% of new DAC output (100% out) value is reached; varies with level differences	0	65	150	μs
V_{DACout}	Addressable output voltage at AOUT pin	Absolute output, $Aout_setup = 010_{BIN}$ (see section 6.5.3.1)	0.025	–	1	V
		Absolute output, $V_{DD} > 5.01\text{V}$, $Aout_setup = 011_{BIN}$	0.025	–	5	V
		Ratiometric output, $Aout_setup = 001_{BIN}$	0.1	–	100	%VDD
BW_{DAC}	Output filter bandwidth	Without external components	12	15	20	kHz
SR_{out}	Output slew rate	Resistive load > 2k Ω , capacitive load < 20nF at Aout, temperature = 25°C	20	100	-	mV/ μs
I_{OUTmax}	Maximum output current	This current level must be overdriven from an OWI-Master, if concurrent DAC-output and OWI communication is configured.	10	12	18	mA
I_{DRloop}	Current loop driving current	$Aout_setup = 000_{BIN}$; depends on connected bipolar transistor for current loop application	–	100	160	μA
Programmable-Gain Amplifier (PGA)						
G_{amp}	Gain	120 steps	1.32	–	540	V/V
G_{err}	Gain error	Referenced to nominal gain, T = 25°C	-2.5	0	2.5	%
V_{CMin}	Supported input common mode	$V_{DDA_{int}} = 1.75\text{V}$, valid for ratiometric and current mode sensor supply	0.70	0.85	1.00	V
Sensor Signal Conditioning Performance						
f_{SSCout}	Output (Update) rate ^[d]	Cyclic operation	0.07	1.45	2.91	kHz
		SSC-corrected (S, T) digital output rate, ADC:16-bit (see section 6.6.3.1)	–	1.20	–	kHz
		Complete SSC cycle (S, T) including analog output update; ADC: 14-bit; DAC: 14-bit	1.35	1.45	1.60	kHz

Symbol	Parameter	Conditions	Minimum	Typical	Maximum	Units
$Err_{A,IC}$	ZSSC3240 accuracy error	Accuracy error with an ideally linear sensor (in temperature and measurand)	–	–	0.01	% FSO
V_{ioffsc}	Correctable (in PGA), absolute, differential input offset	Programmable in 1mV steps; accuracy: $\pm 5\%$ referenced to nominal setup	-15	0	15	mV
$\Delta_{ADC,c}$	Correctable (in ADC), relative, differential input offset	Percentage of sensor signal offset versus maximum sensor signal	0	–	98	%
Input						
V_{INP}, V_{INN}	Absolute sensor input	Voltages at INP and INN pin; resulting minimum/maximum differential voltages: $-700mV < V_{INDIFF} < 700mV$	0.5	–	1.20	V
V_{TEXT}	External temperature diode or RTD input range	At T_{EXT} pin	0.5	–	1.25	V
R_{SENSOR}	External sensor (bridge) resistance	$V_{DDB} = 1.75V$	0.5	–	60	k Ω
		For 4mA to 20mA current loop output	1.6	–	60	k Ω
$ V_{DIFFIN} $	Differential input signal range	Referenced to sensor supply ($V_{DDA,int}$); leading to full scale analog excitation	2.6	50	700	mV
Diagnostics						
R_{open}	Sensor connection loss; i.e., open threshold	INP vs. INN	70	–	–	k Ω
R_{short}	Sensor connection short threshold	INP vs. INN; T_{EXT} vs. V_{DDB}	–	–	100	Ω
$V_{s,valid}$	Valid sensor input signal	Beyond $V_{s,valid}$, sensor connection checks (such as in-range, etc.) signalize Diagnostic <i>FAULTs</i>	0.44	–	1.31	V
Power-Up						
t_{STA1}	Start-up Time	V_{DD} ramp up to interface communication	–	–	2	ms
t_{STA2}		V_{DD} ramp up to analog operation	–	–	2.5	ms
t_{WUP1}	Wake-up Time	Sleep to Active State interface communication	–	2	10	μs
t_{WUP2}		Sleep to Active State analog operation	–	–	2	ms
Oscillator						
f_{CLK}	Internal oscillator frequency		5.9	6.0	6.1	MHz
Temperature Sensor(s)						
r_{Temp}	Internal temperature sensor resolution	Setup: $ADT_{T_{sens,int}} = 13\text{-bit}$	12	35	–	Counts/K
R_t, R_t'	Internal low TC ^[f] top/bottom resistance for external temperature	Programmable with <i>internal_rt</i> and <i>extra_rt</i> ; applied if <i>temp_source</i> $\in \{010; 110\}$ (see section 6.2.4)	1.34	–	40	k Ω
Interface and Memory						
$f_{C,SPI}$	SPI clock frequency		0.05	1	12	MHz
$f_{C,I2C}$	I2C clock frequency		–	–	3.4	MHz
CD_{OWI}	OWI data rate		0.33	–	10	kBit/s
t_{PROG}	NVM program time	Programming time per 16-bit word	–	3	7	ms
n_{NVM}	NVM endurance	Number of reprogramming cycles	1000	10000	–	Numeric
$t_{RET,NVM}$	Data retention		10	–	–	Years

- [a] Referenced to nominal value. Relative errors are typically $< 1\%$ for sensor bias current setups $> 20\mu A$.
- [b] $PSRR = 20 \cdot \log_{10}(V_{DD}/V_{DDB})$: will be improved when applying external filter elements at V_{DD} and/or also using an external JFET regulator.
- [c] This parameter must be taken into account if automatic common mode regulation in the PGA is switched off (*pga_en_shift*; see section 6.2.1) and a non-symmetric sensor supply and input to the PGA ADC path have been configured.
- [d] There are several setups and parameters that allow optimizing and maximizing the output update rate; e.g., ADC and DAC resolutions, configurations for the measurement sequence, usage of the internal or an external temperature sensor.
- [e] V_{ioffsc} and $\Delta_{ADC,c}$ can be arbitrarily set up and combined. They work independently on each other.
- [f] Typical residual temperature variation of voltage across R_t, R_t' : 10ppm/K; maximum deviation: 150ppm/K at 40k Ω and $> 100^\circ C$, all other setups and conditions $< 60ppm/K$.
- [g] $ENOB = \log_2(2^{rADC} / 3\sigma_{Noise})$ with, for example $rADC[Bit] = 24$.

6. Device Description

The ZSSC3240 can be set up to for one of three main operating modes:

- Sleep Mode** The Sleep Mode is recommended for smart sensors with purely digital output. The ZSSC3240 automatically enters the idle state after command execution for minimum current consumption, whereas the interface is still listening and accepts commands. After receiving a valid command, the ZSSC3240 wakes up, executes the command, provides the results at the digital interface, where the results must be read, and returns to idle state after the data fetch. The results are only available once; repeated data fetch is not supported. In Sleep Mode, sensor measurement results cannot be provided at the analog output of ZSSC3240.
- Command Mode** The Command Mode is most appropriate for evaluation, test, and calibration purposes. In this mode, all commands are available, both digital and analog outputs are supported and all functionality is available. Command Mode can be used for applications requiring re-occurring (or even continuous) digital interaction, potential analog output, and minimum latency. Applications in Command Mode are only active on command request.
- Cyclic Mode** In Cyclic Mode, autonomous, cyclically repeated sensor measurements are performed and related digital and/or analog output updates are provided. Cyclic Mode is recommended for analog output applications. The cyclic sequence for measurements, diagnostics, and hence the output update rate is configurable.

The ZSSC3240 always enters the programmed *default_mode* after power-on (reset). One of the three operating modes can be set up as the default. After the ZSSC3240 is powered and has entered its default mode, changing to one of the other operating modes is possible via the mode change and start commands: *START_CM*, *START_CYC*, *START_SLEEP* (see section 6.6.1 for details).

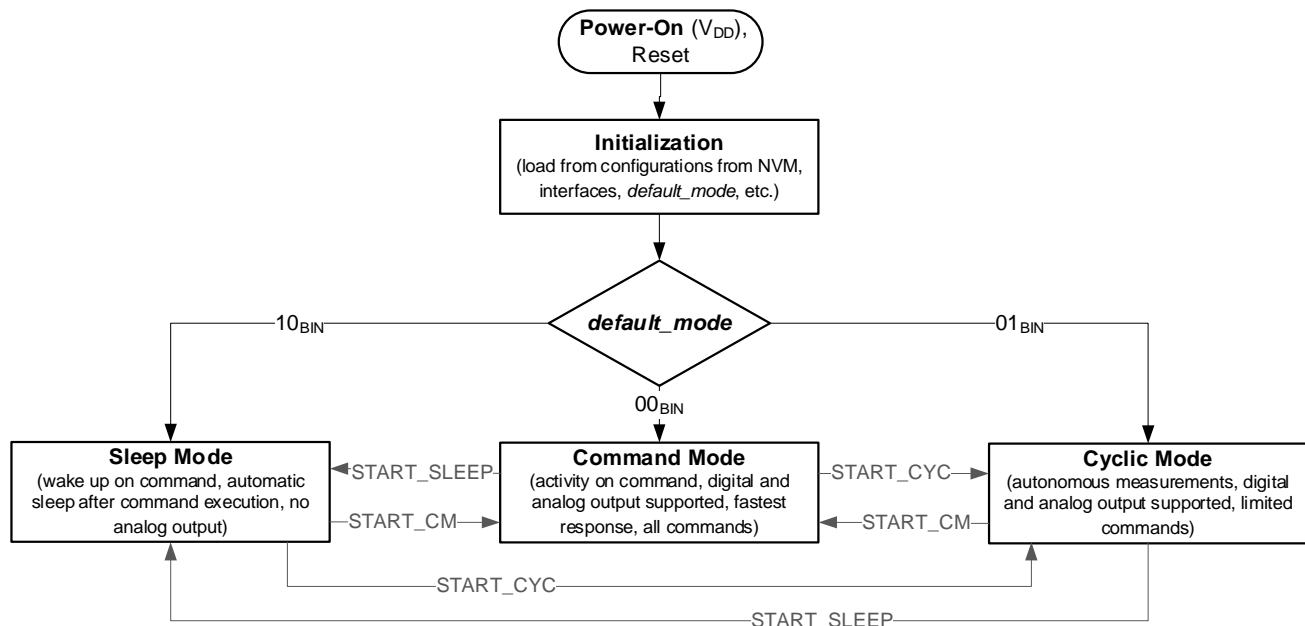

Figure 3. Main Operating Modes of the ZSSC3240

The ZSSC3240 supports three different types of digital interfaces: I2C, SPI, and OWI. All interface types allow application and control of each of the main operating modes.

Exception: The combination of Sleep Mode as the default mode (see the *default_mode* bit in the *SSF1* register in Table 34) and the OWI interface is not supported. The OWI interface must be disabled (*owi_off* = 1, bit[13] in the *SSF1* register) for correct Sleep Mode operation.

When using commands to change the operating mode, e.g. *START_CM* or *START_SLEEP*, validation of the new operating mode is recommended; e.g., by reading an NVM register or simply retrieving the status byte.

Note: The ZSSC3240 always requires two or more interface command interactions after an operating mode change prior to any additional changes in the mode.

6.1 Signal Flow

See the figures on page 2 for the ZSSC3240 block diagram and circuit diagrams for different input sensors. The ZSSC3240 supports two sensor supplies: ratiometric voltage and current mode, i.e., sensor current bias. In the ratiometric sensor-supply configuration, *VDDB* and the power supply for analog circuitry are provided by an on-chip voltage regulator, which is optimized for power supply disturbance rejection (PSRR). To improve noise suppression, the digital blocks are powered by a separate voltage regulator. A power supervision circuit monitors all supply voltages and generates appropriate reset signals for initializing the digital blocks.

The System Control Unit controls the analog circuitry to perform the measurement types: external sensor, external or internal temperature, and offset measurement. The multiplexer selects the signal input to the amplifier, which can be the external signals from the input pins *INP*, *INN*, *T_{EXT}*, *VDDB*, and *VSSB* or the internal temperature reference sensor signals. A full measurement request will trigger an automatic sequence of all measurement types and all input signals. The basic sensor signal source configuration is set up in the *SSF1* register (see Table 34) in the on-chip memory.

The programmable gain amplifier (PGA) consists of two stages with programmable gain values. The ZSSC3240 employs a programmable analog-to-digital converter (ADC) optimized for conversion speed and noise suppression. The programmable resolution from 12 to 24 bits provides flexibility for adapting the conversion characteristics. To improve power supply noise suppression, the ADC uses the external sensor supply voltage, e.g., *VDDB* for the ratiometric supply of a connected full-bridge sensor element, as its reference voltage leading to a ratiometric measurement topology. The remaining IC-internal offset and the sensor element offset, i.e., the overall system offset for the amplifier and ADC, can be canceled via an offset and auto-zero measurement, respectively.

The math core accomplishes the auto-zero, span, and 1st and 2nd order temperature compensation of the measured external sensor signal. The correction coefficients are stored in the non-volatile memory.

The ZSSC3240 supports SPI, OWI, and I2C interface communication for controlling the ZSSC3240, configuration, and measurement result output. Analog output signals can be provided, which are proportional to the sensor signal that has been compensated for nonlinearity and temperature. The ZSSC3240 can also check and signalize numerous sensor and self-check diagnostic values.

6.2 Analog (Sensor) Front-End

The main blocks and functions of the analog sensor front-end of the ZSSC3240 are illustrated in Figure 4. As a typical first setup, the type and supply of the connected (external) sensor element should be determined and configured. The *sensor_sup* and *temp_source* bits in the *SSF1* register (03_{HEX}; see Table 34) of the NVM must be set up according to the connected sensor configuration.

Important: If using the current mode sensor biasing via the “Sensor Bias Current” block, which is configured with the *Tbiasout* bit field (see section 6.2.4), ensure that the selection for bias current combined with the dimensioning for the connected external sensor is within the input common mode constraints, *V_{CMmin}* (typical 0.85V) as defined in Table 4.

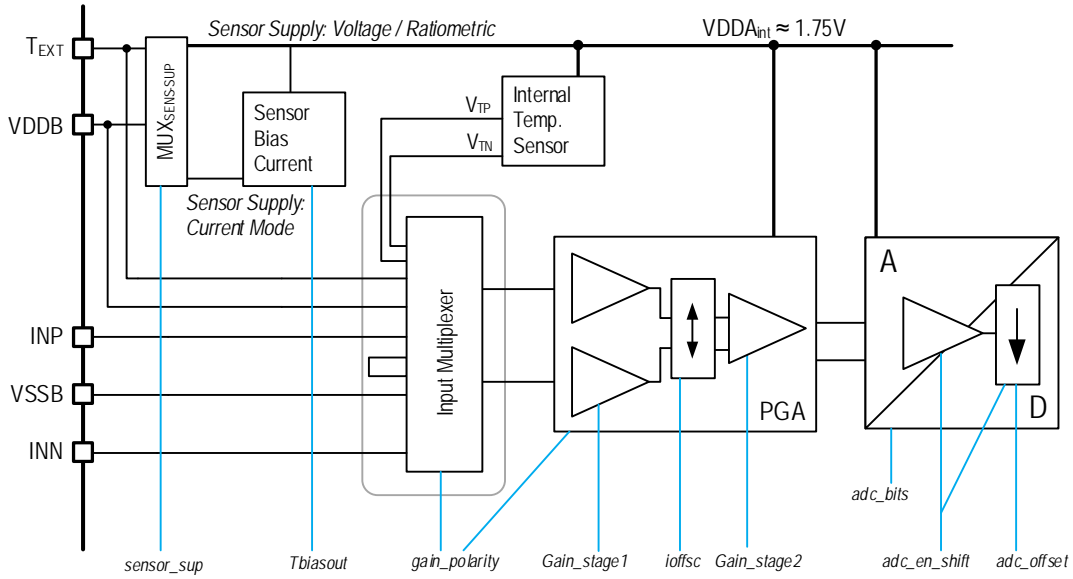

Figure 4. Analog Sensor Front-End Topology

6.2.1. Programmable-Gain Amplifier (PGA)

The amplifier has a fully differential architecture and consists of two stages. The amplification of each stage and the external sensor gain polarity are programmable via settings in the measurement configuration register:

- For the main sensor element: *SM_config1* and *SM_config2* (NVM addresses 14_{HEX} and 15_{HEX}; see Table 34)
- For an optional external temperature sensor: *extTemp_config1* and *extTemp_config2* (NVM addresses 16_{HEX} and 17_{HEX}; see Table 34).

The first 7 bits of the *_config1 registers are the programmable gain settings *Gain_stage1* and *Gain_stage2*. The options for the programmable gain settings are listed in Table 5 and Table 6. The resulting analog gain is the linear product of the stage 1 and stage 2 selection: $Gain_{PGA} = Gain_1 \cdot Gain_2$. With the programmable *Gain_polarity* bit in the *_config1 registers, the sign of the effective PGA gain can be swapped; e.g., to invert the sensor characteristic's slope and invert signal processing of the differential signal between INP and INN.

Table 5. PGA Gain: Stage 1

Gain_stage1[3:0]				Gain ₁ [V/V]
bit[3]	bit[2]	bit[1]	bit[0]	
0	0	0	0	1.2
0	0	0	1	2
0	0	1	0	4
0	0	1	1	6
0	1	0	0	12
0	1	0	1	20
0	1	1	0	30
0	1	1	1	40
1	0	0	0	60
1	0	0	1	80
1	0	1	0	120
1	0	1	1	150
1	1	0	0	200
1	1	0	1	240
1	1	1	0	300
1	1	1	1	Not assigned

Table 6. PGA Gain: Stage 2

Gain_stage2[2:0]			Gain ₂ [V/V]
bit[2]	bit[1]	bit[0]	
0	0	0	1.1
0	0	1	1.2
0	1	0	1.3
0	1	1	1.4
1	0	0	1.5
1	0	1	1.6
1	1	0	1.7
1	1	1	1.8

In addition to the amplification of the sensor input signals, the PGA's first stage can perform an absolute offset shifting of the differential sensor signal. This shift operation can be programmed in 1mV steps with the configuration setup *ioffsc* bit field in the *SM_config2* and *extTemp_config2* registers. The effective voltage-shift depends on the selected Gain₁, *Gain_stage1*. The V_{IOFFSC} values (in Table 8) correspond to the higher Gain₁ values, i.e. Gain₁ > 100. The PGA-operation including shift effect for a differential input signal, V_{DIFFin} can be described as:

$$V_{ADC,IN} = Gain_2 * Gain_1 * (V_{DIFFin} - V_{IOFFSC}) + Gain_2 * V_{IOFFSC} \tag{Equation 1}$$

Table 7. Absolute Offset Shift – Properties

Symbol	Parameter	Minimum	Typical	Maximum	Units
Δ _{IOFFSC}	Relative accuracy of the effectively applied Offset Shift referenced to the selected setup per <i>ioffsc</i> [4:0], IC-to-IC variation	0.89	0.98	1.07	-
TC _{neg,IOFFSC}	1 st order temperature coefficient for the change of the effective Offset Shift voltage for negative-voltage shift effects, i.e. <i>ioffsc</i> [4]=0	-0.25	-0.21	0	PPT/K
TC _{pos,IOFFSC}	1 st order temperature coefficient for the change of the effective Offset Shift voltage for positive-voltage shift effects, i.e. <i>ioffsc</i> [4]=1	0	0.21	0.25	PPT/K
SNR _{IOFFSC}	Fluctuation of output offset signal (V _{IOFFSC}) versus nominal value at 25°C; 20·log ₁₀ (V _{IOFFSC} /ΔV _{IOFFSC})	-	74	-	dB

The shifting can be configured independently for the main sensor and the optional, external temperature sensor. If the absolute offset shifting is enabled, then the ZSSC3240 current consumption increases by 100µA. The advantage of absolute offset shifting is an increase of analog dynamic range in the ZSSC3240's sensor front-end, which results in higher measurement result quality (less noise/fluctuations).

Table 8. Absolute Offset Shift – Differential Sensor Signal's Offset Compensation

<i>ioffsc</i> [4:0]					Shift Effect, V _{IOFFSC}
bit[4]	bit[3]	bit[2]	bit[1]	bit[0]	
0	0	0	0	0	0mV, no shift
0	0	0	0	1	-1mV
0	0	0	1	0	-2mV
0	0	0	1	1	-3mV
0	0	1	0	0	-4mV
0	0	1	0	1	-5mV
0	0	1	1	0	-6mV
0	0	1	1	1	-7mV
0	1	0	0	0	-8mV
0	1	0	0	1	-9mV
0	1	0	1	0	-10mV
0	1	0	1	1	-11mV
0	1	1	0	0	-12mV
0	1	1	0	1	-13mV
0	1	1	1	0	-14mV
0	1	1	1	1	-15mV

<i>ioffsc[4:0]</i>					Shift Effect, V_{IOFFSC}
bit[4]	bit[3]	bit[2]	bit[1]	bit[0]	
1	0	0	0	0	0mV, no shift
1	0	0	0	1	1mV
1	0	0	1	0	2mV
1	0	0	1	1	3mV
1	0	1	0	0	4mV
1	0	1	0	1	5mV
1	0	1	1	0	6mV
1	0	1	1	1	7mV
1	1	0	0	0	8mV
1	1	0	0	1	9mV
1	1	0	1	0	10mV
1	1	0	1	1	11mV
1	1	1	0	0	12mV
1	1	1	0	1	13mV
1	1	1	1	0	14mV
1	1	1	1	1	15mV

The PGA can perform an automatic adjustment for the PGA input to ADC input common mode. This can be enabled via the *pga_en_shift* bit in the **_config2* registers. The supportable input common mode range at the PGA, i.e. at the sensor front-end input, is constant per IC because it is derived from the internally regulated voltage $VDDA_{int}$.

Table 9. PGA Input Span Ranges

Total Gain, G_{AMP} Examples	Gain ₁	Gain ₂	Max. Input Span, Differential Signal Range [mV]
540	300	1.8	5.0
420	300	1.4	6.4
330	300	1.1	8.1
280	200	1.4	9.6
220	200	1.1	12.2
144	120	1.2	18.5
103	80	1.3	25.9
88	80	1.1	30.5
72	60	1.2	37.5
60	40	1.5	45
48	40	1.2	56
39	30	1.3	69
30	20	1.5	90
19.2	12	1.6	140
13.2	12	1.1	204
10.2	6	1.7	264
5.2	4	1.3	519
3.0	2	1.5	900
1.32 ^[a]	1.2	1.1	1400

[a] There is a general PGA-input range constraint to support V_{INDIFF} of ± 700 mV at maximum, which is especially dominating for $G_{AMP} < 2$.

6.2.2. Analog-to-Digital Converter (ADC)

An analog-to-digital converter (ADC) is used to digitize the amplifier signal. To allow optimizing the trade-off between conversion time and resolution, the resolution can be programmed from 12-bit to 24-bit (*adc_bits* bit fields in the *SM_config1*, and *extTemp_config1* registers; see section 6.6.2.1). The ADC processes differential input signals around its input common mode level: V_{ADCmid} . Table 10 lists the ADC resolution, signal ranges, conversion times for a single Analog-to-Digital conversion.

Table 10. Single Analog-to-Digital Conversion

<i>adc_bits</i> [3:0]				ADC Resolution [Bits]	Ratiometric ADC Input Range ^[a] , $V_{ADC,IN}$ [V]	Absolute ADC Input Range ^[b] , $V_{ADC,IN}$ [V]	Conversion Time, Typical [μ s]	Conversion Rate, Typical [kHz]
Bit[3]	Bit[2]	Bit[1]	Bit[0]					
0	0	0	0	12	± 1.42	± 1.07	162	6.1
0	0	0	1	13	± 1.43	± 1.08	192	5.2
0	0	1	0	14	± 1.41	± 1.06	235	4.2
0	0	1	1	15	± 1.42	± 1.07	294	3.4
0	1	0	0	16	± 1.41	± 1.06	380	2.6
0	1	0	1	17	± 1.42	± 1.07	497	2.0
0	1	1	0	18	± 1.41	± 1.06	670	1.4
0	1	1	1	19	± 1.42	± 1.07	903	1.1
1	0	0	0	20	± 1.41	± 1.06	1245	0.8
1	0	0	1	21	± 1.42	± 1.07	1715	0.5
1	0	1	0	22	± 1.41	± 1.06	2400	0.4
1	0	1	1	23	± 1.42	± 1.07	3335	0.3
1	1	0	0	24	± 1.40	± 1.06	4705	0.2
1	1	0	1	Not assigned	–	–	–	–
1	1	1	0	Not assigned	–	–	–	–
1	1	1	1	Not assigned	–	–	–	–

[a] With the following settings: ratiometric reference, $sel_ref^* = 1$, and no ADC-shift ($adc_en_shift = 0$) nor extra ADC-gain, i.e. $Gain_{ADC}=1$

[b] With the following settings: absolute reference, $sel_ref^* = 0$, and no ADC-shift ($adc_en_shift = 0$) nor extra ADC-gain, i.e. $Gain_{ADC}=1$

The ADC can perform an additional offset shift (independent of the PGA shifting with $ioffsc$) in order to adapt input signals with offsets to the ADC input range. The shift feature is enabled by setting $adc_en_shift = 1$ (bit[8] in the $SM_config2$ or $extTemp_config2$ registers). As defined in Table 11, the respective analog offset shift can be selected with bits [14:12], adc_offset in $SM_config1$ or $extTemp_config1$.

Note: Enabling the offset shift causes the ADC to perform an additional amplification of the ADC's input signal by factor 2. This must be considered for a correct analog sensor setup by means of the PGA's gain, the absolute offset shift in the PGA, the ADC offset shift, and the potential ADC gain.

The overall analog amplification $Gain_{TOTAL} = Gain_{PGA} \cdot Gain_{ADC}$ can be determined for the following potential use cases using Equation 2 or Equation 3 depending on the ADC offset setting:

If no ADC offset shift is selected, i.e., $adc_en_shift = 0$ and $adc_offset = 000$, then

$$Gain_{TOTAL} = Gain_{PGA} \cdot 1 \quad \text{Equation 2}$$

If ADC offset shift is selected, i.e., $adc_en_shift = 1$ (adc_offset is configurable), then

$$Gain_{TOTAL} = Gain_{PGA} \cdot 2 \quad \text{Equation 3}$$

Table 11. ADC Offset Shift

<i>adc_offset</i> [2:0]			Compensation of Percentage Offset in Input Signal	ADC Input Signal Range [$V_{ADC,IN}$]
bit[2]	bit[1]	bit[0]		
0	0	0	0%	-0.5 to 0.5
0	0	1	6.25%	-0.44 to 0.56
0	1	0	12.50%	-0.38 to 0.62
0	1	1	18.75%	-0.31 to 0.69
1	0	0	25.00%	-0.25 to 0.75
1	0	1	31.25%	-0.19 to 0.81
1	1	0	37.50%	-0.13 to 0.87
1	1	1	44.00%	-0.06 to 0.94
ADC-offset shift disabled, $adc_en_shift = 0$			0% (compensation, $\times 2$ -gain off)	-1 to +1

6.2.3. Internal Temperature Sensor

The ZSSC3240 provides an internal temperature sensor measurement to allow compensation for temperature effects. The temperature output signal is a differential voltage that is adapted by the amplifier (PGA) for the ADC input, comparable to the external sensor's signal. For ZSSC3240-internal temperature measurements, the respective settings are defined and programmed in the NVM by Renesas.

6.2.4. Supported Supplies for Sensor Elements and Additional, External Temperature Sensing

There are two options to supply and bias the external sensor element, which can be selected by the *sensor_sup* bit field in the *SSF1* register (03_{HEX}) in the NVM (see Table 34). The differential sensor signal (e.g., from a sensor bridge) is fed into the ZSSC3240 at the INP pin for the positive and the INN pin for the negative signal level.

Table 12. Sensor Supply Options

<i>sensor_sup</i> [1:0]		External Sensor Supply
bit[1]	bit[0]	
0	0	Ratiometric voltage: VDDB to VSSB. ^[a]
0	1	Bias current out of VDDB. ^[a]
1	0	No supply, INN internally connected to AGND, absolute voltage-source measurement (e.g., thermopile between INP and INN).
1	1	Not assigned.

[a] The combination of settings *temp_source* = 100 and *sensor_sup*=01 returns the sensor to be supplied by a ratiometric voltage.

There are multiple possible combinations of an external main sensing supply and the SSC-input signal generation with different sensing elements and approaches for generating a temperature signal for temperature-dependency compensation. Table 13 illustrates the possible sensor connections, application circuits, and ZSSC3240 configurations.

Note: The applications circuits S1 to S3 and T1 to T5 highlight the supply paths in blue and the input signal paths in red for the main sensing element connection and supply in Table 13 and for the supporting, external temperature sensing in Table 15.

Table 13. Sensor Supply – Main Sensing

Application	Front-End Configuration, Sensor Application, and Connection Circuit	Setup and Remarks
S0		<p>General sensor front-end overview for main and supporting temperature sensor connection and setup</p>
S1		<p>Ratiometric bridge-type sensor setup:</p> <ul style="list-style-type: none"> • Sensor element supplied through an ZSSC3240-internal, regulated voltage • $sensor_sup = 00_{BIN}$ • Could also be combined with the internal temperature sensor or any external temperature sensor configuration using a ratiometric supply <p>Note: if $temp_source = 100_{BIN}$ (temperature application T3.2) is also set up, the $sensor_sup = 01_{BIN}$ must be configured in order to get the S1 application functionality.</p>
S2		<p>Current Mode bridge-type sensor setup:</p> <ul style="list-style-type: none"> • Sensor element biased through an ZSSC3240-internal current source via VDDB pad • $sensor_sup = 01_{BIN}$ • Could also be combined with the internal temperature sensor or any external temperature sensor configuration using the Current Mode supply
S3		<p>Absolute-voltage sensor setup:</p> <ul style="list-style-type: none"> • Sensor element not supplied • $sensor_sup = 10_{BIN}$ • Could also be combined with the internal temperature sensor ($temp_source = 000_{BIN}$) or an external single-diode temperature sensor configuration in Current Mode ($temp_source = 100_{BIN}$) <p>Note: Only up to a maximum of 50% of the input dynamic range is useable in this configuration</p>

For a ratiometric sensor supply, the $VDDA_{int}$ voltage from the ZSSC3240-internal regulator is used. As defined in Table 14, the alternative sensor bias current source generates a bias current that is programmable with the $T_{biasout}$ in bit field in the $*_config2$ registers (see Table 34).

Table 14. Sensor Bias Currents – Sensor Sourcing in Current Mode

Tbiasout			Nominal Sensor Bias Current [μA]
bit[2]	bit[1]	bit[0]	
0	0	0	5
0	0	1	10
0	1	0	20
0	1	1	39
1	0	0	79
1	0	1	157
1	1	0	196
1	1	1	494

The ZSSC3240 supports internal and external temperature sensing for sensor-signal conditioning (SSC) purposes; i.e. an extra, separate temperature measurement in order to compensate temperature effects in the measurand signal from the main sensing element; e.g., a pressure sensor. The respective setup must be configured via the *temp_source* bit field in the *SSF1* register.

If the main sensing element itself with its inherent temperature sensitivity is used to generate the temperature information for SSC correction, then the *internal_rt* and *extra_rt* bit fields in the *SFF1* register must be programmed. Table 15 provides an overview for the some of the supported temperature measurement options. The internal resistors *R_t* and *R_t'* have been designed for flat, almost zero-sensitivity to temperature, such that the resulting temperature sensor measurements' characteristic is mainly dominated only by the (typically spurious) temperature characteristic of the main sensor element itself. The use of the bottom resistance *R_t'*, selectable by *extra_rt*, is recommended for most related applications in order to have a bridge-resistance-related, symmetric temperature excitation, and not to introduce further differential signal offset when using the bridge-sensor element as the temperature sensor.

In any configuration, the constraints for the minimum/maximum absolute and differential input signal dynamics must be considered.

Table 15. Sensor Supply – Temperature Sensing

Application	Front-End Configuration, Temperature Sensor Application, and Connection Circuit	Setup and Comments
T1		<p>Bridge as the temperature sensor with the internal <i>R_t</i> in Current Mode</p> <ul style="list-style-type: none"> • Sensor element supplied through the ZSSC3240-internal bias; i.e., the current source • <i>temp_source</i> = 001_{BIN} • <i>internal_rt</i> = User selected • <i>extra_rt</i> = 0_{BIN} <p>Note: Only combine this T1 application with <i>sensor_sup</i> = 01_{BIN} (i.e., main sensing application S2 in Table 13)</p>

Application	Front-End Configuration, Temperature Sensor Application, and Connection Circuit	Setup and Comments
T2		<p>Bridge as temperature sensor with an external R_t in Current Mode:</p> <ul style="list-style-type: none"> • Sensor element supplied through the ZSSC3240-internal bias, i.e. the current source • $temp_source = 010_{BIN}$ • $internal_rt =$ value close to $R_{t,external}$ • $extra_rt = 0_{BIN}$ <p>Note: Only combine this T2 application with $sensor_sup = 01_{BIN}$ (i.e., main sensing application S2 in Table 13)</p>
T3.1		<p>Separate diode / PTC-resistor as temperature sensor in Current Mode:</p> <ul style="list-style-type: none"> • Sensor element supplied through the ZSSC3240-internal bias, i.e. the current source • $temp_source = 100_{BIN}$ • $internal_rt = any$ • $extra_rt = 0_{BIN}$ and $sensor_sup = 10_{BIN}$ (no R_t and absolute voltage sensor, i.e. main sensing application S3) • $sel_ref2 = 0_{BIN}$ must be selected <p>Note: The voltage at T_{EXT} must fulfill input conditions and must be in the range of 0.5V to 1.25V</p>
T3.2		<p>Separate diode / PTC-resistor as temperature sensor in Current Mode:</p> <ul style="list-style-type: none"> • Sensor element supplied through the ZSSC3240-internal bias, i.e. the current source • $temp_source = 100_{BIN}$ • $internal_rt = any$ • $extra_rt = 0_{BIN}$ and $sensor_sup = 01_{BIN}$ (different from other application cases, R_t is connected here and the Main Sensor Bridge is supplied ratiometrically, i.e. main sensing application S1) • $sel_ref2 = 0_{BIN}$ must be selected <p>Note: The voltage at T_{EXT} must fulfill input conditions and must be in the range of 0.5V to 1.25V</p>

Application	Front-End Configuration, Temperature Sensor Application, and Connection Circuit	Setup and Comments
T4		<p>Temperature sensor with internal R_t with ratiometric supply</p> <ul style="list-style-type: none"> • Sensor element supplied through the ZSSC3240-internal regulated voltage VDDA, i.e. ratiometric supply • $temp_source = 101_{BIN}$ • $internal_rt =$ User selected • $extra_rt = 0_{BIN}$ <p>Note: Only combine this T4 application with $sensor_sup = 00_{BIN}$ (i.e., main sensing application S1 in Table 13)</p>
T5		<p>Temperature Sensor with external R_t with ratiometric supply</p> <ul style="list-style-type: none"> • Sensor element supplied through the ZSSC3240-internal regulated voltage VDDA; i.e., the ratiometric supply • $temp_source = 110_{BIN}$ • $internal_rt =$ any value close to the external R_t value • $extra_rt = 0_{BIN}$ <p>Note: Only combine this T5 application with $sensor_sup = 00_{BIN}$ only (i.e., main sensing application S1 in Table 13)</p>

When using scenario T1, “Bridge as the temperature sensor with the internal R_t in Current Mode” in Table 15, the setup for bias current (I_{sup}) and internal R_t must fulfill the requirements given in Equation 4 and Equation 5:

$$(0.5 \cdot R_{sens} + R_t) \cdot I_{sup} = 0.85V \pm 125mV \tag{Equation 4}$$

Where R_{sens} is the nominal resistance of the sensor element; i.e. the typical, effective resistance generating the differential sensor signal as input to the INP and INN pads.

Important: Take into consideration the maximum specifications for the PGA common mode input level, V_{Cmin} (see Table 4).

$$(MAX[R_{sens}] - MIN[R_{sens}]) \cdot I_{sup} < 700mV \tag{Equation 5}$$

Important: Take into consideration the maximum specifications for the input signal, $MAX[V_{DIFFin}]$ (see Table 4).

The best method for deriving the respective values for R_t and I_{sup} is to choose an R_t value close to but greater than R_{sens} and to calculate I_{sup} accordingly.

When using scenario T4, “Temperature sensor with internal R_t with ratiometric supply,” in Table 15 the setup for bias current (I_{sup}) and internal R_t must fulfill Equation 6:

Important: Take into consideration the maximum specifications for the PGA common mode input level, V_{Cmin} , which is automatically ensured if R_t and the extra R_t are selected.

$$(\text{MAX}[R_{\text{sens}}] - \text{MIN}[R_{\text{sens}}]) / (R_{\text{sens}} + 2 \cdot R_t) \cdot V_{\text{DDB}_{\text{typ}}} < 700\text{mV}$$

Equation 6

Important: Take into consideration the maximum specifications for the input signal, $\text{MAX}[V_{\text{DIFFin}}]$ with $V_{\text{DDB}_{\text{typ}}} = 1.85\text{V}$.

In most cases, a low R_t value will suffice for ratiometrically supplied configurations. The lower the applied R_t value, the less the noise-level effect onto the temperature measurement signal.

Sensor-bridge elements, which already contain a top resistor for temperature sensing purposes, can use the internal extra R_t .

6.3 On-Chip Diagnostics

The ZSSC3240 offers analog and digital self-test and sensor-diagnostic features to ensure robust system operation. If the part is programmed and operated with analog output ($\text{cont_ANAoutn} = 0_{\text{BIN}}$ in the *SSF2* register; see Table 34), then diagnostic states are indicated by upper and lower levels at the AOUT pin; see Table 16. With the SPI, I2C, and OWI digital interfaces, the default status byte contains fault-diagnostics information. If further detailed diagnostic information is required, the *CHECK_DIAG* command B0_{HEX} must be issued to retrieve the detailed diagnostics' results in the *diagnosticreg* output register. The content of *diagnosticreg* (see Table 17) is updated each time new respective diagnostic information becomes available. This is also the case with the default ZSSC3240 initialization after power-on-reset (POR) or if specific commands are triggered in order to perform diagnostic checks or influence *diagnosticreg*:

RESET_DIAG, B1_{HEX} Resets the contents of *diagnosticreg*.

UPDATE_DIAG, B2_{HEX} Performs all enabled diagnostic checks (selected via the *select_checks* bit field [9:0] in register 21_{HEX} in NVM; see Table 34) and default diagnostic checks including checksum validation of the NVM; results in complete update of *diagnosticreg*.

Connection Checks These are scheduled connection checks in the Cyclic Mode setup. All enabled checks (as selected with *select_checks*) are performed, and *diagnosticreg* is updated accordingly.

The analog signalization of diagnostic states at the AOUT pin for the different analog output options can be enabled/disabled via the *diagouten* bit in the *SSF2* register 04_{HEX} in the NVM (see Table 34). In Cyclic Mode, the analog signalization of a diagnostic state is present with the *SSC Calculation and Output Update* phase of the same measurement slot; see section 6.5.2. In Command Mode (with enabled analog output at AOUT pin), the diagnostic state at AOUT will be present with completion of the next SSC-conversion command, i.e. AA_{HEX} or AC_{HEX} to AF_{HEX} ; see Table 33).

Table 16. Diagnostic Signalization Options with ZSSC3240

Detected Fault	Analog Ratiometric Diagnostic Level, AOUT ^[a]	Analog Absolute Diagnostic Level, AOUT ^[a]	OWI, SPI, I2C Status Byte [7:0]	Comments
No Error / Fault	2.5% to 97.5%	0.125 to 4.875 V ^[b] 0.025 to 0.975 V ^[c]	$\text{01XX X000}_{\text{BIN}}$	Status after "reset."
Memory Error	Lower	0 to 0.125 V ^[b] 0 to 0.03 V ^[c]	$\text{0XXX X1XX}_{\text{BIN}}$	Checksum failure of NVM.
Loss of INP Connection, INP Open	Upper	4.875 V to VDD ^[b] 0.975 to 1.0 V ^[c]	$\text{0XXXXX1X}_{\text{BIN}}$	A detailed, digital decoding of the respective connection check fault can be fetched using the B0_{HEX} <i>CHECK_DIAG</i> command, which returns the <i>diagnosticreg</i> register content.
Loss of INN Connection, INN Open	Upper	4.875 V to VDD ^[b] 0.975 to 1.0 V ^[c]		
INN or INP Signals Out of Range	Upper	4.875 V to VDD ^[b] 0.975 to 1.0 V ^[c]		
Bridge/Sensor Short (INN = INP)	Upper	4.875 V to VDD ^[b] 0.975 to 1.0 V ^[c]		
T_ext Pin Open	Lower	0 to 0.125 V ^[b] 0 to 0.03 V ^[c]		

Detected Fault	Analog Ratiometric Diagnostic Level, AOUT [a]	Analog Absolute Diagnostic Level, AOUT [a]	OWI, SPI, I2C Status Byte [7:0]	Comments
T_ext Pin Out of Range	Lower	0 to 0.125 V [b] 0 to 0.03 V [c]		
T_ext Pin Short to INP	Lower	0 to 0.125 V [b] 0 to 0.03 V [c]		
T_ext Pin Short to INN	Lower	0 to 0.125 V [b] 0 to 0.03 V [c]		
Die Crack / Chipping Check	Lower	0 to 0.125 V [b] 0 to 0.03 V [c]		
SSC Calculation Unit Saturation	Upper (extra)	4.875 V to VDD [b] 0.975 to 1.0 V [c]	0XXX XXX1 _{BIN}	

- [a] Only signalized if *diagouten* = 1_{BIN}.
- [b] With VDD = 5V ±10%, for 0 to 5V absolute analog out.
- [c] With any VDD, for 0 to 1V absolute analog out.

If multiple failures are detected leading to analog outputs that would be contradictory to each other, the high signal is always provided. The effective absolute, analog diagnostic-output level is constant for lower and upper diagnostic signal output. This absolute level may vary from IC to IC slightly. Hence, the effective lower and upper level for the absolute AOUT signal in the event of a valid diagnostic and failure event, respectively, are not influenced by any diagnostic-related setup in NVM nor by calibration coefficients, etc., per the *Aout_setup* bit field in register 04_{HEX} in NVM (see Table 34). However, the threshold (i.e., the sensor-signal-valid maximum for the upper and minimum for the lower diagnostic band) can be programmed and adjusted via proper calibration and the *diagouten* bit in register 04_{HEX}.

Table 17. Information Assignment for CHECK_DIAG Command: Output Register *diagnosticreg* [15:0]

Meaning	Connection Check Content	DAC Output [a]	Bit-Number															
			15	14	13	12	11	10	9	8	7	6	5	4	3	2	1	0
No Error / Fault	Yes	From SSC	0	0	0	0	0	0	0	0	0	0	0	0	0	0	0	0
Fault information improved since last status information	Yes	–	0	0	0	0	0	0	0	0	0	0	0	0	0	0	0	1
Loss of sensor positive connection, INP	Yes	2daces – 7	0	0	0	0	0	0	0	0	0	0	0	0	0	0	1	0
Loss of sensor negative connection, INN	Yes	2daces – 7	0	0	0	0	0	0	0	0	0	0	0	0	0	1	0	0
Signal at INP pin out of range (leaking / short to VSS or VDDB)	Yes	2daces – 7	0	0	0	0	0	0	0	0	0	0	0	0	1	0	0	0
Signal at INN pin out of range (leaking / short to VSS or VDDB)	Yes	2daces – 7	0	0	0	0	0	0	0	0	0	0	0	1	0	0	0	0
Sensor short (INN = INP)	Yes	2daces – 7	0	0	0	0	0	0	0	0	0	0	1	0	0	0	0	0
TEXT pin open	Yes	0007 _{HEX}	0	0	0	0	0	0	0	0	0	1	0	0	0	0	0	0
Signal at TEXT pin out of range (leaking / short to VSS or VDDB)	Yes	0007 _{HEX}	0	0	0	0	0	0	0	0	1	0	0	0	0	0	0	0
TEXT pin short to INN	Yes	0007 _{HEX}	0	0	0	0	0	0	0	1	0	0	0	0	0	0	0	0
SSC Calculation Unit saturation	No	2daces – 7	0	0	0	0	0	0	1	0	0	0	0	0	0	0	0	0
Memory error, checksum-check failure	No	0007 _{HEX}	0	0	0	0	0	1	0	0	0	0	0	0	0	0	0	0
TEXT pin short to INP	Yes	0007 _{HEX}	0	0	0	0	1	0	0	0	0	0	0	0	0	0	0	0
Die crack / chipping check failure	No	0007 _{HEX}	0	0	1	0	0	0	0	0	0	0	0	0	0	0	0	0

- [a] The effective low limit for the DAC and resulting AOUT output signaling scales with the set up DAC resolution and is 16-bit = 0007_{HEX}, 15-bit = 000E_{HEX}, 14-bit = 0015_{HEX}, or 13-bit = 001C_{HEX}.

If a bit reset, i.e. a change from 1_{BIN} (FAULT) back to 0_{BIN} (NO-FAULT), for any bit occurs, *diagnosticreg*[0] is set in order to signal an improvement of fault states during the ZSSC3240 operation. This is especially relevant for Cyclic Mode and Continuous Analog-Output Mode operation.

The *select_checks* bit field in NVM register 21_{HEX}¹ can be programmed to select which (analog) checks are executed and/or signaled when the *UPDATE_DIAG* command is triggered or when a connection check is performed during Cyclic Mode operation. Checks that are not selected do not result in *diagnosticreg* register updates and are not signaled at the DAC and AOUT output.

6.4 Digital Interfaces

The ZSSC3240 supports three different digital interface protocols: SPI, I2C, and OWI. The implementation of the interfaces is such that the available commands (section 6.6.1) and request codes for the ZSSC3240 are the same regardless on the interface type used.

The selection of whether the ZSSC3240 operates with SPI, I2C, or OWI interface is determined in the start-up phase after power-on. Initially all interface relevant parameters are loaded from address 02_{HEX} in the NVM (slave address, SPI configuration). If the first command after power-on is a valid and properly formatted I2C request including the correct slave address, the interface is fixed as an I2C slave. If, instead, there is an active signal at the SS pin as the first valid activity, then the IC is fixed as an SPI slave. Alternatively, a valid OWI start (within the start-up window) will fix the interface as OWI. Once, the interface is established and fixed, a change of the interface can only be done by means of a power-on-reset. The status byte defined in Table 18 is common for all supported interface types, and it is part of the ZSSC3240's digital response to read requests.

Table 18. General Status Byte

Bit-Number	7	6	5	4	3	2	1	0
Meaning	0	Powered?	Busy?	Mode		Memory Error?	Connection Check Fault?	Math Saturation

Table 19. Mode Status

Status[4:3]	Mode
00	Command Mode
01	Cyclic Mode
10	Sleep Mode
11	Renesas reserved

6.4.1. SPI

The SPI interface mode is available if the first interface activity after ZSSC3240 power-up is an active signal at the SS pin. The polarity and phase of the SPI clock are programmable via the *CKP_CKE* setting in bits [11:10] in address 02_{HEX} as described in Table 34. *CKP_CKE* is two bits: *CPHA* (bit 10), which selects which edge of SCLK latches data, and *CPOL* (bit 11), which indicates whether SCLK is high or low when it is idle. The polarity of the SS signal and pin are programmable via the *SS_polarity* setting (bit 9).

The different combinations of polarity and phase are illustrated in Figure 5 and Figure 6. See Table 20 for the timing parameters.

¹ Recommendation for current loop applications: To minimize the effect of varying current draw in current loop applications, do not perform short-connection checks (*sens_short_check*, *text_inn_short_check*, *text_inp_short_check*).

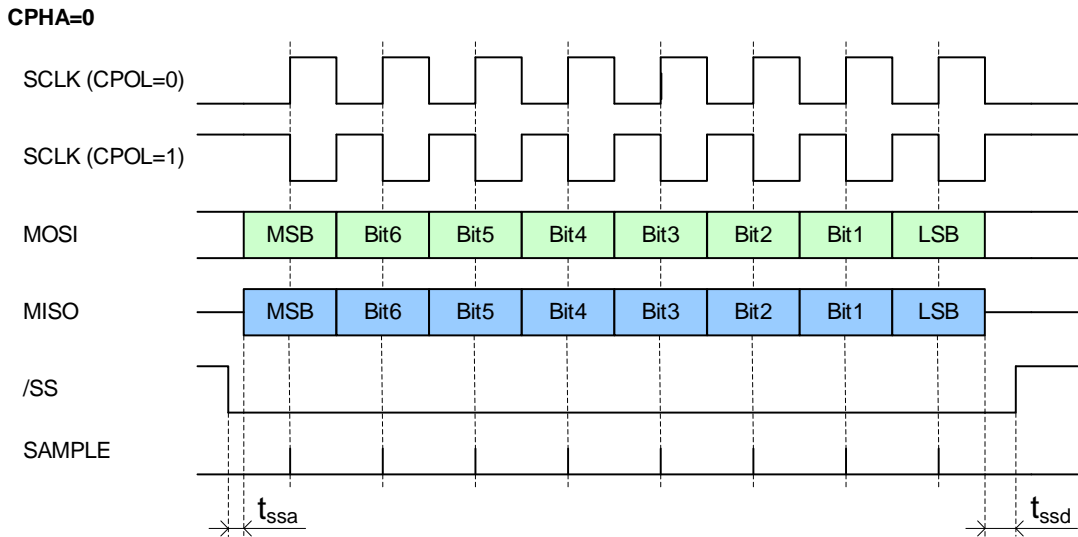

Figure 5. SPI Configuration CPHA=0

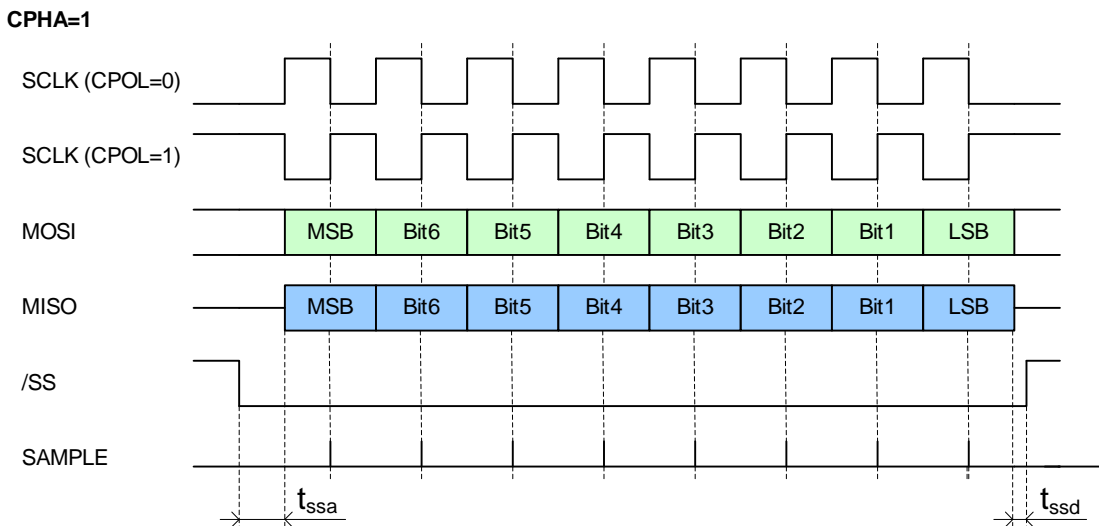

Figure 6. SPI Configuration CPHA=1

In SPI Mode, each command except NOP is started as shown in Figure 7. After the execution of a command (busy = 0), the expected data can be read as illustrated in Figure 8 or if no data are returned by the command, the next command can be sent. The status can be read at any time with the *NOP* command (see Figure 9).

Note: If SS and SCLK do not end after one complete read-response cycle, but continue for any reason, the ZSSC3240 will start repeating; e.g. the measurement result data would repeat in the following sequence (comparable to the OWI response shown in Figure 17):

Status → SensorData [23:16] → SensorData [15:8] → SensorData [7:0] → TempData[23:16] → TempData[15:8] → TempData[7:0] → SensorData [23:16] → SensorData [15:8] →...

Command Request

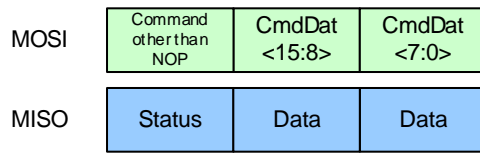

Note: A command request always consists of 3 bytes. If the command is shorter, then it must be completed with 0's. The data on MISO depend on the preceding command.

Figure 7. SPI Command Request

Read Data

(a) Example: after the completion of a *Memory Read* command

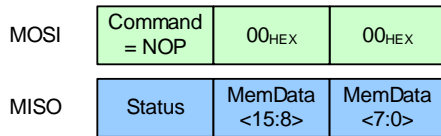

(b) Example: after the completion of a *Measure* command (AA_{HEX})

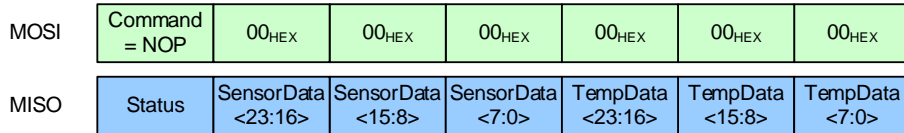

Figure 8. SPI Read Data

Read Status

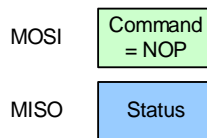

Figure 9. SPI Read Status

Table 20. SPI Interface Parameter

Note: See important table notes at the end of the table.

Symbol	Parameter	Conditions	Minimum	Typical	Maximum	Units
f _{SCLK}	Interface clock		0.05	1	12	MHz
D _{SPI}	Duty cycle		40	50	60	%
V _{high,SPI}	Input high level voltage	Referenced to external supply voltage V _{DD} (maximum 5.5V)	0.7	–	1.0	V _{DD}
V _{low,SPI}	Input low level voltage		0.0	–	0.3	V _{DD}
SR _{SPI}	Input rising and falling edge slew rate		0.26	–	1	V/ns
t _{ssa}	Delay time [a] between SS-activation edge and first edge of SLCK, MOSI or MISO	"Typical" is for f _{SCLK} ≤ 3MHz operation	1	50	–	ns
t _{ssd}	Delay time [a] between SS-deactivation edge and last edge of SLCK, MOSI or MISO		1	50	–	ns
t _{ss}	Delay between SS-deactivation edge of last command and of SS-activation edge for next command		10	–	–	μs
I _{MISO}	Driving current of SPI output (peak)		–	40	180	mA

[a] Typical: For conditions with no clocks prior and after the command and data bytes, the maximum values for t_{ssa} and t_{ssd} are not relevant; under conditions with clocks prior to and after command and data, there is a maximum for t_{ssa} and t_{ssd} = 0.3/f_{SCLK}.

6.4.2. I2C

I2C Mode is selected if the first interface activity after the ZSSC3240 power-up is an I2C command with valid slave address. In I2C Mode, each command is started as shown in Figure 10. Only the number of bytes that are needed for the command must be sent. An exception is the I2C High Speed Mode where 3 bytes must always be sent as in SPI Mode. After the execution of a command (busy = 0), the expected data can be read as illustrated in Figure 11 or if no data are returned by the command, the next command can be sent. The status can be read at any time as described in Figure 12.

Command Request (IC Write)

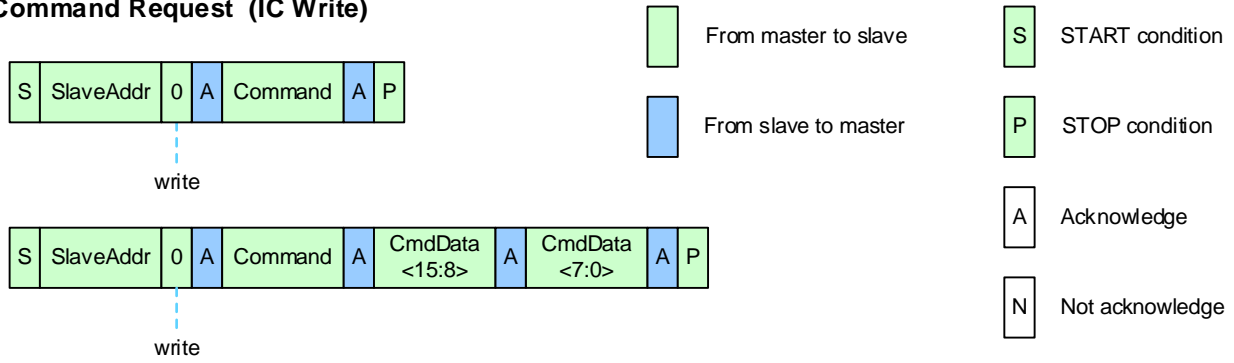
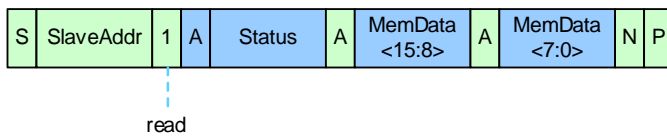

Figure 10. I2C Command Request

Read Data (I2C Read)

(a) Example: after the completion of a Memory Read command



(b) Example: after the completion of a **Measure** command (AA_{HEX})

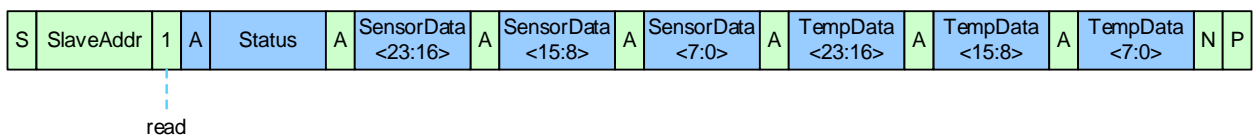

Figure 11. I2C Read Data

Read Status (I2C Read)

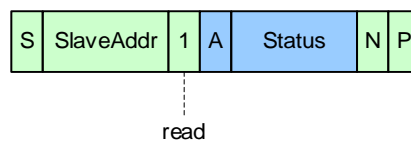

Figure 12. I2C Read Status

Table 21. I2C Interface Parameter

Symbol	Parameter	Conditions	Minimum	Typical	Maximum	Units
f _{SCL}	Interface clock		0.1	–	3.4	MHz
D _{SPI}	Duty cycle		33	–	50	%
V _{high,SPI}	Input high level voltage	Referenced to external supply voltage V _{DD} .	0.7	–	1.0	V _{DD}
V _{low,SPI}	Input low level voltage		0.0	–	0.3	V _{DD}

Symbol	Parameter	Conditions	Minimum	Typical	Maximum	Units
C_{SDA}	Capacitive load at input pin, SDA	100pF: maximum for Standard and Fast Mode; in HS Mode $f_{SCL,max} = 3.4\text{MHz}$ 400pF: only in HS Mode; $f_{SCL,max} = 1.7\text{MHz}$	–	100	400	pF
I_{OL}	Low level output current	$V_{SDA}=0.4\text{V}$; Standard and Fast Mode with 400kHz; 400pF load	3	6	40	mA

Details for timing and protocol of the ZSSC3240-supported I2C communication in Standard Mode, Fast Mode, and High-Speed Mode are given in *I2C-Bus Specification, Rev.6, UM10204*.

6.4.3. One-Wire-Interface, OWI

The ZSSC3240 employs a one-wire digital interface concept (OWI). It combines a simple and easy protocol adaptation with a cost-saving pin sharing. The communication principle of the OWI interface is derived from the I2C protocol.

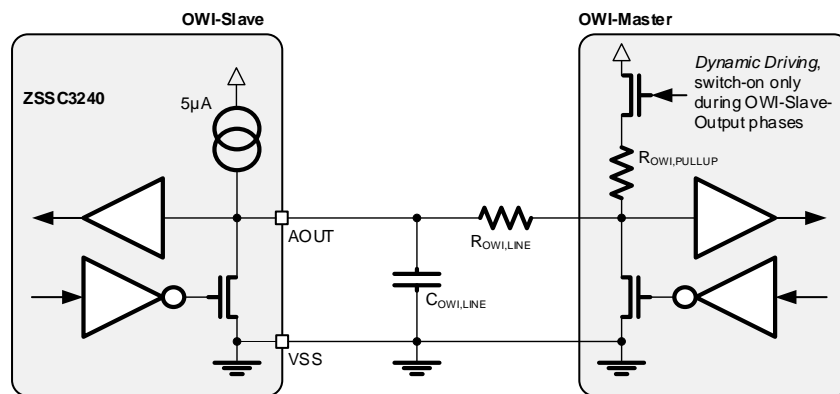

Figure 13. General Block Schematic of the OWI Interface

Both the analog output signal and the digital OWI interface use the same pin, AOUT. An advantage of the OWI is that it enables “end of line” calibration – no additional pins are required to digitally calibrate a finished assembly. Although the OWI is integrated mainly for calibration, it can also be used to read out the calibrated sensor signal continuously or retrieve diagnostic detail information.

The OWI protocol is defined as follows:

- **Idle State:** During inactivity of the bus, the OWI line is pulled up to the supply voltage V_{DD} by an external resistor.
- **Start Condition:** When the OWI line is in idle mode, a low pulse with a minimum width of $t_{OWI,START} \geq 10\mu\text{s}$ and then a return to high indicates a start condition. Every request must be initiated by a start condition sent by a master. A master can generate a start condition only when the OWI line is in idle mode.
- **Valid Data:** Data is transmitted in bytes (8 bits) starting with the most significant bit (MSB). Transmitted bits are recognized after a start condition at every transition from low to high at the OWI line. The value of the transmitted bit depends on the duty ratio between the high phase and high/low period (bit period, $t_{OWI,BIT}$ in Figure 14). A duty ratio greater than $1/8$ and less than $3/8$ is detected as 0; a duty ratio greater than $5/8$ and less than $7/8$ is detected as 1. The bit period of consecutive bits must not increase to more than 1.5 times the previous bit period or decrease to less than half of the previous bit period because a stop condition is detected in this case.

The length of the OWI-line and the size of $R_{OWI,PULL}$ (if it is statically connected to AOUT), and consequently the resistive and capacitive load influence the maximum possible interface speed and minimum Bit period, respectively. Further, it can be beneficial for harsh EMC conditions to intentionally add capacitance to the OWI1 (AOUT) line in order to improve RF disturbance robustness. Table 22 shows some practical OWI-interface dimensioning examples and the resulting maximum signal frequencies (minimum possible Bit periods). The complete ZSSC3240's OWI interface properties and timing capabilities are given in Table 23.

Table 22. OWI Dimensioning Examples

$R_{OWI,PULL}$ (+ $R_{OWI,LOAD}$)	1.8 kΩ	2.5 kΩ	3.3 kΩ	5.5 kΩ	10.0 kΩ
$C_{OWI,LOAD}$ [a]					
1nF	20μs	20μs	21μs	35μs	63μs
10nF	113μs	157μs	207μs	345μs	628μs
22nF	249μs	345μs	456μs	760μs	1381μs
33nF	373μs	518μs	684μs	1140μs	2070μs
44nF	497μs	691μs	912μs	1520μs	2762μs
51nF	576μs	801μs	1057μs	1760μs	3205μs

[a] Examples are shown with statically connected $R_{OWI,PULL}$, and with minimum bit period: $t_{OWI,BIT}$.

OWI protocol timing and parameters are specified in Figure 14, Figure 15, and Table 23.

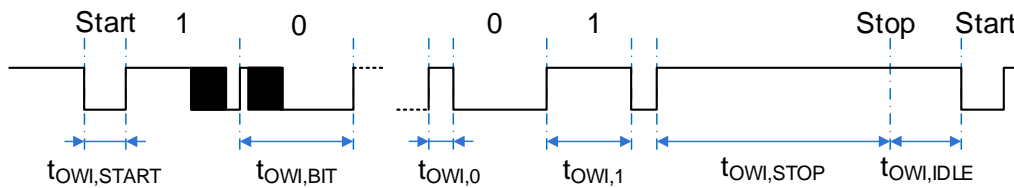

Figure 14. OWI Timing Diagram

Note: Configuration for *SSF1* register 03_{HEX} in NVM (see Table 34) to allow continuous OWI and concurrent analog output: *owi_off* = 0, *cont_ANAoutn* = 0, *owi_su_case* = 1.

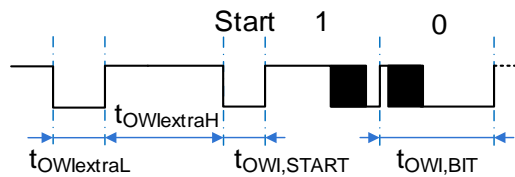

Figure 15. OWI Extra (Activation) Pulse for Concurrent OWI and Analog Output Configuration

Table 23. OWI Interface Parameters

Symbol	Parameter	Conditions	Minimum	Typical	Maximum	Units
$t_{SU,length}$	OWI start-up “listening” window	Programmable window length, see <i>owi_su_length</i> , bit[2] in <i>SSF1</i> register	–	–	50	ms
$t_{OWI,IDLE}$	Bus free time between START and STOP condition	For Cyclic and Command Mode operation	1	30	–	μs
		Minimum in ZSSC3240 Sleep Mode operation	20			
$t_{OWI,START}$	Hold time for START condition		20μs	$0.5 \times t_{OWI,BIT}$	–	μs
$t_{OWI,BIT}$	Bit period, bit time	Robust operation with: $t_{OWI,BIT} \geq 10 \cdot R_{OWI,PULL} \cdot C_{OWI,LOAD}$	20	40	3000	μs
$t_{OWI,BIT}$	Bit period, bit time	Robust operation with: $t_{OWI,BIT} \geq 10 \cdot R_{OWI,PULL} \cdot C_{OWI,LOAD}$	20	40	3000	μs
$t_{OWI,0}$	Duty ratio bit ‘0’		0.125	0.25	0.375	$t_{OWI,BIT}$
$t_{OWI,1}$	Duty ratio bit ‘1’		0.625	0.75	0.875	$t_{OWI,BIT}$
$t_{OWI,STOP}$	Hold time STOP condition	$t_{OWI,BIT,L}$ is the bit period of the last valid bit	1.5	3	–	$t_{OWI,BIT,L}$
$t_{OWI,BIT,DEV}$	Bit time deviation	Duration of most recent bit versus previous bit duration	0.55	1.0	1.45	$t_{OWI,BIT}$
$t_{OWI,extraL}$	Length of extra pulse [a]	OWI configuration to allow continuous OWI and concurrent analog output; see Figure 15.	43.5	–	49.5	μs
$t_{OWI,extraH}$	Duration of HIGH after Aout-to-OWI extra pulse		43.5	–	–	μs

Symbol	Parameter	Conditions	Minimum	Typical	Maximum	Units
C _{OWI,LOAD}	Capacitive load at OWI line	Minimize C _{OWI,LOAD} if ratiometric DAC-output, <i>Aout_setup</i> = 001 _{BIN} is configured for AOUT/OWI1	0.05	2.2	66	nF
R _{OWI,PULL}	Pull-up resistance – master ^[a]	If R _{OWI,PULL} values greater than 3.3kΩ were applied, the shortest t _{OWI,BIT} times cannot be achieved anymore.	1.8	2.5	3.3	kΩ
R _{OWI,LOAD}	Resistive OWI line load	If R _{OWI,LOAD} >35Ω, OWI-timing parameter (t _{OWI,-}) low-limits, i.e. highest speeds are not guaranteed.	0	0.01 x R _{OWI,PULL}	–	Ω
V _{OWI,inL}	Voltage level LOW		–	0.1	0.25	VDD
V _{OWI,inH}	Voltage level HIGH		0.80	0.9	–	VDD
V _{OWI-S,LOW}	Slave output level LOW	Open drain output at AOUT pin, max. allowed current draw 5mA, otherwise: V _{OWI-S,LOW} >0.1*VDD	–	–	0.1	VDD

[a] To switch from analog output to “OWI listen” at AOUT pin.

[b] For the selection of R_{OWI,PULL}, the minimum current limit of the AOUT buffer and maximal VDD supply must take into account if OWI and analog output voltage mode are set up to work concurrently; that is *owi_off* = 0, *cont_ANAoutn* = 0, and *owi_su_case* = 1. If the current limitation condition (I_{OUT,max}, see Table 4) is exceeded, it is recommended to use the Dynamic Driving Approach for R_{OWI,PULL} at the OWI-master, and only switch the R_{OWI,PULL} to AOUT when the OWI-master starts communication. This setting is specifically recommended for the phases when the OWI-master listens to the AOUT-line, and the OWI-slave (the ZSSC3240) has to respond, respectively.

The effective OWI properties depend on the load conditions at the OWI1 pin. Additional to Table 22, some further applicable configurations are as follows:

- For maximum operation speed (50kHz) of OWI1, the capacitive load, C_{OWI,LOAD} can be up to 1nF and the maximum R_{OWI,PULL} is 2.5kΩ.
- For high operation speed (10kHz) of OWI1, the capacitive load, C_{OWI,LOAD} can be up to 4.7nF and R_{OWI,PULL} must be ≤ 3.3kΩ.
- For an equivalent frequency of 1kHz of OWI1, it should be ensured that C_{OWI,LOAD} ≤ 22nF and R_{OWI,PULL} ≤ 7kΩ, or for example that C_{OWI,LOAD} ≤ 66nF combined with R_{OWI,PULL} ≤ 4.5kΩ.

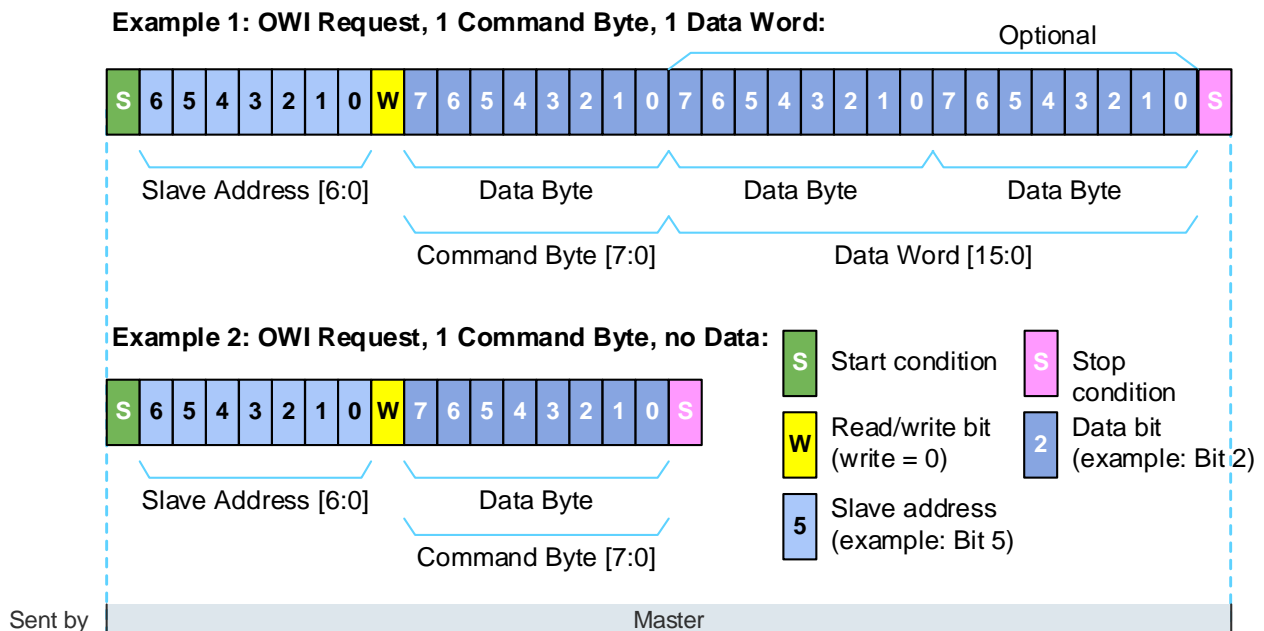

Figure 16. OWI Command Request

6.5 Measurement and Output Options

Sensor or diagnostic measurement results of the ZSSC3240 can be provided in both domains, digital and analog. Any of the supported digital interfaces and output options can be used as the only active interaction path, or it can be combined with any of the analog output configurations. For digital communication, only one interface type can be active and supported (see section 6.4).

Digital communication via SPI and I2C are fully independent of the configuration and application of the ZSSC3240's analog outputs. For digital OWI communication combined with analog output, special application circuits and constraints might have to be considered, as the OWI interface and the analog outputs use the same pin, AOUT.

6.5.1. Single Measurements, Digital Raw Results, and SSC Results

The IC generates digital raw values, which are processed by the ZSSC3240-internal math core generating the SSC-corrected (linearized, temperature-compensated) output signal. See section 6.6.3 for details about the SSC math, etc. In addition to the SSC-corrected digital measurement results, the ZSSC3240 can provide raw values without SSC correction for evaluation and/or calibration purposes. The respective results are provided at the digital interface as a 24-bit wide data word. Raw values and SSC results are MSB-aligned. Raw values are formatted as two's-complement, whereas SSC results are formatted as unsigned absolute value.

Table 24. Data Format of Raw ADC Readings

Bit-Number	23	22	21	20	...	2	1	0
Meaning, Weighting	-2^0	2^{-1}	2^{-2}	2^{-3}	...	2^{-21}	2^{-22}	2^{-23}

Table 25. Data Format of Corrected, SSC Results (S and T)

Bit-Number	23	22	21	20	...	2	1	0
Meaning, Weighting	2^0	2^{-1}	2^{-2}	2^{-3}	...	2^{-21}	2^{-22}	2^{-23}

The ZSSC3240 can process and digitize the following signals:

- *SM*: Direct sensor signal inputs; i.e., perform sensor measurements
- *AZS*: Auto-zero signals for the sensor channel
- *TM*: Direct temperature signal inputs, i.e. perform temperature measurements
- *AZT*: Auto-zero signals for the temperature channel

The internal sequence (in time) of A2D-conversions with both auto-zero measurements enabled is: first is *AZS*, second is *SM*, third is *AZT*, and forth is *TM*. The utilization of auto-zero measurements allows further optimization and reduction of the noise level for the sensor signal in combination with the inherent compensation of the residual offsets of the analog sensor front-end. If an auto-zero measurement is enabled, then the sensor signal remains the input for the auto-zero measurement with the gain and ADC set up as for the original signal measurement, but with swapped inputs and offset configurations of the PGA and ADC such that the following holds for the resulting raw value:

- Sensor raw value with auto-zero: $S_{raw} = 0.5 \cdot (SM - AZS)$
- Temperature raw value with auto-zero: $T_{raw} = 0.5 \cdot (TM - AZT)$

The application benefits with enabled auto-zero measurements are

- ZSSC3240 front-end offset cancellation – residual signal degradation¹ or drift for the application is eliminated
- Improvement of the signal-to-noise ratio for the raw or SSC-corrected output signal

¹ Worst-case IC-offset drift is < 2ppm/day at 125°C.

On the other hand, the default application benefit without auto-zero measurements is an approximately 50% faster output update rate compared to an equivalent configuration with enabled auto-zero measurements.

Recommendations: For applications where a faster update rate is the priority, disable and not apply the auto-zero measurements. For applications where a better signal-to-noise level and maximum signal quality are the priority, enable and apply the auto-zero measurements.

The NVM configuration and measurement-request commands can be used to select which measurements are performed, processed, and provided at the digital interface. See Table 33 for command details.

Examples of options for a single measurement request and output:

- SSC-corrected sensor readings (requested by the *Measure* command AA_{HEX}) generating an output of SSC-corrected, 24-bit sensor data followed by SSC-corrected, 24-bit temperature data.
- Raw sensor measurement with or without auto-zero correction (requested by the *Raw Sensor Measure* command A2_{HEX}) generating an output of raw 24-bit sensor data.
- Raw temperature measurement with or without auto-zero correction (requested by the *Raw Temperature Measure* command, A4_{HEX}) generating an output of raw 24-bit temperature data.

The auto-zero measurements can be disabled/enabled via the *AZMs_on* and *AZMt_on* bits in NVM registers 04_{HEX} (see Table 34).

Table 26 and Table 27 provide some exemplary, typical conversion times and noise performance values for the ZSSC3240's Front-End (PGA and ADC) in order provide some guidance for understanding effects and signal-quality-related consequences while defining an application setup.

Table 26. Typical Conversion Times for Complete SSC Sensor Measurements: SM, TM

ADC Resolution (Main) Sensor	ADC Resolution Temperature Sensor	Typical Measurement Duration [ms] ^[a]
12	12 (external temperature sensor)	0.38
14	13 (internal temperature sensor)	0.53
14	14 (external temperature sensor)	0.53
16	14 (external temperature sensor)	0.67
16	16 (external temperature sensor)	0.82
18	18 (external temperature sensor)	1.40
24	24 (external temperature sensor)	9.47

[a] The time from the end of the SSC-measurement command request AA_{HEX} to signalization for the end-of-conversion at the EOC pin with the ZSSC3240 in Command Mode; *INT_setup* bit field = 00_{BIN} in register 02_{HEX} (see Table 34); 25°C; V_{DD}=5V; *AZMs_on* = 0_{BIN}; and *AZMt_on* = 0_{BIN}.
The data is shown with ZSSC3240 default NVM configuration.

Table 27. Typical Conversion Times and Noise Performance for Complete SSC Measurements

ADC Resolution: External Sensor [Bits]	Reference Source for External Sensor (<i>sel_ref1</i>)	Typical 3-sigma Noise for SSC-Corrected (Digital) Output ^[b]	Typical Measurement ^{Error!} Duration ^[c] [ms] <small>Reference source not found.</small>
12	Absolute, <i>sel_ref1</i> =0	5 LSB _{12Bit}	1.3
12	Ratiometric, <i>sel_ref1</i> =1	7 LSB _{12Bit}	
16	Absolute, <i>sel_ref1</i> =0	26 LSB _{16Bit}	1.8
16	Ratiometric, <i>sel_ref1</i> =1	51 LSB _{16Bit}	
20	Absolute, <i>sel_ref1</i> =0	182 LSB _{20Bit}	3.5
20	Ratiometric, <i>sel_ref1</i> =1	270 LSB _{20Bit}	
24	Absolute, <i>sel_ref1</i> =0	1122 LSB _{24Bit}	10.4
24	Ratiometric, <i>sel_ref1</i> =1	1354 LSB _{24Bit}	

[a] Measurements including AZS, SM, AZT, TM with internal temperature measurement.

[b] Reference noise values normalized to the respective external sensor's ADC resolution, obtained with the following setup: 10kΩ sensor bridge, 25°C, Gain=28, V_{DD}=3.3V, *ioffsc*=00000 for *sel_ref1*=1, *ioffsc*=01111 for *sel_ref1*=0, *adc_en_shift*=0, *pga_en_shift*=0, *sensor_sup*=00, *cp_off*=0.

[c] The time from the end of the SSC-measurement command request AA_{HEX} to signalization for the end-of-conversion at the EOC pin with the ZSSC3240 in Command Mode; *INT_setup* bit field = 00_{BIN} in register 02_{HEX} (see Table 34).

6.5.2. Cyclic, Continuous, Repeated Measurements – Measurement Scheduler

In addition to single measurement requests, such as AA_{HEX} , or the *Oversample-x Measure* requests (AC_{HEX} to AF_{HEX} ; see Table 33), the ZSSC3240 can be configured for cyclic measurement sequences. The continuously running measurement sequence consists of individual measurement slots in which all or a selectable subset of measurements and checks can be scheduled and allocated including sensor measurement (S), auto-zero measurement for the sensor (AZS), temperature measurement (T), auto-zero measurement for temperature (AZT), and diagnostic checks (see section 6.3). If AZS is enabled ($AZMs_on = 1_{BIN}$ in register 04_{HEX} ; see Table 34 for details for registers), the sensor measurement (S) and auto-zero measurement for the sensor (AZS) must be scheduled to always occur together for correct signal processing; i.e., these settings are required: $slots_S = slots_AZS$ in register $1F_{HEX}$ and $startS_wfirstn = startAZS_wfirstn$ in register $1E_{HEX}$. If AZT is enabled ($AZMt_on = 1_{BIN}$ in register 04_{HEX}), the temperature measurement (T) and auto-zero measurement for temperature (AZT) must be scheduled to always occur together for correct signal processing; i.e., these settings are required: $slots_T = slots_AZT$ and $startT_wfirstn = startAZT_wfirstn$ (see registers $1E_{HEX}$ and $1F_{HEX}$). For applications where obtaining the fastest possible update rate is the highest priority, disabling the auto-zero measurements is recommended, i.e., $AZM*_on = 0_{BIN}$, for which slot scheduling is user programmable without constraints.

The automatically, continuously running measurement sequence is executed in Cyclic Mode, which is either entered as the default main operating mode after power-on or entered by means of the $START_CYC$ command, AB_{HEX} .

Figure 18 shows an example of the measurement sequence configurability. During the pauses in the sequence, the ZSSC3240 signals that it is not busy (i.e., the *Busy?* bit = 0_{BIN} in the general status byte; see Table 18). The available measurement results are updated at the end of each SSC calculation and output operation and are kept valid at the digital interface or DAC output until the next SSC calculation and output operation.

The configuration of the measurement scheduler is done in the NVM registers $1E_{HEX}$ to 20_{HEX} .

Measurement example with the following requirements:

- S every slot, start with first
- T every 7 slots, start with first
- Sensor Connection Check every 10 slots, no start with first slot
- No AZS ($AZMs_on = 0_{BIN}$)
- AZT every 7 slots, start with first

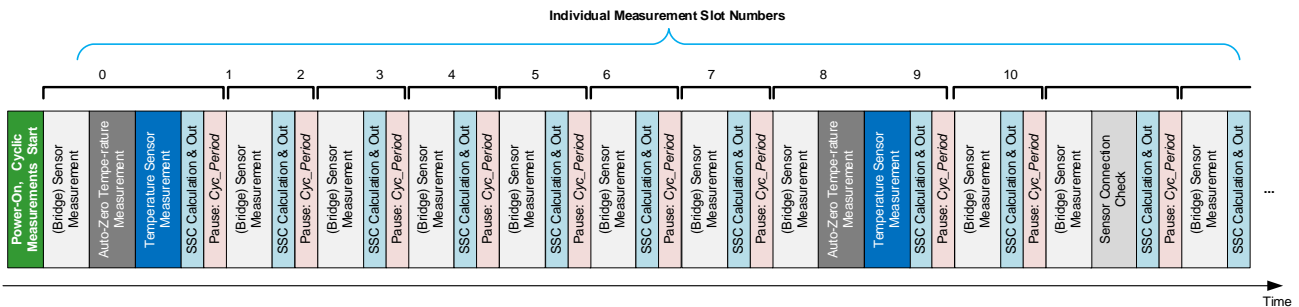

Figure 18. Example Configuration for the Measurement Scheduling and Cyclic Mode Operation

A slot denotes all measurements that are conducted and updated before the next SSC calculation. There can be pauses from one slot to the start of the next slot. The first slot has the slot number 0.

If the digital interface clock speed is too slow related to the SSC output update rate in Cyclic Mode, intermediate results might be lost.

6.5.3. Analog Outputs: Digital-to-Analog Converter (DAC)

The integrated, programmable digital-to-analog converter (DAC) generates an IC-internal analog signal that can be output at AOUT as an absolute voltage, V_{DD} -ratiometric voltage, or control signal for an externally connected current loop circuit. The analog output must be configured by $Aout_setup$ in the $SSF2$ register, 04_{HEX} .

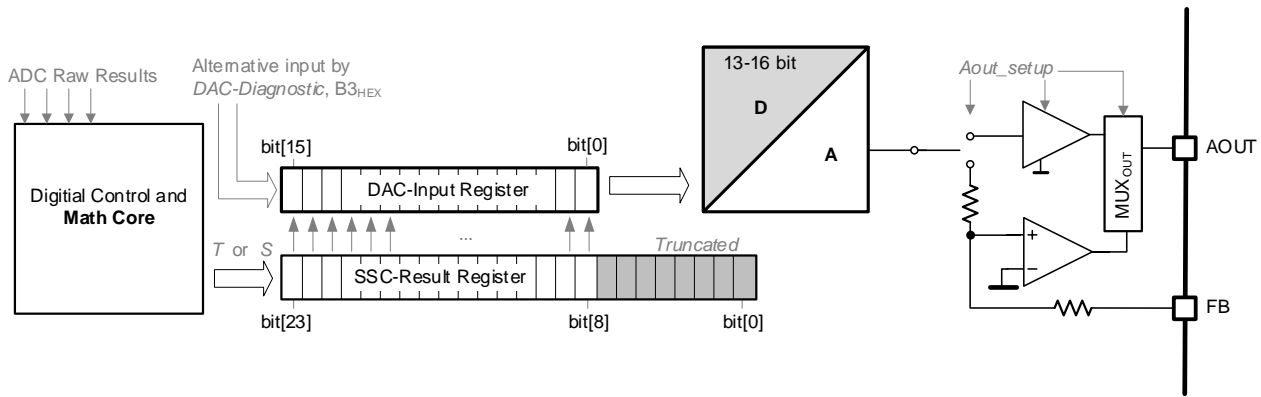

Figure 19. DAC and Analog Output Topology

The ZSSC3240 provides only analog outputs for signals that have been processed by the SSC calculation unit (see section 6.6.3), or that are directly transferred (via the digital command, *DAC-Diagnostic*, B3_{HEX}; see Table 33) as input to the DAC; e.g., for test or calibration purposes. The setup parameter *dacouttype*, bit[3] of the *SSF2* register, 04_{HEX} defines if either the SSC-corrected sensor value, S, or the SSC-corrected temperature value, T, is provided at AOUT; see Figure 19.

Table 28. DAC Configurations

dacres		Applied DAC Resolution	Maximum DAC Output Voltage $t_{DACsettle}$ Settling Time ^[a]
bit[1]	bit[0]		
0	0	13-Bit	150 μ s
0	1	14-Bit	160 μ s
1	0	15-Bit	180 μ s
1	1	16-Bit	200 μ s

[a] $t_{DACsettle}$ is the step-response time for the DAC and analog output stage (only); i.e., the time to reach 99% of the new analog output level after a DAC input change. For analog-output smart-sensor step-response time, the time for generating a new SSC-result as input to the DAC must also be considered.

For the suppression of spuriously emitted tones in the analog output signal, dithering within the DAC operation can be enabled/disabled via the *dither_off* bit in the *SSF2* register. If spurious tone emission is irrelevant in the application, dithering can be switched off in order to improve the analog output signal's noise level.

For analog diagnostic level signalization, enabled by the *diagouten* bit = 1_{BIN} in the *SSF2* register (see Table 16), the ZSSC3240 directly ties the analog output signal to 0% or 100% with the selected output stage, supported by digital pre-scaling to reserve approximately 1.5%-wide signal bands for diagnostic outputs. Strong recommendation: If the ZSSC3240 provides diagnostic levels, activate analog signalization of diagnostic levels before sensor calibration.

6.5.3.1. Voltage Outputs

The ZSSC3240 can provide one of three direct voltage outputs at the AOUT pin. The *Aout_setup* bit field in the *SSF2* register (bits [7:5]; see Table 34) is used to configure the ZSSC3240 and select the analog voltage output stage as defined in Table 29. It is also possible to set up the analog voltage output for 0V to 10V systems using additional external components.

Table 29. Direct Voltage Outputs

<i>Aout_setup</i>			Voltage Output (Range/Type) ^[a]	Comments
bit[2]	bit[1]	bit[0]		
0	0	0	–	Current loop; see section 6.5.3.3
0	0	1	0 to V_{DD} , ratiometric	Typical 0 to 5V; with $V_{DD} > 5V$, rail-to-rail output
0	1	0	0 to 1V, absolute	Any (valid) V_{DD}
0	1	1	0 to 5V, absolute	Requires $V_{DD} > 5.01V$
1	0	0	–	Not assigned

<i>Aout_setup</i>			Voltage Output (Range/Type) ^[a]	Comments
bit[2]	bit[1]	bit[0]		
1	0	1	0 to V _{DD} , ratiometric	Typical 0 to 5V; with V _{DD} > 5V, rail-to-rail output, OWI2 _{in} enabled as OWI input pin
1	1	0	0 to 1V, absolute	Any (valid) V _{DD} , OWI2 _{in} enabled as OWI input
1	1	1	0 to 5V, absolute	Requires V _{DD} > 5.01V, OWI2 _{in} enabled as OWI input

[a] The voltage outputs listed are directly supported, requiring minimal (for ratiometric output) or no (for absolute voltage output) additional external devices.

Table 30. Recommended Operating Conditions for Voltage Output

Symbol	Parameter	Typical Value	Unit	Comments
R _{Lout}	External, resistive load at AOUT	1	kΩ	For 1kHz to 5kHz output bandwidth, as RC low-pass filter configuration.
C _{Lout}	External, capacitive load at AOUT	10	nF	

6.5.3.2. Accuracy and Calibration of the DAC-Output

The 16-bit-DAC of ZSSC3240 is optimized from design prospective for high stability. Low drift over operational conditions can be achieved with minimal additional effort during the calibration phase, by compensating absolute errors/mismatches with mathematical adaptation of sensor calibration coefficients.

The functional, analog main-components of the ZSSC3240's DAC come with some residual level of IC-to-IC variation for DAC-characteristic's offset and gain. It is recommended to calibrate the DAC-characteristic and consider the linearity IC-to-IC-variation of the DAC at the IC's calibration, especially for applications with high requirements for absolute accuracy of the output voltage. For analog output configurations, the SSC coefficients can be derived such that the digital SSC-results and hence the DAC's digital input (*S* or *T*) is pre-shaped in order to compensate the residual DAC's (non-)linearity variation.

To avoid taking analog measurement values during the smart sensors' calibration procedure, the ZSSC3240 provides two high-precision DAC-calibration point measurement results in the NVM, *DAC10RM5V* and *DAC90RM5V* in the NVM registers 22_{HEX} and 23_{HEX}, see Table 34. Using these two high-precision DAC calibration points for the determination of the SSC-coefficients, the ZSSC3240 achieves a low residual, absolute DAC-output error of less than ±0.15% over the device specified temperature range, and over the DAC output swinging from 1% to 100% of the specified range. This approach can be also interpreted as mapping of the digital SSC-outputs (*S* or *T*) to an IC-to-IC-varying best fit straight line characteristic of the DAC. The residual DAC-error is typically higher in the signal range 0% to 1%, as the ZSSC3240's does not provide exactly 0V for zero-value digital DAC-inputs, *S* or *T*.

If more than two DAC-calibration points is considered, absolute accuracies below ±0.15% become possible, down to the analog output (AOUT) line's noise-and-distortion level.

6.5.3.3. Current Loop Output

The analog current loop is a typical output signal configuration, especially for industrial sensors. Using only two wires, the sensor is supplied with power and transmits its output signal to the processing unit. With *Aout_setup* = 000_{BIN} (bits [7:5] in the *SSF2* register; see Table 34), the ZSSC3240 will generate a SSC-corrected sensor-signal-proportional control signal at AOUT that allows generating a related loop current according the application in Figure 20.

Table 31. ZSSC3240 Current-Loop-Specific Properties

Symbol	Parameter	Typical Value	Unit	Comments
R ₁	Control feedback resistor, internal	120	kΩ	Combined with external R _{SENS} , defines the current-loop gain: R ₁ /R _{SENS} R ₁ -process-variation in the range of ±20%
R _{SENS}	External loop-sensing resistor	50	Ω	Using a low-TC resistor is recommended to minimize spurious temperature influence

Symbol	Parameter	Typical Value	Unit	Comments
β_{TLOOP}	Current gain of external-loop bipolar transistor, T_{LOOP}	100	Numeric	
BW_L	Transfer bandwidth of internal current loop op amp.	20	kHz	
$R_{SENSOR,MIN}$	External sensor element's minimum resistance	1.6	k Ω	With a ratiometric supply and resistances that are too low, the overall current consumption ($I_{SENSOR} + I_C$) at V_{DD} could exceed the 4mA low-limit for typical current loops (see Table 3 for I_{SENSOR} specifications, and see Table 4 for I_C specifications)
$I_{Loop,high}$	Loop-response current for logical-1; OWI over current-loop	14...18	mA	Effective current modulation when ZSSC3240 is OWI slave modulating the slave-to-master response via the loop current (controlled by AOUT/OWI1)
$I_{Loop,low}$	Loop-response current for logical-0; OWI over current-loop	4...6	mA	

Strong recommendation: Use the Zener diode between FB and VDD to protect the VDD line from positive over-voltage conditions and protect the FB input from negative over-voltages. The 100nF capacitor performs a low-pass-filter function for short/fast changes in the total current consumption for the sensor element plus the ZSSC3240 ($I_{SENS} + I_C$), such that current consumption changes do not lead to short-term fluctuations of AOUT and the loop current.

An equivalent effect of slight loop current fluctuations might be observable if a sensor-connection check is sometimes executed between the normal sensor measurements. Here, the connected sensor element, e.g., a resistive bridge, will be unsupplied briefly in order to determine the electrical connection properties; whereas an overall load change (sensor measurements → sensor-connection check → sensor-measurement) at VDD and hence in the current loop will be present. Therefore, diagnostic features should be carefully enabled and selected for current loop applications that have strong requirements for output signal quality under any circumstances.

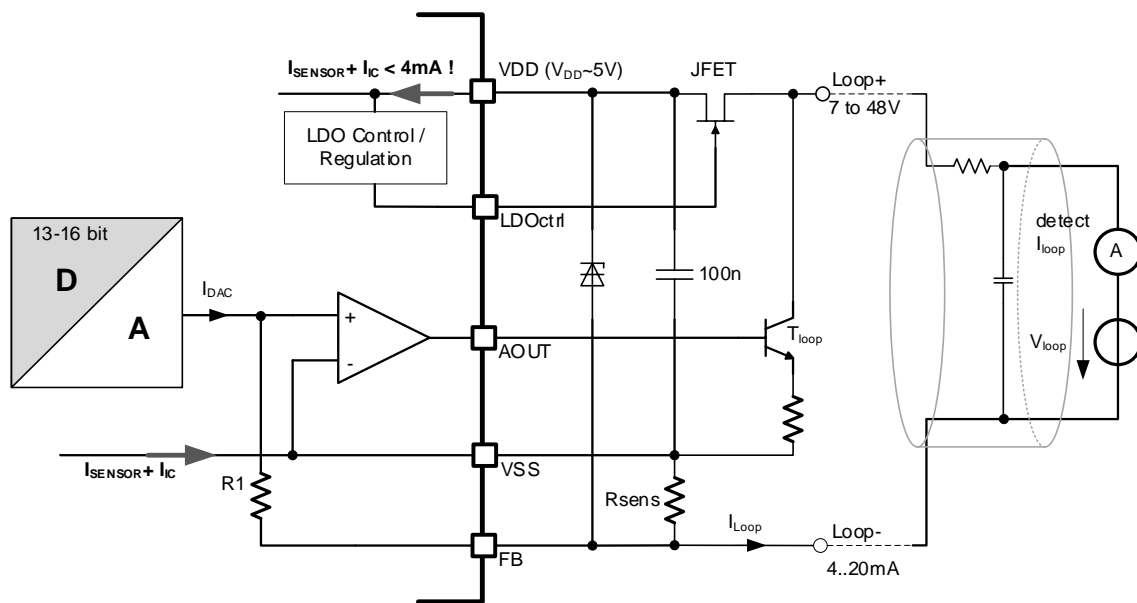

Figure 20. Current Loop Configuration

6.5.4. Output Interrupt Signaling

The EOC pin can be programmed to operate either as a simple “measurement busy” and end-of-conversion transducer or as a configurable interrupt transducer, which is configured using the $INT_setup[1:0]$ bits in NVM register 02_{HEX}, bits[8:7]. Further, one or two 24-bit quantized thresholds can be programmed via $TRSH1$ and $TRSH2$ (Interrupt Level Setup registers 18_{HEX}, 19_{HEX} and 1A_{HEX} in NVM; see Table 34). Depending on the INT_setup selection, the EOC pin provides a logic 1 or logic 0 (also dependent on the respective interface setup);

e.g., SPI with either logic 0 = V_{DD} or logic 0 = V_{SS} , etc.) according to the SSC-corrected measurement result. The respective thresholds must be programmed left-aligned in the memory with the threshold's MSB in the memory register's MSB, etc. The LSBs of the 24-bit threshold in memory are ignored depending on the number of bits of the ADC resolution as selected with *adc_bits* (see Table 10).

In this case, only the effective end-of-conversion is signaled (*INT_setup* = 00_{BIN}). The EOC signal is a pulse of approximately 5µs. The next command will be executed only after this EOC signaling period.

The interrupt functionality is only available for digital values from the SSC-calculation unit. The interrupt feature cannot monitor raw values. The encoding and data format of the interrupt thresholds is the same as for SSC-corrected measurement results (see Table 32).

Table 32. Data Format of Interrupt Thresholds (TRSH1 and TRSH2)

Bit-Number	23	22	21	20	...	2	1	0
Meaning, Weighting	2^0	2^{-1}	2^{-2}	2^{-3}	...	2^{-21}	2^{-22}	2^{-23}

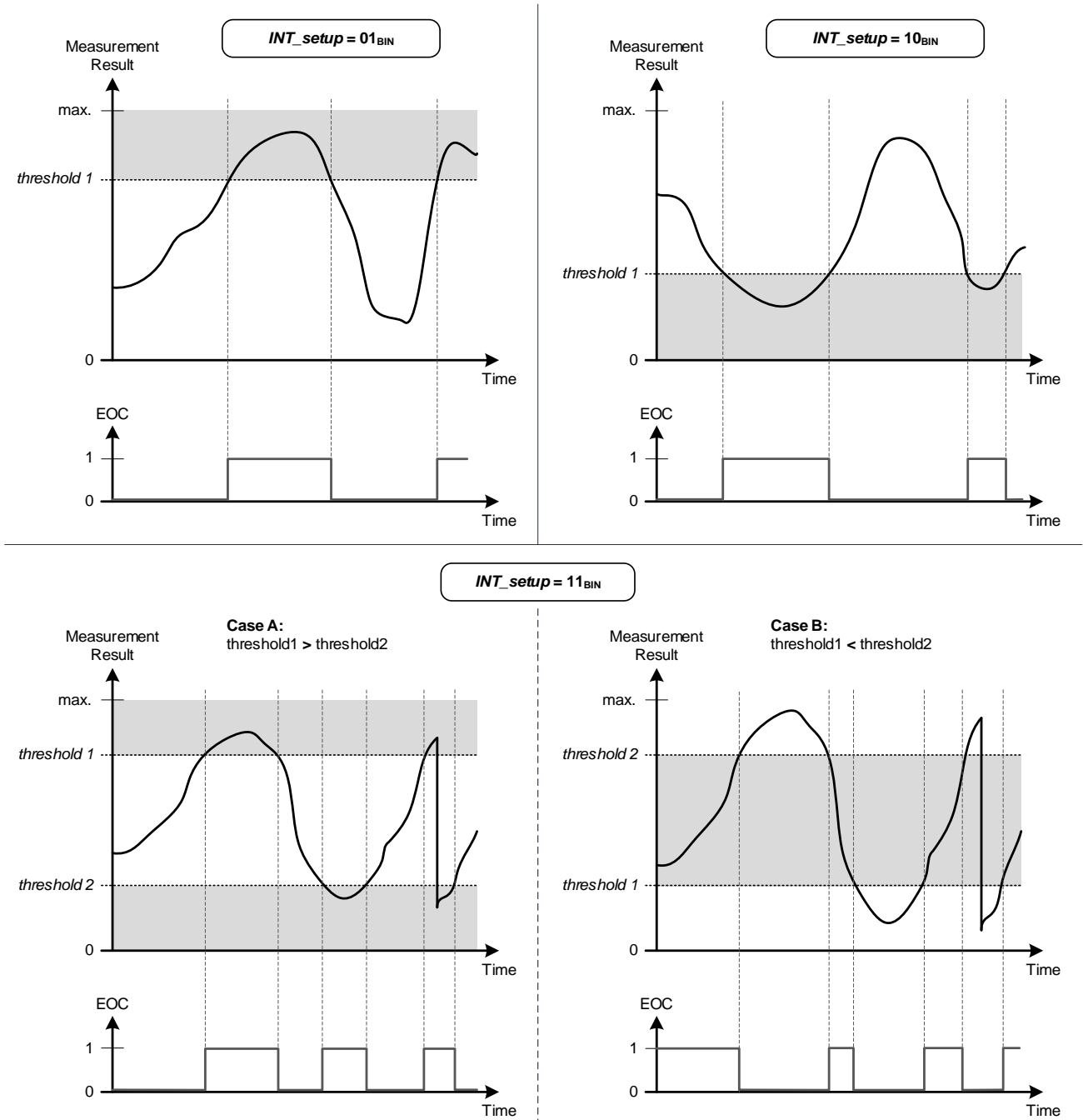

Figure 21. EOC and Interrupt Thresholds

6.6 System Setup and Control

The digital blocks of the ZSSC3240 are organized functionally as shown in Figure 22. In addition to the central blocks, which are the “Interfaces,” “Digital Main Core,” and “Memory (NVM)” blocks, there is also the Shadow Registers block, which in most cases, is a direct copy of the NVM registers. The shadow registers are loaded from NVM during the power-up sequence and allow acceleration of command processing and NVM-independent configuration adaptability; e.g., during adaptive sensor setup, evaluation, or smart sensor test. For the main function of the ZSSC3240 to conduct a sensor measurement and ADC-conversion, the setups (for main Sensor or Temperature) are loaded or activated from the corresponding Shadow Registers in order to set all IC-internal configuration switches for sensor supply, PGA gain, offset compensation, reference voltage sources, etc. After a settling time for the analog signals and levels, the A2D conversion takes place. This course of activities is (re-)done for each individual measurement, i.e. once for SM, AZS, TM, AZT, with setups for SM and AZS

according to the Shadow Registers for *SM_config1* and *SM_config2*, and for TM, AZT from registers *extTemp_config1* and *extTemp_config2*. If the internal temperature sensor was selected as signal source for TM, AZT, the setups are loaded from a Renesas-preprogrammed register different to *extTemp_config1* and *extTemp_config2*.

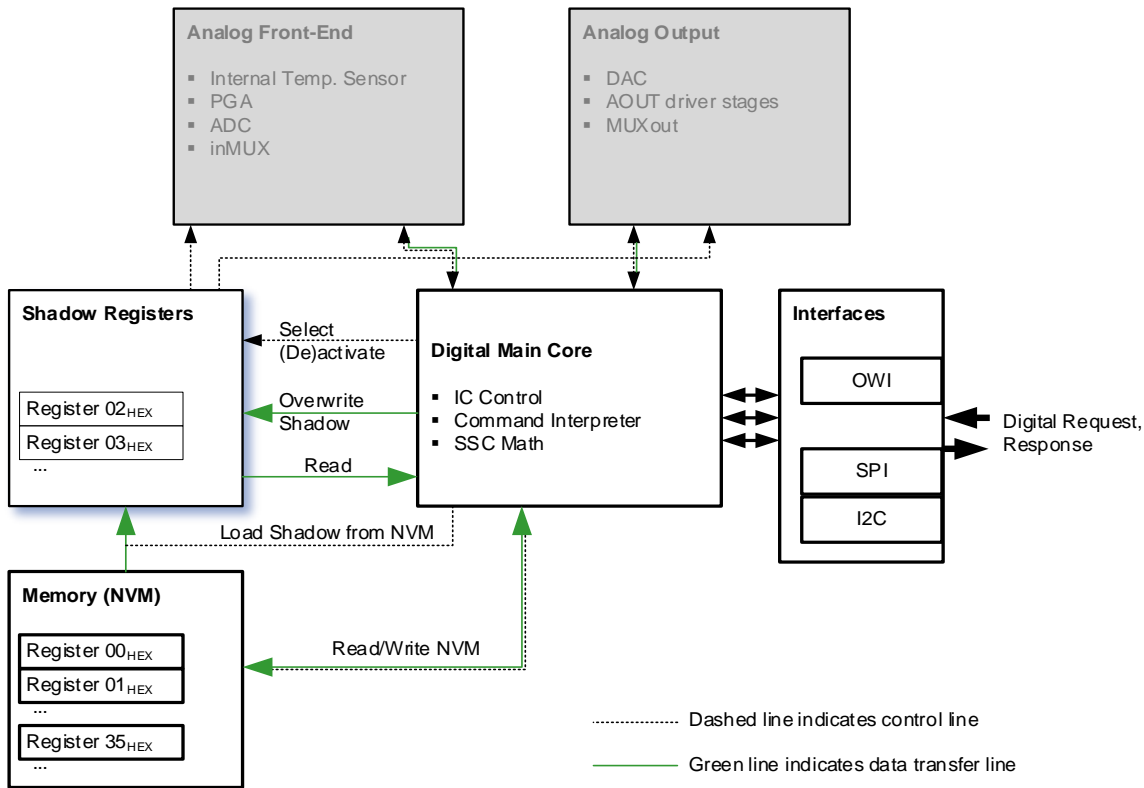

Figure 22. Digital IC Section Architecture

6.6.1. Digital Commands

The availability of commands depends on the active main operating mode: Command, Sleep, or Cyclic Mode.

Table 33. Command List

Note: See important table notes as the end of this table.

Command Code (Byte)	Return	Description	Available in Sleep Mode	Available in Command Mode	Available in Cyclic Mode
00 _{HEX} to 3F _{HEX}	16-bit data	Memory Read address 00 _{HEX} to 3F _{HEX}	Yes	Yes	No
40 _{HEX} to 75 _{HEX} followed by data (0000 _{HEX} to FFFF _{HEX})	–	Memory Write addresses 00 _{HEX} to 35 _{HEX} (NVM register address is command minus 40 _{HEX}); if the NVM is locked, write requests are not acknowledged or are ignored	Yes	Yes	No
90 _{HEX}	–	Calculate NVM Checksum and write it to the memory	Yes	Yes	No
A2 _{HEX}	24-bit raw data	Raw Sensor Measurement ^[a] – Configuration is loaded in the controlling shadow registers from the <i>SM_config1</i> and <i>SM_config2</i> registers in NVM <i>Note:</i> auto-zero sensor measurement is performed if set up in the <i>AZMs_on</i> bit in the <i>SSF2</i> register	Yes	Yes	No

Command Code (Byte)	Return	Description	Available in Sleep Mode	Available in Command Mode	Available in Cyclic Mode
A4 _{HEX}	24-bit raw data	Raw Temperature Measurement ^[a] – Configuration is loaded in the controlling shadow registers from the <i>extTemp_Config1/2</i> or <i>T_config1/2</i> registers in NVM as well as the <i>SSF1/2</i> registers Note: Auto-zero correction will be performed if set up via the <i>AZMt_on</i> bit in the <i>SSF2</i> register Note: If a raw data measurement with an external setup (different from the NVM content) will be performed, then pre-load the measurement configuration via the <i>Overwrite SSF1/2 Register</i> and <i>Overwrite T_config1/2 Shadow Register</i> commands. Note: The internal or external temperature measurement will be performed if set up via the <i>temp_source</i> bit field in the <i>SSF1</i> register	Yes	Yes	No
A8 _{HEX}	–	START_SLEEP – Exit Command Mode or Cyclic Mode and transition to Sleep Mode Note: The response to <i>Start_Sleep</i> is only the status byte	No	Yes	Yes
A9 _{HEX}	–	START_CM – Exit Sleep Mode or Cyclic Mode and transition to Command Mode	Yes	No	Yes
AA _{HEX}	24-bit SSC-corrected sensor data and 24-bit SSC-corrected temperature data	Measure – Trigger a full measurement (auto-zero-sensor, sensor, auto-zero-temperature, temperature) and perform SSC correction Note: Auto-zero correction is performed with this command if set up in the <i>AZMs_on</i> and <i>AZMt_on</i> bits in the <i>SSF2</i> register	Yes	Yes	No
AB _{HEX}	–	START_CYC – Enter the Cyclic Mode: continuous measurement cycles, SSC corrections, and automatic, continuous digital and/or analog output updates	Yes	Yes	No
AC _{HEX}	24-bit SSC-corrected sensor data and 24-bit SSC-corrected temperature data	Oversample-2 Measure ^[b] – Mean value generation; 2 full measurements (triggered similar to AA _{HEX} , not cyclic) are performed and the resulting mean value is provided as output Note: Auto-zero correction is performed with this command if set up in the <i>AZMs_on</i> and <i>AZMt_on</i> bits in the <i>SSF2</i> register	Yes	Yes	No
AD _{HEX}		Oversample-4 Measure ^[b] – Mean value generation; 4 full measurements (triggered similar to AA _{HEX} , not cyclic) are performed and the resulting mean value is provided as output Note: Auto-zero correction is performed with this command if set up in the <i>AZMs_on</i> and <i>AZMt_on</i> bits in the <i>SSF2</i> register	Yes	Yes	No
AE _{HEX}		Oversample-8 Measure ^[b] – Mean value generation; 8 full measurements (triggered similar to AA _{HEX} , not cyclic) are performed and the resulting mean value is provided as output Note: Auto-zero correction is performed with this command if set up in the <i>AZMs_on</i> and <i>AZMt_on</i> bits in the <i>SSF2</i> register	Yes	Yes	No
AF _{HEX}		Oversample-16 Measure ^[b] – Mean value generation; 16 full measurements (triggered similar to AA _{HEX} , not cyclic) are performed and the resulting mean value is provided as output Note: Auto-zero correction is performed with this command if set up in the <i>AZMs_on</i> and <i>AZMt_on</i> bits in the <i>SSF2</i> register	Yes	Yes	No
B0 _{HEX}	16-bit diagnostic result data	CHECK_DIAG – The ZSSC3240 responds with the detailed fault-result status in the <i>diagnosticreg</i> register	Yes	Yes	No

Command Code (Byte)	Return	Description	Available in Sleep Mode	Available in Command Mode	Available in Cyclic Mode
B1 _{HEX}	–	RESET_DIAG – Resets the contents of <i>diagnosticreg</i> to 00 _{HEX}	Yes	Yes	No
B2 _{HEX}	–	Update_DIAG – Causes a complete diagnostics check cycle including memory CRC calculation, etc., and results in a reset and update of <i>diagnosticreg</i> Note: If a measurement cycle is running concurrently, the diagnostic update happens after completion of the measurement cycle and SSC calculations (and might delay the next cyclic measurement cycle)	Yes	Yes	No
B3 _{HEX} followed by data (0000 _{HEX} to FFFF _{HEX})	–	DAC Diagnostic – Set the DAC output register with the data in the command and enable/output the respective analog signal through AOUT (according to the <i>AOUT_setup</i>) Note: The DAC output can be switched off by the RESQ pin, POR, or a change in the main operating mode	No	Yes	No
B4 _{HEX} followed by 00XX _{HEX}	24-bit raw data	Self-Diagnostic Measure – The ADC performs a raw measurement with the setup from the <i>SM_config</i> registers, and the PGA input is disconnected from the external sensor and internally shorted (INN = INP = AGND). The ZSSC3240-internal setup, which is configured according to the <i>ioffsc</i> bit field in the <i>SM_config2</i> register, is changed to XX _{HEX} (transmitted with the command). The respective pseudo-offset signal becomes the input test signal to the PGA-ADC-path. The original <i>ioffsc</i> and <i>SM_config2</i> contents are restored after the self-diagnostic measurement completion. Note: alternatively, also a changed setup (PGA, ADC) could be used by applying <i>Overwrite</i> commands prior to the self-diagnostic measurement.	No	Yes	No
D1 _{HEX} followed by XXXX _{HEX}	–	Set Post-Calibration Offset – Set recent SSC-output to expected value XXXX _{HEX} in command by means of offset adjustment with coefficient <i>SENS_shift</i>	Yes	Yes	No
D2 _{HEX}	–	Startup OWI – Initialization command to enter OWI interface operation; only valid for OWI (see section 6.4.3)	Yes	Yes	Yes
D6 _{HEX} followed by data (0000 _{HEX} to FFFF _{HEX})	–	Overwrite <i>SM_config1</i> shadow register – Content (originally from NVM register 14 _{HEX}) in the digital shadow register for <i>SM_config1</i> is directly overwritten with the command data ^[c]	No	Yes	No
D7 _{HEX} followed by data (0000 _{HEX} to FFFF _{HEX})	–	Overwrite <i>SM_config2</i> shadow register – Content (originally from NVM register 15 _{HEX}) in the digital shadow register for <i>SM_config2</i> is directly overwritten with the command data ^[c]	No	Yes	No
D8 _{HEX} followed by data (0000 _{HEX} to FFFF _{HEX})	–	Overwrite <i>T_config1</i> shadow register – Content (originally from NVM register 16 _{HEX} or 3C _{HEX}) in the digital shadow register for the temperature measurement is directly overwritten with the command data ^[c]	No	Yes	No
D9 _{HEX} followed by data (0000 _{HEX} to FFFF _{HEX})	–	Overwrite <i>T_config2</i> shadow register – Content (originally from NVM register 17 _{HEX} or 3D _{HEX}) in the digital shadow register for the temperature measurement is directly overwritten with the command data ^[c]	No	Yes	No

Command Code (Byte)	Return	Description	Available in Sleep Mode	Available in Command Mode	Available in Cyclic Mode
DA _{HEX} followed by data (0000 _{HEX} to FFFF _{HEX})	-	Overwrite SSF1 shadow register – Content (originally from NVM register 03 _{HEX}) in the digital shadow register for <i>SSF1</i> is directly overwritten with the command data ^[c] Note: transferred bits[1:0] and bits[15:13] are ignored; i.e., are not overwritten in the shadow register	No	Yes	No
DB _{HEX} followed by data (0000 _{HEX} to FFFF _{HEX})	-	Overwrite SSF2 shadow register – Content (originally from NVM register 04 _{HEX}) the digital shadow register for <i>SSF2</i> is directly overwritten with the command data ^[c]	No	Yes	No
FX _{HEX}	Status followed by last 24-bit data	NOP – Output of read results; only valid for SPI (see section 6.4.1)	Yes	Yes	Yes

- [a] These commands can be used to conduct a measurement without an SSC correction; e.g., during the smart sensor calibration procedure. No digital correction is performed on the measurement result. The setup and configuration for the raw measurement is the content in the shadow registers that can be pre-loaded (automatically loaded during power-on) from the NVM or by means of the *Overwrite* commands, D6_{HEX} to DB_{HEX}.
- [b] Use *Oversample* measurements to obtain noise-minimized measurement results in Sleep or Command Mode. With higher oversampling factors, the command execution time increases proportionally.
- [c] *Overwrite* commands can be used to optimize evaluation and test routine execution time for analog front-end setup or to configure self-diagnostic measurement setups without needing to change the ZSSC3240's NVM content. The content and effects from *Overwrite* commands are cleared and reset with the ZSSC3240 reset via the RESQ pin or POR.

6.6.2. Nonvolatile Memory (NVM)

In the ZSSC3240, the memory is organized in 16-bit wide registers and can be programmed multiple times (approximately 10000). There are 54 × 16-bit registers available for customer use. Each register can be re-programmed.

Basically, there are two NVM content sectors:

- **Customer Use:** Accessible via regular write operations: 40_{HEX} to 75_{HEX}. This sector contains the customer ID, interface setup data, measurement setup information, calibration coefficients, analog output configuration, etc.
- **Renesas Use:** Only accessible for write operations by Renesas. This sector (36_{HEX} to 3F_{HEX}) contains specific trim information and is programmed during manufacturing test by Renesas, e.g. setups for the internal temperature sensor are stored there.

The whole NVM can be locked by programming *lock* = 1_{BIN} in the *SSF1* register, NVM address 03_{HEX}, bit[14]. No change of the NVM content is possible once the NVM lock has been activated.

Recommendations when using the NVM lock:

- Write all required setups, configurations, and SSC coefficients to the NVM first.
- Then write the *SSF1* register content with the *lock* bit set.
- Then trigger the generation and writing of the CRC via the *Calculate NVM Checksum* command, 90_{HEX}.

The NVM lock will be effective after a ZSSC3240 reset with POR or RESQ.

NVM Address	Word/Bit Range	Default Setting	Description	Notes/Explanations
	8	0 _{BIN}	diagouten	Enable diagnostic level output mode: The lower and upper analog output range levels are reserved for diagnostic signaling according to Table 16. The ZSSC3240 performs an automatic DAC-output scaling (if already digitally calibrated) to reserve the lower and upper 1.56% band or absolute voltage levels: 0 = No analog signalization 1 = Analog diagnostic signaling is enabled
	9	0 _{BIN}	disable_ldoctrl	Switch off the internal output regulator circuit running the LDOctrl pin if no external supply transistor (such as JFET) is used; this reduces current consumption, etc. 0 = LDOctrl output is switched/kept on 1 = LDOctrl output switched off Note: If enabled (= 0), then the charge-pump can be off (the <i>cp_off</i> bit = 1 in register 03 _{HEX})
	11:10	10 _{BIN}	VDD_ldoctrl_target	Set point for regulated V _{DD} using external supply transistor JFET or depletion MOSFET: 00 = V _{DD} = 4.8V 01 = V _{DD} = 5.0V 10 = V _{DD} = 5.2V 11 = V _{DD} = 5.4V
	12	0 _{BIN}	AZMs_on	Enable/disable for auto-zero measurement for (bridge) sensor measurement: 0 = No auto-zero measurements for sensor signal 1 = Auto-zero measurement of sensor bridge is performed and processed Note: This setup is ignored for raw data measurements with setup via the interface, i.e. command A2 _{HEX}
	13	0 _{BIN}	AZMt_on	Enable/disable for auto-zero measurement for temperature measurement: 0 = No auto-zero measurements for temperature signal 1 = Auto-zero measurement for temperature signal performed and processed
	15:14	00 _{BIN}	oversamp_cyc	Selection for applied digital oversampling in Cyclic Mode operation: 00 = No oversampling 01 = Oversample-4: Results of 4 SSC cycles per last <i>meas_scheduler</i> sequence 10 = Oversample-8: Results of 8 SSC cycles per last <i>meas_scheduler</i> sequence 11 = Oversample-16: Results of 16 SSC cycles per last <i>meas_scheduler</i> sequence Note: This setup is ignored for any measurement in Command and Sleep Mode
Signal Conditioning Parameters				
05 _{HEX}	15:0	0000 _{HEX}	Offset_S[15:0]	Bits [15:0] of the 24-bit-wide sensor offset correction coefficient <i>Offset_S</i> . The MSBs including sign are <i>Offset_S</i> [23:16], which is [15:8] in register 0F _{HEX} .
06 _{HEX}	15:0	0000 _{HEX}	Gain_S[15:0]	Bits [15:0] of the 24-bit-wide value of the sensor gain coefficient <i>Gain_S</i> . The MSBs including sign are <i>Gain_S</i> [23:16], which is [7:0] in register 0F _{HEX} .
07 _{HEX}	15:0	0000 _{HEX}	Tcg[15:0]	Bits [15:0] of the 24-bit-wide coefficient <i>Tcg</i> for the temperature correction of the sensor gain. The MSBs including sign are <i>Tcg</i> [23:16], which is bits [15:8] in register 10 _{HEX} .
08 _{HEX}	15:0	0000 _{HEX}	Tco[15:0]	Bits [15:0] of the 24-bit-wide coefficient <i>Tco</i> for temperature correction of the sensor offset. The MSBs with sign are <i>Tco</i> [23:16], which is bits [7:0] in register 10 _{HEX} .
09 _{HEX}	15:0	0000 _{HEX}	SOT_tco[15:0]	Bits [15:0] of the 24-bit-wide 2 nd order term <i>SOT_tco</i> applied to <i>Tco</i> . The MSBs of this term including sign are <i>SOT_tco</i> [23:16], which is bits [15:8] in register 11 _{HEX} .

NVM Address	Word/Bit Range	Default Setting	Description	Notes/Explanations
0A _{HEX}	15:0	0000 _{HEX}	SOT_tcg[15:0]	Bits [15:0] of the 24-bit-wide 2 nd order term <i>SOT_tcg</i> applied to <i>Tcg</i> . The MSBs of this term including sign are <i>SOT_tcg</i> [23:16], which is bits[7:0] in register 11 _{HEX} .
0B _{HEX}	15:0	0000 _{HEX}	SOT_sens[15:0]	Bits [15:0] of the 24-bit-wide 2 nd order term <i>SOT_sens</i> applied to the sensor readout. The MSBs of this term including sign are <i>SOT_sens</i> [23:16], which is bits[15:8] in register 12 _{HEX} .
0C _{HEX}	15:0	0000 _{HEX}	Offset_T[15:0]	Bits [15:0] of the 24-bit-wide temperature offset correction coefficient <i>Offset_T</i> . The MSBs of this coefficient including sign are <i>Offset_T</i> [23:16], which is bits[7:0] in register 12 _{HEX} .
0D _{HEX}	15:0	0000 _{HEX}	Gain_T[15:0]	Bits [15:0] of the 24-bit-wide absolute value of the temperature gain coefficient <i>Gain_T</i> . The MSBs including sign are <i>Gain_T</i> [23:16], which is bits[15:8] in register 13 _{HEX} .
0E _{HEX}	15:0	0000 _{HEX}	SOT_T[15:0]	Bits [15:0] of the 24-bit-wide 2 nd -order term <i>SOT_T</i> applied to the temperature reading. The MSBs including sign are <i>SOT_T</i> [23:16], which is bit[7:0] in register 13 _{HEX} .
0F _{HEX}	7:0	20 _{HEX}	Gain_S[23:16]	Bits [23:16] including sign for the 24-bit-wide sensor gain correction coefficient <i>Gain_S</i> . The LSBs of this coefficient are <i>Gain_S</i> [15:0] in register 06 _{HEX} .
	15:8	00 _{HEX}	Offset_S[23:16]	Bits [23:16] including sign for the 24-bit-wide sensor offset correction coefficient <i>Offset_S</i> . The LSBs are <i>Offset_S</i> [15:0] in register 05 _{HEX} .
10 _{HEX}	7:0	00 _{HEX}	Tco[23:16]	Bits [23:16] including sign for the 24-bit-wide coefficient <i>Tco</i> for temperature correction for the sensor offset. The LSBs are <i>Tco</i> [15:0] in register 08 _{HEX} .
	15:8	00 _{HEX}	Tcg[23:16]	Bits [23:16] including sign for the 24-bit-wide coefficient <i>Tcg</i> for the temperature correction of the sensor gain. The LSBs are <i>Tcg</i> [15:0] in register 07 _{HEX} .
11 _{HEX}	7:0	00 _{HEX}	SOT_tcg[23:16]	Bits [23:16] including sign for the 24-bit-wide 2 nd order term <i>SOT_tcg</i> applied to <i>Tcg</i> . The LSBs are <i>SOT_tcg</i> [15:0] in register 0A _{HEX} .
	15:8	00 _{HEX}	SOT_tco[23:16]	Bits [23:16] including sign for the 24-bit-wide 2 nd order term <i>SOT_tco</i> applied to <i>Tco</i> . The LSBs are <i>SOT_tco</i> [15:0] in register 09 _{HEX} .
12 _{HEX}	7:0	00 _{HEX}	Offset_T[23:16]	Bits [23:16] including sign for the 24-bit-wide temperature offset correction coefficient <i>Offset_T</i> . The LSBs are <i>Offset_T</i> [15:0] in register 0C _{HEX} .
	15:8	00 _{HEX}	SOT_sens[23:16]	Bits [23:16] including sign for the 24-bit-wide 2 nd order term <i>SOT_sens</i> applied to the sensor readout. The LSBs are <i>SOT_sens</i> [15:0] in register 0B _{HEX} .
13 _{HEX}	7:0	00 _{HEX}	SOT_T[23:16]	Bits [23:16] including sign for the 24-bit-wide 2 nd -order term <i>SOT_T</i> applied to the temperature reading. The LSBs are <i>SOT_T</i> [15:0] in register 0E _{HEX} .
	15:8	20 _{HEX}	Gain_T[23:16]	Bits [23:16] including sign for the 24-bit-wide absolute value of the temperature gain coefficient <i>Gain_T</i> . The LSBs are <i>Gain_T</i> [15:0] in register 0D _{HEX} .
Measurement Configuration Register 1 (SM_config1)				
14 _{HEX}	3:0	0000 _{BIN}	Gain_stage1	Gain setting for the 1 st PGA stage with <i>Gain_stage1</i> [3:0]: Parameters are valid for Gain _{PGA} ≤ 192: 0000 = 1.2 0110 = 30 0001 = 2 0111 = 40 0010 = 4 1000 = 60 0011 = 6 1001 = 80 0100 = 12 1010 = 120 0101 = 20 Parameters are limited for Gain _{PGA} > 192: 1011 = 150 1100 = 200 1101 = 240 1110 = 300 1111 = Not assigned
	6:4	000 _{BIN}	Gain_stage2	Gain setting for the 2 nd PGA stage with <i>Gain_stage2</i> [1:0]: 000 = 1.1 100 = 1.5 001 = 1.2 101 = 1.6 010 = 1.3 110 = 1.7 011 = 1.4 111 = 1.8

NVM Address	Word/Bit Range	Default Setting	Description	Notes/Explanations
External Temperature Measurement Configuration Register 1 (<i>extTemp_config1</i>)				
16 _{HEX}	3:0	0000 _{BIN}	Gain_stage1	Gain setting for the 1 st PGA stage with <i>Gain_stage1</i> [3:0] for external temperature measurements: Parameters are valid for Gain _{PGA} ≤ 192: 0000 = 1.2 0110 = 30 0001 = 2 0111 = 40 0010 = 4 1000 = 60 0011 = 6 1001 = 80 0100 = 12 1010 = 120 0101 = 20 Parameters are limited for Gain _{PGA} > 192: 1011 = 150 1100 = 200 1101 = 240 1110 = 300 1111 = Not assigned
	6:4	000 _{BIN}	Gain_stage2	Gain setting for the 2 nd PGA stage with <i>Gain_stage2</i> [1:0] for external temperature measurements: 000 = 1.1 100 = 1.5 001 = 1.2 101 = 1.6 010 = 1.3 110 = 1.7 011 = 1.4 111 = 1.8
	7	0 _{BIN}	Gain_polarity	Set up the polarity of the temperature sensor gain (invert input) with: 0 = Positive (no polarity change) 1 = Negative (180° polarity change)
	11:8	0100 _{BIN}	adc_bits	Resolution, i.e. absolute number of bits for the ADC for external temperature measurements with <i>adc_bits</i> [3:0]: 0000 = 12 0111 = 19 0001 = 13 1000 = 20 0010 = 14 1001 = 21 0011 = 15 1010 = 22 0100 = 16 (default) 1011 = 23 0101 = 17 1100 = 24 0110 = 18 1101 to 1111 = Not assigned
	14:12	000 _{BIN}	adc_offset	Differential signal's offset shift in ADC including gain x2 for external temperature measurements; compensation of x% signal offset: 000 = 0%, no offset compensation 001 = 6.25% offset 010 = 12.50% offset 011 = 18.75% offset 100 = 25.00% offset 101 = 31.25% offset 110 = 37.50% offset 111 = 44.00% offset
	15	0 _{BIN}	sel_ref2	Reference source for external temperature sensing and conversion: 0 = Absolute (internal) bandgap is reference 1 = Ratiometric reference; recommended for ratiometrically supplied sensors

NVM Address	Word/Bit Range	Default Setting	Description	Notes/Explanations
External Temperature Measurement Configuration Register 2 (<i>extTemp_config2</i>)				
17 _{HEX}	4:0	0 0000 _{BIN}	ioffsc	Absolute voltage input shift for input signals for external temperature measurements to the PG, e.g. INP-INN The input signal is shifted by the following voltages: 00000 = 0mV, no shift 00001 = -1mV 00010 = -2mV 00011 = -3mV ... 01110 = -14mV 01111 = -15mV 10000 = 0mV, no shift 10001 = +1mV 10010 = +2mV ... 11110 = +14mV 11111 = +15mV
	7:5	000 _{BIN}	Tbiasout	Current Mode sensor bias selection for external temperature measurements; nominal sensor supply current (if <i>temp_source</i> ∈ {001 _{BIN} , 010 _{BIN} , 011 _{BIN} , 100 _{BIN} }): 000 = 5μA 001 = 10μA 010 = 20μA 011 = 39μA 100 = 79μA 101 = 157μA 110 = 196μA 111 = 494μA
	8	0 _{BIN}	adc_en_shift	General disable/enable of the ADC feature for external temperature measurements to apply the extra gain x2 and signal offset compensation <i>adc_offset</i> in register 16 _{HEX} : 0 = Gain: x2 and signal offset compensation off 1 = Gain: x2 and signal offset compensation on
	9	0 _{BIN}	pga_en_shift	Automatic common mode adjust feature, which allows automatically, optimally adapting the sensor-input common mode to AGND at the PGA output for external temperature measurements. ^[d] 0 = Automatic common mode adjustment off 1 = Automatic common mode adjustment on
	15:10	00 0000 _{BIN}	–	Not assigned
Interrupt Level Setup and Post-Calibration (Digital) Offset Calibration				
18 _{HEX}	15:0	0000 _{HEX}	TRSH1[15:0]	Bits [15:0] of the 24-bit-wide interrupt threshold1, <i>TRSH1</i> . (The MSBs for this threshold are TRSH1[23:16], which is bits [7:0] of register 1A _{HEX} .)
19 _{HEX}	15:0	0000 _{HEX}	TRSH2[15:0]	Bits [15:0] of the 24-bit-wide interrupt threshold2, <i>TRSH2</i> . (The MSBs for this threshold are TRSH2[23:16], which is bits[15:8] of register 1A _{HEX} .)
1A _{HEX}	7:0	00 _{HEX}	TRSH1[23:16]	Bits [23:16] of the 24-bit-wide interrupt threshold1, <i>TRSH1</i> . (The LSBs for this threshold are TRSH1[15:0], which is bits[15:0] of register 18 _{HEX} .)
	15:8	00 _{HEX}	TRSH2[23:16]	Bits [23:16] of the 24-bit-wide interrupt threshold2, <i>TRSH2</i> . (The LSBs for this threshold are TRSH2[15:0], which is bits[15:0] of register 19 _{HEX} .)
1B _{HEX}	15:0	0000 _{HEX}	SENS_Shift[15:0]	Bits [15:0] of the post-calibration sensor offset shift coefficient <i>SENS_Shift</i> . (The MSBs of <i>SENS_Shift</i> are bits [15:8] of register 1D _{HEX} .)
1C _{HEX}	15:0	0000 _{HEX}	T_Shift[15:0]	Bits [15:0] of the post-calibration temperature offset shift coefficient <i>T_Shift</i> . (The MSBs of <i>T_Shift</i> are bits [7:0] of register 1D _{HEX} .)
1D _{HEX}	7:0	00 _{HEX}	T_Shift[23:16]	Bits [23:16] of the post-calibration temperature offset shift coefficient <i>T_Shift</i> . (The LSBs of <i>T_Shift</i> are in register 1C _{HEX} .)

NVM Address	Word/Bit Range	Default Setting	Description	Notes/Explanations
	15:8	00 _{HEX}	SENS_Shift[23:16]	Bits [23:16] of the post-calibration sensor offset shift coefficient <i>SENS_Shift</i> . (The LSBs of <i>SENS_Shift</i> are in register 1B _{HEX} .)
Measurement Scheduler (Cyclic Operation Sequence)				
1E _{HEX}	0	0 _{BIN}	cycwsn	Cyclic measurement operation is performed with/including the sensor measurement: 0 = Sensor measurement is performed 1 = Sensor measurement is not performed Note: Whether AZS is to be performed in the cyclic measurement sequence is set up with <i>AZMs_on</i> (see register 04 _{HEX})
	1	0 _{BIN}	cycwtn	Cyclic measurement operation is performed with the temperature measurement: 0 = Temperature measurement is performed 1 = Temperature measurement is not performed Note: whether AZT is to be performed in the cyclic measurement sequence is set up with <i>AZMt_on</i> (see register 04 _{HEX})
	2	0 _{BIN}	-	Not assigned
	3	0 _{BIN}	cycwscn	Cyclic measurement operation is performed with/including the sensor-connection check: 0 = Sensor connection check is performed 1 = Sensor connection check is not performed
1E _{HEX} (continued)	The bits [9:4] in the 1E _{HEX} register define whether the cycle measurement sequence performs the respective measurement type in the first slot or only after respective <i>slots_X</i> have been completed for the first time. Note: The SSC and analog output will only become valid after the sensor, temperature, and related auto-zero measurements have already been conducted for the first time. The first output signals maybe invalid until this condition is reached.			
	4	0 _{BIN}	startS_wfirstn	0 = Perform the sensor measurement in the first slot 1 = Do not perform the sensor measurement in the first slot
	5	0 _{BIN}	startAZS_wfirstn	0 = Perform the auto-zero sensor measurement in the first slot 1 = Do not perform the auto-zero sensor measurement in the first slot Note: The <i>startAZS_wfirstn</i> bit is ignored for the cyclic operation if the <i>AZMs_on</i> = 0 = "off."
	6	0 _{BIN}	startT_wfirstn	0 = Perform the temperature measurement in the first slot 1 = Do not perform the temperature measurement in the first slot
	7	0 _{BIN}	startAZT_wfirstn	0 = Perform the auto-zero temperature measurement in the first slot 1 = Do not perform the auto-zero temperature measurement in the first slot Note: The <i>startAZT_wfirstn</i> bit is ignored for the cyclic operation if the <i>AZMt_on</i> = 0 = "off."
	8	0 _{BIN}	-	Not assigned
	9	0 _{BIN}	startSC_wfirstn	Diagnostics: sensor connection checks: 0 = Perform sensor connection checks in the first slot 1 = Do not perform sensor connection checks in the first slot
	15:10	00 0000 _{BIN}	slots_T	Defines the number of pause slots between two subsequent temperature measurements: 0 = No pause, measure temperature at each slot 1 _{DEC} to 63 _{DEC} = Pause slots after the slot with the temperature measurement

NVM Address	Word/Bit Range	Default Setting	Description	Notes/Explanations
1F _{HEX}	5:0	00 0000 _{BIN}	slots_AZT	Defines the number of pause slots between two subsequent auto-zero temperature (AZT) measurements: 0 = No pause, measure AZT at each slot 1 to 63 _{DEC} = Number of pause slots after the slot with the AZT measurement Note: If <i>AZMt_on</i> = 0, no auto-zero temperature measurement will be performed.
	9:6	0000 _{BIN}	slots_S	Defines the number of pause slots between two subsequent sensor/bridge measurements: 0 = No pause, measure sensor at each slot 1 _{DEC} to 5 _{DEC} = Number of pause slots after the slot with the sensor measurement
	15:10	00 0000 _{BIN}	slots_AZS	Defines the number of pause slots between two subsequent auto-zero-sensor (AZS) measurements: 0 = No pause, measure AZS at each slot 1 _{DEC} to 63 _{DEC} = Number of pause-slots after slot with sensor measurement Note: If <i>AZMs_on</i> = 0, no auto-zero-sensor measurement at all will be performed.
20 _{HEX}	5:0	00 0000 _{BIN}	–	Not assigned.
	15:6	00 0000 0000 _{BIN}	slots_SC	Defines the number of pause slots between two subsequent sensor connection check runs: 0 = No pause, always check sensor connection 1 _{DEC} to 1023 _{DEC} = Number of pause-slots after slot with Sensor-Connection check
Selection of (Sensor) Connection Checks to be Conducted				
21 _{HEX}	The first 10 bits of register 21 _{HEX} are the <i>select_checks[9:0]</i> bit field:			
	0	0 _{BIN}	inp_check	Loss of sensor positive connection, INP 0 = Check is not performed; result is not signaled 1 = Check is performed; result is signaled
	1	0 _{BIN}	inn_check	Loss of bridge/sensor negative connection, INN 0 = Check is not performed; result is not signaled 1 = Check is performed; result is signaled
	2	0 _{BIN}	inp_range_check	Signal at pin INP out of range (leaking/short to VSS or VDDB) 0 = Check is not performed; result is not signaled 1 = Check is performed; result is signaled
	3	0 _{BIN}	inn_range_check	Signal at pin INN out of range (leaking/short to VSS or VDDB) 0 = Check is not performed; result is not signaled 1 = Check is performed; result is signaled
	4	0 _{BIN}	sens_short_check	Sensor short (INN = INP) 0 = Check is not performed; result is not signaled 1 = Check is performed; result is signaled
	5	0 _{BIN}	text_open_check	T _{EXT} pin open 0 = Check is not performed; result is not signaled 1 = Check is performed; result is signaled
	6	0 _{BIN}	text_range_check	Signal at pin T _{EXT} out of range (leaking / short to VSS or VDDB) 0 = Check is not performed; result is not signaled 1 = Check is performed; result is signaled
	7	0 _{BIN}	text_inn_short_check	T _{EXT} pin short to INN 0 = Check is not performed; result is not signaled 1 = Check is performed; result is signaled
8	0 _{BIN}	text_inp_short_check	T _{EXT} pin short to INP 0 = Check is not performed; result is not signaled 1 = Check is performed; result is signaled	

NVM Address	Word/Bit Range	Default Setting	Description	Notes/Explanations
	9	0 _{BIN}	crack_check	Broken-chip check / chipping check 0 = Check is not performed; result is not signaled 1 = Check is performed; result is signaled
	15:10	0000 _{BIN}	–	Not assigned
DAC (Output Calibration Data)				
22 _{HEX}	15:0	0000 _{HEX}	DAC10RM5V	Encoded, 16bit-quantized measurement value of DAC-output at V _{DD} =5V with 10%-DAC-excitation, digital code (199A _{HEX}). The measured DAC-voltage ^[e] can be derived as: V _{DAC10,AOUT} [V] := DAC10RM5V[dec] / 296000 + 0.39
23 _{HEX}	15:0	0000 _{HEX}	DAC90RM5V	Encoded, 16bit-quantized measurement value of DAC-output at V _{DD} =5V with 90%-DAC-excitation, digital code (E666 _{HEX}). The measured DAC-voltage ^[e] can be derived as: V _{DAC90,AOUT} [V] := DAC90RM5V[dec] / 284000 + 4.45
Free Memory (Available for Customer Use)				
24 _{HEX}	15:0	0000 _{HEX}	–	Not assigned (e.g., can be used for Cust_IDx customer identification number)
...			–	Not assigned (e.g., can be used for Cust_IDx customer identification number)
33 _{HEX}	15:0	0000 _{HEX}	–	Not assigned (e.g., can be used for Cust_IDx customer identification number)
34 _{HEX}	15:0	0000 _{HEX}	–	Not assigned (e.g., can be used for Cust_IDx customer identification number)
35 _{HEX}	15:0	-	Checksum	Generated (checksum) for the entire memory through a linear feedback shift register (LFSR); signature is checked on power-up to ensure memory content integrity

- [a] For I3C operation, this should contain the Legacy Virtual Register (LVR) information: 1X_{HEX} to Index 0. Fast-Mode is supported.
- [b] Use the *extTemp_config1* and *extTemp_config2* registers for temperature sensor related front-end configuration.
- [c] In Current Loop Operation Mode, it must be ensured that a sufficient external V_{DD}-level > 4.8V is present (e.g., with external supply transistor, such as JFET or depletion MOSFET, and extra LDO-control option).
- [d] If *pga_en_shift* is enabled, the ZSSC3240 current consumption increases by approximately 100µA. Usage is recommended for optimizing the analog front-end setup.
- [e] The IC provides the originally measured DAC-output voltage V_{DAC⁰,AOUT}[V] with V_{DD}=5V, *Aout_setup*=(001_{BIN} or 101_{BIN}) as reaction on B3_{HEX} command, see Table 33.

The NVM-consistence checksum is calculated (internally by the ZSSC3240 for the whole NVM) using the polynomial: $x^{16} + x^{15} + x^2 + 1$. The checksum verification is only realized directly after V_{DD} power-on. If the checksum is successfully verified, then the “Memory Error” status bit is set to 0_{BIN}.

6.6.3. Digital Sensor-Signal-Conditioning Mathematics

The saturation check (signalized by *SSC Calculation Unit Saturation*, see Table 16) in the ZSSC3240 detects saturation effects of the internal calculation steps, allowing the final correction output to be determined despite the saturation. It is possible to get potentially useful signal conditioning results that have had an intermediate saturation during the calculations. These cases are detectable; e.g., by observing the status bit[0] for each measurement result. Details about the saturation limits and the valid ranges for values are provided in the equations in the following sections.

The calibration math description assumes a calculation with integer numbers. The description is numerically correct concerning values, dynamic range, and resolution.

6.6.3.1. Sensor Signal Correction

The configuration parameter *SOT_curve* in NVM register 02_{HEX} selects whether second-order equations compensate for sensor nonlinearity with a parabolic or S-shaped curve. The parabolic compensation is recommended for most sensor types.

The following equations describe the available SSC capabilities. The equation terms are as follows:

- S* Corrected sensor reading output via I2C, OWI, or SPI; range [0_{HEX} to FFFFFFF_{HEX}]
- S_Raw* Raw sensor reading from ADC (after AZ correction, if selected); range [-7FFFFFF_{HEX} to 7FFFFFF_{HEX}]
- Gain_S* Sensor gain term; range [-7FFFFFF_{HEX} to 7FFFFFF_{HEX}]
- Offset_SS* Sensor offset term; range [-7FFFFFF_{HEX} to 7FFFFFF_{HEX}]
- Tcg* Temperature coefficient gain term; range [-7FFFFFF_{HEX} to 7FFFFFF_{HEX}]
- Tco* Temperature coefficient offset term; range [-7FFFFFF_{HEX} to 7FFFFFF_{HEX}]
- T_Raw* Raw temperature reading (after AZ correction); range [-7FFFFFF_{HEX} to 7FFFFFF_{HEX}]
- SOT_tcg* Second-order term for Tcg non-linearity; range [-7FFFFFF_{HEX} to 7FFFFFF_{HEX}]
- SOT_tco* Second-order term for Tco non-linearity; range [-7FFFFFF_{HEX} to 7FFFFFF_{HEX}]
- SOT_sens* Second-order term for sensor non-linearity; range [-7FFFFFF_{HEX} to 7FFFFFF_{HEX}]
- SENS_shift* Post-calibration, post-assembly offset shift; range [-7FFFFFF_{HEX} to 7FFFFFF_{HEX}]

$|\dots|$ Absolute value

$[\dots]_{ll}^{ul}$ Bound/saturation number range from *ll* to *ul*, overflow/underflow is reported as saturation in the status byte

The correction formula for the differential signal reading is represented as a two-step process depending on the *SOT_curve* setting.

Table 35. Data Format of 24-bit SSC Coefficients

Bit-Number:	23	22	21	20	...	2	1	0
Meaning, Weighting	0 = positive 1 = negative	2 ¹	2 ⁰	2 ⁻¹	...	2 ⁻¹⁹	2 ⁻²⁰	2 ⁻²¹

Table 36. Data Format of Corrected, SSC Results (S and T)

Bit-Number:	23	22	21	20	...	2	1	0
Meaning, Weighting	2 ⁰	2 ⁻¹	2 ⁻²	2 ⁻³	...	2 ⁻²¹	2 ⁻²²	2 ⁻²³

Equations for the parabolic SOT_curve setting (SOT_curve = 0):

Simplified:

$$K_1 = 2^{23} + \frac{T_Raw}{2^{23}} \cdot \left(\frac{4 \cdot SOT_tcg}{2^{23}} \cdot T_Raw + 4 \cdot Tcg \right) \quad \text{Equation 7}$$

$$K_2 = 4 \cdot Offset_S + S_raw + \frac{T_Raw}{2^{23}} \cdot \left(\frac{4 \cdot SOT_tco}{2^{23}} \cdot T_Raw + 4 \cdot Tco \right) \quad \text{Equation 8}$$

$$Z_{SP} = \frac{4 \cdot Gain_S}{2^{23}} \cdot \frac{K_1}{2^{23}} \cdot K_2 + 2^{23} \quad (\text{delimited to positive number range}) \quad \text{Equation 9}$$

$$S = \frac{Z_{SP}}{2^{23}} \cdot \left(\frac{4 \cdot SOT_sens}{2^{23}} \cdot Z_{SP} + 2^{23} \right) + SENS_shift \quad (\text{delimited to positive number range}) \quad \text{Equation 10}$$

Complete:

$$K_1 = \left[2^{23} + \frac{T_Raw}{2^{23}} \cdot \left[\left[\frac{SOT_tcg}{2^{21}} \cdot T_Raw \right]_{-2^{25}}^{2^{25}-1} + 4 \cdot Tcg \right] \right]_{-2^{25}}^{2^{25}-1} \quad \text{Equation 11}$$

$$K_2 = \left[4 \cdot Offset_S + S_raw + \frac{T_Raw}{2^{23}} \cdot \left[\left[\frac{SOT_tco}{2^{21}} \cdot T_Raw \right]_{-2^{25}}^{2^{25}-1} + 4 \cdot Tco \right] \right]_{-2^{25}}^{2^{25}-1} \quad \text{Equation 12}$$

$$Z_{SP} = \left[\left[\frac{Gain_S}{2^{21}} \cdot \left[\left[\frac{K_1}{2^{23}} \cdot K_2 \right]_{-2^{25}}^{2^{25}-1} + 2^{23} \right] \right]_{-2^{25}}^{2^{25}-1} \right]_0^{2^{25}-1} \quad \text{Equation 13}$$

$$S = \left[\frac{Z_{SP}}{2^{23}} \cdot \left[\left[\frac{SOT_sens}{2^{21}} \cdot Z_{SP} \right]_{-2^{25}}^{2^{25}-1} + 2^{23} \right] + SENS_shift \right]_0^{2^{24}-1} \quad \text{Equation 14}$$

Equations for the S-shaped SOT_curve setting (SOT_curve = 1):

Simplified:

$$Z_{SS} = \frac{4 \cdot Gain_S}{2^{23}} \cdot \frac{K_1}{2^{23}} \cdot K_2 \quad (K_1 \text{ and } K_2 \text{ according to Equation 7 and Error! Reference source not found.}) \quad \text{Equation 15}$$

$$S = \frac{Z_{SS}}{2^{23}} \cdot \left(\frac{4 \cdot SOT_sens}{2^{23}} \cdot |Z_{SS}| + 2^{23} \right) + SENS_shift \quad (\text{delimited to positive number range}) \quad \text{Equation 16}$$

Complete:

$$Z_{SS} = \left[\left[\frac{Gain_S}{2^{21}} \cdot \left[\left[\frac{K_1}{2^{23}} \cdot K_2 \right]_{-2^{25}}^{2^{25}-1} \right]_{-2^{25}}^{2^{25}-1} \right]_{-2^{25}}^{2^{25}-1} \right]_0^{2^{25}-1} \quad \text{Equation 17}$$

$$S = \left[\left[\frac{Z_{SS}}{2^{23}} \cdot \left[\left[\frac{SOT_sens}{2^{21}} \cdot |Z_{SS}| \right]_{-2^{25}}^{2^{25}-1} + 2^{23} \right]_{-2^{25}}^{2^{25}-1} + 2^{23} + SENS_shift \right]_{-2^{25}}^{2^{25}-1} \right]_0^{2^{24}-1} \quad \text{Equation 18}$$

6.6.3.2. Temperature Signal Correction

Temperature is measured either internally by the ZSSC3240 or through an additional external element or by means of a combination of ZSSC3240-internal and external temperature sensing capabilities; see sections 6.2.3 and 6.2.4. Temperature correction contains both linear gain and offset terms as well as a second-order term to correct for any nonlinearities. For temperature, second-order compensation for nonlinearity is always parabolic.

The correction equation terms are as follows:

T Corrected temperature sensor reading output via digital interface; range [0_{HEX} to FFFFFFF_{HEX}]

$Gain_T$ Gain coefficient for temperature; range [-7FFFFFF_{HEX} to 7FFFFFF_{HEX}]

T_Raw Raw temperature reading after AZ correction; range [-7FFFFFF_{HEX} to 7FFFFFF_{HEX}]

$Offset_T$ Offset coefficient for temperature; range [-7FFFFFF_{HEX} to 0x7FFFFFF_{HEX}]

SOT_T Second-order term for temperature source nonlinearity; range [-7FFFFFF_{HEX} to 7FFFFFF_{HEX}]

T_Shift Shift for post-calibration/post-assembly offset compensation [-7FFFFFF_{HEX} to 7FFFFFF_{HEX}]

The correction formula is best represented as a two-step process as follows:

Simplified:

$$Z_T = \frac{4 \cdot Gain_T}{2^{23}} \cdot (T_Raw + 4 \cdot Offset_T) + 2^{23} \quad (\text{delimited to positive number range}) \quad \text{Equation 19}$$

$$T = \frac{Z_T}{2^{23}} \cdot \left(\frac{4 \cdot SOT_T}{2^{23}} \cdot Z_T + 2^{23} \right) + T_shift \quad (\text{delimited to positive number range}) \quad \text{Equation 20}$$

Complete:

$$Z_T = \left[\left[\frac{Gain_T}{2^{21}} \cdot [T_Raw + 4 \cdot Offset_T] \right]_{-2^{25}}^{2^{25}-1} + 2^{23} \right]_{0}^{2^{25}-1} \quad \text{Equation 21}$$

$$T = \left[\frac{Z_T}{2^{23}} \cdot \left[\left[\frac{SOT_T}{2^{21}} \cdot Z_T \right]_{-2^{25}}^{2^{25}-1} + 2^{23} \right]_{-2^{25}}^{2^{25}-1} + T_shift \right]_{0}^{2^{24}-1} \quad \text{Equation 22}$$

6.7 External, Extra LDO (LDOctrl) for Applications for > 5.5V

The ZSSC3240 has integrated voltage regulators that generate separate analog and digital ZSSC3240-internal voltages for any valid external supply voltage, V_{DD} (2.7V to 5.5V). For proper ZSSC3240 function, the directly applied supply voltage should not exceed the maximum V_{DD} limit.

The ZSSC3240 also supports applications with higher application-inherent supply voltages greater than 5.5V. The ZSSC3240 provides a voltage regulation signal at the LDOctrl pin and a programmable IC supply, i.e. V_{DD} -level regulation target level, $V_{DD_ldoctrl_target}$ in the SSF2 register. The use of an additional external regulator transistor (by means of, for example JFET, depletion MOSFET, or comparable) further improves the power-supply rejection ratio (PSRR); i.e., it reduces effects from the external supply voltage onto the sensor measurement results in addition to the ZSSC3240-internal regulator properties. If the external extra supply regulation is not used or needed, the respective feature should be disabled by $disable_ldoctrl = 1_{BIN}$.

Table 37. IC Supply, V_{DD} Target Level Selection with External Voltage Regulation, External LDO

$V_{DD_ldoctrl_target}$		V_{DD} Target Level	Notes
Bit[1]	Bit[0]		
0	0	4.8V	
0	1	5.0V	
1	0	5.2V	Recommended, typical settings.
1	1	5.4V	

Recommendation: Use the clamping diode at V_{DD} (to FB for current-loop output configurations or to VSS in all other cases with external LDO as shown by gray dashed line in Figure 22) to ensure over-voltage protection at the initial application power-on. The external transistor, depicted as JFET¹ can be a real JFET type, or, for example, depletion MOSFET and comparable. It must be selected such that the drain-source voltage can be at least $V_{DDext} - 5V$.

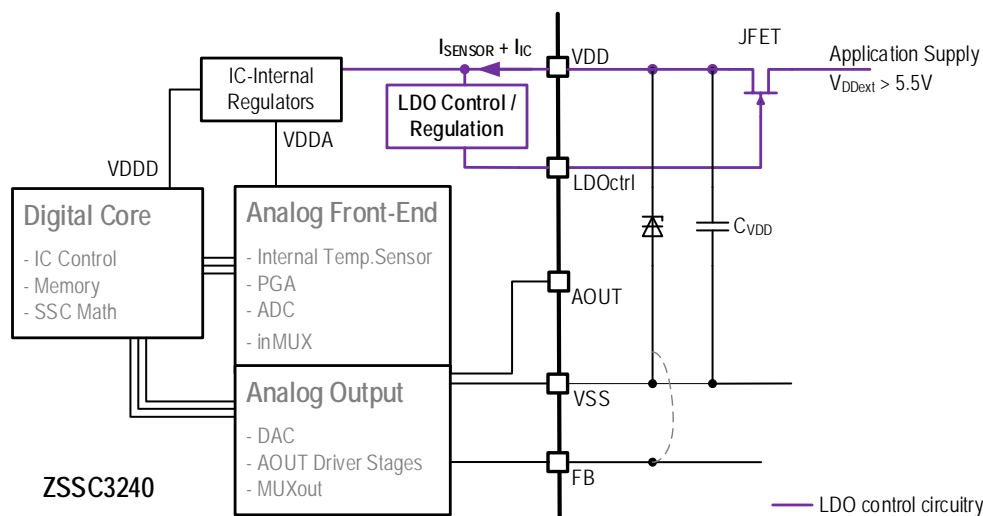

Figure 23. LDOctrl Application Topology

Table 38. External LDO Operating Conditions

Symbol	Parameter	Minimum	Typical	Maximum	Units
C_{ctrl}	Allowed parasitic capacitance at LDOctrl pin	–	150	500	pF
C_{VDD}	Buffer/filter capacitance between V_{DD} and VSS	80	100	120	nF

¹ Depending on the $V_{DDext}>5.5V$ application main supply, different external transistors can be applied, for example BSS169 (Infineon), DN3545N8 (Microchip-Supertex), MMBF4392LT1G (Fairchild), etc.

7. Calibration

Calibration essentially involves collecting raw signal and temperature data from the sensor-ZSSC3240 system for different known sensor-element values (i.e., for a resistive bridge or an absolute voltage source) and temperatures. This raw data can then be processed by the calibration master (assumed to be the user's computer), and the calculated calibration coefficients can then be written to on-chip memory.

Brief overview of the three main steps involved in calibrating the ZSSC3240:

1. *Assigning a unique identification to the ZSSC3240.* This identification is written to shadow RAM and programmed in NVM. This unique identification can be stored in the two 16-bit registers dedicated to the customer ID. It can be used as an index into a database stored on the calibration PC. This database will contain all the raw values of the connected sensor-element readings and temperature readings for that part, as well as the known sensor-element measurand conditions and temperature to which the sensor-element was exposed.
2. *Data collection.* Data collection involves getting uncorrected (raw) data from the external sensor at different known measurand values and temperatures. Then this data is stored on the calibration master using the unique identification of the device as the index to the database.
3. *Coefficient calculation and storage in NVM.* After enough data points have been collected to calculate all the desired coefficients, the coefficients can be calculated by the calibration master. Then the coefficients can be programmed to the memory.
4. *Result.* The sensor signal and the characteristic temperature effect on output will be linearized according to the setup-dependent maximum output range.

It is essential to perform the calibration with a fixed programming setup during the data collection phase.

Strong recommendation: To prevent any accidental misprocessing, keep the sensor front-end NVM setup (registers *SSF1*, *SSF2*, *SM_config1*, *SM_config2*, *extTemp_config1*, *extTemp_config2*) stable during the entire calibration process as well as in the subsequent operation.

Note: A ZSSC3240 calibration only fits the setup used during its calibration. Changes of functional parameters after a successful calibration can decrease the precision and accuracy performance of the ZSSC3240 as well as of the entire application.

8. Package Outline Drawings

The package outline drawings are appended at the end of this document and are accessible from the link below. The package information is the most current data available.

<https://www.idt.com/document/psc/24-vfqfn-package-outline-drawing-40-x-40-x-085-mm-body05mm-pitch-epad-25-x-25-wettable-flank-side>

9. Marking Diagram

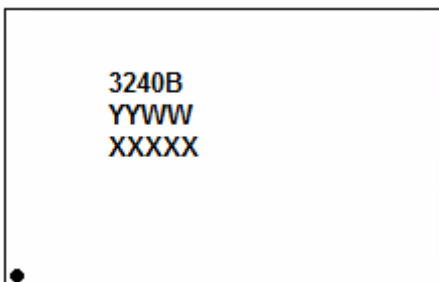

1. Line 1 is the truncated part number.
2. Line 2 – “YYWW” are the last two digits of the year and week that the part was assembled.
3. Line 3 – “XXXXX” denotes assembly lot number.

10. Ordering Information

Orderable Part Number	Description and Package	MSL Rating	Carrier Type	Temperature
ZSSC3240CC1B	DICE on 304µm wafer no inking		Wafer Box	-40 to 85°C
ZSSC3240CC2B	DICE on 725µm wafer no inking		Wafer Box	-40 to 85°C
ZSSC3240CC5B	DICE on 304µm wafer with inking		Wafer Box	-40 to 85°C
ZSSC3240CC6B	DICE on 725µm wafer with inking		Wafer Box	-40 to 85°C
ZSSC3240CC3R	4 × 4 mm ² 24-QFN	MSL1	13 inch Reel	-40 to 85°C
ZSSC3240CI1B	DICE on 304µm wafer no inking		Wafer Box	-40 to 125°C
ZSSC3240CI2B	DICE on 725µm wafer no inking		Wafer Box	-40 to 125°C
ZSSC3240CI5B	DICE on 304µm wafer with inking		Wafer Box	-40 to 125°C
ZSSC3240CI6B	DICE on 725µm wafer with inking		Wafer Box	-40 to 125°C
ZSSC3240CI3R	4 × 4 mm ² 24-QFN	MSL1	13 inch Reel	-40 to 125°C
ZSSC3240CI3W	4 × 4 mm ² 24-QFN	MSL1	7 inch Reel	-40 to 125°C
ZSSC3240KIT	Modular ZSSC3240 SSC Evaluation Kit including three interconnecting boards, five ZSSC3240 24-VFPQFN samples, and cable. Software is available for download on www.IDT.com/ZSSC3240 .			

11. Glossary

Term	Description
A2D	Analog-to-Digital
ACK	Acknowledge (interface's protocol indicator for successful data/command transfer)
ADC	Analog-to-Digital Converter or Conversion
AGND	Analog-Ground, ZSSC3240-internal ... $VDDA_{int}/2$
AZ	Auto-Zero (unspecific)
AZS	Auto-Zero Measurement for (External) Sensor Path
AZT	Auto-Zero Measurement for (External or Internal) Temperature Path
CLK	Clock
DAC	Digital-to-Analog Converter or Conversion
EMC	Electromagnetic Compatibility
EMI	Electromagnetic Immision (Immunity), i.e. immunity on spuriously coupled high-frequency disturbances
EOC	End of Conversion
FSO	Full Scale Output (value in percent relative to the ADC maximum output code; resolution dependent)
LFSR	Linear Feedback Shift Register
LSB	Least Significant Bit
MSB	Most Significant Bit
MSL	Moisture Sensitivity Level
NACK	Not Acknowledge (interface's protocol indicator for unsuccessful data/command transfer)
NVM	Nonvolatile Memory
Op amp	Operating Amplifier
PGA	Programmable Gain Amplifier
POR	Power-On Reset
PPT	Parts-per-Thousand, 1PPT=1/1000
PSRR	Power Supply (Disturbance) Rejection Ratio
PTC	Positive Temperature Coefficient (sensing element)
S	SSC-corrected Sensor Readout / Result
SM	Sensor Measurement
SOT	Second Order Term
SSF	Smart-Sensor Function (specific NVM registers)
T	SSC-corrected (extra) Temperature Readout / Result
TC	Temperature Coefficient

12. Revision History

Revision Date	Description of Change
Apr.15.20	Initial release

