

Wireless LAN Module Evaluation Board

WBSACVLAY-WX



This evaluation board is an object for experiment of operation, and does not guarantee quality. Also, the circuits, components, and software used on this evaluation board may not be the latest.

ATTENTION: This module has an API (Application Programming Interface) Specification that is under Japan export control. Depending on the customer's country and application (e.g. weapons), TAIYO YUDEN CO., LTD. may not be able to provide the API Specification to all customers. Please contact your local TAIYO YUDEN CO., LTD. sales office for additional information.

To contact your local sales office and for additional product information, please visit www.ty-top.com.

TABLE OF CONTENTS

1. Introduction	4
2. Target Module	4
3. Accessories.....	4
4. Recommended Operating Environment.....	4
5. Block Diagram.....	5
6. Evaluation Board Layout	5
7. Pin Descriptions.....	6
8. Software	7
9. Example of Connection for Evaluation.....	7
10. Schematic of Evaluation Board.....	9

Rev. Records

17-Mar. 2020> Ver. 1.0 Released

1. Introduction

The evaluation board is designed for customers to easily work with “WYSACVLAY-WX”, **MCU embedded Wireless LAN** module, for functional evaluation purpose. This document describes the hardware configuration and the usage.

2. Target Module

WYSACVLAY-WX

3. Accessories

1	Evaluation Board (WBSACVLAY-WX)	1 piece
---	---------------------------------	---------

4. Recommended Operating Environment

HOST PC:

CPU: 1000MHz or higher

Interface: USB

DC Power Supply: External power supply is not required since 5V power is supplied via USB connection.

5. Block Diagram

WBSACVLAY-WX has several connectors. J4 (USB mini B connector) is used for USB signal that is converted from UART by FT232RQ. The embedded application running on WYSACVLAY uses UART as a host interface usually. Solder bridge port (SB1-4) are used to switch UART interfaces (U9 or J2). J1 and J6 are jumper connector to switch power sources (from LDO or from J2/J3).

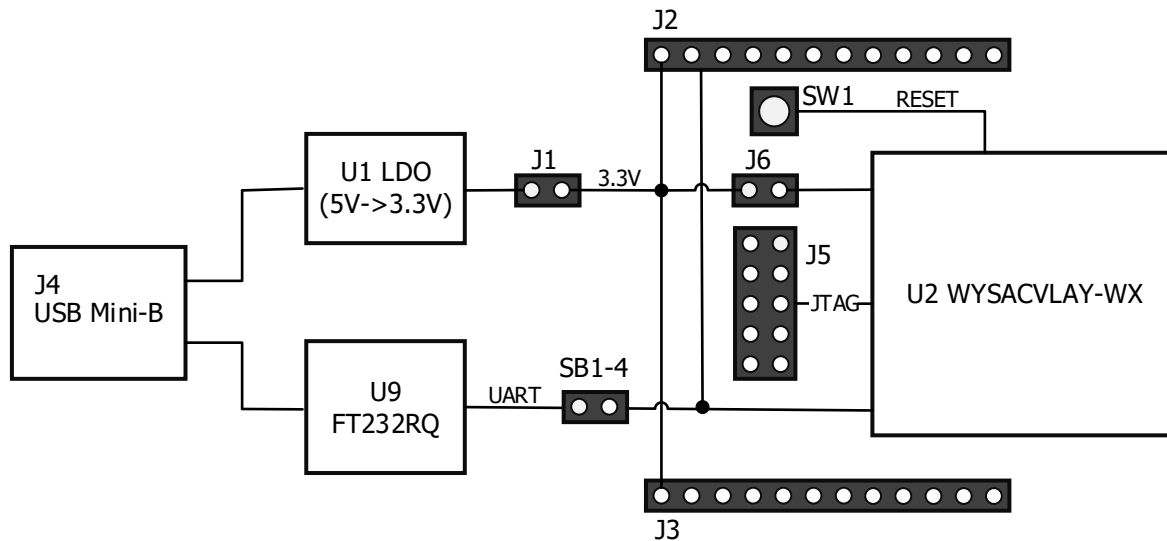

6. Evaluation Board Layout

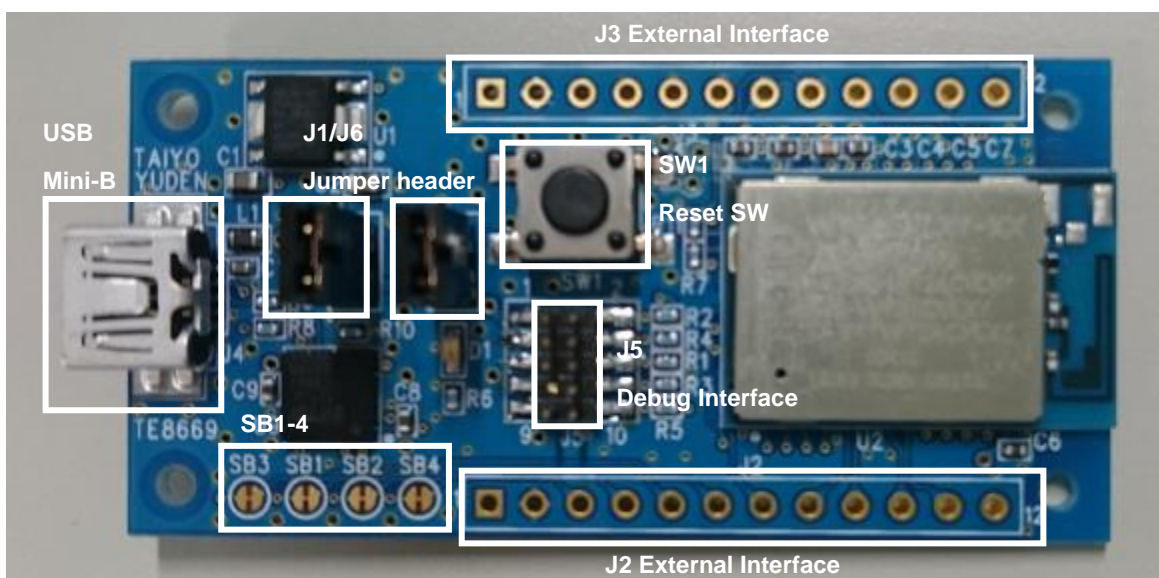

7. Pin Description of Evaluation Board**J2 External Interface**

Pin#	Name	Direction	Description
1	EX3V3_PWR	-	Power Supply 3.3V
2	GND	-	Ground
3	UART1_TXD	Output	UART1 TXD signal
4	UART1_RTSN	Output	UART1 RTS signal Hardware flow control is active by default with TAIYO YUDEN CO., LTD. standard application
5	UART1_RXD	Input	UART1 RXD signal
6	UART1_CTSN	Input	UART1 CTS signal Hardware flow control is active by default with TAIYO YUDEN CO., LTD. standard application
7	GPIO41	Input/Output	not used by TAIYO YUDEN CO., LTD. standard application
8	SPI_CLK	Input/Output	not used by TAIYO YUDEN CO., LTD. standard application
9	SPI_SEL	Input/Output	not used by TAIYO YUDEN CO., LTD. standard application
10	SPI_TXD	Output	not used by TAIYO YUDEN CO., LTD. standard application
11	SPI_RXD	Input	not used by TAIYO YUDEN CO., LTD. standard application
12	SPI_RDY	Input/Output	not used by TAIYO YUDEN CO., LTD. standard application

J3 External Interface

Pin#	Name	Direction	Description
1	EX3V3_PWR	-	Power Supply 3.3V
2	GND	-	Ground
3	UART0_TXD	Output	UART0 TXD signal
4	UART0_RXD	Input	UART0 RXD signal
5	I2C_SDA	Input/Output	not used by TAIYO YUDEN CO., LTD. standard application
6	I2C_SCL	Input/Output	not used by TAIYO YUDEN CO., LTD. standard application
7	WAKEUP0	Input	
8	WAKEUP1	Input	
9	GPIO41	Input/Output	not used by TAIYO YUDEN CO., LTD. standard application
10	NC_CON5	-	not used by TAIYO YUDEN CO., LTD. standard application
11	NC_CON4	-	not used by TAIYO YUDEN CO., LTD. standard application
12	RESET	Input	Reset signal (Active Low)

J5 Debug Interface (not used by TAIYO YUDEN CO., LTD. standard application)

Pin#	Name	Direction	Description
1	EX3V3_PWR	-	Power (to monitor power supply voltage)
2	TMS	Input	JTAG TMS signal
3	GND	-	Ground
4	TCK	Input	JTAG TCK signal
5	GND	-	Ground
6	TDO	Output	JTAG TDO signal
7	NC	-	
8	TDI	Input	JTAG TDI signal
9	NC	-	
10	TRSTN	Input	JTAG target reset signal

8. Software

- Device Drivers for FT232RQ:

FT232RQ USB-UART converter is built in this board. FT232RQ is made by Future Technology Devices International Limited. Download USB driver from following URL.

<http://www.ftdichip.com/>

9. Example of Connection for Evaluation

Case1. With PC

- Put jumper on J1 and J6 and connect USB cable
- Connect USB cable between PC and WBSACLVXAY-WX
- Run serial terminal software. Default baud rate of the module is 115.2kbps. Please configure baud rate of serial terminal software.

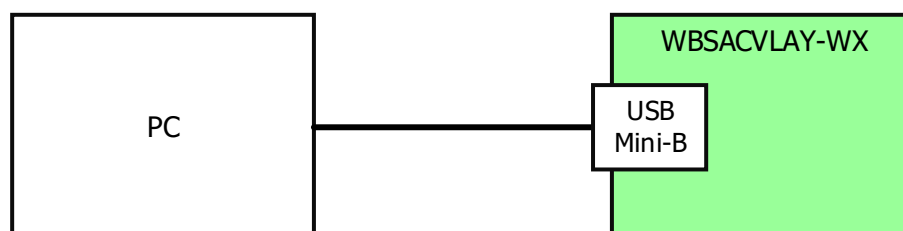

Case2. Using external interface (with other MCU)

- Cut the line between the land patterns of Solder Bridge SB1 – SB4 in order to disconnect the UART line of the module from FT232RQ.
- Put jumper on J6 only and supply power source (3.3V) to J2/J3 pin#1.
- **DO NOT** put jumper on J1 in this case. If do that, MCU and WBSACVLAY-WX may be broken.

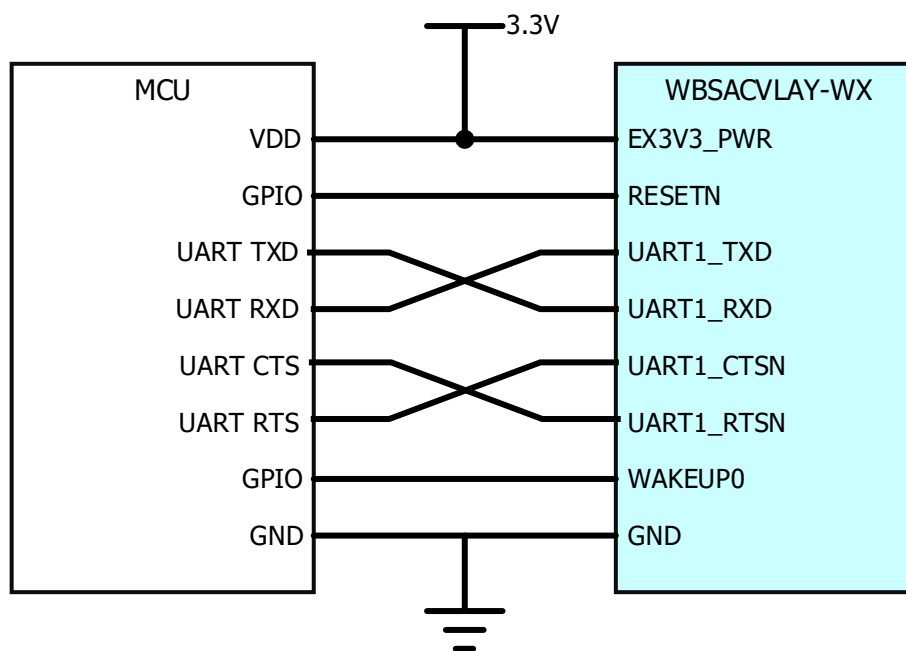
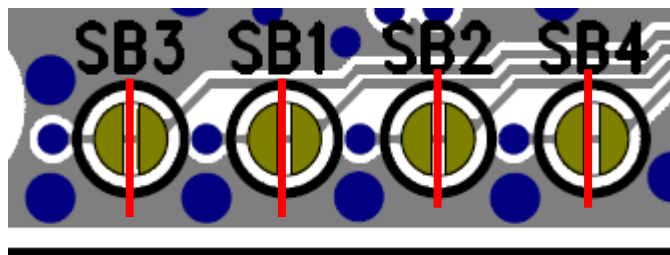

REV	ECO	APPROVED	DESCRIPTION	DATE

10. Schematic of evaluation board

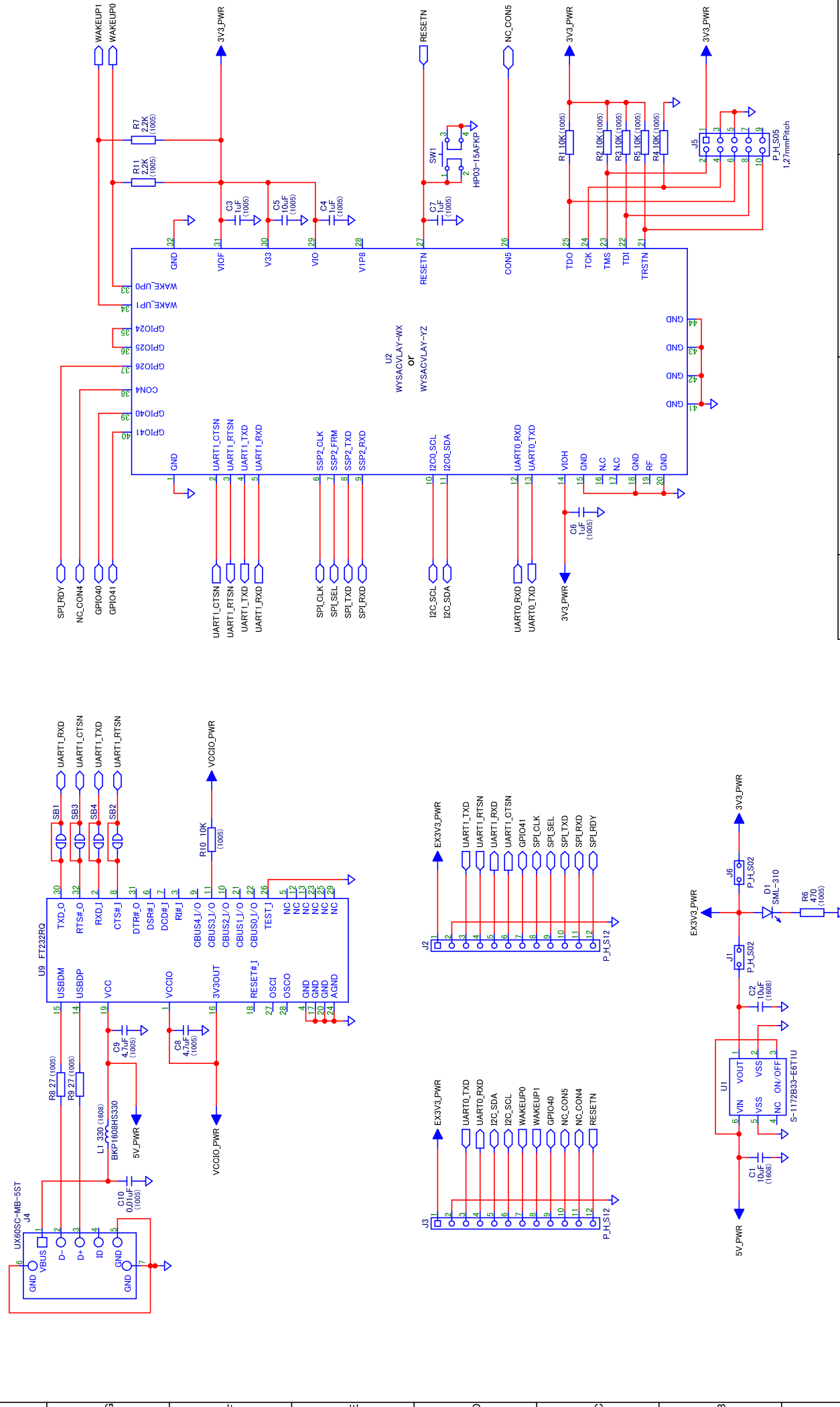

APPROVED	TITLE	DOCUMENT NO.
	Circuit schematic	HD-MC-BTE8669
CHECKED		
DRAWN		
DESIGNED		

