

LR06 - PLASTIC FLOAT SWITCH

Method of Operation

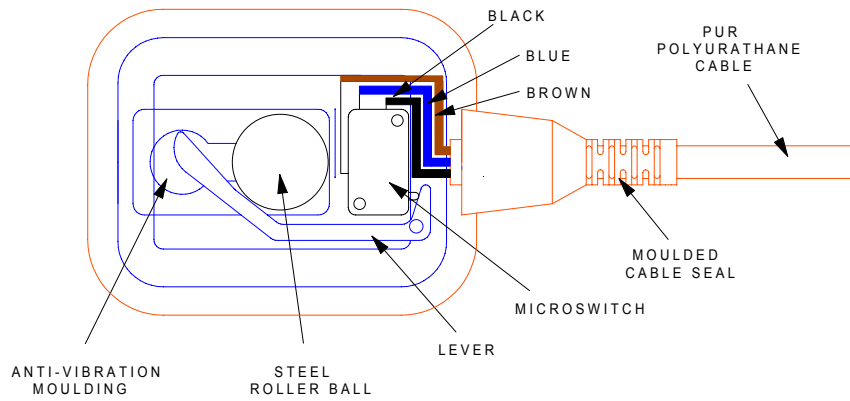

The micro-switch assembly inside the float, axially mounted in line with the weight, changes contacts according to the float's position, as in the diagram below. Therefore as the liquid level drops or rises slowly, a pump or flow control suitably connected, can be switched in or out to maintain an average level of the liquid. By connecting only one side of the switch, the unit can be also used to fill or empty the tank as required.

Dimensions, in mm, do not take into consideration any lateral swing of the cable.

Contact rating: 250V 15A, non-inductive.
250V 10A, inductive. 1.3 HP

NOTE: Local regulations may limit the voltage.

Max. temperature 70° C

Max. submerged depth 20 metres

Compressive Strength 482 KN/m² (70 lbf/in²)

Operational in specific gravities from 0.9 to 1.3

A comprehensive list of chemical resistances for the LR06 float switch is available on request.

When ordering please specify part numbers.

Type	Part Number	Weight (Approx.)
5 metre cable	LR06-L05M	0.7 Kg
10 metre cable	LR06-L10M	1.2 Kg
20 metre cable	LR06-L20M	2.2 Kg
LR03/5/6/7 Weight		275 g

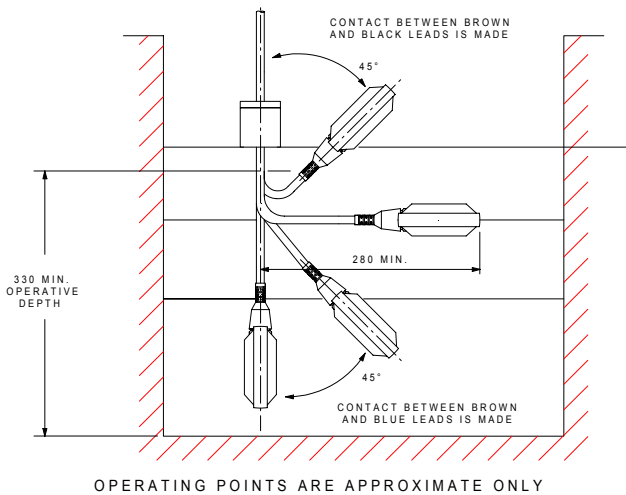

Connection diagram for automatically emptying tank

Connection diagram for automatically refilling tank

