

Toggle

DOUBLE POLE

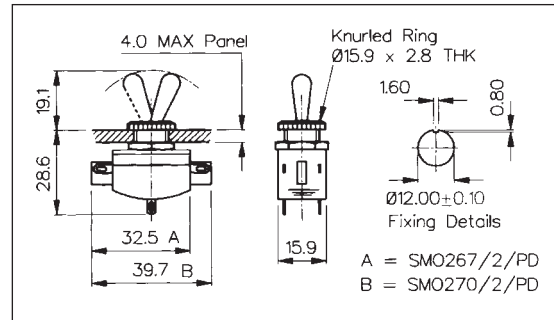

- SM0267/2/PD - D.P.M.B
SM0270/2/PD - D.P.C.O
- Solder tags
- 2A, 250V a.c.



DOUBLE POLE



- 6.3mm tabs or Screw Terminals
- 10A, 250V a.c.

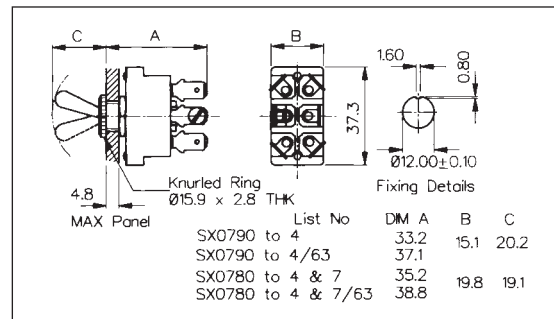

Double Pole List No.

Description



Double Pole List No.	Description	1	2	3
SX0780	Change-over. Centre off	ON	OFF	ON
SX0782	Change-over. Centre off Two position biased off	ON	OFF	ON
SX0783	Change-over Two positions only	ON	-	ON
SX0784	ON/OFF Two positions only	OFF	-	ON
SX0787	Change-over. Two positions only biased to one position	ON	-	ON

Specification

SM0267/2/PD, SM0270/2/PD

SX0780 Series

Terminations:	Solder Tags	Screw Terminals
Switching:	SM0267/2/PD - D.P.M.B. 2 pairs of contacts SM0270/2/PD - D.P.C.O. 3 pairs of contacts (Quick Make/Break)	See table for types Slow Make, Slow Break
Max. Rating:	2A, 250V a.c.	10A, 250V a.c. 10A, 0-28V d.c. (non-reactive circuits)
Contact Resistance:	<10m Ω	<10m Ω
Insulation Resistance:	>10 ³ M Ω	>10 ³ M Ω
Dielectric Strength:	>3.5kV a.c.	>2.5kV a.c.
Operating Temp. Range:	-20°C to +70°C	-20°C to +85°C
Materials:		
Mouldings:	Phenolic	Glass Filled Polyester
Tags:	Copper, Silver Plated	Brass, Silver Plated
Contacts/Terms:	Copper Silver Alloy	Copper with Silver face
Variants:	-	/63 (6.3mm tabs)
Accessories:	SX0550 (see page 175)	SX0550 (see page 175)