

BGSA20UGL8

High RF Voltage Dual SPST Antenna Switch

Features

- Dual SPST designed for high-linearity antenna aperture switching and RF tuning applications
- Low R_{ON} resistance of 2.3Ω at each port in ON state
- Low C_{OFF} capacitance of 200 fF at each port in OFF state
- > 80 V RF voltage OFF state handling
- Low harmonic generation
- GPIO control interface - including 4 control states
- Supply voltage range: 1.65 to 3.6 V
- No RF parameter change within supply voltage range
- Small form factor 1.1 mm x 1.1 mm (MSL1, 260° C per JEDEC J-STD-020)
- Suitable for EDGE/CDMA/WCDMA/C2K/LTE/5G Applications
- RoHS and WEEE compliant package

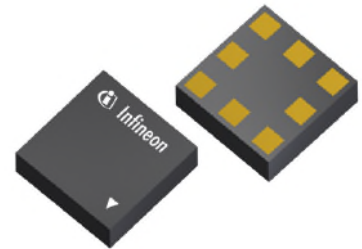

Description

The BGSA20UGL8 is a versatile Dual Single-Pole Single-Throw (SPST) RF antenna shunt aperture switch optimized for low C_{OFF} as well as low R_{ON} enabling applications up to 6.0 GHz. This single supply chip integrates 2 digital control pins. Unlike GaAs technology, the 0.1 dB compression point exceeds the switch maximum input power level, resulting in linear performance at all signal levels, and external DC blocking capacitors at the RF ports are only required if DC voltage is applied externally. Due to its very high RF voltage ruggedness, it is suited for switching any reactive devices such as inductors and capacitors in RF matching circuits without significant losses in quality factors.

High RF Voltage Dual SPST Antenna Switch

Block diagram and ordering information

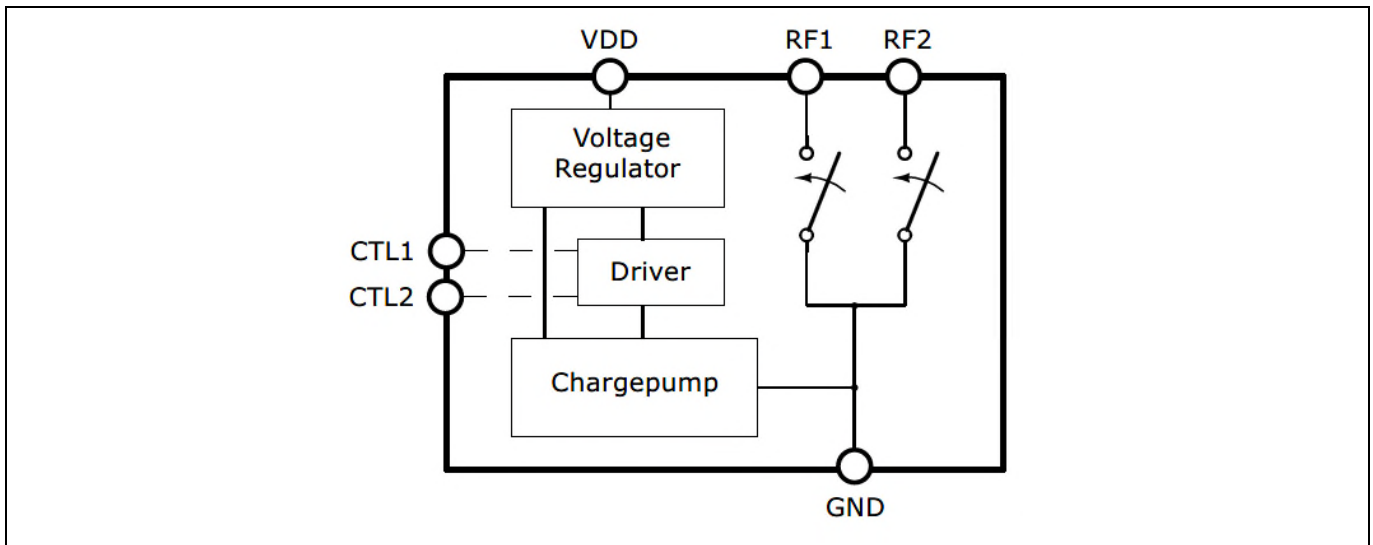

Figure 1 BGS20UGL8 Block diagram

Table 1 Ordering Information

Type	Package	Marking
BGS20UGL8	TSNP-8-1	U



WEEE Compliant
Package



Halogen-Free
PB Free



RoHS

Trademarks

All referenced product or service names and trademarks are the property of their respective owners.

Edition 2019-09-16

Published by

Infineon Technologies AG
81726 München, Germany

© 2020 Infineon Technologies AG.
All Rights Reserved.

Do you have a question about this
document?

Email: erratum@infineon.com

Document reference

ifx1

IMPORTANT NOTICE

The information given in this document shall in no event be regarded as a guarantee of conditions or characteristics ("Beschaffenheitsgarantie").

With respect to any examples, hints or any typical values stated herein and/or any information regarding the application of the product, Infineon Technologies hereby disclaims any and all warranties and liabilities of any kind, including without limitation warranties of non-infringement of intellectual property rights of any third party.

In addition, any information given in this document is subject to customer's compliance with its obligations stated in this document and any applicable legal requirements, norms and standards concerning customer's products and any use of the product of Infineon Technologies in customer's applications.

The data contained in this document is exclusively intended for technically trained staff. It is the responsibility of customer's technical departments to evaluate the suitability of the product for the intended application and the completeness of the product information given in this document with respect to such application.

For further information on the product, technology, delivery terms and conditions and prices please contact your nearest Infineon Technologies office (www.infineon.com).

WARNINGS

Due to technical requirements products may contain dangerous substances. For information on the types in question please contact your nearest Infineon Technologies office.

Except as otherwise explicitly approved by Infineon Technologies in a written document signed by authorized representatives of Infineon Technologies, Infineon Technologies' products may not be used in any applications where a failure of the product or any consequences of the use thereof can reasonably be expected to result in personal injury.