



ELECTRONICS



Magnifier Lamp Catalog

2018



Table of Contents

LED125.....	3
LED128.....	4
LED172.....	5
LED210.....	6
LED250B.....	7
LED360.....	8
LED600A.....	9
LED625.....	10
LED645.....	11
LED695.....	12
LED850.....	13
LED1000.....	14
LUX-250B / LUX-250W.....	15
LUX-300.....	16
LUX-350.....	17
LUX-400.....	18
LUX-450.....	19
LUX-520 / LUX-520W.....	20
LUX-750.....	21
LUX-780.....	22
LUX-900.....	23



3 DIOPTER LED MAGNIFIER LAMP

The LED125 is the perfect desktop lamp for home, office or professional medical applications.

This unit features a powerful ring of 45 ultra bright LEDs (Light Emitting Diodes) that offer ultra bright white light with 30% less current draw than fluorescent bulbs and as bright as daylight!

The 39" adjustable swing arm design allows freedom of movement in any direction.

The head houses a powerful 5" round 3 Diopter glass magnifying lens.

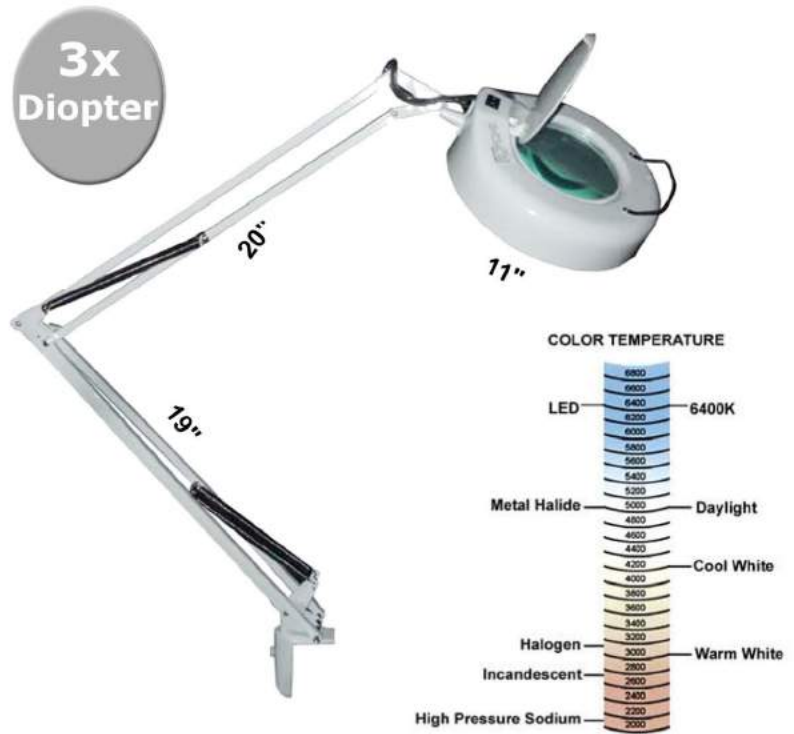

Model: LED125

Specifications:

- 39" Spring Balanced Arm: Stays Set in Any Position
- 45 Ultra Bright LEDs
- 3 Diopter 5" Round Glass Lens
- Color: White
- Power: 9.4W
- Color Temperature: 4786K (Daylight)
- CE/ETL Approved
100V-240V Power Supply
- Master Carton Weight: 7 LBS
- Master Carton Size: 33½"(L) x 14½"(W) x 5¾"(D)

Features:

- 45 Ultra Bright White LED Light
- 30% Less Current Draw Than Fluorescent Bulbs
- Lightweight Design
- Individual Display Box



MG Electronics - 32 Ranick Road, Hauppauge, NY 11788-4295

Phone: (631) 582-3400
www.mgelectronics.com

Fax: (631) 582-3229
sales@mgelectronics.com



8 DIOPTER LED MAGNIFIER LAMP

The LED128 is the perfect desktop lamp for home, office or professional medical applications.

This unit features a powerful ring of 45 ultra bright LEDs (Light Emitting Diodes) that offer ultra bright white light with 30% less current draw than fluorescent bulbs and as bright as daylight!

The 36.8" adjustable swing arm design allows freedom of movement in any direction.

The head houses a powerful 5" round 8 Diopter glass magnifying lens.

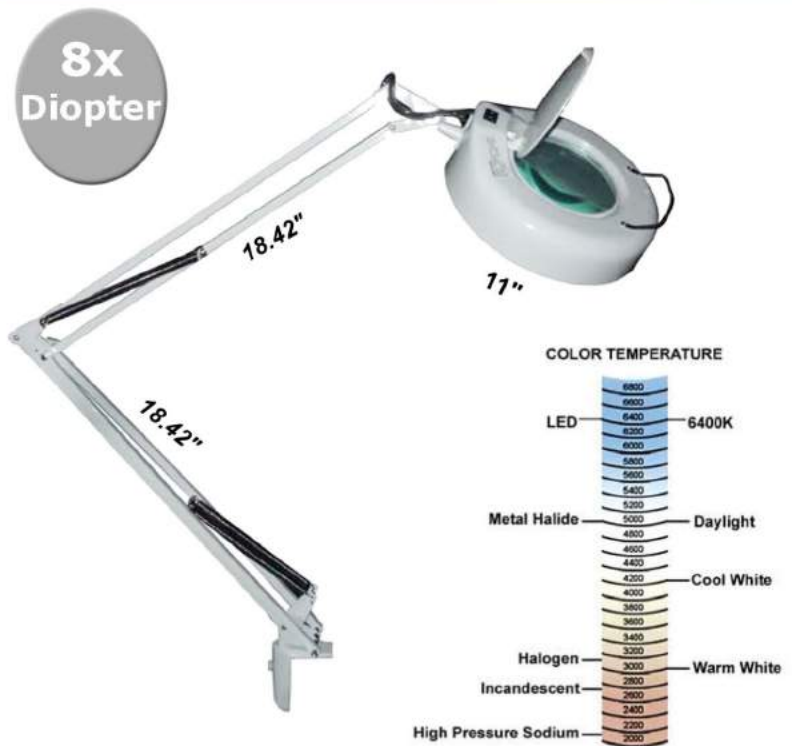

Model: LED128

Specifications:

- 36.8" Spring Balanced Arm: Stays Set in Any Position
- 45 Ultra Bright LEDs
- 8 Diopter 5" Round Glass Lens
- Color: White
- Power: 9.4W
- Color Temperature: 4786K (Daylight)
- ETL/UL Approved 100V-240V Power Supply
- Master Carton Weight: 8 LBS
- Master Carton Size: 33½"(L) x 14½"(W) x 5¾"(D)

Features:

- 45 Ultra Bright White LED Light
- 30% Less Current Draw Than Fluorescent Bulbs
- Lightweight Design
- Individual Display Box



MG Electronics - 32 Ranick Road, Hauppauge, NY 11788-4295

Phone: (631) 582-3400
www.mgelectronics.com

Fax: (631) 582-3229
sales@mgelectronics.com



3 DIOPTER LED MAGNIFIER LAMP

The LED172 is the ideal desktop lamp for home, office or professional medical applications.

This unit features 36 ultra bright LEDs (Light Emitting Diodes) that offer ultra bright white light with 30% less current draw than fluorescent bulbs and as bright as daylight!

The 36" adjustable swing arm design allows freedom of movement in any direction.

The head houses a powerful 7" x 5" 3 Diopter glass magnifying lens.

3x
Diopter



Model: LED172

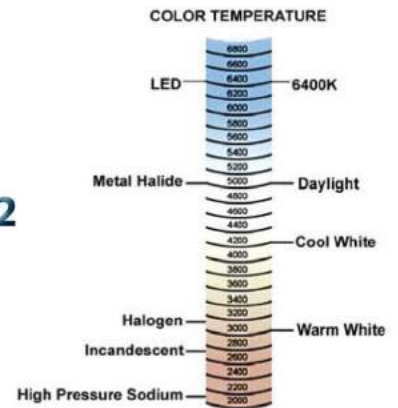

Specifications:

- 36" Spring Balanced Arm: Stays Set in Any Position
- 36 Ultra Bright LEDs
- 3 Diopter 7" x 5" Glass Lens
- Color: White
- Power: 7.6W
- Color Temperature: 6400K (Daylight)
- CE/ETL/UL Approved 100V-240V Power Supply
- Master Carton Weight: 10 LBS
- Master Carton Size: 23¾"(L) x 10½"(W) x 6¼"(D)

Features:

- 36 Ultra Bright White LED Light
- 30% Less Current Draw Than Fluorescent Bulbs
- Lightweight Design
- Individual Display Box



MG Electronics - 32 Ranick Road, Hauppauge, NY 11788-4295

Phone: (631) 582-3400

www.mgelectronics.com

Fax: (631) 582-3229

sales@mgelectronics.com



3/5 DIOPTER LED MAGNIFIER LAMP

The LED210 is the perfect desktop lamp for home, office or professional medical applications.

This unit features a powerful ring of 45 ultra bright LEDs (Light Emitting Diodes) that offer ultra bright white light with 30% less current draw than fluorescent bulbs and as bright as daylight!

The 32" adjustable swing arm design allows freedom of movement in any direction.

The head houses a powerful 5" round 3 Diopter glass magnifying lens.

Package also includes a 5 Diopter 5" magnifying lens.



Model: LED210

Specifications:

- 32" Spring Balanced Arm: Stays Set in Any Position
- 45 Ultra Bright LEDs
- 3 Diopter 5" Round Glass Lens Installed
- 5 Diopter 5" Round Glass Lens Interchangeable
- Color: White
- Power: 9.4W
- Color Temperature: 6400K (Daylight)
- CE/ETL/UL Approved 100V-240V Power Supply
- Master Carton Weight: 6 LBS
- Master Carton Size: 20"(L) x 11½"(W) x 5¼"(D)

Features:

- 45 Ultra Bright White LED Light
- 30% Less Current Draw Than Fluorescent Bulbs
- Lightweight Design
- Individual Display Box



MG Electronics - 32 Ranick Road, Hauppauge, NY 11788-4295

Phone: (631) 582-3400

www.mgelectronics.com

Fax: (631) 582-3229

sales@mgelectronics.com



3 DIOPTER LED CLIP-ON MAGNIFIER LAMP

The LED250B is the perfect desktop lamp for hobbyists and home offices.

This unit features a powerful ring of 24 ultra bright LEDs (Light Emitting Diodes) that offer ultra bright white light with 30% less current draw than fluorescent bulbs and as bright as daylight!

The 14.5" adjustable swing arm design allows freedom of movement in any direction.

The head houses a powerful 3 1/2" round 3 Diopter glass magnifying lens.

Spring-loaded clamp securely fastens lamp to desk or table up to 1 1/2" thick.



Model: LED250B

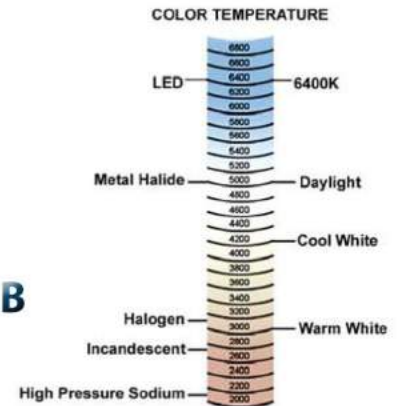

Specifications:

- 14.5" Arm
- 24 Ultra Bright LEDs
- 3 Diopter 3 1/2" Round Glass Lens
- Color: Black
- Power: 5.4W
- Color Temperature: 4369K (Cool White)
- CE/ETL/UL Approved
100V-240V Power Supply
- Master Carton Weight: 2 LBS
- Master Carton Size: 12"(L) x 6 1/2"(W) x 4 1/4"(D)

Features:

- 24 Ultra Bright White LED Light
- 30% Less Current Draw Than Fluorescent Bulbs
- Lightweight Design
- Individual Display Box
- 12 per master carton



MG Electronics - 32 Ranick Road, Hauppauge, NY 11788-4295

Phone: (631) 582-3400

www.mgelectronics.com

Fax: (631) 582-3229

sales@mgelectronics.com



3 DIOPTER LED MAGNIFIER LAMP

The LED360 is the perfect desktop lamp for professionals and home offices.

This unit features a powerful ring of 45 ultra bright LEDs (Light Emitting Diodes) that offer ultra bright white light with 30% less current draw than fluorescent bulbs and as bright as daylight!

The 32" adjustable swing arm design allows freedom of movement in any direction.

The head houses a powerful 5" round 3 Diopter glass magnifying lens.



Model: LED360

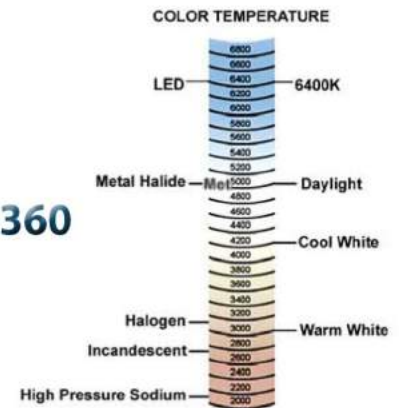

Specifications:

- 32" Spring Balanced Arm: Stays Set in Any Position
- 45 Ultra Bright LEDs
- 3 Diopter 5" Round Glass Lens
- Color: Silver
- Power: 9.4W
- Color Temperature: 4786K (Daylight)
- CE/ETL/UL Approved 100V-240V Power Supply
- Master Carton Weight: 7 LBS
- Master Carton Size: 22"(L) x 14"(W) x 4½"(D)

Features:

- 45 Ultra Bright White LED Light
- 30% Less Current Draw Than Fluorescent Bulbs
- Lightweight Design
- Individual Display Box



MG Electronics - 32 Ranick Road, Hauppauge, NY 11788-4295

Phone: (631) 582-3400
www.mgelectronics.com

Fax: (631) 582-3229
sales@mgelectronics.com



3 DIOPTER LED DESKTOP MAGNIFIER LAMP

The LED600A is the perfect desktop lamp for students, hobbyists, and home offices.

This unit features a powerful ring of 24 ultra bright LEDs (Light Emitting Diodes) that offer ultra bright white light with 30% less current draw than fluorescent bulbs and as bright as daylight!

The 14½" adjustable swing arm design allows freedom of movement in any direction.

The head houses a powerful 3½" round 3 Diopter glass magnifying lens.

The weighted base makes this lamp the perfect desktop accessory.

3X
Diopter



Model: LED600A

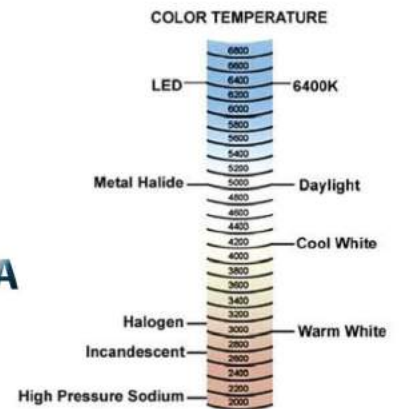

Specifications:

- 14½" Arm
- 24 Ultra Bright LEDs
- 3 Diopter 3½" Round Glass Lens
- 2 lb. Weighted Base
- Color: Black
- Power: 5.4W
- Color Temperature: 4369K (Cool White)
- Replacement Bulb: A14-14
- Individually Boxed / 6 per master carton
- CE/ETL Approved
100V-240V Power Supply

Features:

- 24 Ultra Bright White LED Light
- 30% Less Current Draw Than Fluorescent Bulbs
- Lightweight Design
- Long-Lasting LED Bulbs
(50,000 - 80,000 hours)
- Individual Display Box



MG Electronics - 32 Ranick Road, Hauppauge, NY 11788-4295

Phone: (631) 582-3400
www.mgelectronics.com

Fax: (631) 582-3229
sales@mgelectronics.com



5 DIOPTER LED MAGNIFIER LAMP WITH DIMMER SWITCH

The LED625 is the ideal desktop lamp for home, office or professional medical applications.

This unit features 60 SMD LEDs (Surface-Mount Device; Light Emitting Diodes) that offer ultra bright white light with 30% less current draw than fluorescent bulbs and as bright as daylight! With increased efficiency and longer life than normal LED bulbs, SMD LEDs produce a wider beam angle, resulting in an even dispersion of light and creating the ideal lighting environment.

The 32" adjustable swing arm design allows freedom of movement in any direction.

The round head houses a powerful 5 Diopter 5" magnifying lens (glass).



NEW
for
2018

Model: LED625

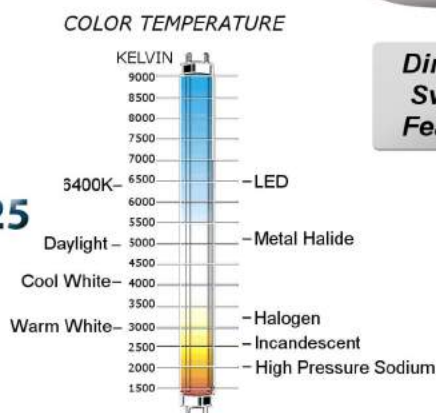

**Dimmer
Switch
Feature!**

Specifications:

- 32" Spring Balanced Arm: Stays Set in Any Position
- 60 Ultra Bright SMD LEDs
- 5 Diopter 5" Round Glass Lens
- Color: White
- Max. Power: 11W
- Max. Lumen: 770
- Color Temperature: 6500K
- GS/RoHS/CE/cUL/UL Approved 100V-120V 60Hz Power Supply
- Master Carton Weight: 7 LBS
- Master Carton Size: 21"(L) x 14½"(W) x 3"(D)

Features:

- Dimmer Switch Feature
- 60 Ultra Bright White SMD LED Light
- 30% Less Current Draw Than Fluorescent Bulbs
- Includes Table Clamp
- Lightweight Design
- Individual Display Box



MG Electronics - 32 Ranick Road, Hauppauge, NY 11788-4295

Phone: (631) 582-3400

www.mgelectronics.com

Fax: (631) 582-3229

sales@mgelectronics.com



5 DIOPTER LED MAGNIFIER LAMP

The LED645 is the ideal desktop lamp for home, office or professional medical applications.

This unit features 90 "Straw Hat" LEDs (Wide Angle Light Emitting Diodes) that offer ultra bright white light with 30% less current draw than fluorescent bulbs and as bright as daylight! With a broader and flatter envelope, "Straw Hat" LEDs produce a very wide radiation angle, resulting in an even dispersion of light and creating the ideal lighting environment.

The 32" adjustable swing arm design allows freedom of movement in any direction.

The round head houses a powerful 5 Diopter 5" magnifying lens (glass).



NEW
for
2018

Model: LED645

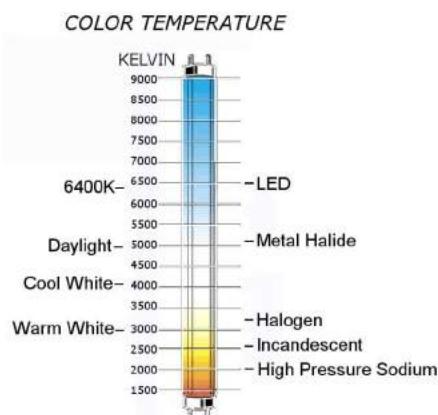

Specifications:

- 32" Spring Balanced Arm: Stays Set in Any Position
- 90 Ultra Bright "Straw Hat" LEDs
- 5 Diopter 5" Round Glass Lens
- Color: White
- Power: 6W
- Lumen: 350
- Color Temperature: 6000-7000K
- GS/RoHS/CE/cUL/UL Approved 100V-120V 60Hz Power Supply
- Lamp Size: 11.02" x 7.4" x 23.62"
- Master Carton Weight: 9 LBS
- Master Carton Size: 24"(L) x 11"(W) x 7½"(D)

Features:

- 90 Ultra Bright White "Straw Hat" LED Light
- 30% Less Current Draw Than Fluorescent Bulbs
- Includes Table Clamp
- Lightweight Design
- Individual Display Box



MG Electronics - 32 Ranick Road, Hauppauge, NY 11788-4295

Phone: (631) 582-3400
www.mgelectronics.com

Fax: (631) 582-3229
sales@mgelectronics.com



5 DIOPTER LED MAGNIFIER LAMP

The LED695 is the ideal desktop lamp for home, office or professional medical applications.

This unit features 56 SMD LEDs (Surface-Mount Device; Light Emitting Diodes) that offer ultra bright white light with 30% less current draw than fluorescent bulbs and as bright as daylight! With increased efficiency and longer life than normal LED bulbs, SMD LEDs produce a wider beam angle, resulting in an even dispersion of light and creating the ideal lighting environment.

The 32" adjustable swing arm design allows freedom of movement in any direction.

The rectangular head houses a powerful 5 Diopter 7.5" x 6.2" magnifying lens (glass).



NEW
for
2018

Model: LED695

COLOR TEMPERATURE

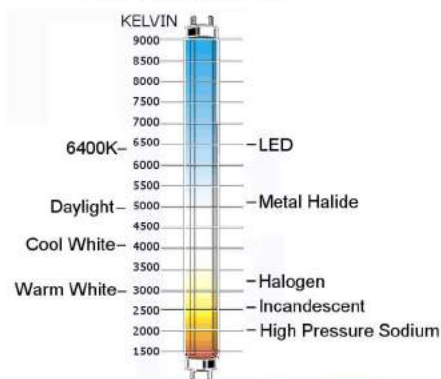

Specifications:

- 32" Spring Balanced Arm: Stays Set in Any Position
- 56 Ultra Bright SMD LEDs
- 5 Diopter Rectangular Glass Lens
- Lens Size: 7.5" x 6.2"
- Color: White
- Power: 9W
- Lumen: 530
- Color Temperature: 6000K-7000K
- GS/RoHS/CE/cUL/UL Approved
- 100V-120V 60Hz Power Supply
- Lamp Size: 9.76" x 5.43" x 22.44"
- Master Carton Weight: 11 LBS
- Master Carton Size: 22½"(L) x 10"(W) x 5½"(D)

Features:

- 56 Ultra Bright White SMD LED Light
- 30% Less Current Draw Than Fluorescent Bulbs
- Includes Table Clamp
- Lightweight Design
- Individual Display Box



MG Electronics - 32 Ranick Road, Hauppauge, NY 11788-4295

Phone: (631) 582-3400

www.mgelectronics.com

Fax: (631) 582-3229

sales@mgelectronics.com



3 DIOPTER LED MAGNIFIER LAMP

The LED850 is the ideal desktop lamp for home, office or professional medical applications.

This unit features 48 ultra bright SMD LEDs (Light Emitting Diodes) that offer ultra bright white light with 30% less current draw than fluorescent bulbs and as bright as daylight!

The LED850 also features 30 UV Blue SMD LEDs.

The 36" adjustable swing arm design allows freedom of movement in any direction.

The head houses a powerful 7" x 5" 3 Diopter glass magnifying lens.

3X
Diopter

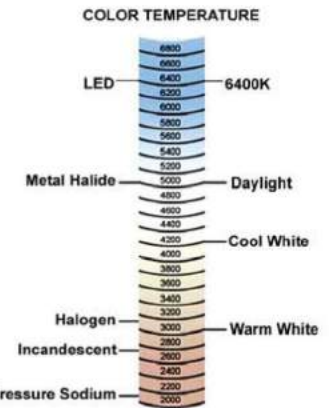
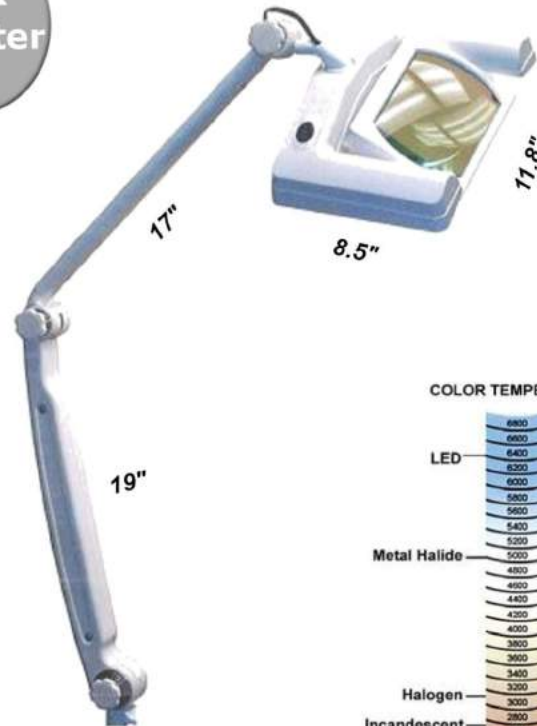

Model: LED850

Specifications:

- 3 Pos Switch - Light / Off / UV
- 36" Spring Balanced Arm: Stays Set in Any Position
- 48 Ultra Bright SMD LEDs
- 30 UV Blue SMD LEDs
- 3 Diopter 7" x 5" Glass Lens
- Color: White
- Power: 9W (LED) and 3W (UV)
- Color Temperature: 6400K (Daylight)
- CE/ETL/UL Approved 100V-240V Power Supply
- Master Carton Weight: 9 LBS
- Master Carton Size: 28½"(L) x 9½"(W) x 7"(D)

Features:

- 48 Ultra Bright White SMD LED Light
- 30% Less Current Draw Than Fluorescent Bulbs
- 30 UV Blue SMD LEDs
- Lightweight Design
- Includes Lens Cover
- Individual Display Box





5 DIOPTER U.V./L.E.D. MAGNIFIER LAMP

The LED1000 is a professional grade U.V. & L.E.D. research and analysis desktop lamp.

This unit features two powerful rings of 102 ultra bright LEDs (Light Emitting Diodes) that offer ultra bright white light with 30% less current draw than fluorescent bulbs and as bright as daylight!

The 36" adjustable swing arm design allows freedom of movement in any direction.

The head houses a powerful 7" round 5 Diopter glass magnifying lens.

**5x
Diopter**

**2 Modes:
White Light
and U.V.**



**Touch
Control**

Model: LED1000

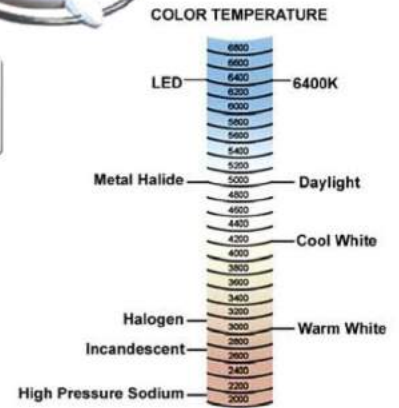

Specifications:

- 36" Spring Balanced Arm: Stays Set in Any Position
- 102 Ultra Bright LEDs
- UV LED
- 5 Diopter 7" Round Glass Lens
- 3 Position Touch Switch
- Color: White
- Power: 4.2W (LED) and 12.6W (UV)
- Color Temperature: 4514K (Daylight)
- CE/ETL Approved 100V-240V Power Supply
- Master Carton Weight: 12½ LBS
- Master Carton Size: 24½"(L) x 21¼"(W) x 3¾"(D)

Features:

- 48 UV LEDs
- 54 Ultra Bright White LED Light
- Touch Control
- 30% Less Current Draw Than Fluorescent Bulbs
- Lightweight Design
- Individual Display Box





CLIP-ON DELUXE MAGNIFIER LAMP

3x
Diopter



Natural Daylight Full Spectrum

LUX-250 Series
Available in White or Black

Model: LUX-250B (Black)
Model: LUX-250W (White)

Magnifier Clip Lamp:

- Compact Size. Ideal for limited workspaces in home or office
- Heavy Duty 2" Clamp to securely clip onto workbench or cubical divider
- Super Bright 'Daylight' 13W energy-saving & long-lasting fluorescent bulb 6400 Kelvin
- High Quality 3½" glass magnifying lens with dust cover
- 16" Gooseneck directs light in any direction
- Ideal for reading, hobbyists, students, model building, coin and stamp collectors, jewelry, eyeglass or watch repair.
- Colors Available: Black, White
- Display Packaged
- ETL Approved



MG Electronics - 32 Ranick Road, Hauppauge, NY 11788-4295

Phone: (631) 582-3400

www.mgelectronics.com

Fax: (631) 582-3229

sales@mgelectronics.com



LUX-300: 3 DIOPTER MAGNIFIER LAMP WITH WEIGHTED BASE

3x
Dioppter

1.75"
Lens

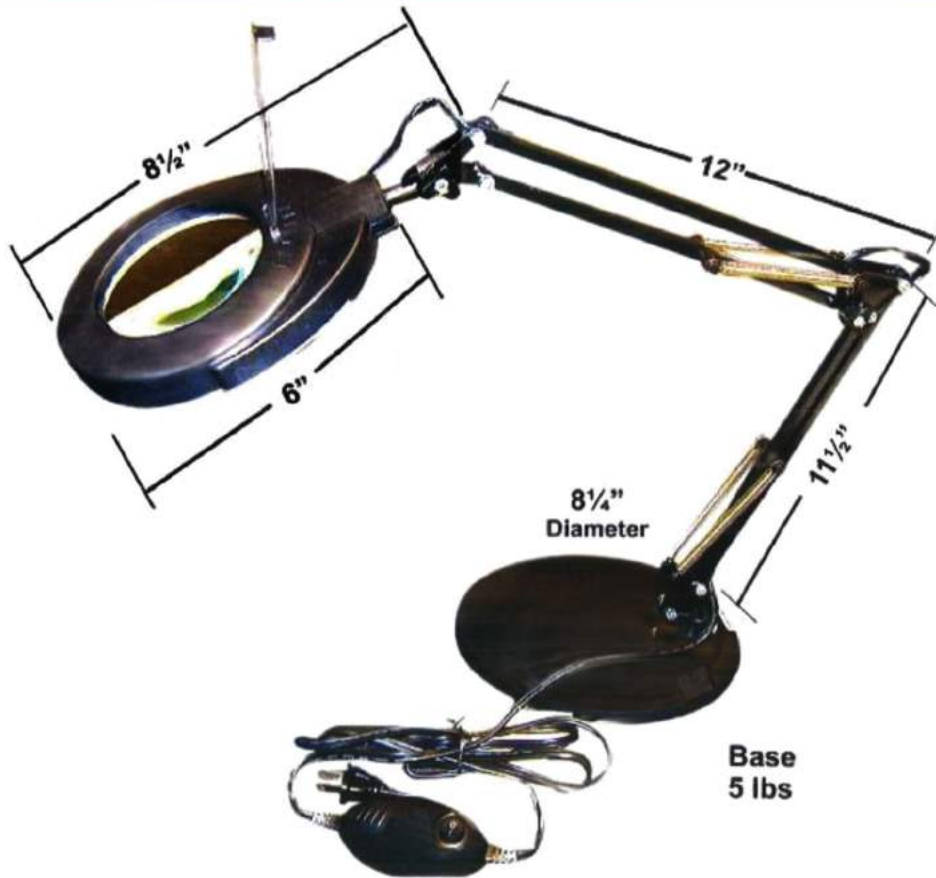

Model: LUX-300

Specifications:

- 120V / 60 Hz 2 Conductor Power Cord
- Supplied with 15W Mini CFL 6400K Energy-Saving Bulb
- 3x Dioppter Lens (1.75" Diameter)
- Assembly: 19.25" x 6" x 18.875"
- Includes dust cover
- White Box
- UL listed
- Color: Black
- Display Packaged
- 4 per carton



MG Electronics - 32 Ranick Road, Hauppauge, NY 11788-4295

Phone: (631) 582-3400

www.mgelectronics.com

Fax: (631) 582-3229

sales@mgelectronics.com



LUX-350: 3 DIOPTER MAGNIFIER LAMP WITH SPINNING WEIGHTED ORGANIZER BASE

3x
Diopter

3.5"
Lens



Model: LUX-350

Specifications:

- 120V / 60 Hz 2 Conductor Power Cord
- Supplied with 15W Mini CFL 6400K Energy Saving Bulb
- 3x Diopter Lens (3.5" Diameter)
- Assembly: 28.625" x 7" x 21.875"
- White Box
- UL listed
- Color: Black
- Display Packaged
- 2 per carton



MG Electronics - 32 Ranick Road, Hauppauge, NY 11788-4295

Phone: (631) 582-3400

www.mgelectronics.com

Fax: (631) 582-3229

sales@mgelectronics.com



DESKTOP MAGNIFIER LAMP

5x
Diopter

LED w/
Weighted Base



Model: LUX-400
LED Magnifier Lamp

Description:

- High Power LED Magnifier Lamp
- Plastic Lens Cover
- 7" 3 Diopter Magnifier Lens
- Measurement Marking on the base
- Replaceable LED Strip
- 30" Extension Arm
- Weighted Base for Desktop use
- Optional Desk Mount Clamp
- UL listed

Specifications:

- Bulb Type: 4 x 3.4W LED
- Watt: 13.6W
- Socket / Switch: ON/OFF
- Color: White
- Individual Display Box
- 2 per carton
- Total Weight: 14 LBS



MG Electronics - 32 Ranick Road, Hauppauge, NY 11788-4295

Phone: (631) 582-3400

www.mgelectronics.com

Fax: (631) 582-3229

sales@mgelectronics.com



DESKTOP MAGNIFIER LAMP

3x
Diopter



Model: LUX-450

Fluorescent Magnifier Lamp

Description:

- 1.75 x - 5" -3 Diopter Lens
- Plastic Lens Cover
- Measurement Marking on the base
- Base for Desktop use
- 14" Vertical Adjustment
- 7" Horizontal Adjustment
- UL listed

Specifications:

- 32W T-9 Fluorescent Bulb
- Color: White
- Individual Display Box
- 4 per carton
- Total Weight: 8 LBS



MG Electronics - 32 Ranick Road, Hauppauge, NY 11788-4295

Phone: (631) 582-3400

www.mgelectronics.com

Fax: (631) 582-3229

sales@mgelectronics.com



3 DIOPTER MAGNIFIER LAMP

3x
Diopter

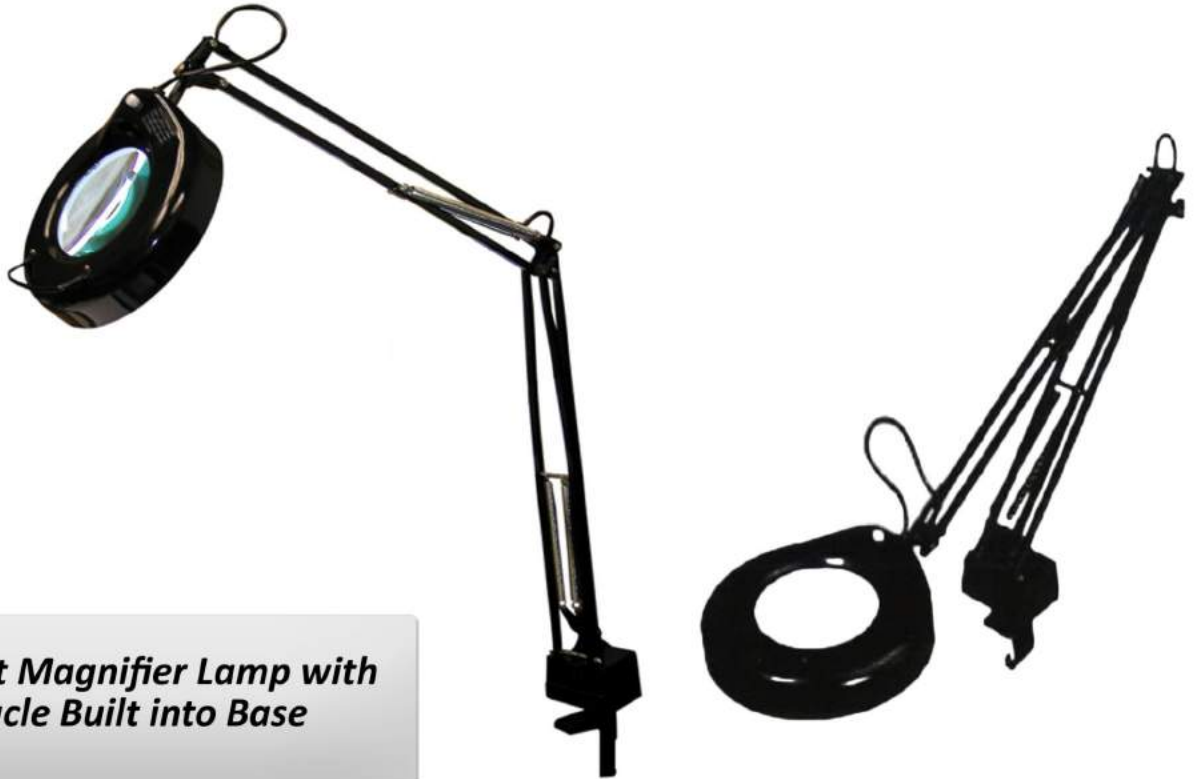

*Fluorescent Magnifier Lamp with
AC Receptacle Built into Base*

Model: LUX-520 (Black)

Model: LUX-520W (White)

Specifications:

- 3 Diopter 5" Round Glass Lens
- 118 - 120V / 60 Hz 3 Conductor Cord
- 45" Extension Arm
- Supplied with 22 Watt Circle Tube
- New Wire Clip Design Permits Easy Installation & Removal of Fluorescent Tube
- AC Receptacle Built into Base
- Available in 2 Colors: Black, White
- Display Packaged
- UL Listed



MG Electronics - 32 Ranick Road, Hauppauge, NY 11788-4295

Phone: (631) 582-3400

www.mgelectronics.com

Fax: (631) 582-3229

sales@mgelectronics.com



5 DIOPTER MAGNIFIER LAMP

5x
Diopter



*Fluorescent Magnifier Lamp with
AC Receptacle Built into Base*

Model: LUX-750

Specifications:

- 5 Diopter 5" Round Glass Lens
- 118 - 120V / 60 Hz 3 Conductor Cord
- 45" Extension Arm
- Supplied with 22 Watt Circle Tube
- New Wire Clip Design Permits Easy Installation & Removal of Fluorescent Tube
- AC Receptacle Built into Base
- Color: Black
- Display Packaged
- UL Listed



MG Electronics - 32 Ranick Road, Hauppauge, NY 11788-4295

Phone: (631) 582-3400

www.mgelectronics.com

Fax: (631) 582-3229

sales@mgelectronics.com



8 DIOPTER MAGNIFIER LAMP

8x
Diopter



*Powerful & Scratch Resistant:
A Must for Professionals and Hobbyists Alike!*

***Fluorescent Magnifier Lamp with
AC Receptacle Built into Base***

Model: LUX-780

Specifications:

- Powerful 8x Diopter *Single Lens*
- 5" Diameter Scratch Resistant Glass Lens
- 118 - 120V / 60 Hz 3 Conductor Cord
- 45" Extension Arm
- Supplied with 22 Watt Circle Tube - Fluorescent Bulb (Model: T-9)
- New Wire Clip Design Permits Easy Installation & Removal of Fluorescent Tube
- AC Receptacle Built into Base
- Color: Black
- Display Packaged
- 4 per Master Carton
- UL Listed



MG Electronics - 32 Ranick Road, Hauppauge, NY 11788-4295

Phone: (631) 582-3400
www.mgelectronics.com

Fax: (631) 582-3229
sales@mgelectronics.com



TRIPLE-LENS MAGNIFIER LAMP

5x
Diopter

5" Lens

8x
Diopter

1.75" Lens

10x
Diopter

1.75" Lens



Model: LUX-900

Specifications:

- 120V / 60 Hz 2 Conductor Power Cord
- Supplied with 13W PL 4 Pin 6400K Fluorescent Bulb
- 5x Diopter Lens (5" Diameter)
- 8x Diopter Lens (1.75" Diameter)
- 10x Diopter Lens (1.75" Diameter)
- Assembly: 30.5" x 9.375" x 22.75"
- White Box
- Color: Black
- 1 per Carton
- UL Listed



MG Electronics - 32 Ranick Road, Hauppauge, NY 11788-4295

Phone: (631) 582-3400

Fax: (631) 582-3229

www.mgelectronics.com

sales@mgelectronics.com



MG Pricing

Magnifier Lamp and Replacement Bulb Price List

MG Electronics
32 Ranick Road
Hauppauge, NY11788

Phone: (631) 582-3400
Fax: (631) 582-3229
Website: www.mgelectronics.com
Email: sales@mgelectronics.com

	Lamp Model	Lens	Color	Per Carton	Lamp Price	Bulb Model	Bulb Carton Quantity	Bulb Price	
LED LAMPS	LED-125	3 DIOPTER	WHITE	1	\$46.95	NA			
	LED-128	8 DIOPTER	WHITE	1	\$52.95	NA			
	LED-172	3 DIOPTER	WHITE	1	\$68.95	NA			
	LED-210	3/5 DIOPTER	WHITE	1	\$49.95	NA			
	LED-250B	3 DIOPTER	BLACK	12	\$25.25	NA			
	LED-360	3 DIOPTER	WHITE	1	\$50.95	NA			
	LED-600A	3 DIOPTER	BLACK	6	\$27.95	A14-14	50	\$12.00 each	
	LED-625	5 DIOPTER	WHITE	1	\$48.95	NA			
	LED-645	5 DIOPTER	WHITE	1	\$48.95	NA			
	LED-695	5 DIOPTER	WHITE	1	\$71.95	NA			
	LED-850	3 DIOPTER	WHITE	1	\$77.95	NA			
	LED-1000	5 DIOPTER	WHITE	1	\$145.00	NA			
	FLUORESCENT LAMPS	LUX-250B	3 DIOPTER	BLACK	8	\$15.00	T4-12W	100	\$5.75 each
		LUX-250W	3 DIOPTER	WHITE	8	\$15.00	T4-12W	100	\$5.75 each
LUX-300		3 DIOPTER	BLACK TABLETOP	1	\$19.00	T4-12W	100	\$5.75 each	
LUX-350		3 DIOPTER	BLACK TABLETOP	1	\$25.00	CFL-13W	100	\$5.95 each	
LUX-400		3 DIOPTER	WHITE LED	1	\$83.25	NA			
LUX-450		3 DIOPTER	WHITE TABLETOP	1	\$36.95	T9-22W	20	\$5.75 each	
LUX-520		3 DIOPTER	BLACK	1	\$36.95	T9-22W	20	\$5.75 each	
LUX-520W		3 DIOPTER	WHITE	1	\$36.95	T9-22W	20	\$5.75 each	
LUX-750		5 DIOPTER	BLACK	1	\$43.95	T9-22W	20	\$5.75 each	
LUX-780		8 DIOPTER	BLACK	1	\$49.75	T9-22W	20	\$5.75 each	
LUX-900		5/8/10 DIOPTER	BLACK	1	\$27.75	PL-13W	50	\$4.50 each	

Diopter	Magnification
3	1.75
5	2.25
8	3
10	3.5