

BL-DC Fans for Commercial Vehicles

Product Catalogue 2019-10

ebmpapst

the engineer's choice



BL-DC Fans for Commercial Vehicles

Our BL-DC axial fans and BL-DC dual centrifugal fans with housing are ground breakers in the field of commercial vehicle air conditioning. They not only meet the increased demands for comfort, e.g. in buses but also work wear-free for over 40.000 operating hours as they are brushless. No additional maintenance, no additional servicing. This corresponds to the usual reliability expected from ebm-papst. Data is subject to change without notice at ebm-papst discretion.

Benefits and characteristics at a glance

- over 40.000 operating hours
- variable speed control
- high efficiency
- low sound emission thanks to aerodynamically optimized impellers
- increased reliability due to the electronics' high integration density
- can be retrofitted into existing systems
- compliance with the most stringent EMC requirements
- high moisture protection class
- temperature and power derating
- extended temperature range
- long-life ball bearings



BL-DC Fans for *Commercial Vehicles*

ebmpapst

the engineer's choice

	Page		Page
Information	4	About ebm-papst	4
		Ideas for changing technology in commercial vehicles	6
		Product overview	8
BL-DC Fans for Commercial Vehicles	10	BL-DC dual centrifugal fans with housing "Premium" Ø 097 (dual-intake)	10
		BL-DC dual centrifugal fans with housing "Basic" Ø 097 (dual-intake)	20
		BL-DC axial fans "Premium & Power" Ø 250 - Ø 385	30
		BL-DC axial fans "Heavy Duty" Ø 300	52
		BL-DC axial fans "Basic" Ø 300	62
		BL-DC centrifugal fan vorward curved Ø 146 (without housing, single-intake)	68
		BL-DC centrifugal fan - RadiCal backward curved Ø 220 - Ø 280	74
Accessories	88	Cables	90
		Guard grille	92
		Inlet rings	94
Technology	96	Connection diagrams	98
		Technical parameters & scope	114
ebm-papst agents	120		120

Information

Fans for Commercial Vehicles - Edition 2019-10

Accessories

Technology

Agents

About ebm-papst

ebm-papst is a leader in ventilation and drive engineering technology and a much sought-after engineering partner in many industries. With around 20.000 different products, we have the perfect solution for practically every requirement. We have placed the highest emphasis on economy and ecology for many years.

We believe the consistent further development of our highly-efficient GreenTech EC technology provides our customers with the best opportunities for the future in industrial digitization. With GreenIntelligence, ebm-papst already offers intelligent networked complete solutions that are unique anywhere in the world today and that secure our customers a decisive advantage.

Six reasons why we are your ideal partner:

Our systems expertise.

Of course you always want the best solution for every project. To get it, you need to consider the ventilation and drive engineering aspects as a whole.

And that is precisely what we do...with **motor technology** that sets standards, highly sophisticated **electronics** and **aerodynamically** optimized designs – all from a single source and perfectly matched. These system solutions release unique synergies worldwide. What's more: they save you a lot of work. Using them means you can concentrate on your core business.

ebm-papst's spirit of invention.

In addition to offering a wide range of products, we are able to develop customized solutions for you at any time. At our three German locations in Mulfingen, Landshut and St. Georgen, a diverse team of 600 engineers and technicians is ready to work to your specifications.

Just get in touch with us to discuss your latest project.

Our cutting-edge technology.

ebm-papst is not only a pioneer in developing highly efficient EC technology. We were also quick to recognize the potential of digitalization.

This means we are now able to provide solutions that combine maximum energy efficiency with all the advantages of IoT and digital connectivity.

Proximity to our customers.

ebm-papst has 25 worldwide production facilities, including those in Germany, China, the USA, plus 49 sales offices with an extensive network of sales representatives.

You always have a local contact who speaks your language and is familiar with your market.

Our quality standards.

Of course you can rely on the top quality of our products. After all, we employ an uncompromising quality management system at every stage of the process.

This is documented by our certification in accordance with the DIN EN ISO 9001 and DIN EN ISO 14001 international standards, and the TS declaration of conformity.

Sustainability as a way of life.

Assuming responsibility – for the environment, our employees and society – is an integral part of our corporate philosophy. That is why we develop products designed for maximum environmental compatibility and produce them using processes that preserve resources.

We support environmental awareness among our junior staff and are actively involved in sporting, cultural and educational activities.

All of which makes us a better partner.

The story of our success to market and technology pioneer

- 1963** Founding of **Elektrobau Mulfingen GmbH & Co. KG** by Gerhard Sturm and Heinz Ziehl.
- 1965** First tubeaxial fan developed in EC/DC technology.
- 1966** ebm-papst's success takes off with the new 68 motor.
- 1972** The first ebm foreign subsidiary is established in Sweden.
- 1988** Gerhard Sturm is awarded the Federal Cross of Merit.
- 1990** The sixty-millionth external-rotor fan is produced.
- 1992** Acquisition of **PAPST Motoren GmbH** in St. Georgen.
- 1997** Buyout of the **Landshut** (mvl) plant.
- 1998** Development of first fans with integrated electronics.
- 2003** Change of name to **ebm-papst**.
- 2008** The **HyBlade**® range of fans sets new efficiency standards.
- 2010** **GreenTech** – our sign for energy efficiency and resource preservation.
- 2011** **RadiCal** defines a new standard for EC centrifugal fans.
- 2013** ebm-papst takes over the gearbox specialist Zeitlauf and wins the **German Sustainability Award**.
- 2014** Team partnership with Mercedes-AMG Petronas Formula 1 team.
- 2015** **RadiPac** pushes the limits of efficiency.
- 2016** **AxiBlade** sets new standards in ventilation, refrigeration and air-conditioning.
- 2017** Factory expansions Germany: logistics center in Hollenbach and production unit in Hagenmoos.
- 2018** **GreenIntelligence** becomes the new byword for smart complete solutions.

Ideas for changing technology in commercial vehicles

Climate comfort in a commercial vehicle is anything but a question of convenience.

Both the transportation of people in buses and coaches, as well truck journeys which are as stress and fatigue-free as possible, place high demands on vehicle technology; predominantly air conditioning, ventilation, and heating.

For many years, major bus and truck manufacturers have been installing air conditioners with brushless and wear-free centrifugal blowers and axial fans from ebm-papst. In particular, these products are also now widely used in the air conditioning and ventilation systems for the cabs in trucks, tractors and construction machinery, as well as in transport refrigeration systems.

A number of air conditioning manufacturers rely on our experience and outstanding expertise in the core competencies of engine development, aerodynamics, and electronics.



Counteracting high demands with new technologies:

In modern commercial vehicles, BL-DC technology has now become standard. Our BL-DC axial fans and BL-DC dual centrifugal fans of the newest generation housing set a precedent in global commercial vehicle air conditioning. Our BL-DC fans have even been able to demonstrate their clear superiority in hot countries and tropical regions, where they have also proven their worth. But it is not just in the field of air conditioning products where customers are relying on ebm-papst products: Our BL-DC fans are being used in an increasing number of heavy-duty applications such as vehicle engines. After all, dirt from the road, fine particles and chemically aggressive contamination cannot stop our heavy-duty fans.

Fans and blowers:

for commercial vehicle air conditioning and cooling of individual components.



However, ebm-papst has even more to offer:

If you are unable to find a solution amongst our products, speak to us. As a competent consultant and practical implementer, we will certainly be able to find you a solution thanks to our in-depth knowledge from many applications.





In comparison:

In brush motors from various manufacturers, the commutator assumes the role of current distribution to the coils. The commutator consists of copper fins embedded in an insulating compound. Mechanical springs push the integrated carbon brushes to the commutator. These two rubbing mechanical components are the weak spot of conventional DC motors. After around 5.000 operating hours, the carbon brushes are run down and the commutator is worn. As a result, the entire blower must be replaced. In addition, it is only possible to regulate speed via external electronics.

The brushless DC motors from ebm-papst are completely different. Here, an electronic controller directly integrated in the motor has the task of distributing current. No brushes means no wearing parts. This increases the service life of these motors to more than 40.000 hours. The user not only saves money in terms of replacement parts and repair costs, he also avoids unproductive downtimes and a possible loss of image. BL-DC motors are energy efficient, because the integrated electronics with variable speed control only draw the energy actually required from the on-board network. In the commercial vehicle sector, it is also crucial that fans withstand constantly changing environmental influences.



Standard products would only provide unsatisfactory results here. For this reason, transportation products from ebm-papst are also reliably protected against load dumping, reverse polarity, shock and vibration, as well as damage from moisture and dirt penetration across a wide temperature range.



This also requires special efforts in terms of the selection of materials and testing of products. With the help of real-world extreme tests that we have defined in collaboration with leading OEMs (e.g., salt spray, vibration and temperature cycling tests), we are able to ensure the performance of the fans.



Apart from the considerably longer service life, our intelligent BL-DC fans provide advanced control and regulation possibilities. The functionality of the fans can be checked via a diagnostic output at any time. Furthermore, these display excellent electromagnetic compatibility traits and operate extremely quietly.

Product overview

BL-DC fans for commercial vehicles

BL-DC dual centrifugal fans with housing "Premium" (dual-intake)

Ø	Nominal voltage VDC	Air performance m³/h	Dual centrifugal fans forward curved with housing		on Page
			Type	Part number	
097	26	1200	VFM0097XUPCS	K3G097AP4601	12
	26	1575	VFM0097XUPCS	K3G097AS8207	
	26	1125	VFM0097XUPCS	K3G097BP4601	

BL-DC dual centrifugal fans with housing "Basic" (dual-intake)

Ø	Nominal voltage VDC	Air performance m³/h	Dual centrifugal fans forward curved with housing		on Page
			Type	Part number	
097	26	1290	VFD0097XUNES	K3G097AK3465	22
	26	1110	VFD0097XUNES	K3G097BK3465	

BL-DC axial fans "Premium & Power"

Ø	Nominal voltage VDC	Air performance m³/h	Axial fans		on Page
			Type	Part number	
250	26	1240	VWS0250XUNBS	W3G250EC2401	32
	26	1815	VWS0250XUNBS	W3G250EC2811	
300	13	2610	VWS0300XUPCS	W3G300BV1241	36
	26	2510	VWS0300XUPCS	W3G300ME4701	
	26	3085	VWS0300XUPCS	W3G300ME4811	
385	13	4110	VWS0385XUPES	W3G385CT5361	44
	26	4375	VWS0385XUPES	W3G385CT6521	
	26	3425	VWS0385XUPCS	W3G385BV4401	
	26	3425	VWS0385XUPCS	W3G385BS4401	

Subject to technical changes.

BL-DC axial fans "Heavy Duty"

Ø	Nominal voltage VDC	Air performance m³/h	Axial fans 		on Page
			Type	Part number	
300	26	3160	VWS0300XUPCS	W3G300QX2523	54
	26	3685	VWS0300XUPCS	W3G300QX2640	
	26	3315	VWS0300XUPCS	W3G300QY2523	
	26	3685	VWS0300XUPCS	W3G300QY2640	

BL-DC axial fans "Basic"

Ø	Nominal voltage VDC	Air performance m³/h	Axial fans 		on Page
			Type	Part number	
300	13	2340	VWT0300XUNES	W1G300EC1220	64
	26	2840	VWT0300XUNES	W1G300EC2414	

BL-DC centrifugal fans forward curved without housing (*single-intake*)

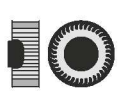
Ø	Nominal voltage VDC	Air performance m³/h	Centrifugal fans forward curved without housing 		on Page
			Type	Part number	
146	26	815	VF50146XUPCS	R3G146EC5001	70

BL-DC centrifugal fans - RadiCal backward curved

Ø	Nominal voltage VDC	Air performance m³/h	Centrifugal fans - RadiCal backward curved 		on Page
			Type	Part number	
220	12	990	VBS0220RUNCS	R1G220RD6103	76
	24	1125	VBS0220RUNCS	R1G220RD1003	
250	12	1095	VBS0250RUNES	R1G250RC7703	80
	24	1375	VBS0250RUNES	R1G250RC8703	
280	26	2740	VBS0280RUPES	R3G280RU2681	84
	26	3345	VBS0280RUPES	R3G280RU6582	



BL-DC dual centrifugal fans with housing "Premium" Ø 097

ebmpapst

the engineer's choice

	Page
Ø 097	12

BL-DC dual centrifugal fans

forward curved with housing, for commercial vehicle applications, Ø 097 mm



Material/surface

- Scroll housing: PP plastic
- Impeller: PA plastic

Mechanical data

- Direction of rotation: Clockwise viewed toward rotor
- Mode: Continuous operation (S1)
- Mounting: Maintenance-free ball bearings, sealed

Standards and approvals

- Approvals: EAC, E1 in preparation

on Page 14	Drawings
on Page 88	Accessories
on Page 98	Connection diagrams and technical features
on Page 114	Technical parameters & scope
More at	www.ebmpapst.com

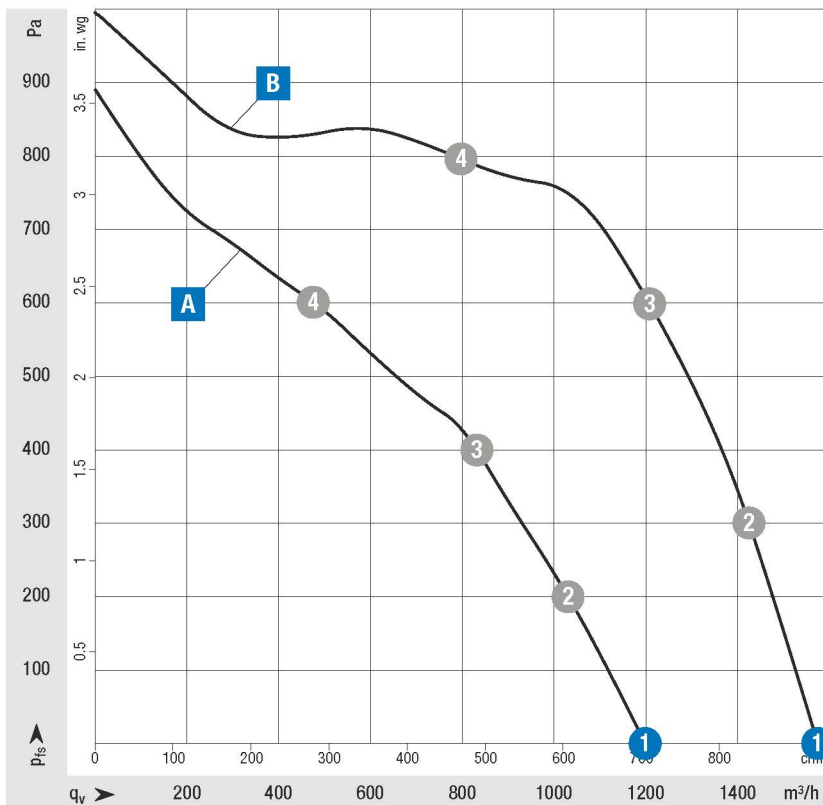

Measuring requirements

Air performance measured according to: ISO 5801, installation category A, with ebmpapst scroll housing without contact protection. Intake-side sound level: L_{pA} according to 13347, L_{pA} measured at 1 m distance from fan axis. The values given are only applicable under the specified measuring conditions and may differ depending on the installation conditions. In the event of deviation from the standard configuration, the parameters must be checked in installed condition.

Curve	Operating point	Nominal voltage	Speed n	Max. Input power P _{ed}	Max. Input current I	Sound power level L _{WA}	Installation position	Perm. ambient temp.	Degree of protection	Insulation class	Conn. diagram
		VDC									
Nominal voltage range 16-32 V DC											
A	1	26	3500	320	12,2	81	Any	-40..+85 (above +75 °C with power derating)	Motor: IP 24 KM Electronics: IP 66/69 K (mating conn. installed)	B	TR1)
	2	26	3780	284	10,9	78					
	3	26	4100	246	9,43	77					
	4	26	4630	183	7,03	77					
B	1	26	4680	740	28,0	88	Any	-40..+85 (above +75 °C with power derating)	Motor: IP 24 KM Electronics: IP 66/69 K (mating conn. installed)	B	TR2)
	2	26	5025	740	28,0	87					
	3	26	5380	659	25,3	85					
	4	26	5500	441	16,9	84					

Values set in blue are nominal data at operating point with maximum load.

Subject to change

Curve			
	BL-DC dual centrifugal fans with housing		
	Type	Part number	Weight
			kg
A	VFM0097XUPCS	K3G097AP4601	2,00
B	VFM0097XUPCS	K3G097AS8207	2,00

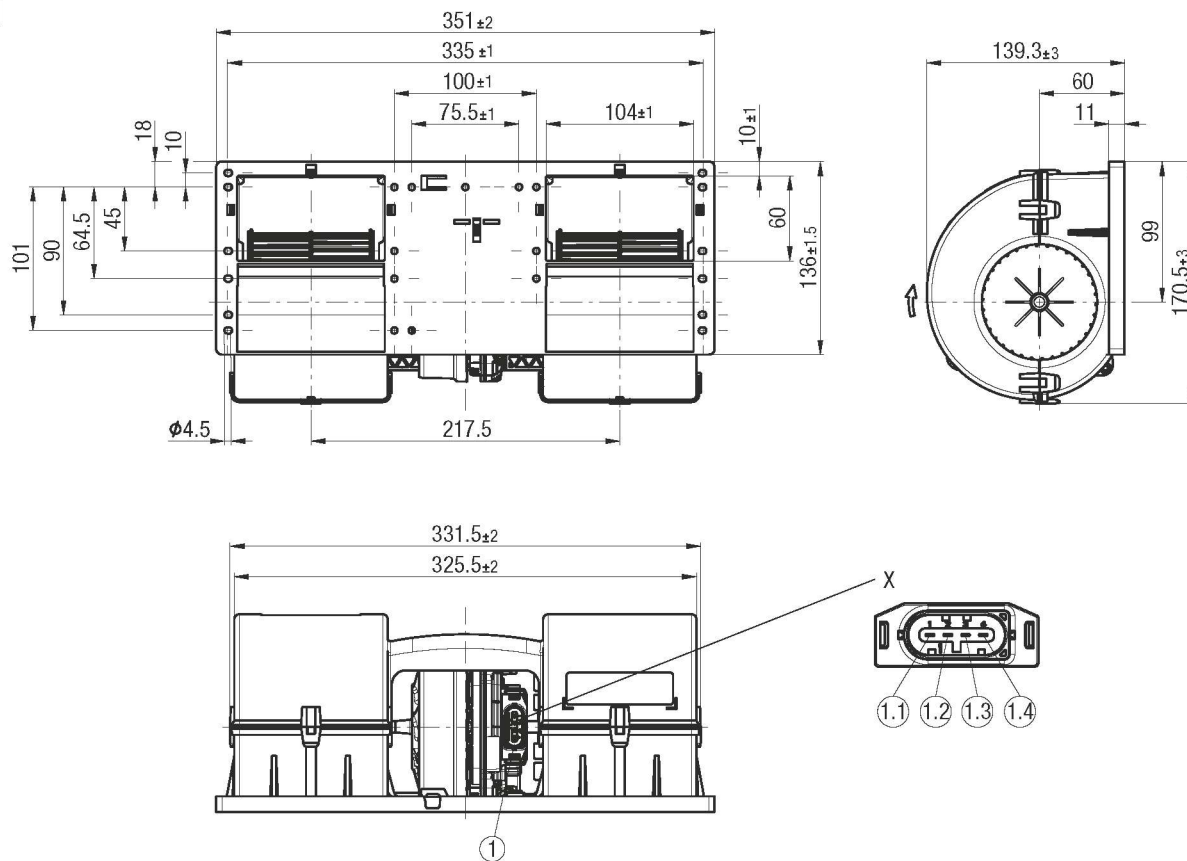

① 4-pole plug, pluggable with cable from accessories:

Accessory part: Cable (460 mm) with mating connector, part no. 02040-4-1021 not included in scope of delivery, 4-pole mating connector TE 1-1718628-1, 2x plug contact TE 1-968855-1, 2x plug contact TE 1-968857-1, 2x seal TE 828905-1, 2x seal TE 828904-1

Pin assignment: (see connection diagram)

- ①.1 Diagnostic output
- ①.2 PWM/LIN
- ①.3 + UB
- ①.4 GND

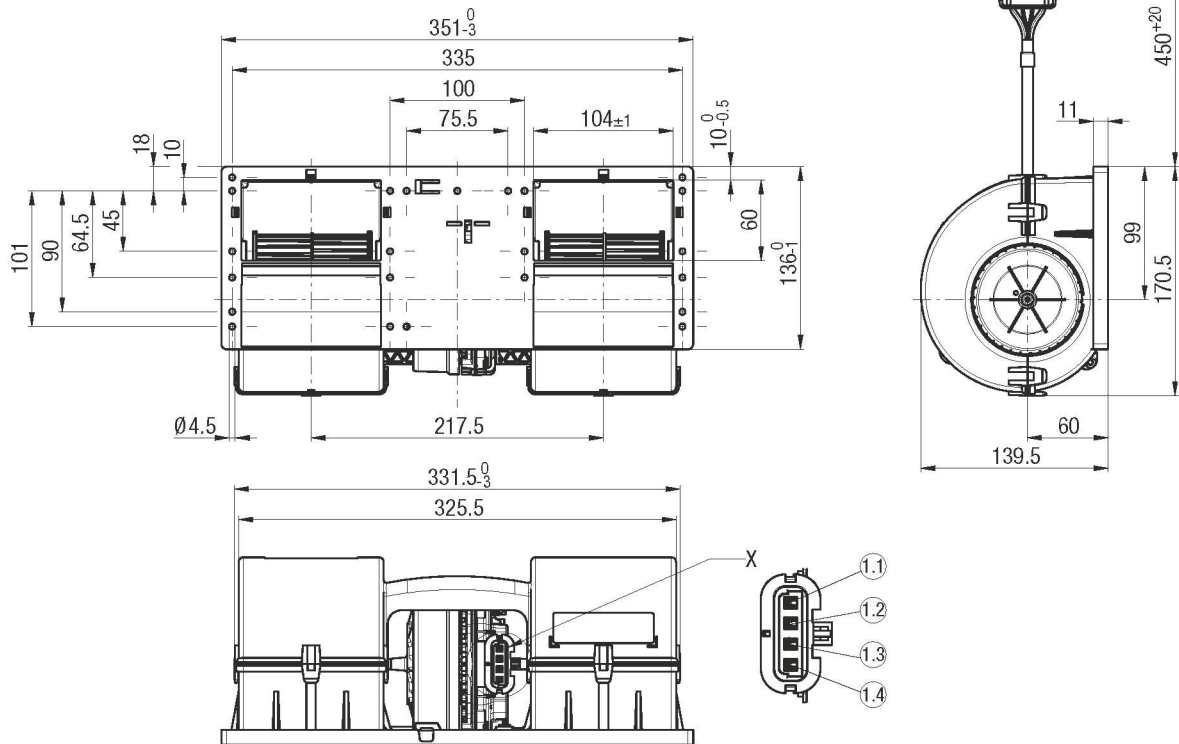

① Cable FLRYW 2x 4 mm², 2x 0,75 mm²:

4-pole connector housing Aptiv 12129600, 2x flat plug Aptiv 12048254, 2x flat plug Aptiv 12048159, 2x seal Aptiv 15324981, 2x seal Aptiv 15324985, 4-pole mating connector Aptiv 12129565, TPA (Terminal Position Assurance) 15300016, 2x flat plug Aptiv 12077413, 2x flat plug Aptiv 12077411, 2x seal Aptiv 15324981, 2x seal Aptiv 15324985

Pin assignment: (see connection diagram)

- ①.1 + UB
- ①.2 PWM/LIN
- ①.3 Diagnostic output
- ①.4 GND

BL-DC dual centrifugal fans

forward curved with housing, for commercial vehicle applications, Ø 097 mm

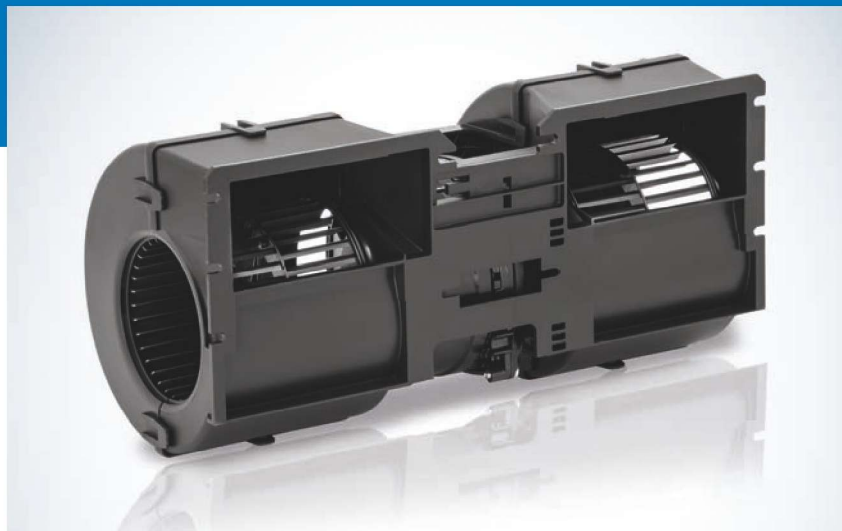

Material/surface

- Scroll housing: PP plastic
- Impeller: PA plastic

Mechanical data

- Direction of rotation: Clockwise viewed toward rotor
- Mode: Continuous operation (S1)
- Mounting: Maintenance-free ball bearings, sealed

Standards and approvals

- Approvals: E1 in preparation

on Page 18	Drawings
on Page 88	Accessories
on Page 98	Connection diagrams and technical features
on Page 114	Technical parameters & scope
More at	www.ebmpapst.com

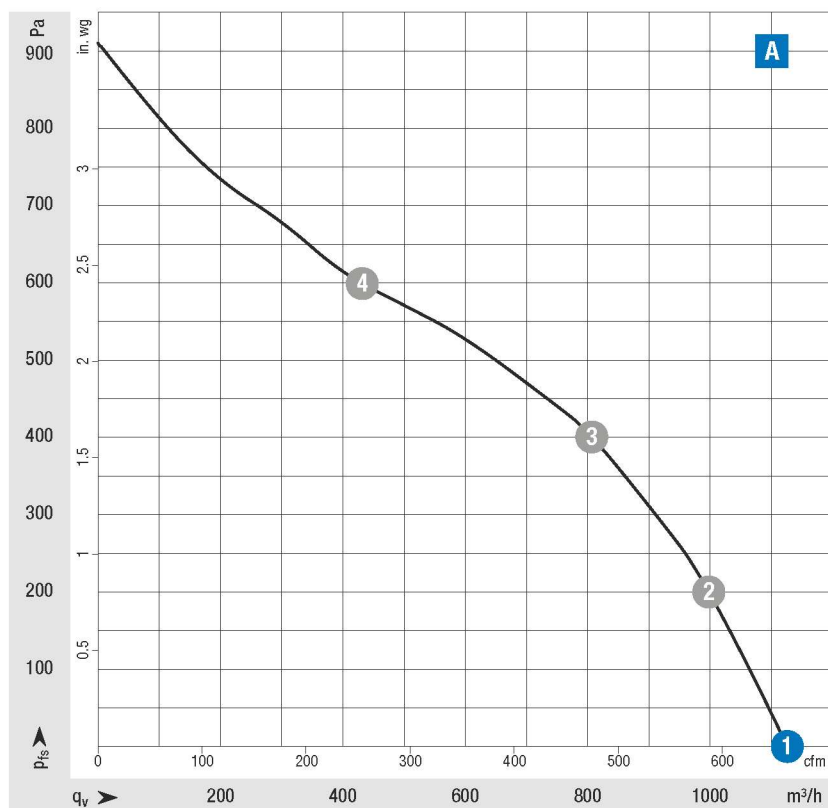

Measuring requirements

Air performance measured according to: ISO 5801, installation category A, with ebmpapst scroll housing without contact protection. Intake-side sound level: L_{pA} according to 13347, L_{pA} measured at 1 m distance from fan axis. The values given are only applicable under the specified measuring conditions and may differ depending on the installation conditions. In the event of deviation from the standard configuration, the parameters must be checked in installed condition.

Curve	Operating point	Nominal voltage		Max. Input power P _{ed}	Max. Input current I	Sound power level L _{WA}	Installation position	Perm. ambient temp.	Degree of protection	Insulation class	Conn. diagram
		VDC	rpm								
Nominal voltage range 16-32 V DC											
A	1	26	3600	310	11,8	79	Any	-40...+85 (above +75 °C with power derating)	Motor: IP 24 KM Electronics: IP 66/69 K (mating conn. installed)	B	TR1)
	2	26	3825	278	10,7	77					
	3	26	4160	243	9,34	76					
	4	26	4690	168	6,47	77					

Values set in blue are nominal data at operating point with maximum load.

Subject to change



Curve	BL-DC dual centrifugal fans with housing		
	Type	Part number	Weight
A	VFM0097XUPCS	K3G097BP4601	2,00 kg

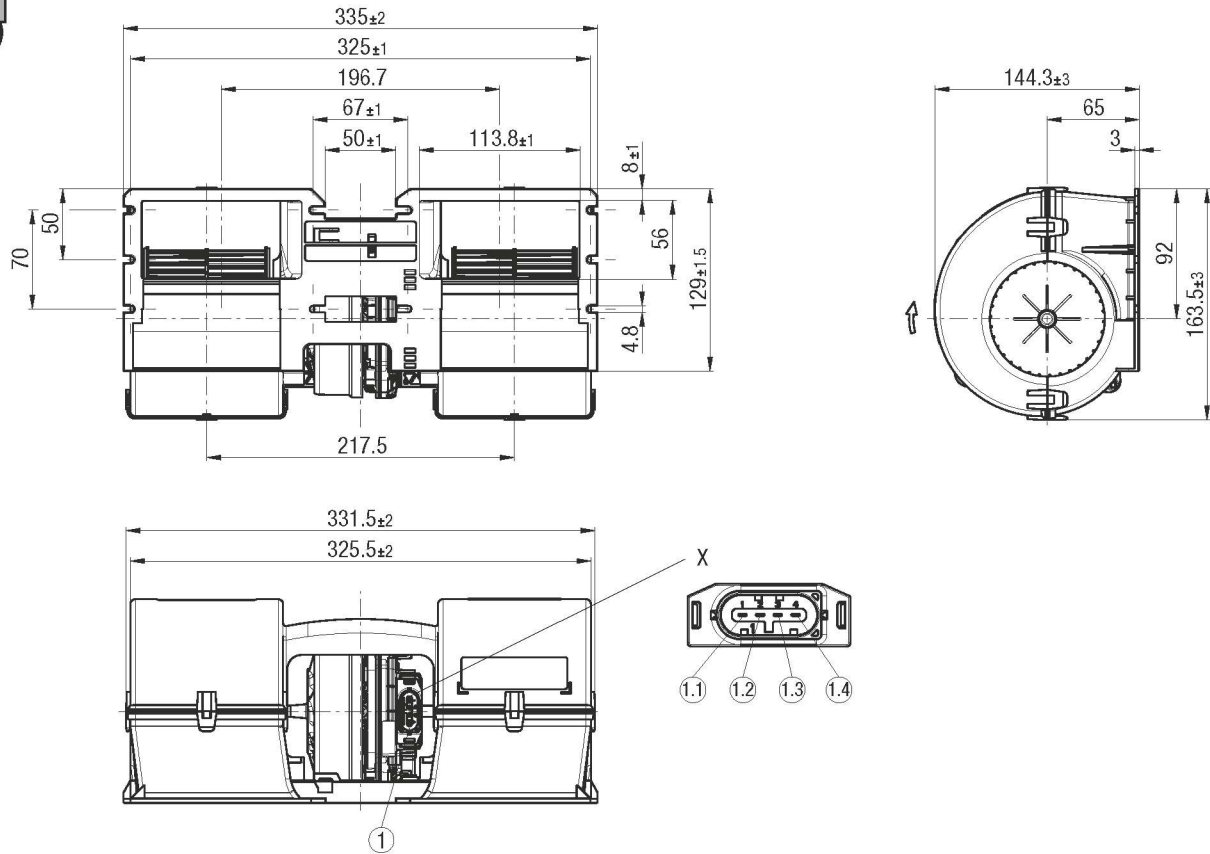

① 4-pole plug, pluggable with cable from accessories:

Accessory part: Cable (460 mm) with mating connector, part no. 02040-4-1021 not included in scope of delivery 4-pole mating connector TE 1-1718628-1, 2x plug contact TE 1-968855-1, 2x plug contact TE 1-968857-1, 2x seal TE 828905-1, 2x seal TE 828904-1

Pin assignment: (see connection diagram)

- ①.1 Diagnostic output
- ①.2 PWM/LIN
- ①.3 + UB
- ①.4 GND



BL-DC dual centrifugal fans with housing "Basic" Ø 097

ebmpapst

the engineer's choice

	Page
Ø 097	22

BL-DC dual centrifugal fans

forward curved with housing, for commercial vehicle applications, Ø 097 mm



Material/surface

- Scroll housing: PP plastic, black
- Impeller: PA plastic (UL94 HB), black

Mechanical data

- Direction of rotation: Clockwise viewed toward rotor
- Mode: Continuous operation (S1)
- Mounting: Maintenance-free ball bearings

Standards and approvals

- Approvals: EAC, E1

on Page 24	Drawings
on Page 88	Accessories
on Page 98	Connection diagrams and technical features
on Page 114	Technical parameters & scope
More at	www.ebmpapst.com

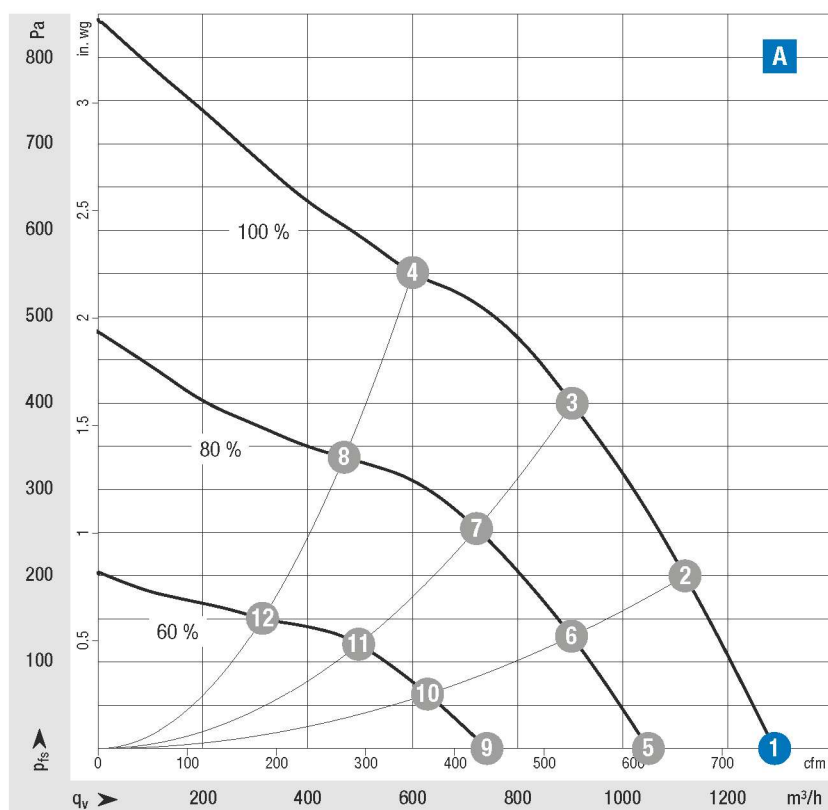

Measuring requirements

Air performance measured according to: ISO 5801, installation category A, with ebmpapst scroll housing without contact protection. Intake-side sound level: L_{wA} according to 13347, L_{wA} measured at 1 m distance from fan axis. The values given are only applicable under the specified measuring conditions and may differ depending on the installation conditions. In the event of deviation from the standard configuration, the parameters must be checked in installed condition.

Curve	Operating point	Nominal voltage		Speed n	Max. Input power P _{ed}	Max. Input current I	Sound power level L _{WA}	Installation position	Perm. ambient temp.	Degree of protection	Insulation class	Conn. diagram
		VDC	rpm									
Nominal voltage range 16-32 V DC												
A	1	26	3830	394	15,2	79	Any	-40..+85 (above +75 °C with power derating)	IP 24 KM (without connector)	B	TR3)	
	2	26	4075	353	13,5	76						
	3	26	4320	294	11,3	75						
	4	26	4670	233	8,9	75						
	5	26	3145	215	8,3	75						
	6	26	3315	188	7,2	72						
	7	26	3470	155	6,0	70						
	8	26	3670	118	4,5	69						
	9	26	2245	79	3,1	66						
	10	26	2325	68	2,6	66						
	11	26	2415	56	2,2	61						
	12	26	2490	42	1,6	60						

Values set in blue are nominal data at operating point with maximum load.

Subject to change

Curve			
	BL-DC dual centrifugal fans with housing		
	Type	Part number	Weight
A	VFD0097XUNES	K3G097AK3465	2,10 kg

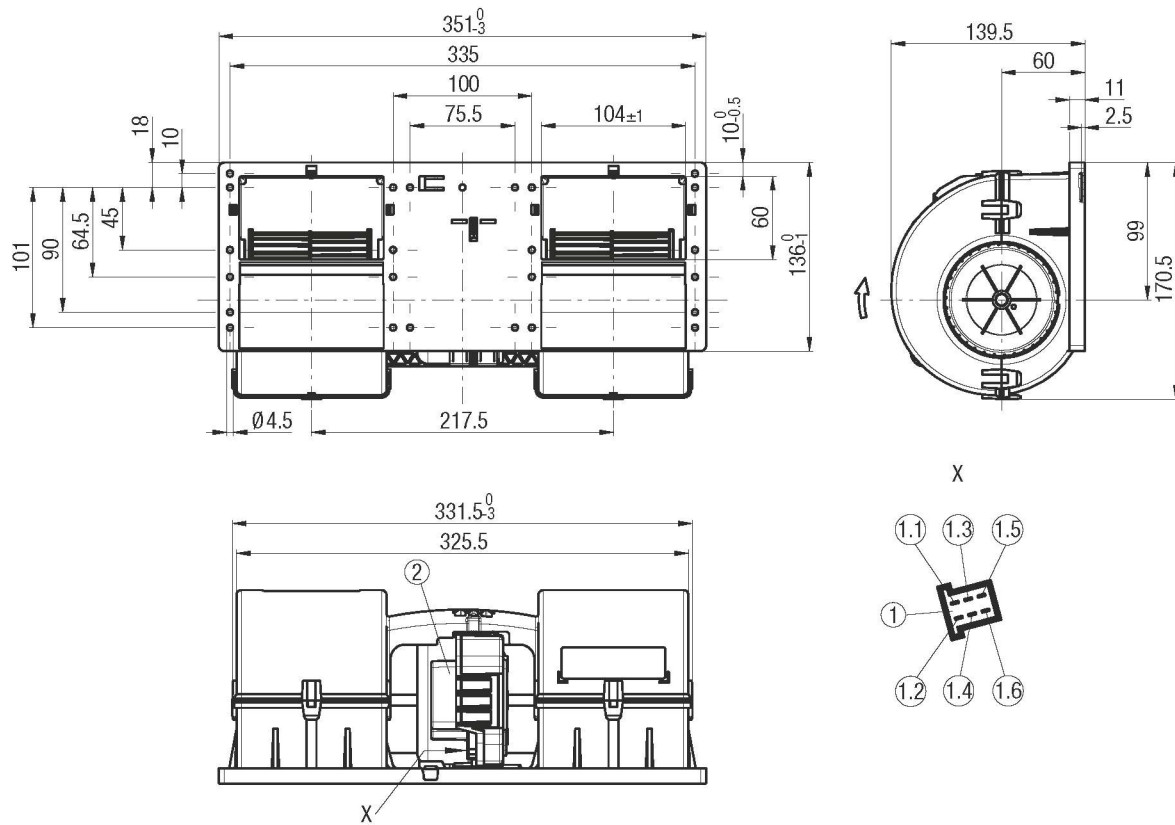

① 6-pole header TE Junior Power Timer WE_9901118:

Accessory part: Cable (460 mm) with mating connector, part no. 02001-4-1021 not included in scope of delivery, 6-pole mating connector TE 929504-2, 4x plug contact TE 927771-1, 2x plug contact TE 927768-1

② Electronics cover blue (RAL 5015)

Pin assignment: (see connection diagram)

- ①.1 + UB
- ①.2 GND
- ①.3 PWM/LIN, 100% speed
- ①.4 80% speed
- ①.5 60% speed
- ①.6 Not used / no function

BL-DC dual centrifugal fans

forward curved with housing, for commercial vehicle applications, $\varnothing 097$ mm



Material/surface

- Scroll housing: PP plastic, black
- Impeller: PA plastic (UL94 HB), black

Mechanical data

- Direction of rotation: Clockwise viewed toward rotor
- Mode: Continuous operation (S1)
- Mounting: Maintenance-free ball bearings

Standards and approvals

- Approvals: EAC, E1

on Page 28	Drawings
on Page 88	Accessories
on Page 98	Connection diagrams and technical features
on Page 114	Technical parameters & scope
More at	www.ebmpapst.com

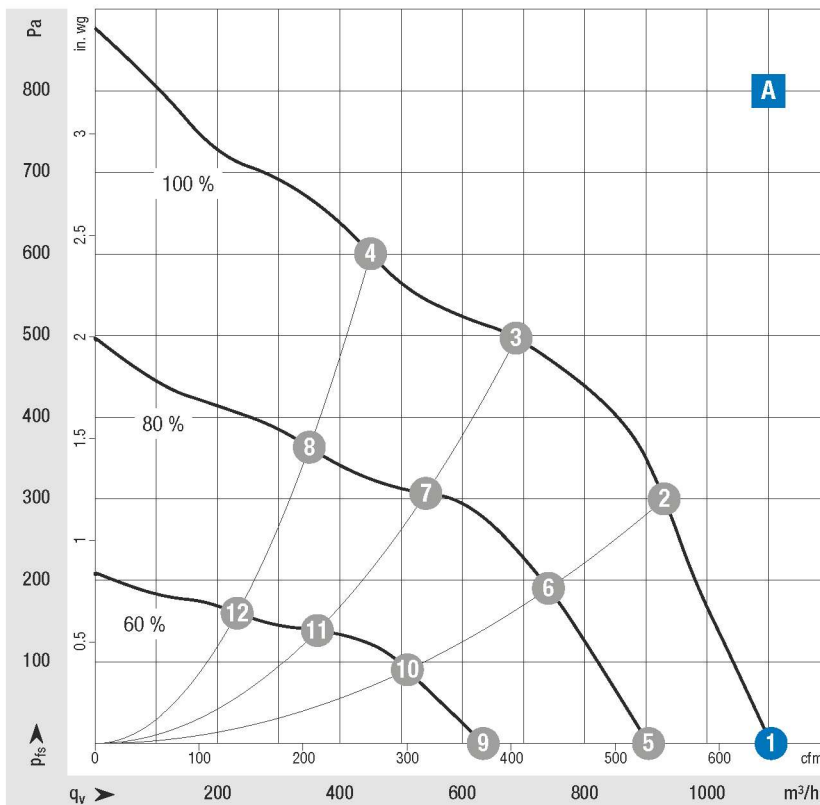

Measuring requirements

Air performance measured according to: ISO 5801, installation category A, with ebmpapst scroll housing without contact protection. Intake-side sound level: L_{wA} according to 13347, L_{wA} measured at 1 m distance from fan axis. The values given are only applicable under the specified measuring conditions and may differ depending on the installation conditions. In the event of deviation from the standard configuration, the parameters must be checked in installed condition.

Curve	Operating point	Nominal voltage		Speed n	Max. Input power P _{ed}	Max. Input current I	Sound power level L _{WA}	Installation position	Perm. ambient temp.	Degree of protection	Insulation class	Conn. diagram
		VDC	rpm									
Nominal voltage range 16-32 V DC												
A	1	26	4040	344	13,3	81	Any	-40..+85 (above +75 °C with power derating)	IP 24 KM (without connector)	B	TR3)	
	2	26	4275	306	11,8	81						
	3	26	4595	251	9,7	80						
	4	26	4795	218	8,4	80						
	5	26	3305	186	7,2	73						
	6	26	3425	158	6,1	71						
	7	26	3615	128	5,0	70						
	8	26	3735	107	4,1	69						
	9	26	2325	67	2,6	64						
	10	26	2385	58	2,3	62						
	11	26	2455	45	1,7	61						
	12	26	2505	38	1,5	60						

Values set in blue are nominal data at operating point with maximum load.

Subject to change

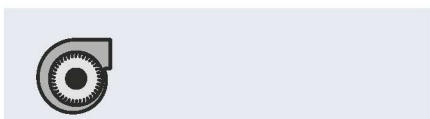

Curve	BL-DC dual centrifugal fans with housing		
	Type	Part number	Weight
A	VFD0097XUNES	K3G097BK3465	2,20 kg

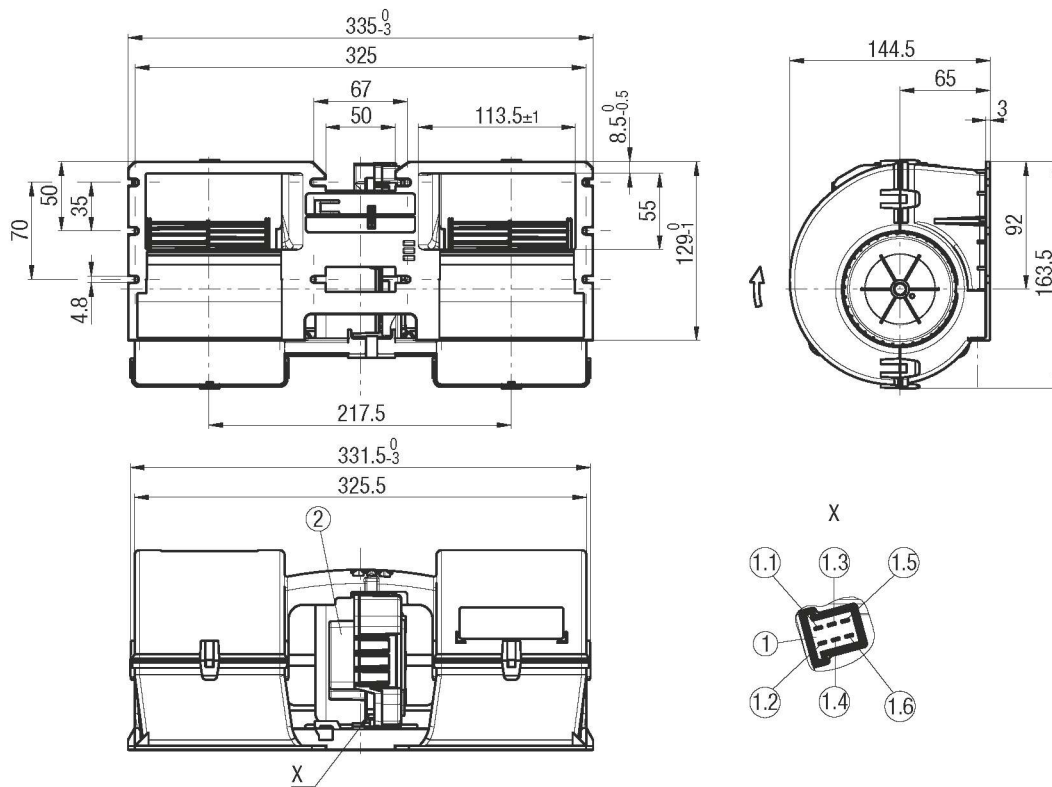

① 6-pole header TE Junior Power Timer WE_9901118:

Accessory part: Cable (460 mm) with mating connector, part no. 02001-4-1021 not included in scope of delivery, 6-pole mating connector TE 929504-2, 4x plug contact TE 927771-1, 2x plug contact TE 927768-1

② Electronics cover blue (RAL 5015)

Pin assignment: (see connection diagram)

- ①.1 + UB
- ①.2 GND
- ①.3 PWM/LIN, 100% speed
- ①.4 80% speed
- ①.5 60% speed
- ①.6 Not used / no function



BL-DC axial fans "Premium & Power" Ø 250 - Ø 385

ebmpapst

the engineer's choice

	Page
Ø 250	32
Ø 300	36
Ø 385	44

BL-DC axial fans

for commercial vehicle applications, Ø 250 mm



Material/surface

- Impeller: PP plastic
- Housing: PA plastic

Mechanical data

- Direction of rotation: Clockwise viewed toward rotor
- Direction of air flow: "V"
- Mode: Continuous operation (S1)
- Mounting: Maintenance-free ball bearings, sealed

Standards and approvals

- Approvals: EAC, E1 in preparation

on Page 34	Drawings
on Page 88	Accessories
on Page 98	Connection diagrams and technical features
on Page 114	Technical parameters & scope
More at	www.ebmpapst.com

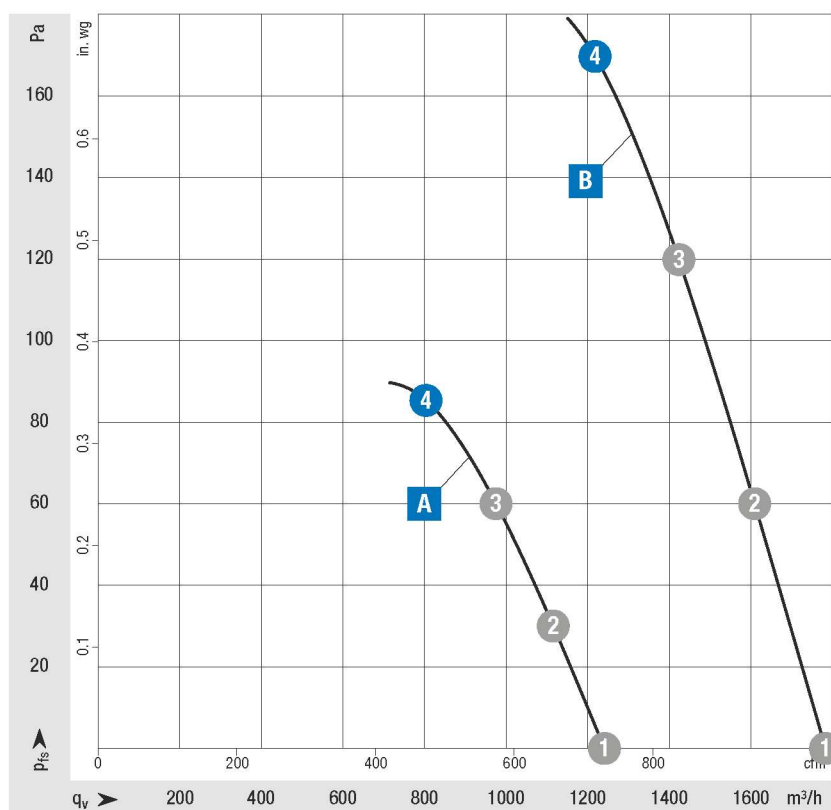

Measuring requirements

Air performance measured according to: ISO 5801, installation category A, without contact protection.
 Intake-side sound level: L_{pA} according to 13347, L_{pA} measured at 1 m distance from fan axis. The values given are only applicable under the specified measuring conditions and may differ depending on the installation conditions. In the event of deviation from the standard configuration, the parameters must be checked in installed condition.

Curve	Operating point	Nominal voltage	Speed n	Max. Input power P _{ed}	Max. Input current I	Sound power level L _{WA}	Installation position	Perm. ambient temp.	Degree of protection	Insulation class	Conn. diagram
		VDC									
Nominal voltage range 16-32 V DC											
A	1	26	2050	38	1,45	67	Any	-40..+85 (above +70 °C with power derating)	Motor: IP 24 KM Electronics: IP 66/69 K (mating conn. installed)	B	TR4)
	2	26	2020	42	1,61	66					
	3	26	1990	45	1,72	66					
	4	26	1965	47	1,80	66					
B	1	26	3000	110	4,20	77	Any	-40..+85 (above +70 °C with power derating)	Motor: IP 24 KM Electronics: IP 66/69 K (mating conn. installed)	B	TR4)
	2	26	2905	118	4,56	75					
	3	26	2855	128	4,95	74					
	4	26	2835	136	5,27	75					

Values set in blue are nominal data at operating point with maximum load.

Subject to change

Curve			
	BL-DC axial fans		
	Type	Part number	Weight kg
A	VWS0250XUNBS	W3G250EC2401	1,10
B	VWS0250XUNBS	W3G250EC2811	1,10

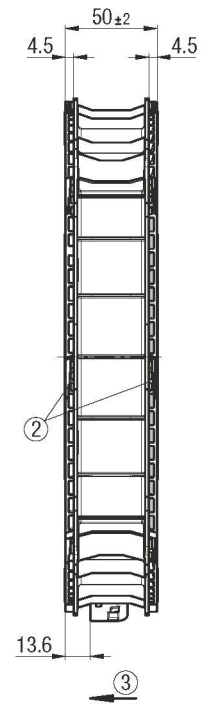
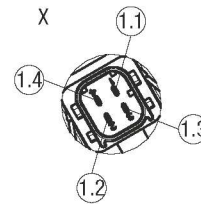
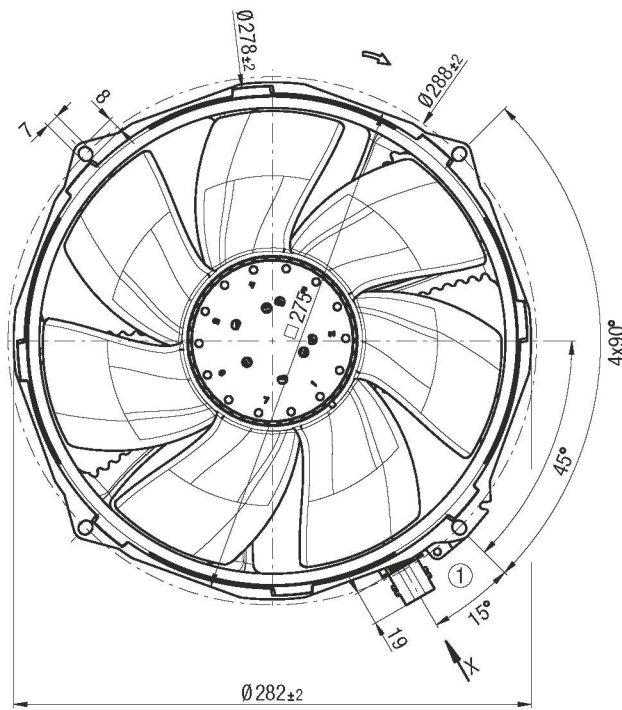

① 4-pole plug, pluggable with cable from accessories:

Accessory part: Cable (460 mm) with mating connector, part no. 02025-4-1021 not included in scope of delivery, 4-pole mating connector TE 1-1418390-1, 2x socket TE 968857-1, 2x socket TE 968855-1, 2x seal TE 828905-1, 2x seal TE 828904-1

② Bayonet attachment (both sides):

For sheet metal or plastic 1,5 / 2,0 or 2,5 mm thick. Alternatively four fastening holes in each case (on both sides). A detailed drawing of the recess required for bayonet attachment can be obtained from ebm-papst.

③ Direction of air flow "V"

Pin assignment: (see connection diagram)

- ①.1 PWM/LIN
- ①.2 Diagnostic output
- ①.3 + UB
- ①.4 GND

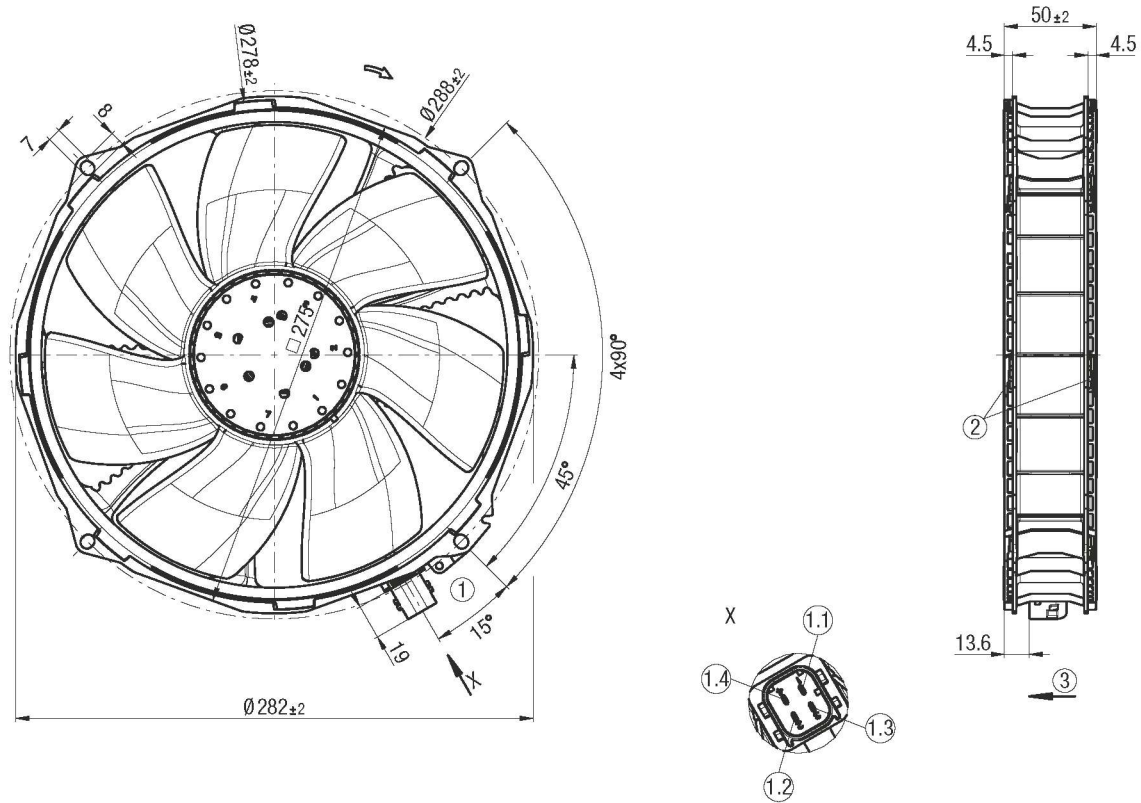

① 4-pole plug, pluggable with cable from accessories:

Accessory part: Cable (460 mm) with mating connector, part no. 02025-4-1021 not included in scope of delivery, 4-pole mating connector TE 1-1418390-1, 2x socket TE 968857-1, 2x socket TE 968855-1, 2x seal TE 828905-1, 2x seal TE 828904-1

② Bayonet attachment (both sides):

For sheet metal or plastic 1,5 / 2,0 or 2,5 mm thick. Alternatively four fastening holes in each case (on both sides). A detailed drawing of the recess required for bayonet attachment can be obtained from ebm-papst.

③ Direction of air flow "V"

Pin assignment: (see connection diagram)

- ①.1 PWM/LIN
- ①.2 Diagnostic output
- ①.3 + UB
- ①.4 GND

BL-DC axial fans

for commercial vehicle applications, Ø 300 mm



Material/surface

- Impeller: PA plastic (UL94 HB), black
- Housing: PA plastic (UL94 HB), black

Mechanical data

- Direction of rotation: Clockwise viewed toward rotor
- Direction of air flow: "V"
- Mode: Continuous operation (S1)
- Mounting: Maintenance-free ball bearings, sealed

Standards and approvals

- Approvals: EAC, E1

on Page 38	Drawings
on Page 88	Accessories
on Page 98	Connection diagrams and technical features
on Page 114	Technical parameters & scope
More at	www.ebmpapst.com

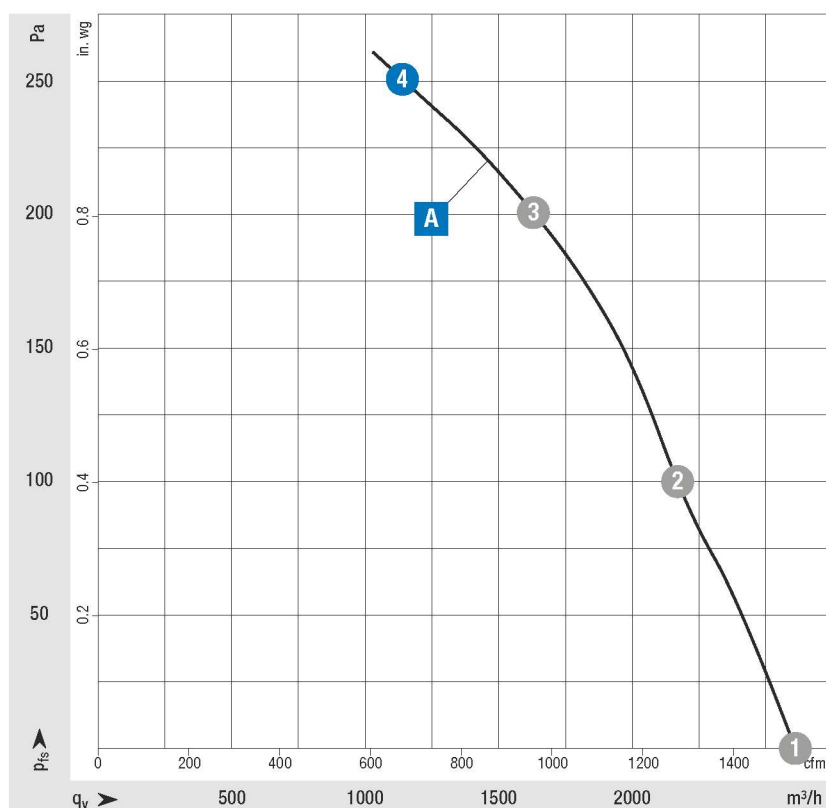

Measuring requirements

Air performance measured according to: ISO 5801, installation category A, without contact protection.
 Intake-side sound level: $L_{p,A}$ according to 13347, $L_{p,A}$ measured at 1 m distance from fan axis. The values given are only applicable under the specified measuring conditions and may differ depending on the installation conditions. In the event of deviation from the standard configuration, the parameters must be checked in installed condition.

Curve	Operating point	Nominal voltage		Speed n	Max. Input power P _{ed}	Max. Input current I	Sound power level L _{WA}	Installation position	Perm. ambient temp.	Degree of protection	Insulation class	Conn. diagram
		VDC	rpm									
Nominal voltage range 9-16 V DC												
A	1	13	3200	220	16,7	83	Any	-40..+85	Motor: IP 24 KM Electronics: IP 66/69 K	B	TR5)	
	2	13	3135	237	18,2	83						
	3	13	2955	248	19,0	80						
	4	13	2845	248	19,0	81						

Values set in blue are nominal data at operating point with maximum load.

Subject to change

Curve			
	BL-DC axial fans		
	Type	Part number	Weight
A	VWS0300XUPCS	W3G300BV1241	2,00 kg

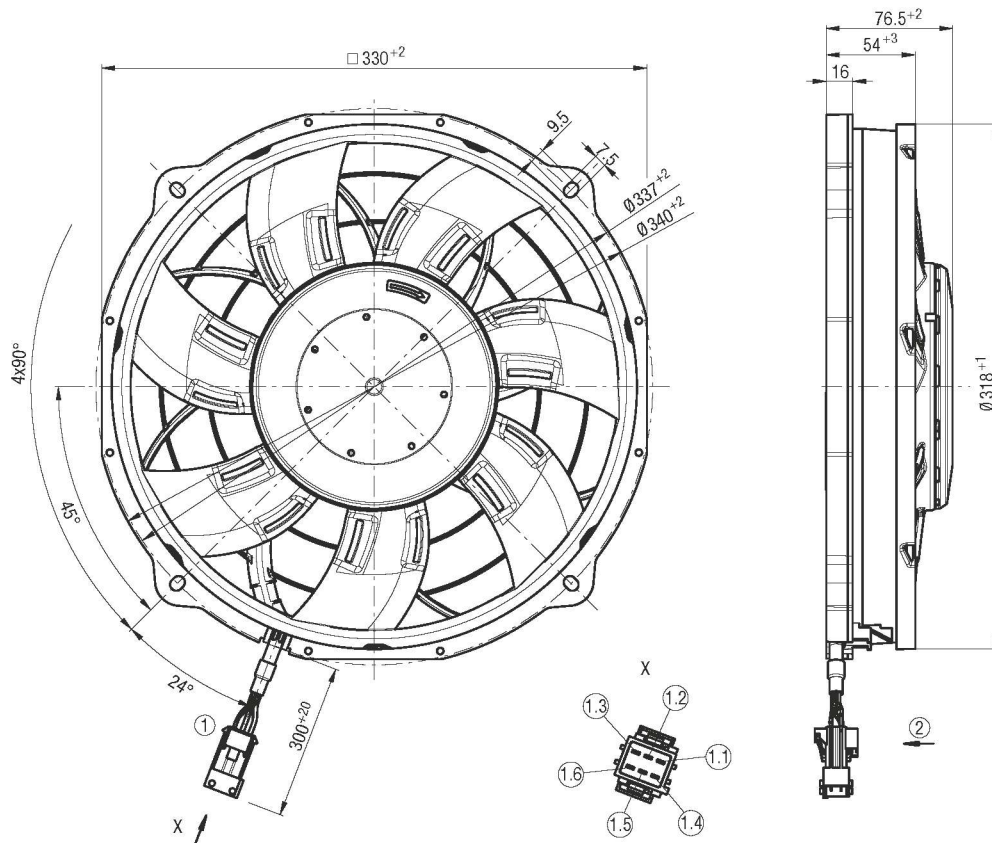

① Cable FLRYW 2x 3 mm², 4x 0,75 mm²:

6-pole connector housing TE 1-962349-1, 2x flat plug TE 2-962916-1, 3x flat plug TE 1-962915-1, 1x seal TE 963205-1, 2x seal TE 828905-1, 3x seal TE 828904-1, 1x dummy plug TE 828922-1
 6-pole mating connector TE 1-963212-1, 3x receptacle TE 929939-1, 2x receptacle TE 929937-1, 1x dummy plug TE 828922-1

② Direction of air flow "V"

Pin assignment: (see connection diagram)

- ①.1 + UB
- ①.2 GND
- ①.3 PWM/LIN
- ①.4 Not used / no function
- ①.5 ABSENK
- ①.6 Diagnostic output

BL-DC axial fans

for commercial vehicle applications, Ø 300 mm



Material/surface

- Impeller: PA plastic
- Housing: PP plastic

Mechanical data

- Direction of rotation: Clockwise viewed toward rotor
- Direction of air flow: "V"
- Mode: Continuous operation (S1)
- Mounting: Maintenance-free ball bearings, sealed

Standards and approvals

- Approvals: E1 in preparation

on Page 42	Drawings
on Page 88	Accessories
on Page 98	Connection diagrams and technical features
on Page 114	Technical parameters & scope
More at	www.ebmpapst.com

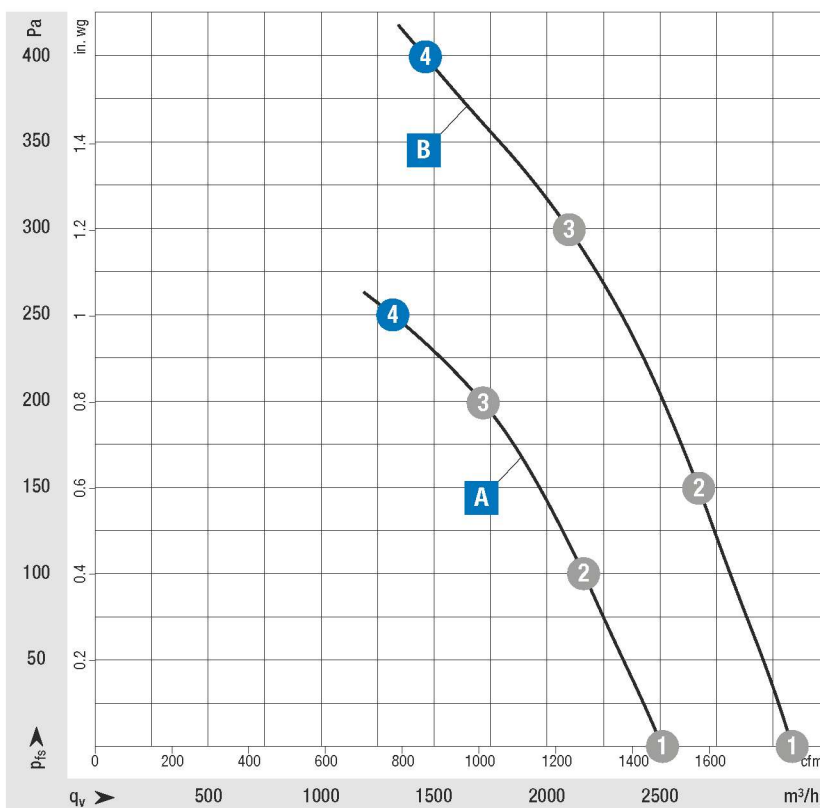

Measuring requirements

Air performance measured according to: ISO 5801, installation category A, without contact protection.
 Intake-side sound level: L_{pA} according to 13347, L_{pA} measured at 1 m distance from fan axis. The values given are only applicable under the specified measuring conditions and may differ depending on the installation conditions. In the event of deviation from the standard configuration, the parameters must be checked in installed condition.

Curve	Operating point	Nominal voltage		Speed n	Max. Input power P _{ed}	Max. Input current I	Sound power level L _{WA}	Installation position	Perm. ambient temp.	Degree of protection	Insulation class	Conn. diagram
		VDC	rpm									
Nominal voltage range 16-32 V DC												
A	1	26	3000	175	6,70	82	Any	-40..+85	Motor: IP 24 KM Electronics: IP 66/69 K (mating conn. installed)	B	TR1)	
	2	26	2930	186	7,17	81						
	3	26	2920	195	7,49	82						
	4	26	2915	194	7,47	84						
B	1	26	3650	320	12,4	88	Any	-40..+85 (above +70 °C with power derating)	Motor: IP 24 KM Electronics: IP 66/69 K (mating conn. installed)	B	TR1)	
	2	26	3650	347	13,3	87						
	3	26	3650	365	14,0	88						
	4	26	3650	376	15,5	91						

Values set in blue are nominal data at operating point with maximum load.

Subject to change

Curve			
	BL-DC axial fans		
	Type	Part number	Weight
A	VWS0300XUPCS	W3G300ME4701	2,00
B	VWS0300XUPCS	W3G300ME4811	2,00

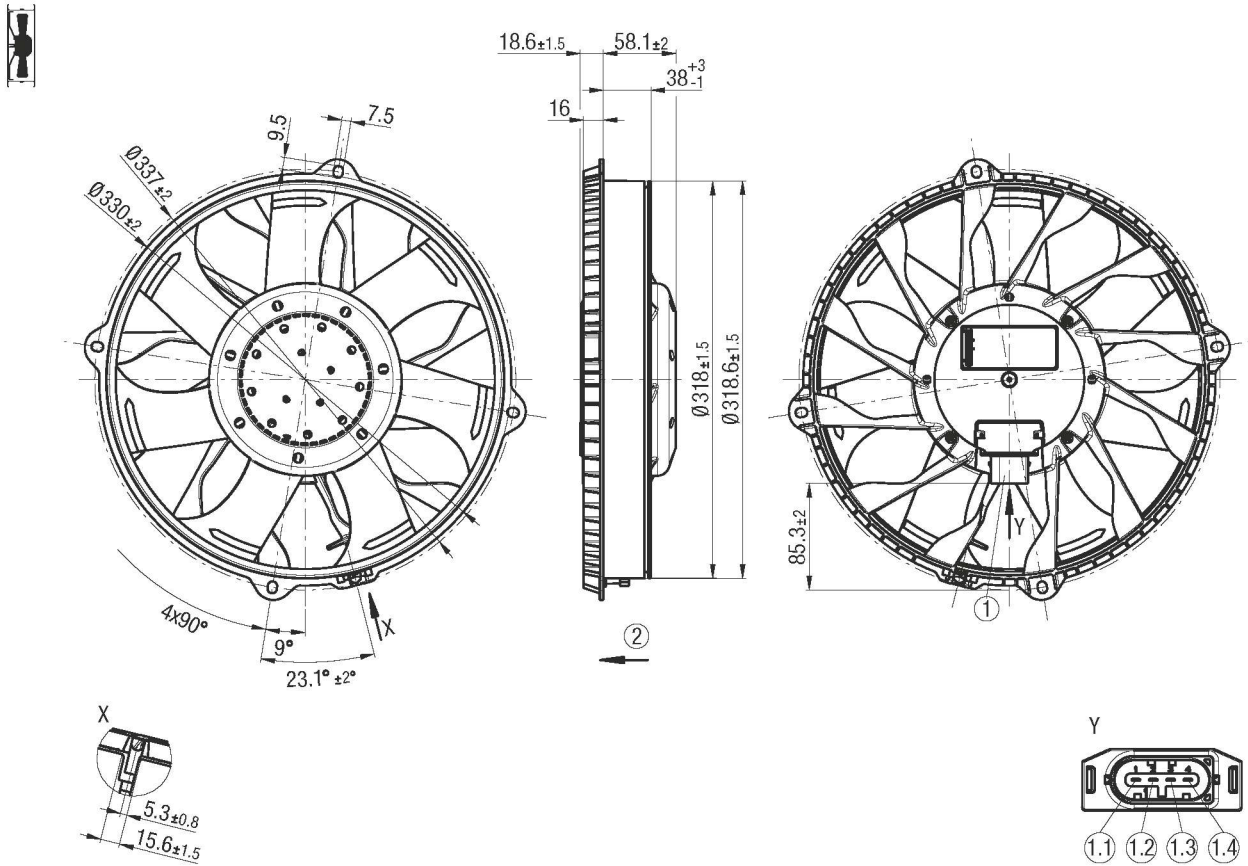

① 4-pole plug, pluggable with cable from accessories:

Accessory part: Cable (460 mm) with mating connector, part no. 02040-4-1021 not included in scope of delivery, 4-pole mating connector TE 1-1718628-1, 2x plug contact TE 1-968855-1, 2x plug contact TE 1-968857-1, 2x seal TE 828905-1, 2x seal TE 828904-1

② Direction of air flow "V"

Pin assignment: (see connection diagram)

- ①.1 Diagnostic output
- ①.2 PWM/LIN
- ①.3 + UB
- ①.4 GND

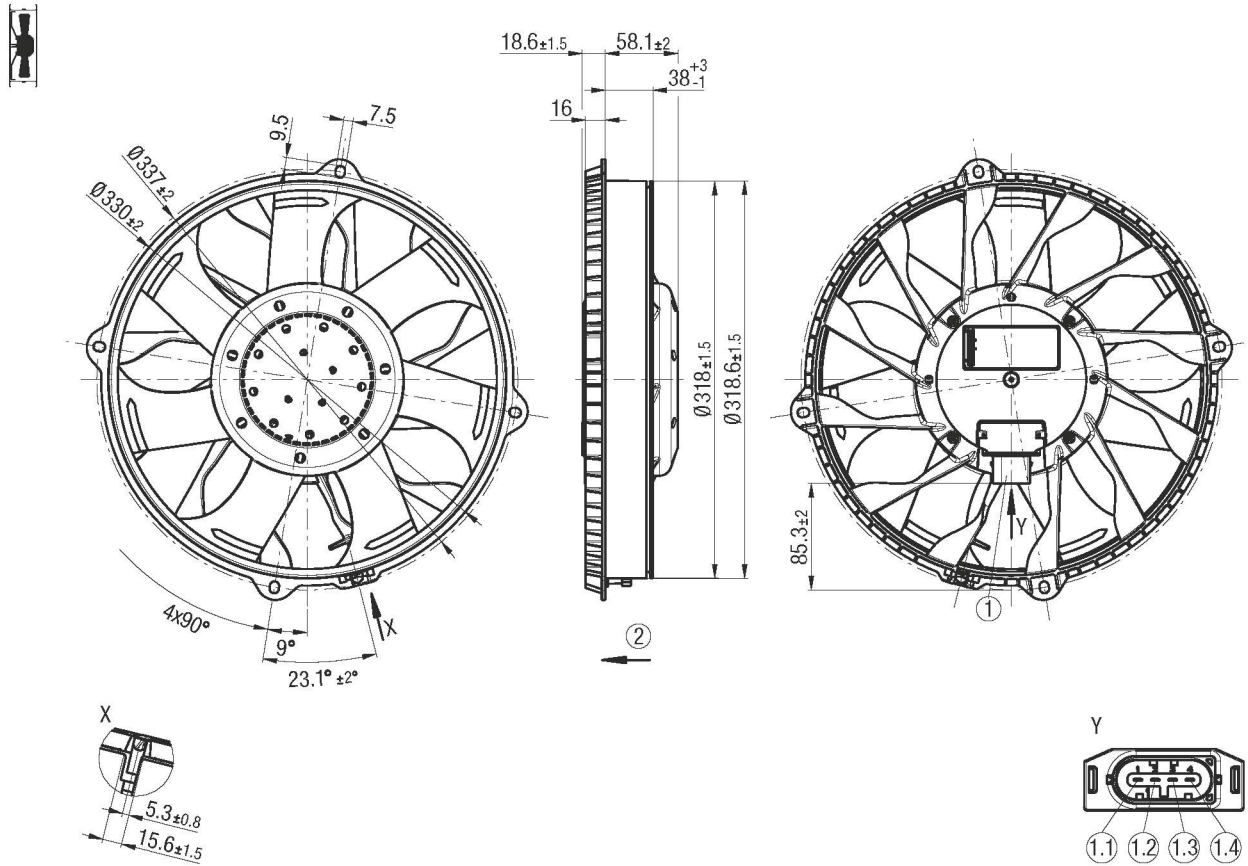

① 4-pole plug, pluggable with cable from accessories:

Accessory part: Cable (460 mm) with mating connector, part no. 02040-4-1021 not included in scope of delivery, 4-pole mating connector TE 1-1718628-1, 2x plug contact TE 1-968855-1, 2x plug contact TE 1-968857-1, 2x seal TE 828905-1, 2x seal TE 828904-1

② Direction of air flow "V"

Pin assignment: (see connection diagram)

- ①.1 Diagnostic output
- ①.2 PWM/LIN
- ①.3 + UB
- ①.4 GND

BL-DC axial fans

for commercial vehicle applications, Ø 385 mm



Material/surface

- Impeller: PA plastic
- Housing: PA plastic

Mechanical data

- Direction of rotation: Clockwise viewed toward rotor
- Direction of air flow: "V"
- Mode: Continuous operation (S1)
- Mounting: Maintenance-free ball bearings, sealed

Standards and approvals

- Approvals: EAC, E1

on Page 46	Drawings
on Page 88	Accessories
on Page 98	Connection diagrams and technical features
on Page 114	Technical parameters & scope
More at	www.ebmpapst.com

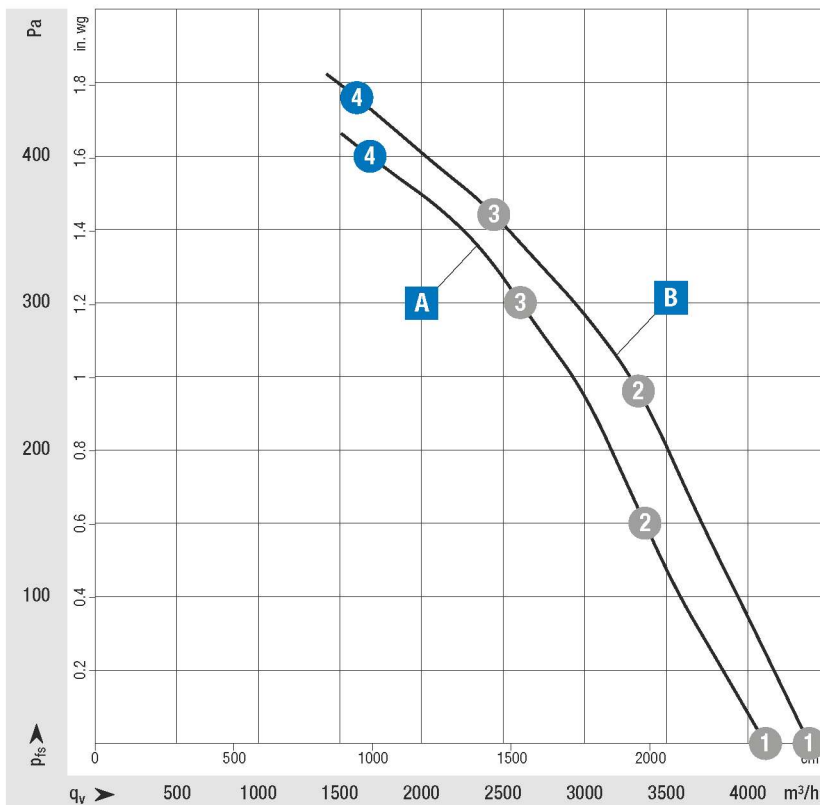

Measuring requirements

Air performance measured according to: ISO 5801, installation category A, without contact protection.
 Intake-side sound level: L_{pA} according to 13347, L_{pA} measured at 1 m distance from fan axis. The values given are only applicable under the specified measuring conditions and may differ depending on the installation conditions. In the event of deviation from the standard configuration, the parameters must be checked in installed condition.

Curve	Operating point	Nominal voltage		Max. Input power P_{ed}	Max. Input current I	Sound power level L_{WA}	Installation position	Perm. ambient temp.	Degree of protection	Insulation class	Conn. diagram
		VDC	rpm								
Nominal voltage range 9-16 V DC											
A	1	13	3100	445	34,0	89	Any	-40..+105 (above +70 °C with power derating)	Motor: IP 24 KM Electronics: IP 66/69 K (mating conn. installed)	B	TR6)
	2	13	3000	487	37,6	89					
	3	13	2935	556	42,6	87					
	4	13	2840	591	45,5	88					
Nominal voltage range 16-32 V DC											
B	1	26	3300	525	20,0	90	Any	-40..+110 (above +85 °C with power derating)	Motor: IP 24 KM Electronics: IP 66/69 K (mating conn. installed)	B	TR7)
	2	26	3170	618	23,8	88					
	3	26	3030	610	23,4	88					
	4	26	2900	613	23,6	89					

Values set in blue are nominal data at operating point with maximum load.

Subject to change

Curve			
	BL-DC axial fans		
	Type	Part number	Weight kg
A	VWS0385XUPES	W3G385CT5361	3,10
B	VWS0385XUPES	W3G385CT6521	3,10

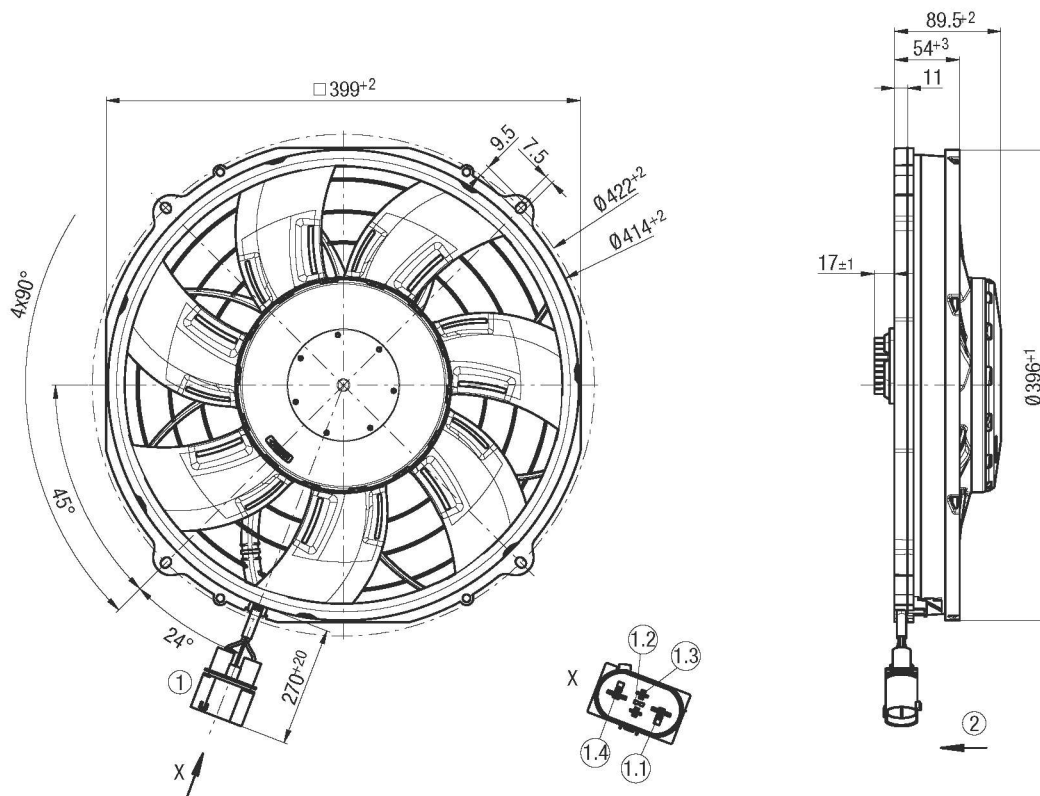

- ① Cable FLRYW 2x 6,0 mm², 2x 1,0 mm²:
4-pole connector housing Amphenol F353200, 2x flat plug FCI 60170261, 2x flat plug TE 964310-1, 2x seal FCI 60993308, 2x seal TE 1394511-1, 4-pole mating connector Amphenol F004200, 2x flat plug FCI 60170261, 2x flat plug TE 927831-1, 2x seal FCI 60993308, 2x seal TE 1394511-1
- ② Direction of air flow "V"

Pin assignment: (see connection diagram)

- ①.1 + UB
- ①.2 Diagnostic output
- ①.3 PWM/LIN
- ①.4 GND

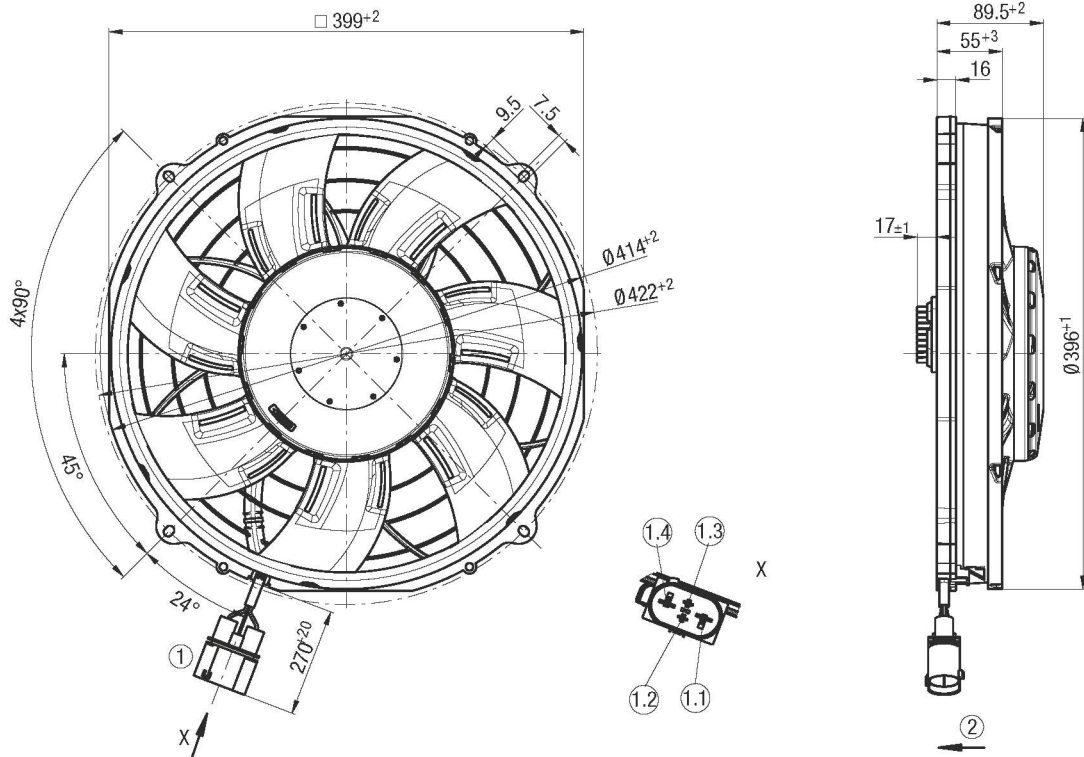

① Cable FLRYW 2x 6,0 mm², 2x 1,0 mm²:

4-pole connector housing Amphenol F353200, 2x flat plug FCI 60170261, 2x flat plug TE 964310-1, 2x seal FCI 60993308, 2x seal TE 1394511-1, 4-pole mating connector Amphenol F004200, 2x flat plug FCI 60170261, 2x flat plug TE 927831-1, 2x seal FCI 60993308, 2x seal TE 1394511-1

② Direction of air flow "V"

Pin assignment: (see connection diagram)

- ①.1 + UB
- ①.2 Diagnostic output
- ①.3 PWM/LIN
- ①.4 GND

BL-DC axial fans

for commercial vehicle applications, Ø 385 mm



Material/surface

- Impeller: PA plastic
- Housing: PA plastic

Mechanical data

- Direction of rotation: Clockwise viewed toward rotor
- Direction of air flow: "V"
- Mode: Continuous operation (S1)
- Mounting: Maintenance-free ball bearings, sealed

Standards and approvals

- Approvals: EAC, E1

on Page 50	Drawings
on Page 88	Accessories
on Page 98	Connection diagrams and technical features
on Page 114	Technical parameters & scope
More at	www.ebmpapst.com

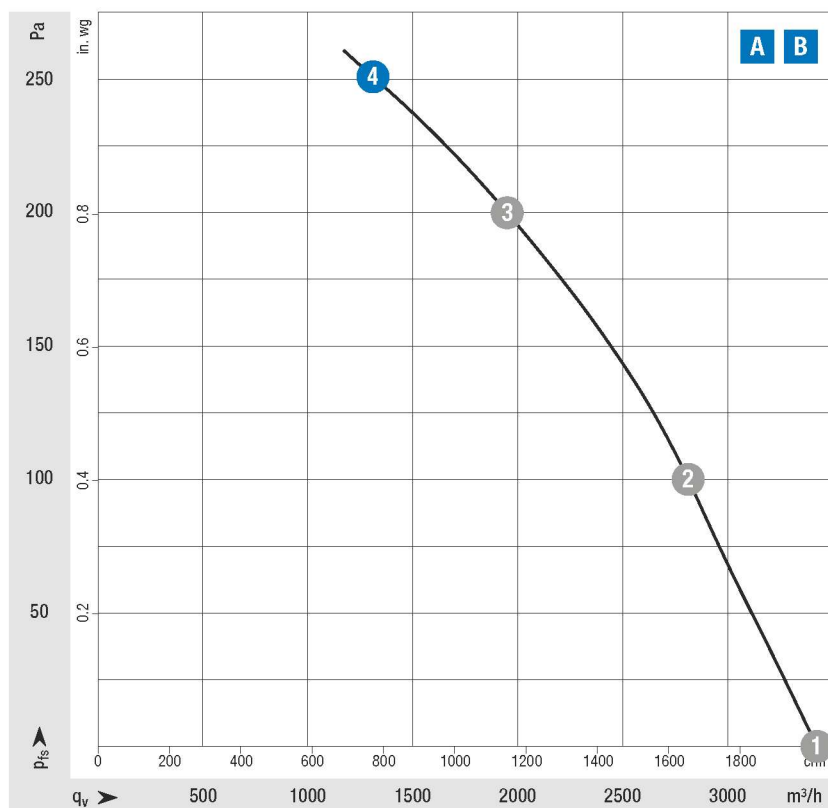

Measuring requirements

Air performance measured according to: ISO 5801, installation category A, without contact protection.
 Intake-side sound level: L_{vA} according to 13347, L_{vA} measured at 1 m distance from fan axis. The values given are only applicable under the specified measuring conditions and may differ depending on the installation conditions. In the event of deviation from the standard configuration, the parameters must be checked in installed condition.

Curve	Operating point	Nominal voltage		Speed n	Max. Input power P _{ed}	Max. Input current I	Sound power level L _{WA}	Installation position	Perm. ambient temp.	Degree of protection	Insulation class	Conn. diagram
		VDC	rpm									
Nominal voltage range 16-32 V DC												
A	1	26	2600	250	9,60	84	Any	-40..+110 (above +95 °C with power derating)	Motor: IP 24 KM Electronics: IP 66/69 K (mating conn. installed)	B	TR8)	
	2	26	2495	273	10,5	83						
	3	26	2315	273	10,5	81						
	4	26	2215	274	10,5	82						
B	1	26	2600	250	9,60	84	Any	-40..+110 (above +95 °C with power derating)	Motor: IP 24 KM Electronics: IP 66/69 K (mating conn. installed)	B	TR8)	
	2	26	2495	273	10,5	83						
	3	26	2315	273	10,5	81						
	4	26	2215	274	10,5	82						

Values set in blue are nominal data at operating point with maximum load.

Subject to change

Curve			
	BL-DC axial fans		
	Type	Part number	Weight kg
A	VWS0385XUPES	W3G385BV4401	2,70
B	VWS0385XUPES	W3G385BS4401	2,70

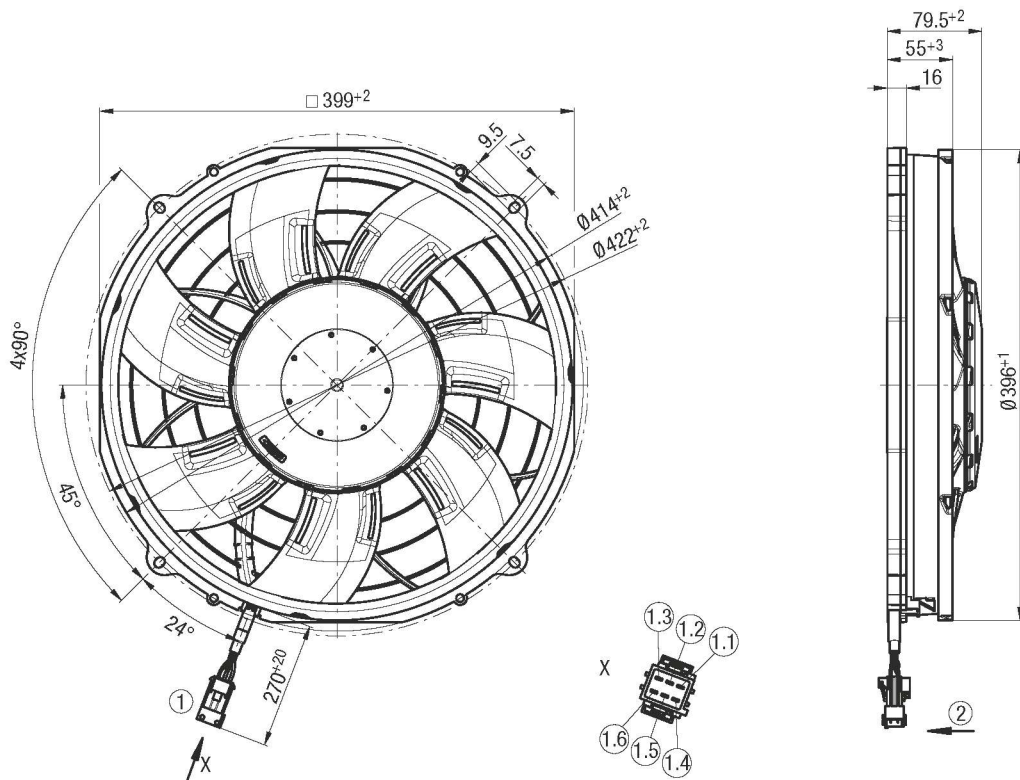

- ① Cable FLRYW 2x 1,5 mm², 4x 0,75 mm²:
 6-pole connector housing TE 1-962349-1, 2x flat plug TE 2-962916-1, 4x flat plug TE 1-962915-1, 1x seal TE 963205-1, 2x seal TE 828905-1, 4x seal TE 828904-1
 6-pole mating connector TE 1-963212-1, 4x receptacle TE 929939-1, 2x receptacle TE 929937-1
- ② Direction of air flow "V"

Pin assignment: (see connection diagram)

- ①.1 + UB
- ①.2 GND
- ①.3 PWM/LIN
- ①.4 INVLIN
- ①.5 ABSENK
- ①.6 Diagnostic output

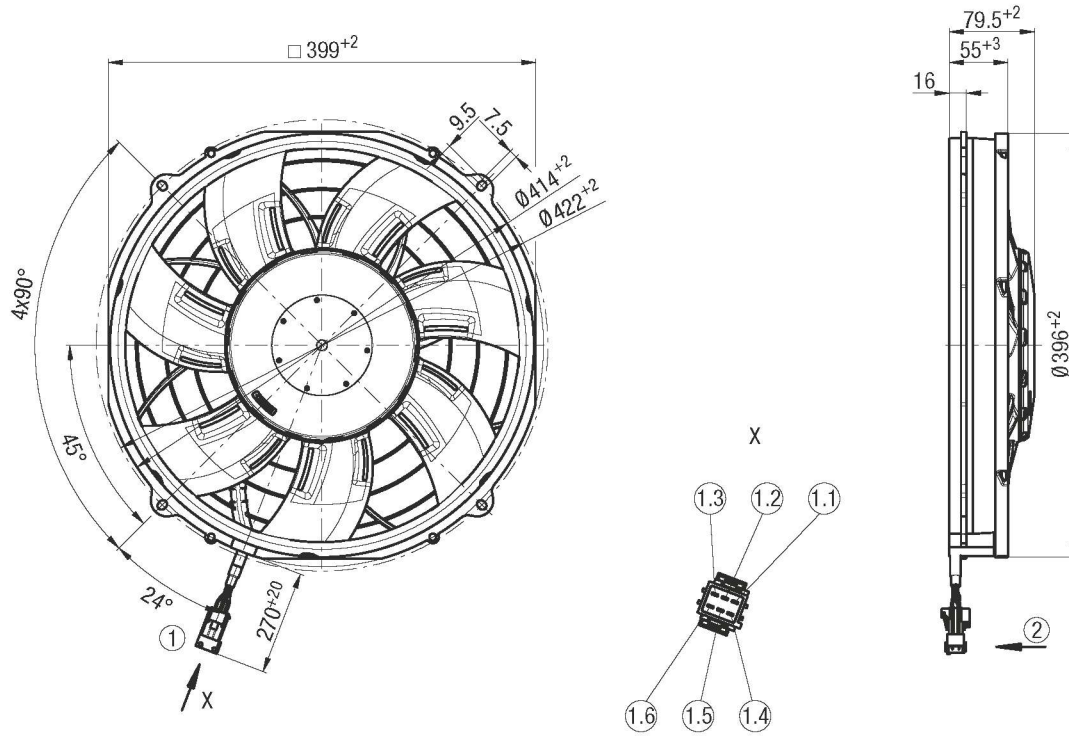

① Cable FLRYW 2x 1,5 mm², 4x 0,75 mm²:

6-pole connector housing TE 1-962349-1, 2x flat plug TE 2-962916-1, 4x flat plug TE 1-962915-1, 1x seal TE 963205-1, 2x seal TE 828905-1, 4x seal TE 828904-1
6-pole mating connector TE 1-963212-1, 4x receptacle TE 929939-1, 2x receptacle TE 929937-1

② Direction of air flow "V"

Pin assignment: (see connection diagram)

- ①.1 + UB
- ①.2 GND
- ①.3 PWM/LIN
- ①.4 INVLIN
- ①.5 ABSENK
- ①.6 Diagnostic output



BL-DC axial fans *"Heavy Duty"* Ø 300

ebmpapst

the engineer's choice

	Page
Ø 300	54

BL-DC axial fans

for commercial vehicle applications, Ø 300 mm



Material/surface

- Impeller: PA plastic
- Housing: PA plastic

Mechanical data

- Direction of rotation: Clockwise viewed toward rotor
- Direction of air flow: "V"
- Mode: Continuous operation (S1)
- Mounting: Maintenance-free ball bearings, sealed

Standards and approvals

- Approvals: EAC

on Page 56	Drawings
on Page 88	Accessories
on Page 98	Connection diagrams and technical features
on Page 114	Technical parameters & scope
More at	www.ebmpapst.com

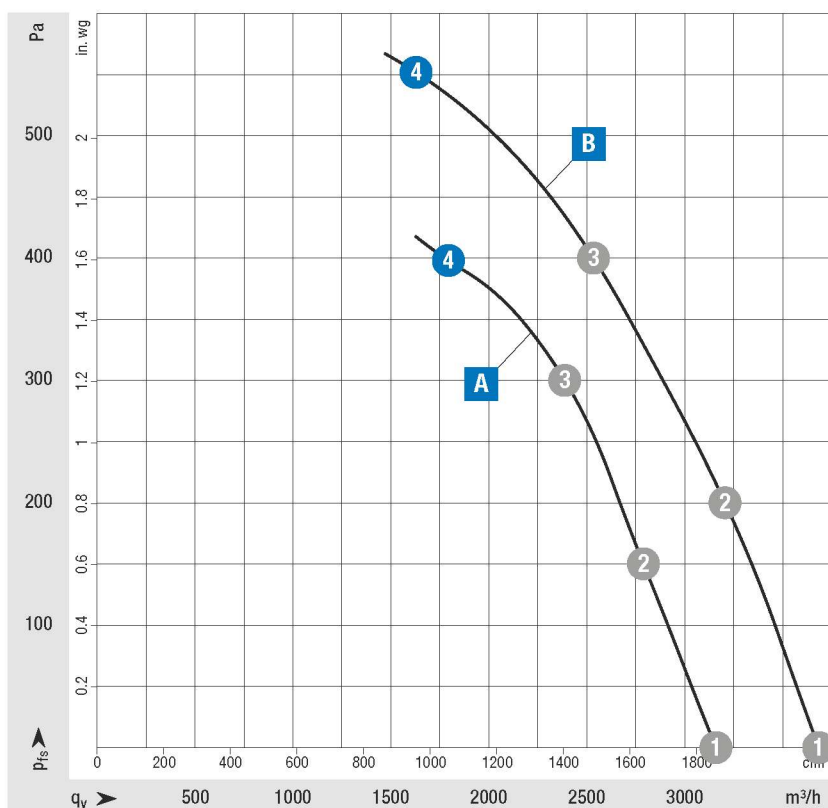

Measuring requirements

Air performance measured according to: ISO 5801, installation category A, without contact protection.
 Intake-side sound level: L_{vA} according to 13347, L_{vA} measured at 1 m distance from fan axis. The values given are only applicable under the specified measuring conditions and may differ depending on the installation conditions. In the event of deviation from the standard configuration, the parameters must be checked in installed condition.

Curve	Operating point	Nominal voltage		Speed n	Max. Input power P _{ed}	Max. Input current I	Sound power level L _{WA}	Installation position	Perm. ambient temp.	Degree of protection	Insulation class	Conn. diagram
		VDC	rpm									
Nominal voltage range 16-32 V DC												
A	1	26	3800	400	15,0	88	Any	-40..+85* (*for higher temperature on request)	Motor: IP 24 KM Electronics: IP 66/69 K (mating conn. installed)	B	TR9)	
	2	26	3725	426	16,4	87						
	3	26	3700	465	17,9	87						
	4	26	3700	462	17,7	89						
B	1	26	4400	630	24,0	92	Any	-40..+85 (above +60 °C with power derating)	Motor: IP 24 KM Electronics: IP 66/69 K (mating conn. installed)	B	TR7)	
	2	26	4250	673	25,9	91						
	3	26	4065	675	26,0	90						
	4	26	4065	679	26,1	92						

Values set in blue are nominal data at operating point with maximum load.

Subject to change

Curve			
	BL-DC axial fans		
	Type	Part number	Weight kg
A	VWS0300XUPCS	W3G300QX2523	2,20
B	VWS0300XUPCS	W3G300QX2640	2,20

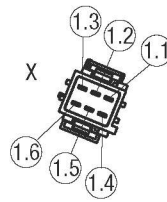
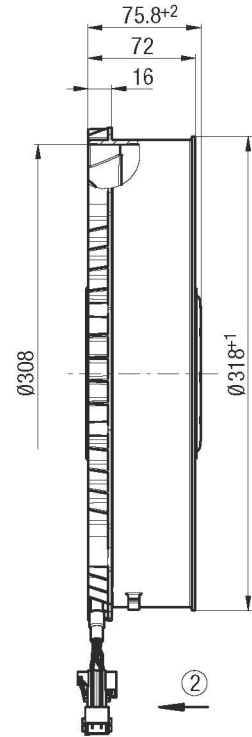
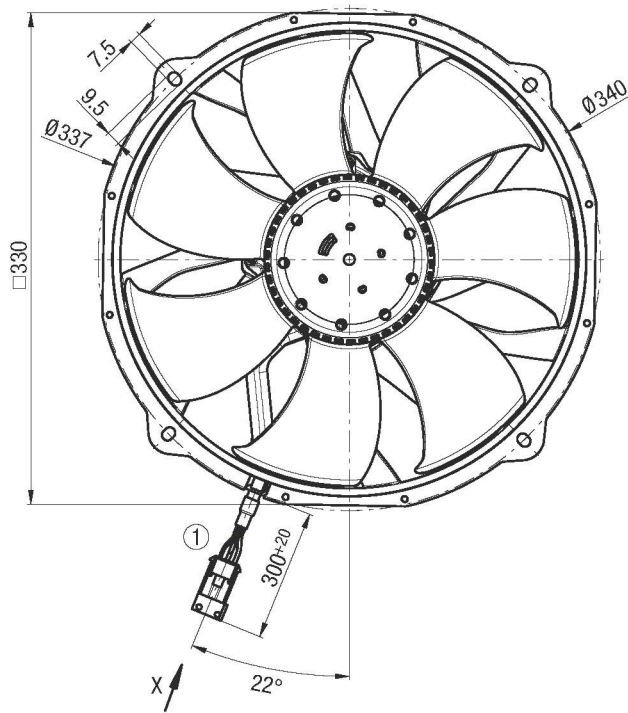

① Cable FLRYW 2x 3 mm², 3x 0,75 mm²:

6-pole connector housing TE 1-962349-1, 2x flat plug TE 2-962916-1, 3x flat plug TE 1-962915-1, 1x seal TE 963205-1, 2x seal TE 828905-1, 3x seal TE 828904-1, 1x dummy plug TE 828922-1, 6-pole mating connector TE 1-963212-1, 3x receptacle TE 929939-1, 2x receptacle TE 929937-1, 1x dummy plug TE 828922-1

② Direction of air flow "V"

Pin assignment: (see connection diagram)

- ①.1 + UB
- ①.2 GND
- ①.3 PWM/LIN
- ①.4 Not used / no function
- ①.5 Reverse
- ①.6 Diagnostic output

BL-DC axial fans

for commercial vehicle applications, Ø 300 mm



Material/surface

- Impeller: PA plastic
- Housing: PA plastic

Mechanical data

- Direction of rotation: Clockwise viewed toward rotor
- Direction of air flow: "V"
- Mode: Continuous operation (S1)
- Mounting: Maintenance-free ball bearings, sealed

Standards and approvals

- Approvals: EAC

on Page 60	Drawings
on Page 88	Accessories
on Page 98	Connection diagrams and technical features
on Page 114	Technical parameters & scope
More at	www.ebmpapst.com

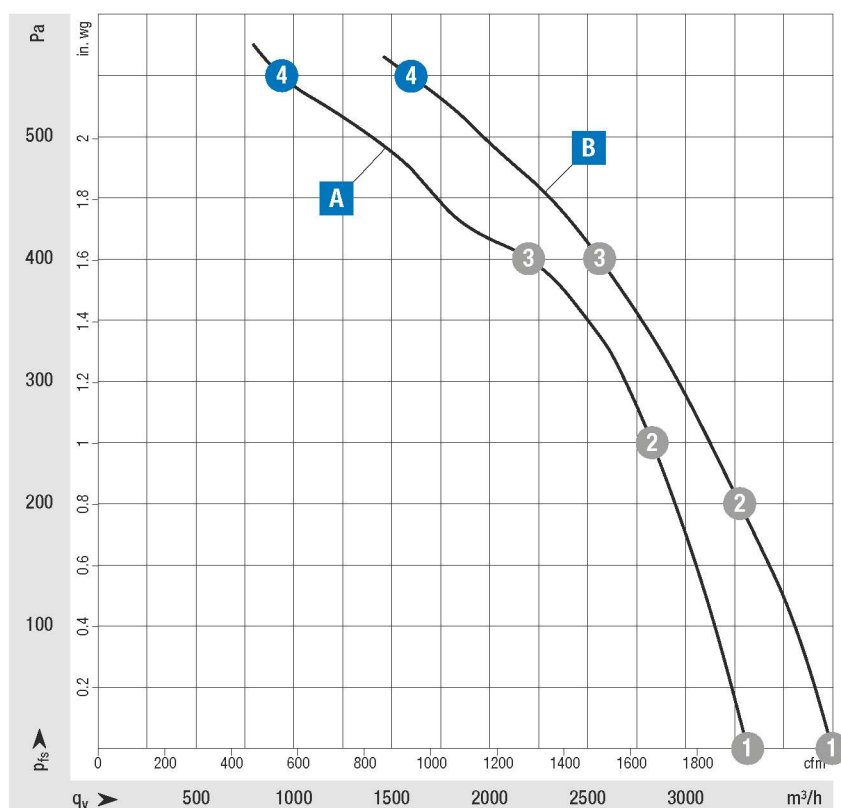

Measuring requirements

Air performance measured according to: ISO 5801, installation category A, without contact protection.
 Intake-side sound level: L_{pA} according to 13347, L_{pA} measured at 1 m distance from fan axis. The values given are only applicable under the specified measuring conditions and may differ depending on the installation conditions. In the event of deviation from the standard configuration, the parameters must be checked in installed condition.

Curve	Operating point	Nominal voltage		Speed n	Max. Input power P _{ed}	Max. Input current I	Sound power level L _{WA}	Installation position	Perm. ambient temp.	Degree of protection	Insulation class	Conn. diagram
		VDC	rpm									
Nominal voltage range 16-32 V DC												
A	1	26	3925	400	15,4	89	Any	-40..+85* (*for higher temperature on request)	Motor: IP 24 KM Electronics: IP 66/69 K (mating conn. installed)	B	TR9)	
	2	26	3935	516	19,8	88						
	3	26	3830	530	20,4	88						
	4	26	3620	499	19,2	92						
B	1	26	4400	630	24,0	92	Any	-40..+85 (above +60 °C with power derating)	Motor: IP 24 KM Electronics: IP 66/69 K (mating conn. installed)	B	TR7)	
	2	26	4250	673	25,9	91						
	3	26	4065	675	26,0	90						
	4	26	4065	679	26,1	92						

Values set in blue are nominal data at operating point with maximum load.

Subject to change

Curve			
	BL-DC axial fans		
	Type	Part number	Weight kg
A	VWS0300XUPCS	W3G300QY2523	2,20
B	VWS0300XUPCS	W3G300QY2640	2,20

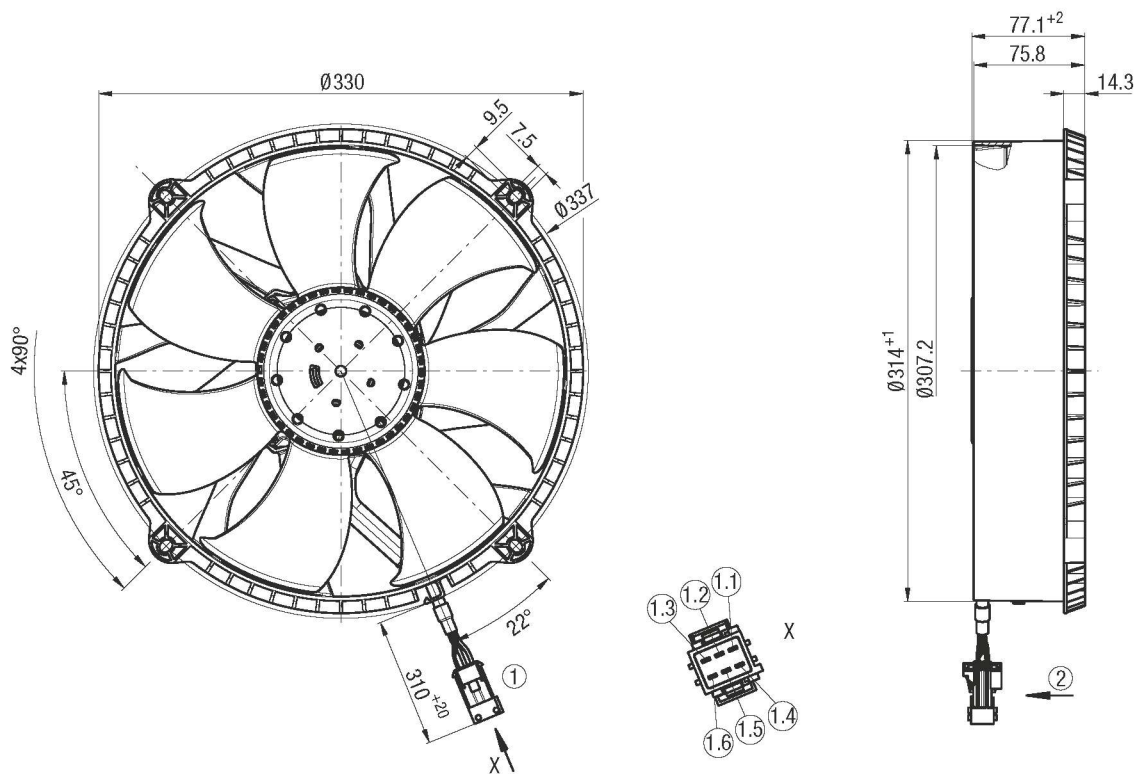

① Cable FLRYW 2x 3 mm², 3x 0,75 mm²:

6-pole connector housing TE 1-962349-1, 2x flat plug TE 2-962916-1, 3x flat plug TE 1-962915-1, 1x seal TE 963205-1, 2x seal TE 828905-1, 3x seal TE 828904-1, 1x dummy plug TE 828922-1, 6-pole mating connector TE 1-963212-1, 3x receptacle TE 929939-1, 2x receptacle TE 929937-1, 1x dummy plug TE 828922-1

② Direction of air flow "V"

Pin assignment: (see connection diagram)

- ①.1 + UB
- ①.2 GND
- ①.3 PWM/LIN
- ①.4 Not used / no function
- ①.5 Reverse
- ①.6 Diagnostic output

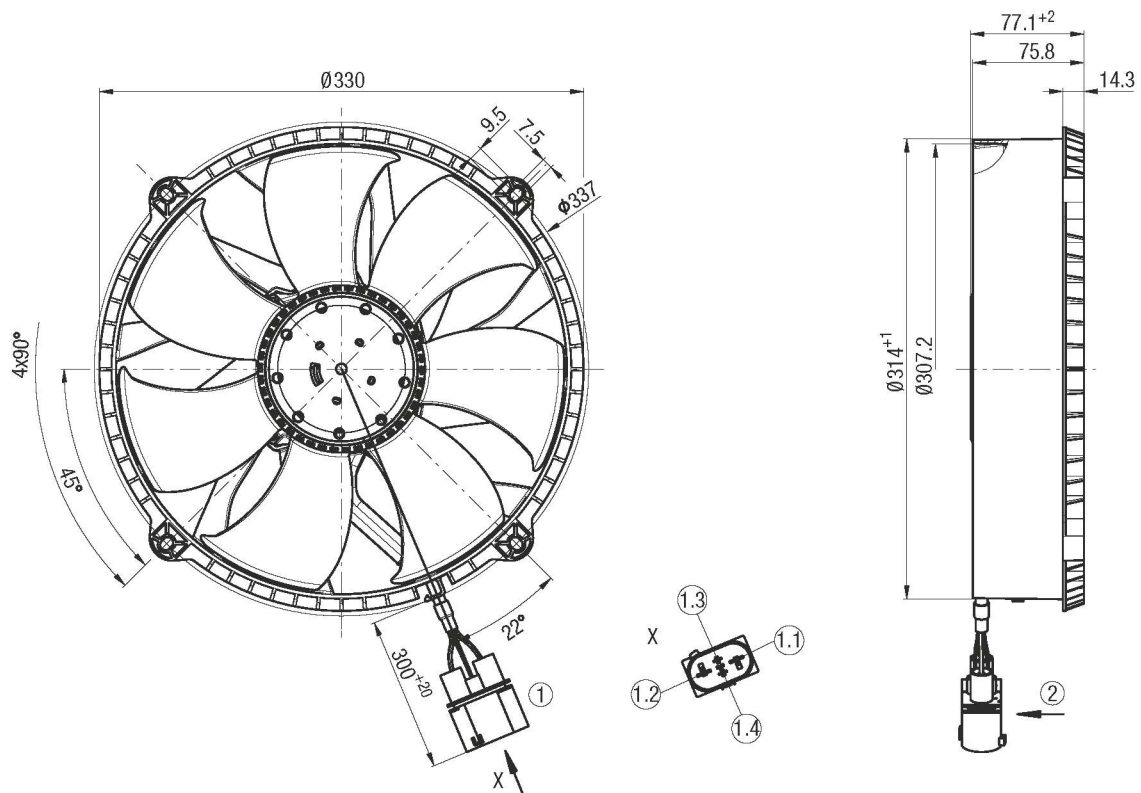

① Cable FLRYW 2x 6 mm², 2x 1 mm²:

4-pole connector housing Amphenol F353200, 2x flat plug FCI 60170261, 2x flat plug TE 964310-1, 2x seal FCI 60993308, 2x seal TE 1394511-1

4-pole mating connector Amphenol F004200, 2x flat plug FCI 60170261, 2x flat plug TE 927831-1, 2x seal FCI 60993308, 2x seal TE 1394511-1

② Direction of air flow "V"

Pin assignment: (see connection diagram)

①.1 + UB

①.2 GND

①.3 PWM/LIN

①.4 Diagnostic output



BL-DC axial fans "Basic" Ø 300

ebmpapst

the engineer's choice

	Page
Ø 300	64

BL-DC axial fans

for commercial vehicle applications, Ø 300 mm



Material/surface

- Impeller: PP plastic
- Housing: PP plastic

Mechanical data

- Direction of rotation: Clockwise viewed toward rotor
- Direction of air flow: "V"
- Mode: Continuous operation (S1)
- Mounting: Maintenance-free ball bearings

Standards and approvals

- Approvals: EAC, E1 in preparation

on Page 66	Drawings
on Page 88	Accessories
on Page 98	Connection diagrams and technical features
on Page 114	Technical parameters & scope
More at	www.ebmpapst.com

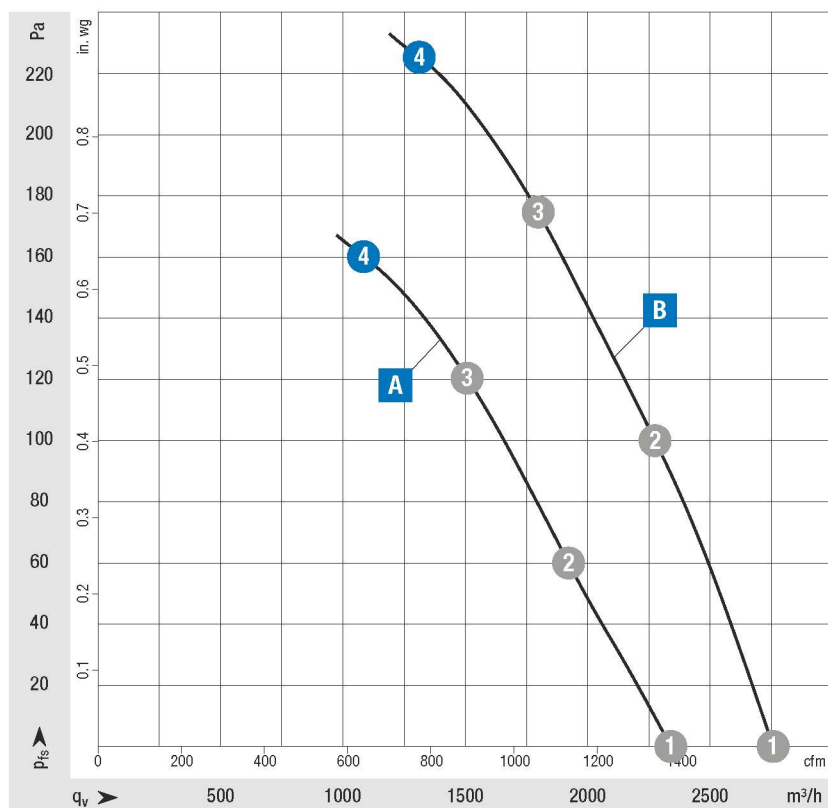

Measuring requirements

Air performance measured according to: ISO 5801, installation category A, without contact protection.
 Intake-side sound level: L_{vA} according to 13347, L_{vA} measured at 1 m distance from fan axis. The values given are only applicable under the specified measuring conditions and may differ depending on the installation conditions. In the event of deviation from the standard configuration, the parameters must be checked in installed condition.

Curve	Operating point	Nominal voltage	Speed n	Max. Input power P _{ed}	Max. Input current I	Sound power level L _{WA}	Installation position	Perm. ambient temp.	Degree of protection	Insulation class	Conn. diagram
		VDC									
Nominal voltage range 9-16 V DC											
A	1	13	2500	145	11,0	76	Any	-40..+85 (above +70 °C with power derating)	Motor: IP 24 KM Electronics: IP 66/69 K (mating conn. installed)	B	TR10)
	2	13	2455	145	11,0	78					
	3	13	2415	145	11,0	79					
	4	13	2365	142	10,9	80					
Nominal voltage range 16-32 V DC											
B	1	26	3000	225	8,50	81	Any	-40..+85 (above +75 °C with power derating)	Motor: IP 24 KM Electronics: IP 66/69 K (mating conn. installed)	B	TR11)
	2	26	2955	251	9,64	82					
	3	26	2925	249	9,58	83					
	4	26	2850	247	9,48	84					

Values set in blue are nominal data at operating point with maximum load.

Subject to change

Curve			
	BL-DC axial fans		
	Type	Part number	Weight
A	VWT0300XUNES	W1G300EC1220	2,60
B	VWT0300XUNES	W1G300EC2414	2,60

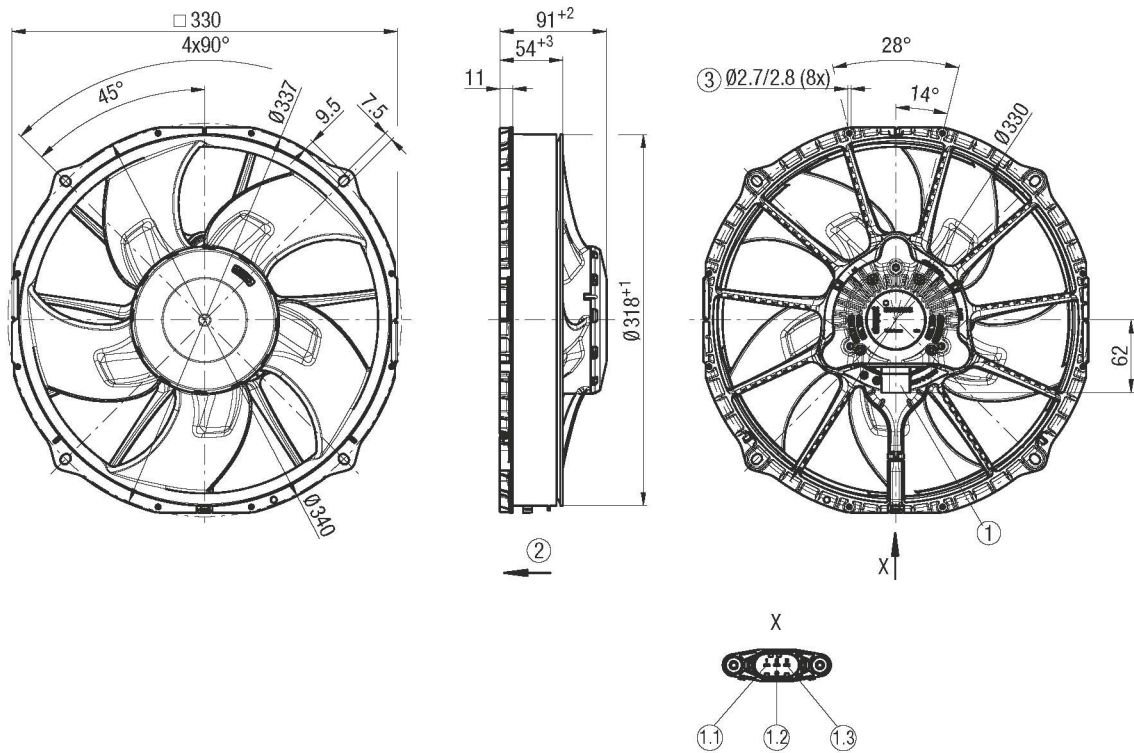

① Plug TE MCP 2.8, 3-pole, coded:

Accessory part: Cable (420 mm) with mating connector part no. 02020-4-1021 not included in scope of delivery, 3-pole mating connector TE 1-1718627-1, 2x socket TE 1241396-1, 1x socket TE 1241388-1, 2x seal TE 963292-1, 1x seal TE 963294-1

② Direction of air flow "V"

③ On both sides for screws for fastening plastics Ø 3,5 mm

Pin assignment: (see connection diagram)

- ①.1 + UB
- ①.2 0-10 V
- ①.3 GND

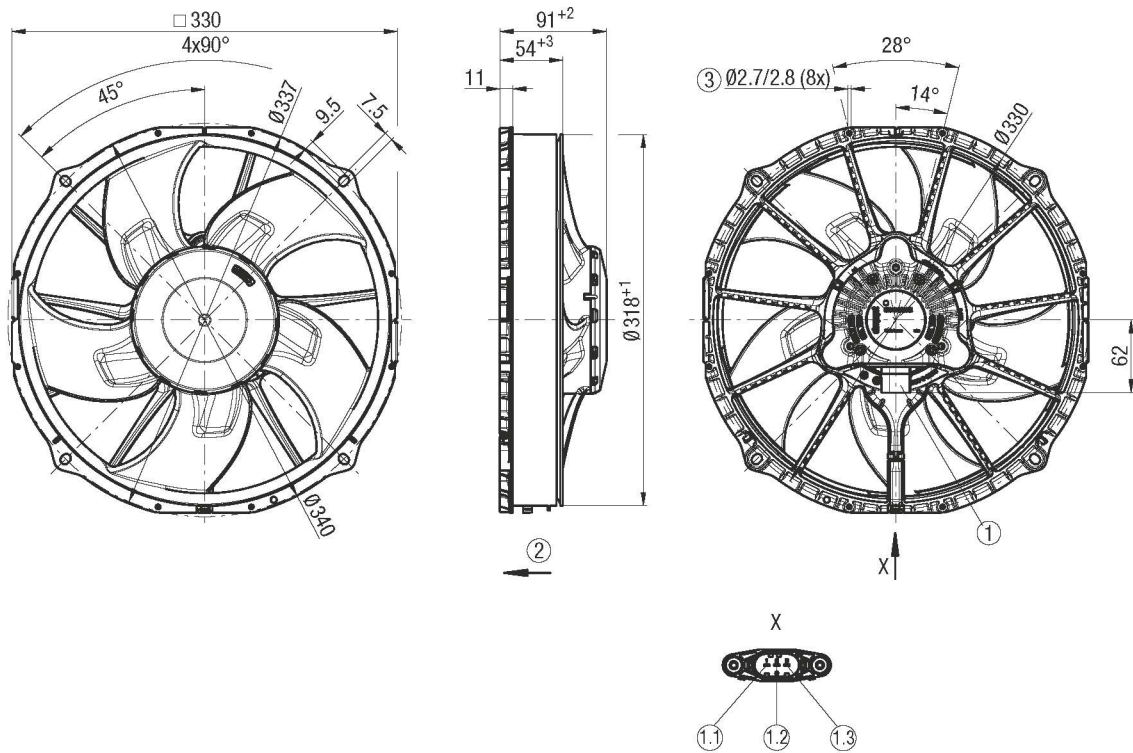

① Plug TE MCP 2.8, 3-pole, coded:

Accessory part: Cable (420 mm) with mating connector part no. 02020-4-1021 not included in scope of delivery, 3-pole mating connector TE 1-1718627-1, 2x socket TE 1241396-1, 1x socket TE 1241388-1, 2x seal TE 963292-1, 1x seal TE 963294-1

② Direction of air flow "V"

③ On both sides for screws for fastening plastics Ø 3,5 mm

Pin assignment: (see connection diagram)

- ①.1 + UB
- ①.2 0-10 V
- ①.3 GND



BL-DC centrifugal fans forward curved *without housing* Ø 146

ebmpapst

the engineer's choice

	Page
Ø 146	70

BL-DC centrifugal fans

vorward curved without housing, for commercial vehicle applications, Ø 146 mm



Material/surface

- Cover: PP plastic
- Impeller: PA plastic

Mechanical data

- Direction of rotation: Clockwise viewed toward rotor
- Mode: Continuous operation (S1)
- Mounting: Maintenance-free ball bearings, sealed

Standards and approvals

- Approvals: EAC, E1 in preparation

on Page 72	Drawings
on Page 88	Accessories
on Page 98	Connection diagrams and technical features
on Page 114	Technical parameters & scope
More at	www.ebmpapst.com

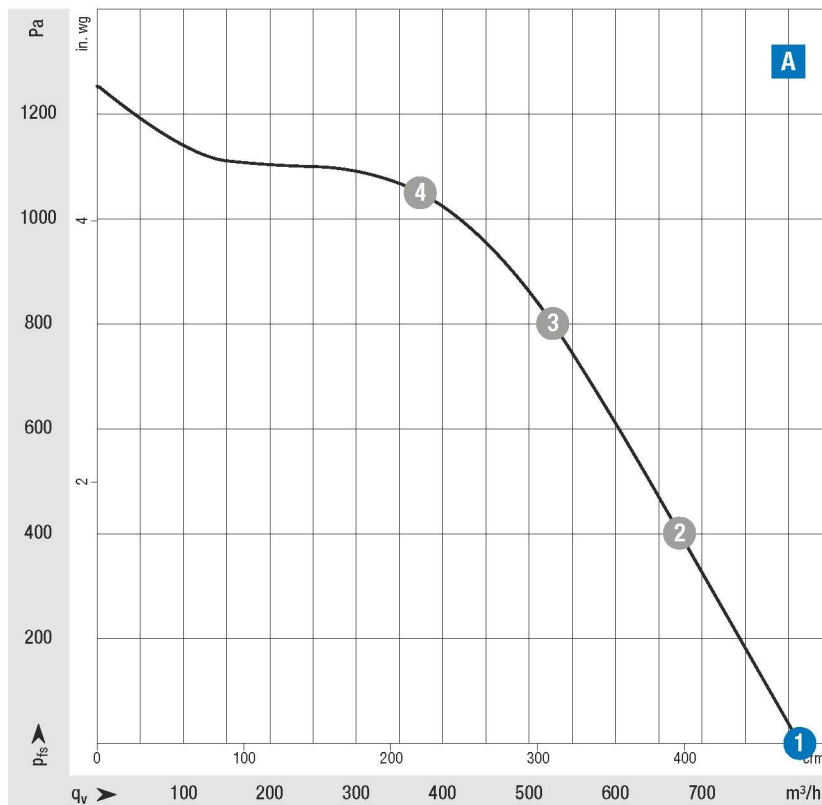

Measuring requirements

Air performance measured according to: ISO 5801, installation category A, with ebmpapst scroll housing without contact protection. Intake-side sound level: L_{pA} according to 13347, L_{pA} measured at 1 m distance from fan axis. The values given are only applicable under the specified measuring conditions and may differ depending on the installation conditions. In the event of deviation from the standard configuration, the parameters must be checked in installed condition.

Curve	Operating point	Nominal voltage	Speed n	Max. Input power P _{ed}	Max. Input current I	Sound power level L _{WA}	Installation position	Perm. ambient temp.	Degree of protection	Insulation class	Conn. diagram
		VDC	rpm	W	A	dB(A)		°C			
Nominal voltage range 16-32 V DC											
A	1	26	2750	280	10,8	79	Shaft horizontal or rotor on bottom	-40...+85 (above +75 °C with power derating)	Motor: IP 24 KM Electronics: IP 66/69 K (mating conn. installed)	B	TR4)
	2	26	3245	280	10,8	78					
	3	26	3815	280	10,8	78					
	4	26	4225	245	9,55	79					

Values set in blue are nominal data at operating point with maximum load.

Subject to change



Curve	BL-DC dual centrifugal fans without housing		
	Type	Part number	Weight
A	VFS0146XUPCS	R3G146EC5001	1,50 kg

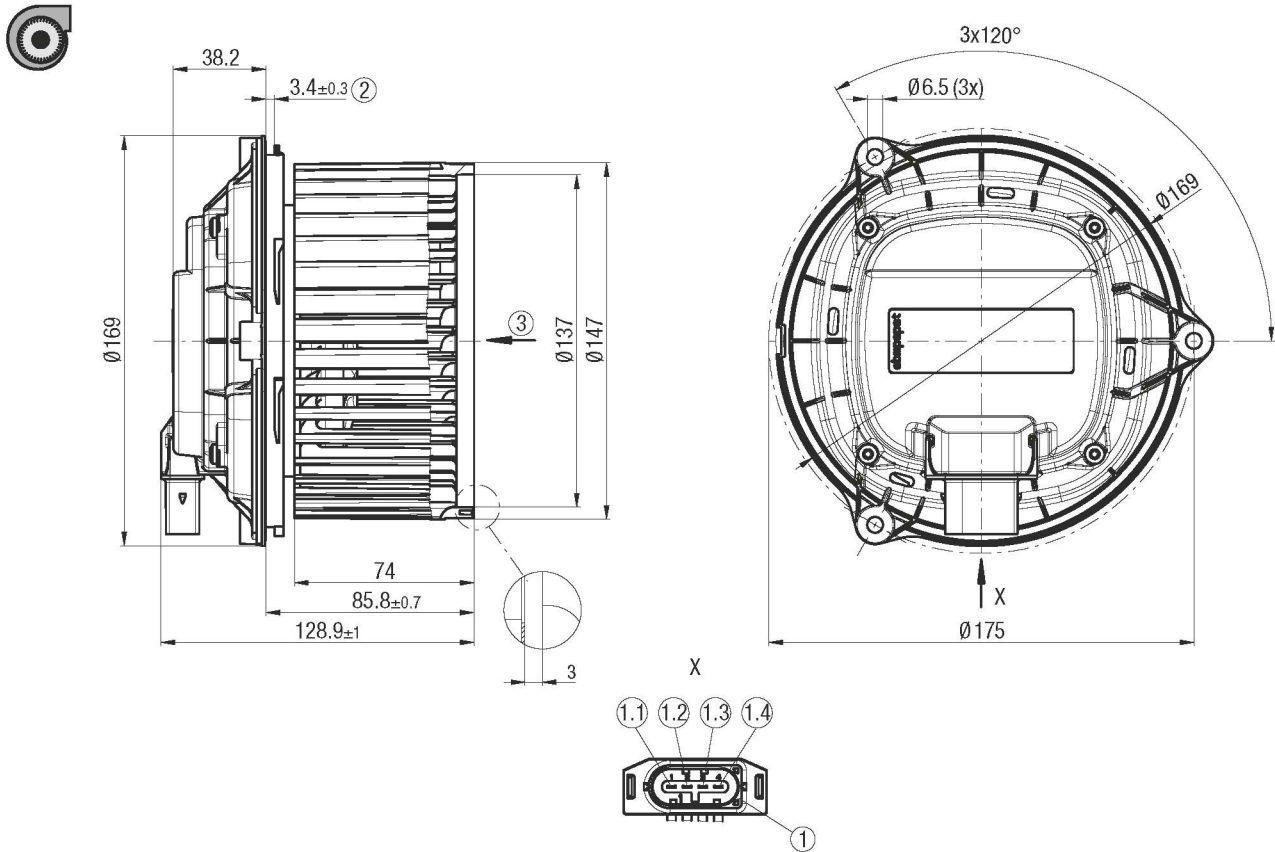

① 4-pole plug, pluggable with cable from accessories:

Accessory part: Cable (460 mm) with mating connector, part no. 02040-4-1021 not included in scope of delivery 4-pole mating connector TE 1-1718628-1, 2x plug contact TE 1-968855-1, 2x plug contact TE 1-968857-1, 2x seal TE 828905-1, 2x seal TE 828904-1

② Bayonet attachment for metal or plastic:

A detailed drawing of the recess required for bayonet attachment can be obtained from ebm-papst.

③ Max. permissible axial bearing loads: 50 N (brief periods during handling or installation)

Pin assignment: (see connection diagram)

- ①.1 Diagnostic output
- ①.2 PWM/LIN
- ①.3 + UB
- ①.4 GND

Scroll housing on request



BL-DC centrifugal fans - RadiCal *backward curved* Ø 220 - Ø 280

ebmpapst

the engineer's choice

	Page
Ø 220	76
Ø 250	80
Ø 280	84

BL-DC centrifugal fans - RadiCal

backward curved, for commercial vehicle applications, \varnothing 220 mm



Material/surface

- Impeller: PA plastic
- Rotor surface: Galvanized
- Electronics housing: Die-cast aluminum

Mechanical data

- Direction of rotation: Clockwise viewed toward rotor
- Mode: Continuous operation (S1)
- Mounting: Maintenance-free ball bearings, sealed

Standards and approvals

- Approvals: EAC

on Page 78	Drawings
on Page 88	Accessories
on Page 98	Connection diagrams and technical features
on Page 114	Technical parameters & scope
More at	www.ebmpapst.com

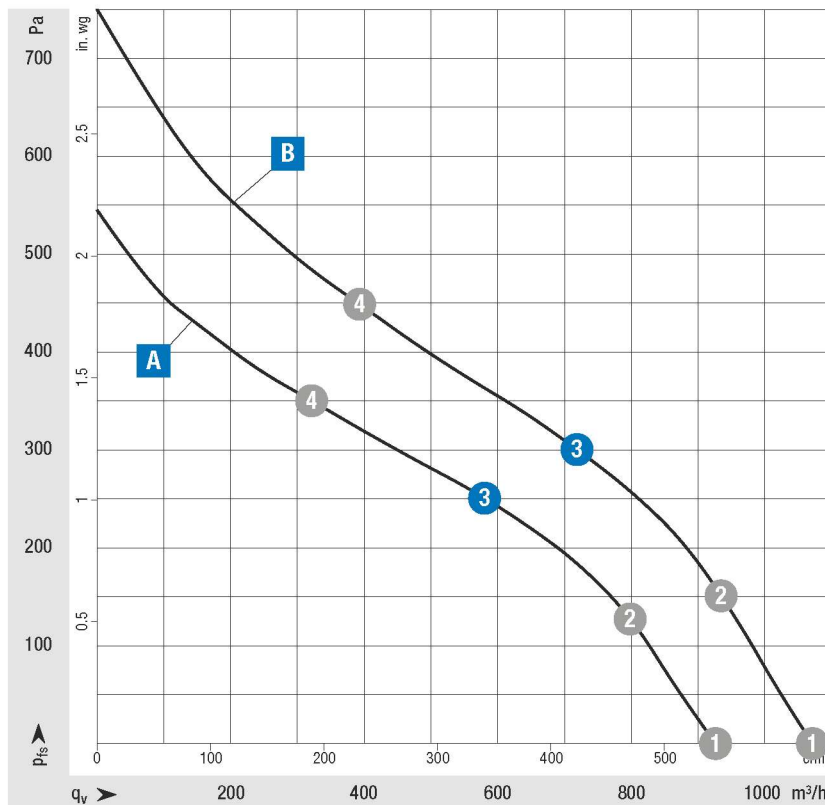

Measuring requirements

Air performance measured according to: ISO 5801, installation category A, with ebm-papst inlet ring without contact protection. Intake-side sound level: L_{pA} according to 13347, L_{pA} measured at 1 m distance from fan axis. The values given are only applicable under the specified measuring conditions and may differ depending on the installation conditions. In the event of deviation from the standard configuration, the parameters must be checked in installed condition.

Curve	Operating point	Nominal voltage	Speed n	Max. Input power P _{ed}	Max. Input current I	Sound power level L _{WA}	Installation position	Perm. ambient temp.	Degree of protection	Insulation class	Conn. diagram
		VDC									
Nominal voltage range 8-16 V DC											
A	1	12	2700	90	8,60	74	Shaft horizontal or rotor on bottom	-25...+60	Motor: IP 24 KM Electronics: IP 66/69 K	B	TR12)
	2	12	2670	92	8,84	71					
	3	12	2600	96	9,25	66					
	4	12	2685	92	8,80	69					
Nominal voltage range 16-28 V DC											
B	1	24	3050	125	5,20	78	Shaft horizontal or rotor on bottom	-25...+60	Motor: IP 24 KM Electronics: IP 66/69 K	B	TR13)
	2	24	3085	131	5,43	75					
	3	24	2965	132	5,50	71					
	4	24	3065	130	5,40	72					

Values set in blue are nominal data at operating point with maximum load.

Subject to change



Curve	BL-DC centrifugal fans		
	Type	Part number	Weight kg
A	VBS0220RUNCS	R1G220RD6103	1,50
B	VBS0220RUNCS	R1G220RD1003	1,50

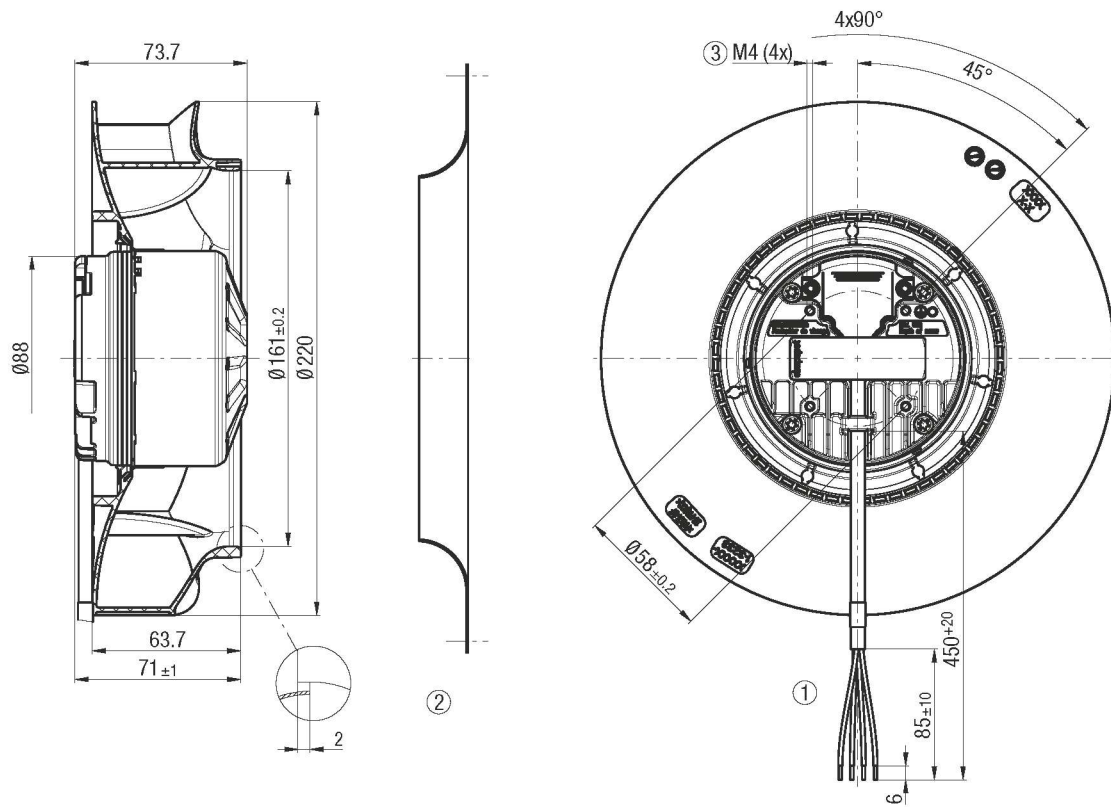

- ① Cable FLRYW 4x 0,75 mm², 4x splice
- ② Accessory part: inlet ring 09609-2-4013 not included in scope of delivery
- ③ Max. clearance for screw 6 mm

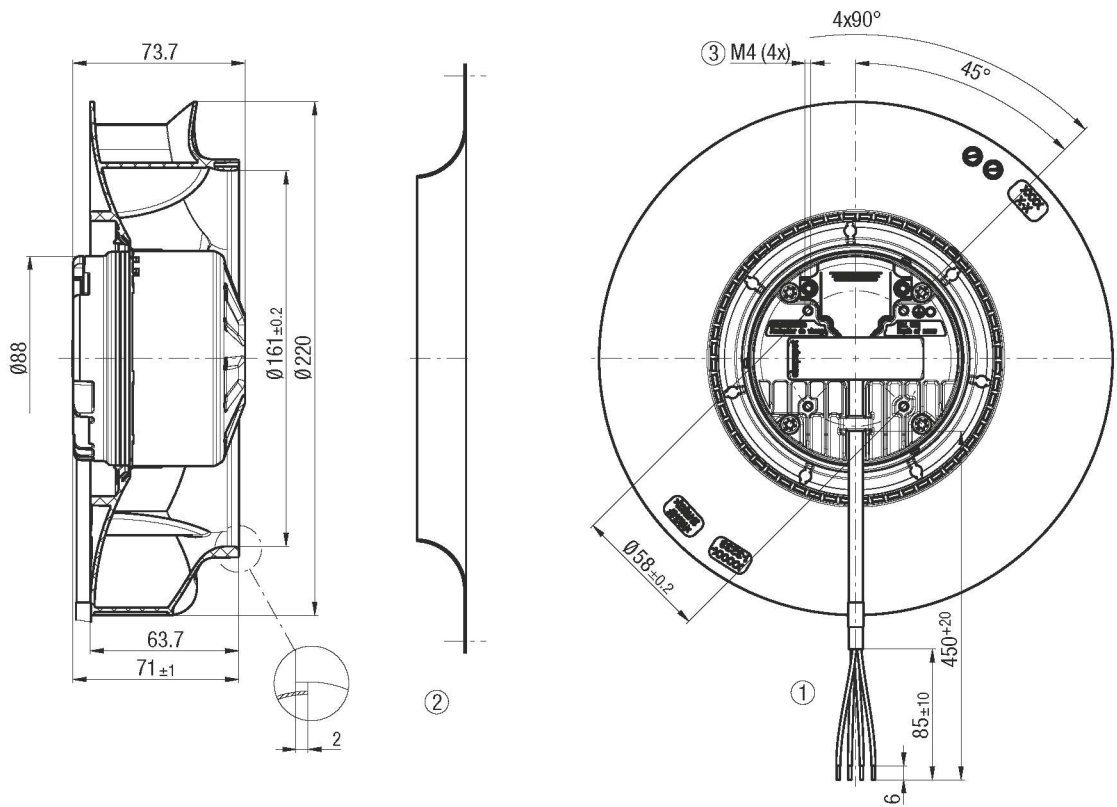

- ① Cable FLRYW 4x 0,75 mm², 4x splice
- ② Accessory part: inlet ring 09609-2-4013 not included in scope of delivery
- ③ Max. clearance for screw 6 mm

BL-DC centrifugal fans - RadiCal

backward curved, for commercial vehicle applications, \varnothing 250 mm



Material/surface

- Impeller: PA plastic
- Rotor surface: Galvanized
- Electronics housing: Die-cast aluminum

Mechanical data

- Direction of rotation: Clockwise viewed toward rotor
- Mode: Continuous operation (S1)
- Mounting: Maintenance-free ball bearings, sealed

Standards and approvals

- Approvals: EAC

on Page 82	Drawings
on Page 88	Accessories
on Page 98	Connection diagrams and technical features
on Page 114	Technical parameters & scope
More at	www.ebmpapst.com

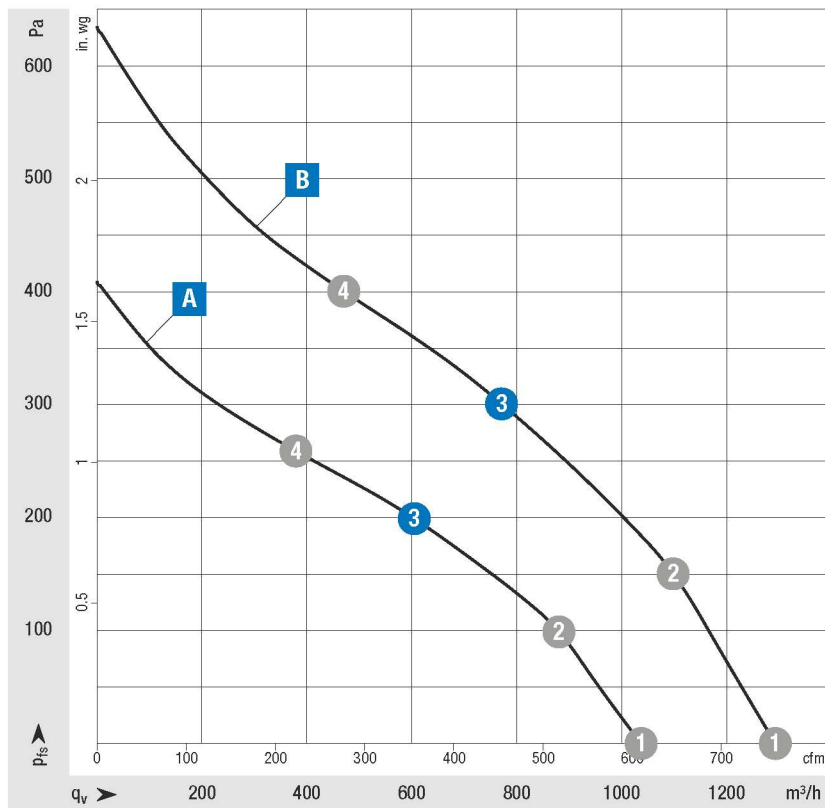

Measuring requirements

Air performance measured according to: ISO 5801, installation category A, with ebm-papst inlet ring without contact protection.
 Intake-side sound level: L_{pA} according to 13347, L_{pA} measured at 1 m distance from fan axis. The values given are only applicable under the specified measuring conditions and may differ depending on the installation conditions. In the event of deviation from the standard configuration, the parameters must be checked in installed condition.

Curve	Operating point	Nominal voltage	Speed n	Max. Input power P _{ed}	Max. Input current I	Sound power level L _{WA}	Installation position	Perm. ambient temp.	Degree of protection	Insulation class	Conn. diagram
		VDC									
Nominal voltage range 8-16 V DC											
A	1	12	2000	64	5,40	70	Shaft horizontal or rotor on bottom	-25...+70	Motor: IP 24 KM Electronics: IP 66/69 K	B	TR12)
	2	12	1945	69	5,69	67					
	3	12	1895	71	5,95	63					
	4	12	1945	69	5,69	66					
Nominal voltage range 16-28 V DC											
B	1	24	2500	120	4,90	75	Shaft horizontal or rotor on bottom	-25...+60	Motor: IP 24 KM Electronics: IP 66/69 K	B	TR13)
	2	24	2420	123	5,14	73					
	3	24	2350	130	5,39	69					
	4	24	2420	124	5,16	71					

Values set in blue are nominal data at operating point with maximum load.

Subject to change

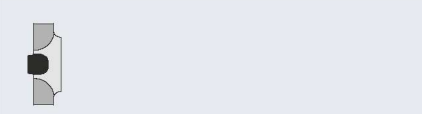

Curve	BL-DC centrifugal fans		
	Type	Part number	Weight kg
A	VBS0250RUNES	R1G250RC7703	2,00
B	VBS0250RUNES	R1G250RC8703	2,00

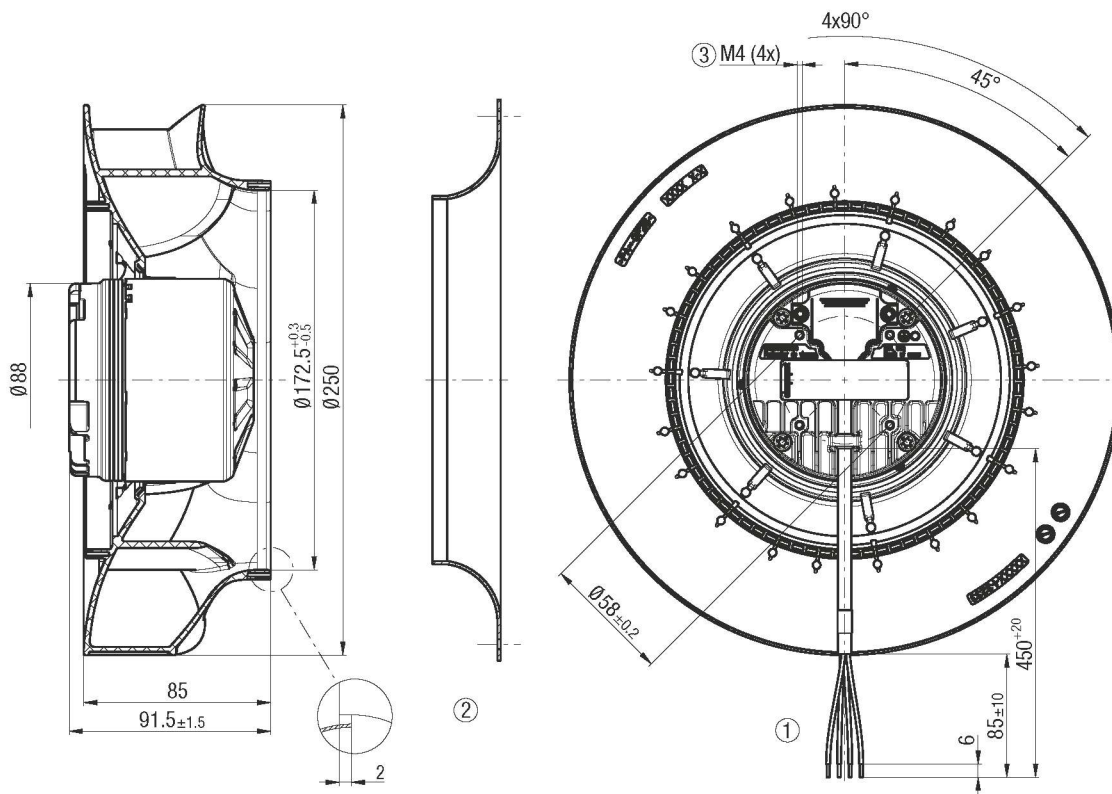

- ① Cable FLRYW 4x 0,75 mm², 4x splice
- ② Accessory part: inlet ring 96359-2-4013 not included in scope of delivery
- ③ Max. clearance for screw 6 mm

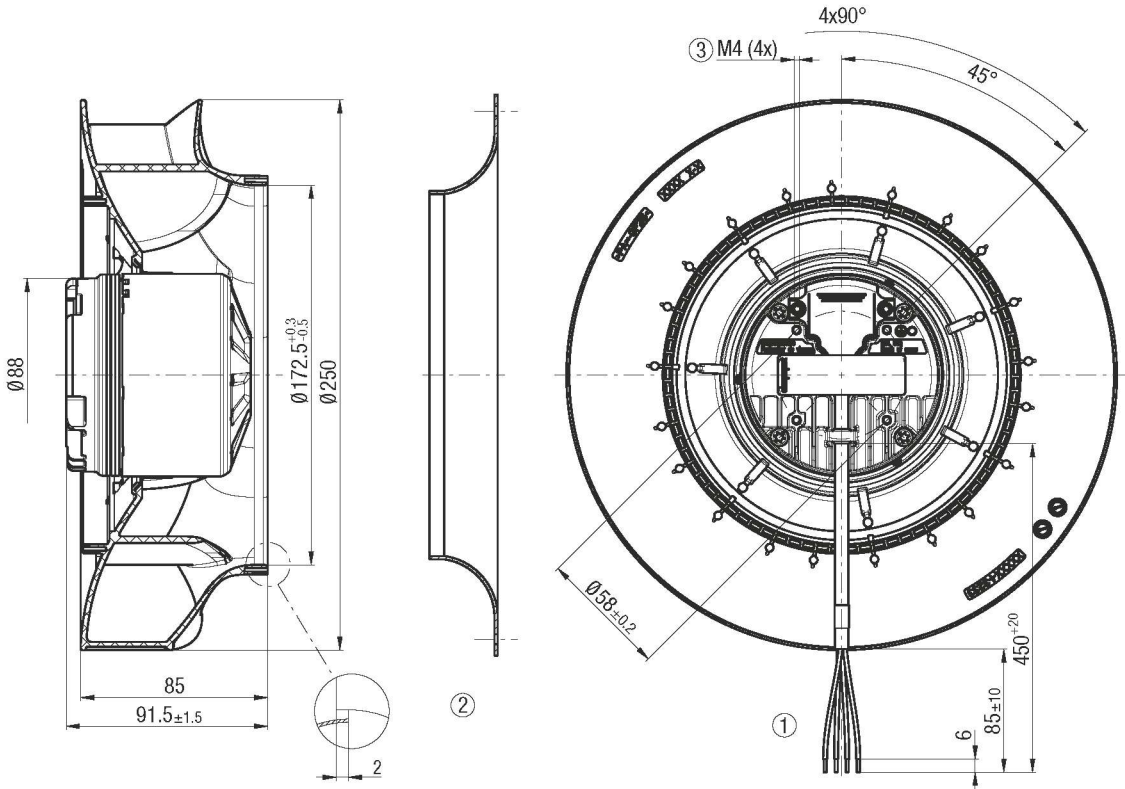

- ① Cable FLRYW 4x 0,75 mm², 4x splice
- ② Accessory part: inlet ring 96359-2-4013 not included in scope of delivery
- ③ Max. clearance for screw 6 mm

BL-DC centrifugal fans - RadiCal

backward curved, for commercial vehicle applications, Ø 280 mm



Material/surface

- Impeller: PA plastic
- Rotor surface: Galvanized
- Electronics housing: Die-cast aluminum

Mechanical data

- Direction of rotation: Clockwise viewed toward rotor
- Mode: Continuous operation (S1)
- Mounting: Maintenance-free ball bearings, sealed

Standards and approvals

- Approvals: EAC

on Page 86	Drawings
on Page 88	Accessories
on Page 98	Connection diagrams and technical features
on Page 114	Technical parameters & scope
More at	www.ebmpapst.com

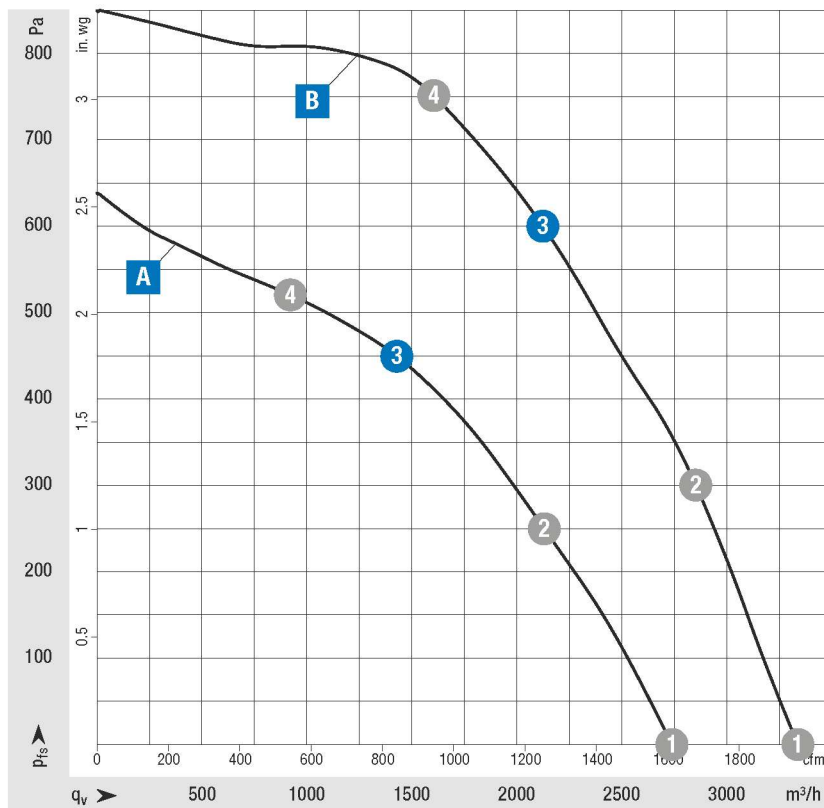

Measuring requirements
 Air performance measured according to: ISO 5801, installation category A, with ebm-papst inlet ring without contact protection.
 Intake-side sound level: L_{pA} according to 13347, L_{pA} measured at 1 m distance from fan axis. The values given are only applicable under the specified measuring conditions and may differ depending on the installation conditions. In the event of deviation from the standard configuration, the parameters must be checked in installed condition.

Curve	Operating point	Nominal voltage		Speed n	Max. Input power P _{ed}	Max. Input current I	Sound power level L _{WA}	Installation position	Perm. ambient temp.	Degree of protection	Insulation class	Conn. diagram
		VDC	rpm									
Nominal voltage range 16-32 V DC												
A	1	26	2350	252	10,5	80	Shaft horizontal or rotor on bottom	-40...+70	Motor: IP 24 KM Electronics: IP 66/69 K	B	TR14)	
	2	26	2280	298	12,4	75						
	3	26	2265	304	12,6	73						
	4	26	2305	280	11,7	74						
B	1	26	2350	252	10,5	80	Shaft horizontal or rotor on bottom	-40...+70	Motor: IP 24 KM Electronics: IP 66/69 K	B	TR15)	
	2	26	2280	298	12,4	75						
	3	26	2265	304	12,6	73						
	4	26	2305	280	11,7	74						

Values set in blue are nominal data at operating point with maximum load.

Subject to change



Curve	BL-DC centrifugal fans		
	Type	Part number	Weight kg
A	VBS0280RUPES	R3G280RU2681	3,00
B	VBS0280RUPES	R3G280RU6582	3,00

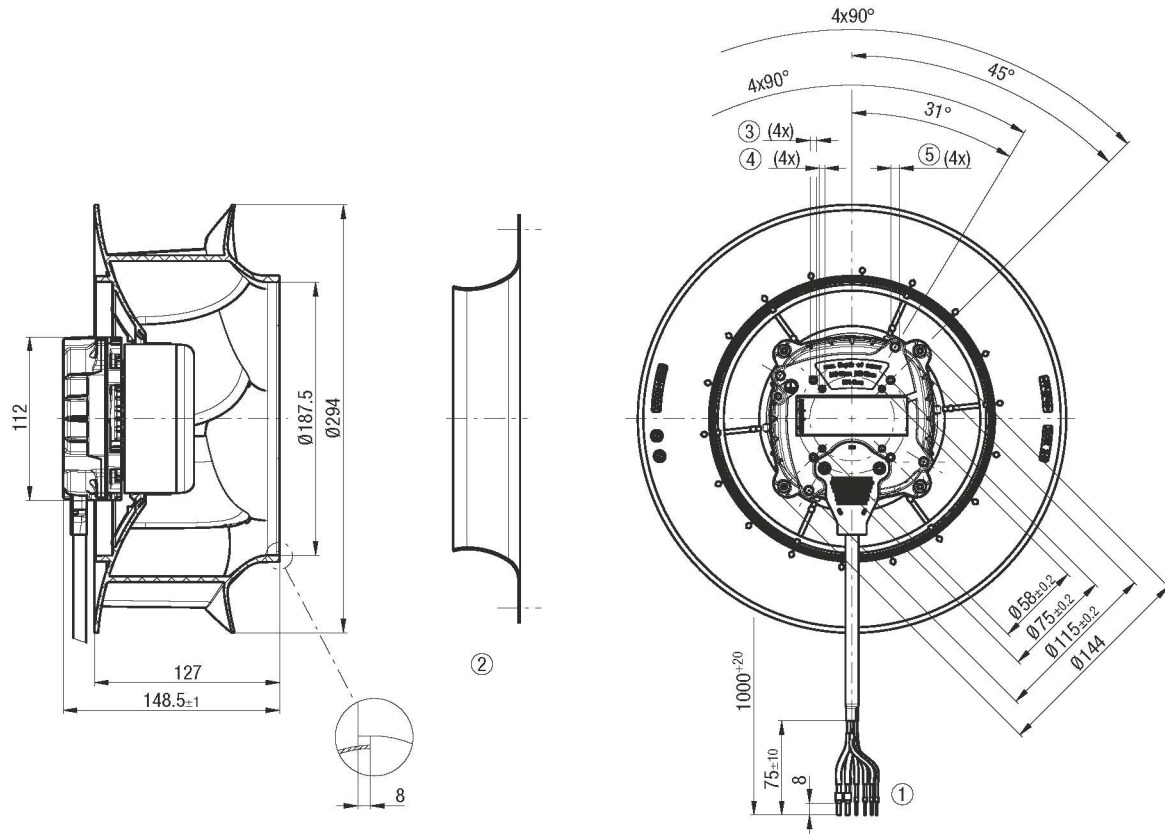

- ① Cable (railway) 2x 2,5 mm², 4x 1,0 mm², 6x crimped ferrules
- ② Accessory part: inlet ring 28000-2-4013 not included in scope of delivery
- ③ Max. clearance for screw 10 mm, tapping hole ready for self-tapping M5 screw
- ④ Max. clearance for screw 8 mm, tapping hole ready for self-tapping M4 screw
- ⑤ Max. clearance for screw 12 mm, tapping hole ready for self-tapping M6 screw

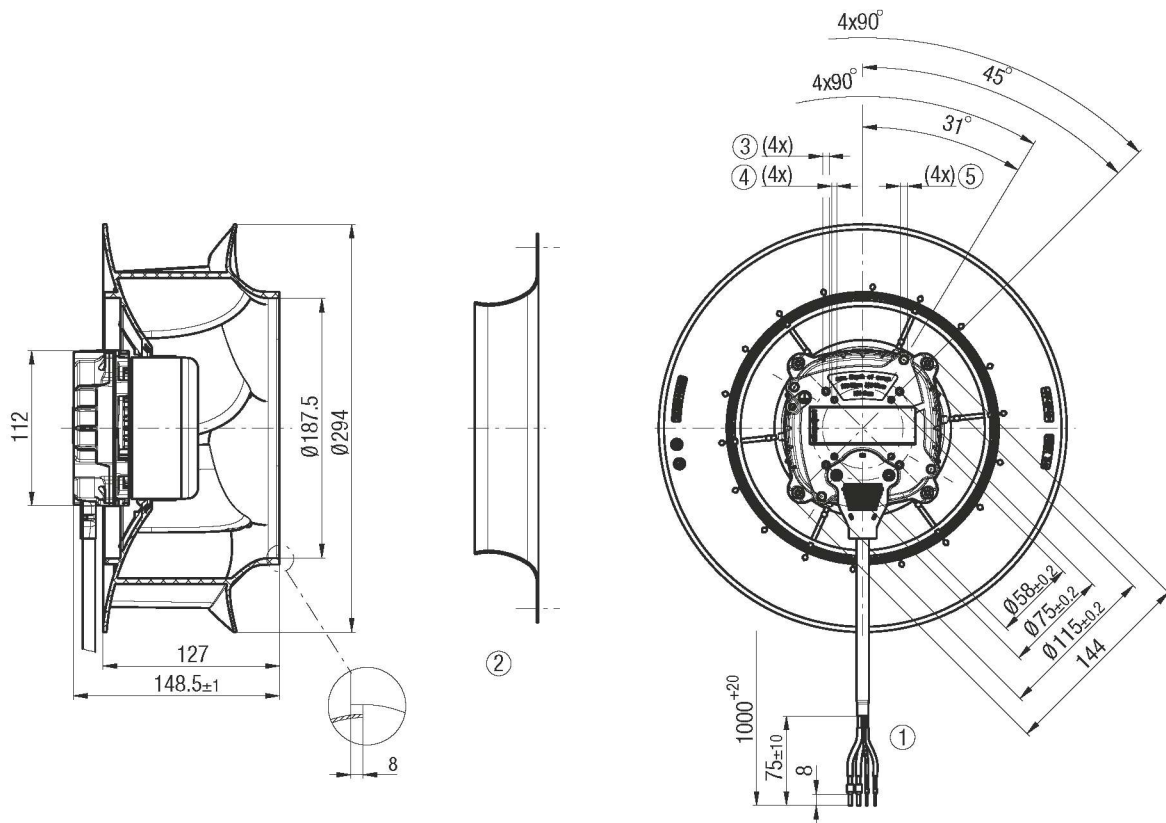

- ① Cable halogen-free, BETAtans® 3 GKW 6 mm², 2x crimped ferrules (brown, black), BETAtans® 3 GKW 1 mm², 2x crimped ferrules (yellow, white)
- ② Accessory part: inlet ring 28000-2-4013 not included in scope of delivery
- ③ Max. clearance for screw 10 mm, tapping hole ready for self-tapping M5 screw
- ④ Max. clearance for screw 8 mm, tapping hole ready for self-tapping M4 screw
- ⑤ Max. clearance for screw 12 mm, tapping hole ready for self-tapping M6 screw



Accessories

for commercial vehicle fans

ebmpapst

the engineer's choice

	Page
Cables	90
Guard grille	92
Inlet rings	94

Cables

for commercial vehicle fans

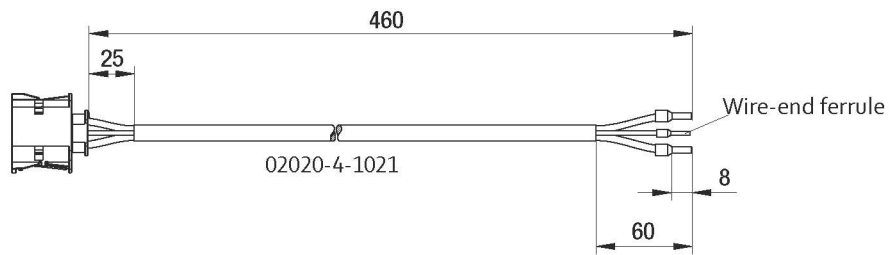
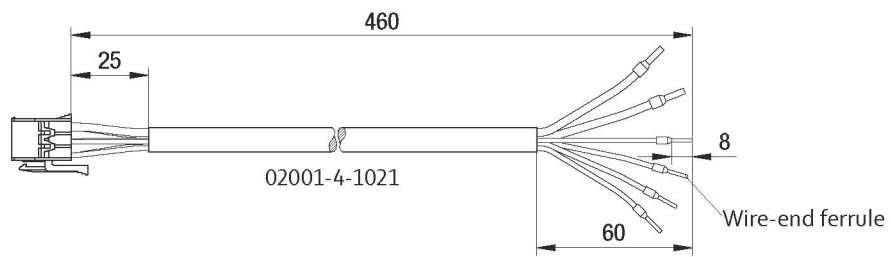

Accessories

Cables

Part number	Application
02001-4-1021	Dual centrifugal fans with housing
02020-4-1021	VWT0300XUNES (W1G300EC)

Subject to change

Cables

for commercial vehicle fans

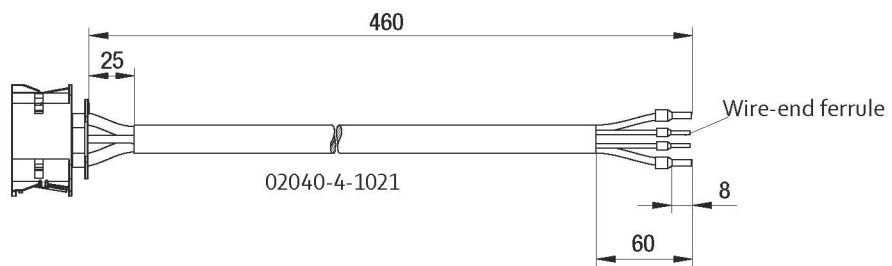
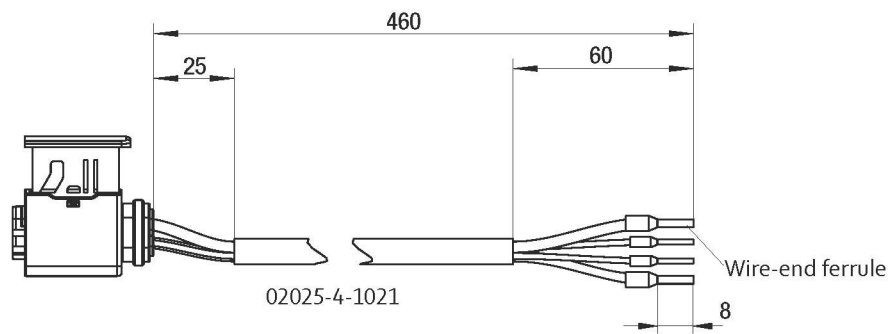

Cables

Part number	Application
02025-4-1021	VWS0250XUNBS (W3G250EC)
02040-4-1021	VFS0146XUPCS (R3G146EC), VWS0300XUPCS (W3G300ME)

Subject to change

Guard grille

for commercial vehicle fans

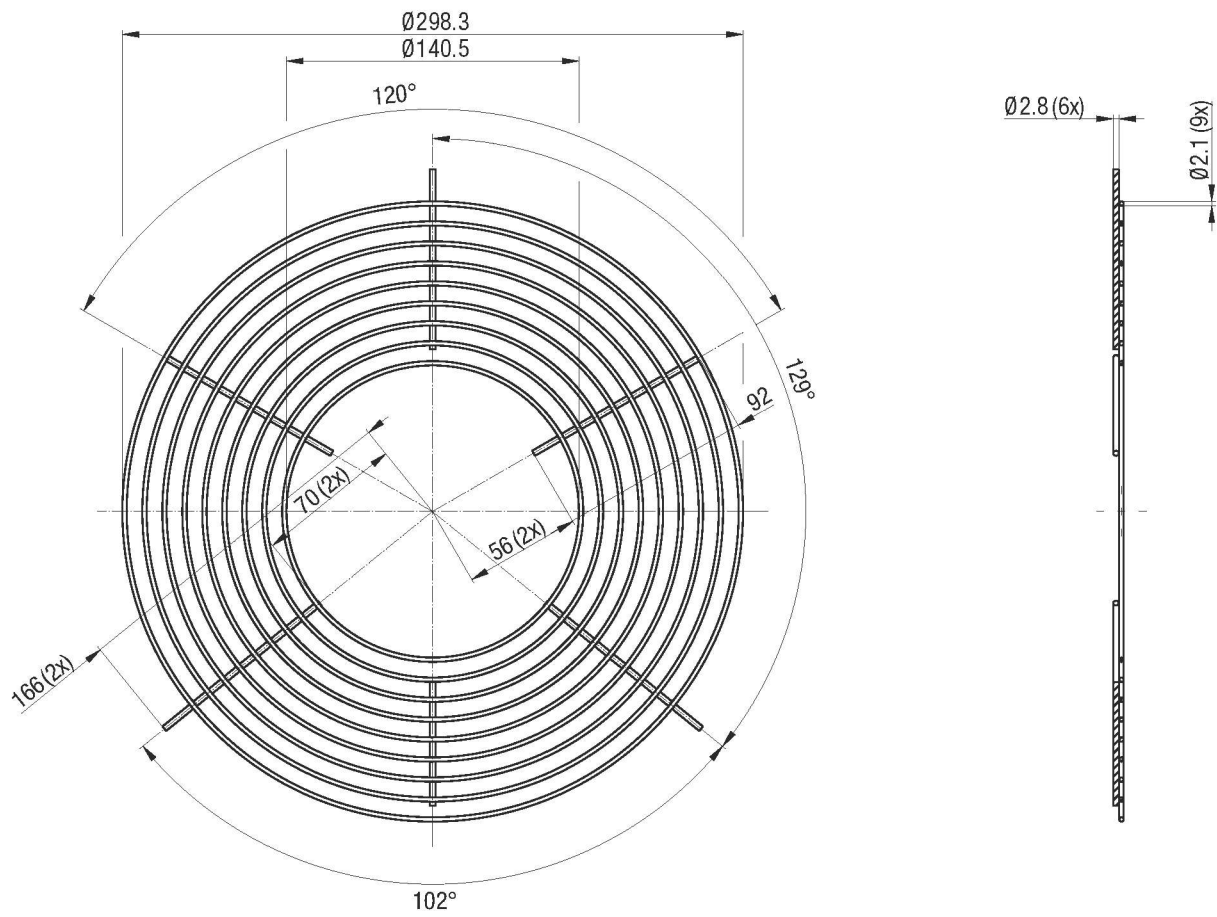

Accessories

Guard grille

Part number	Application
18600-2-4039	VWT0300XUNES (W1G300EC)

Subject to change

Guard grille

for commercial vehicle fans

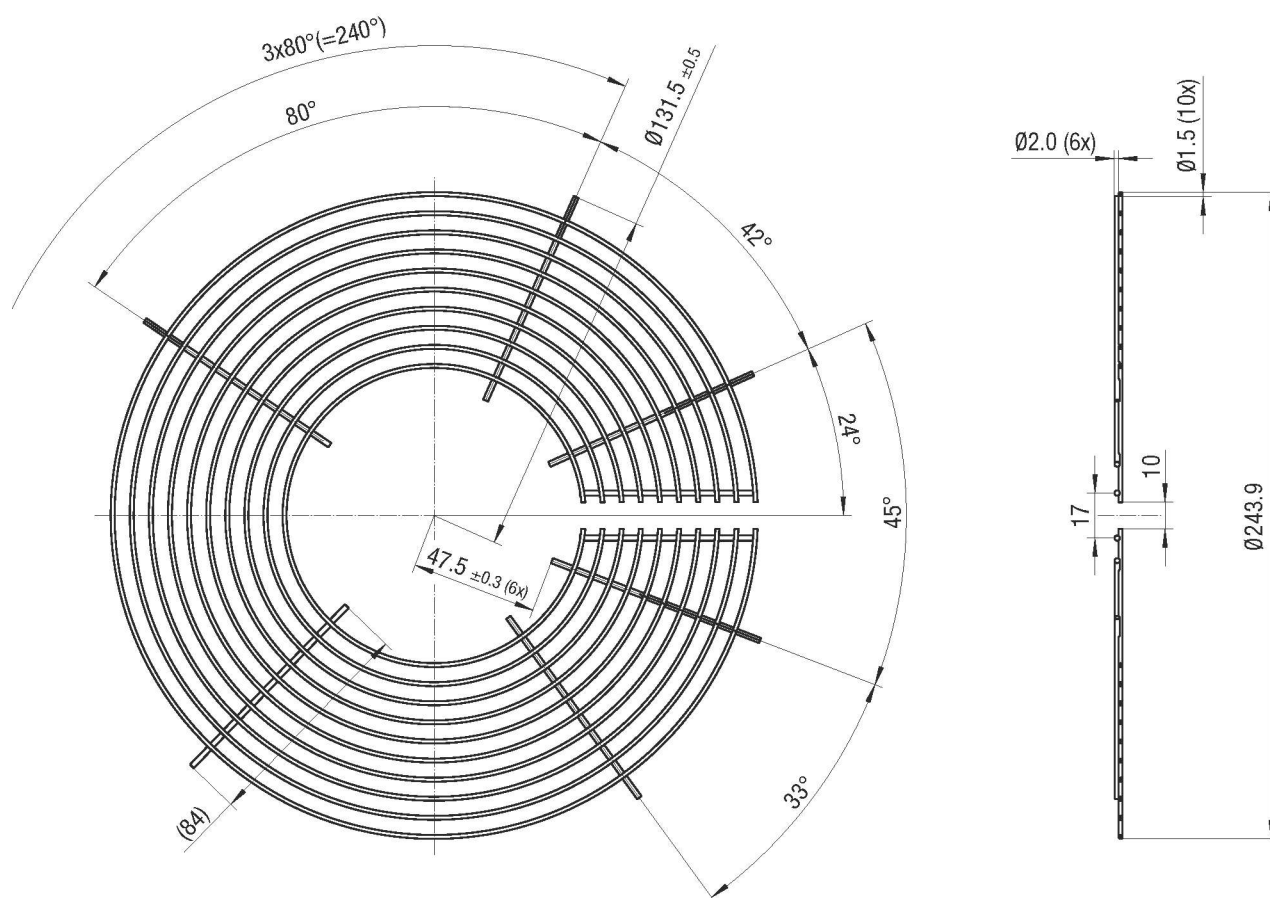

Guard grille

Part number	Application
18605-2-4039	VWS0250XUNBS (W3G250EC)

Subject to change

Inlet rings

for commercial vehicle fans



Fan size 220, RadiCal

Part number

09609-2-4013

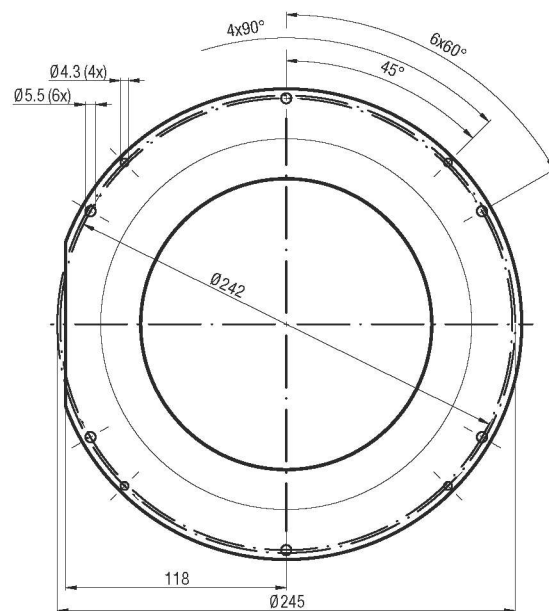
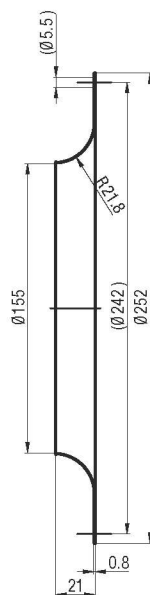

Inlet rings

for commercial vehicle fans

Fan size 250, RadiCal

Part number

96359-2-4013

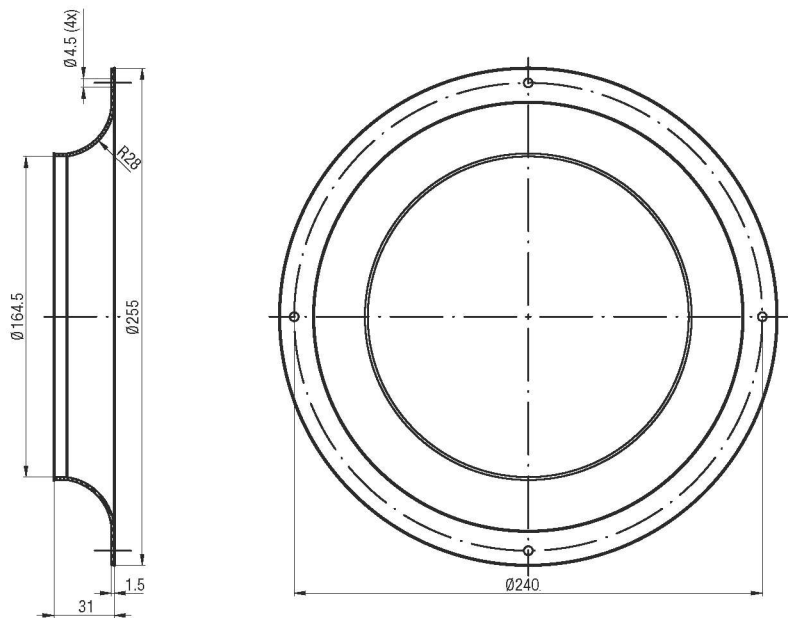

Fan size 280, RadiCal

Part number

28000-2-4013

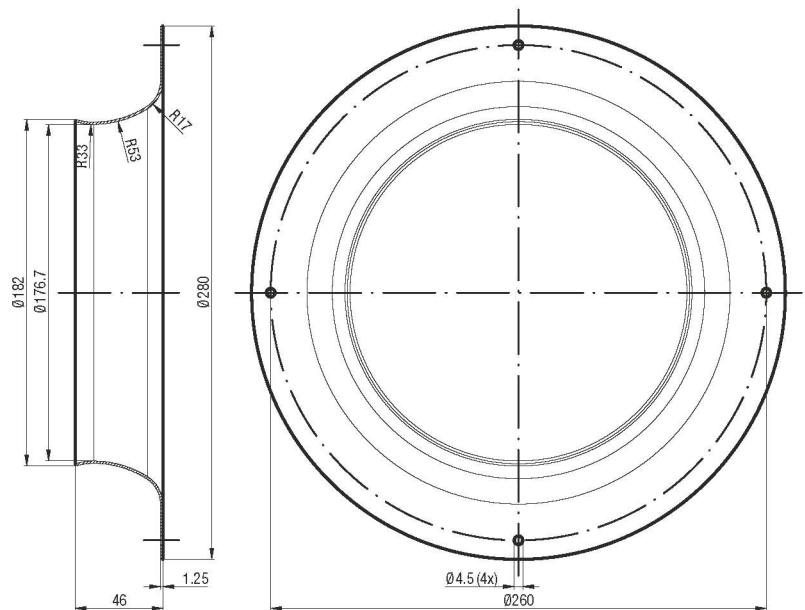

Technology

for commercial vehicle fans

ebmpapst

the engineer's choice

	Page
Connection diagrams	98
Technical parameters & scope	114

Connection diagram: TR1)

Technical features:

- Control input 0-10 VDC / PWM
- Fault output (Open Collector)
- Reverse polarity protection
- Motor current limiter
- Output limit
- Soft start
- Over-temperature protected electronics
- Temperature derating
- Load-Dump (58 V)

Connector



Designation	Assignment / function
DIAG	Diagnostic output: Open Collector, $I_{source\ max} = 10\ mA$, $R_{source} = 2\ k\Omega$; $R_{sink} = 100\ k\Omega$ Fan OK -> low; fan error -> high
0-10 V / PWM	Control input: $R_i > 27\ k\Omega$ 0-10 V: (typ. 0,5 V -> Standby; 1,5 V -> n = min.; 9,5 V -> n = max.) or PWM: (12 V - U_b ; 1 kHz - 10 kHz; typ. < 1 % -> Standby; 10 % -> n = min.; 95 % -> n = max.)
+UB	Power supply +
GND	Power supply -

Connection diagram: TR2)

Technical features:

- Control input 0-10 VDC / PWM
- Temperature derating
- Reverse polarity and locked-rotor protection
- Motor current limiter
- Load-Dump (58V)
- Soft start
- Over-temperature protected electronics

Cable with connector



Designation	Assignment / function
+UB	Power supply +
0-10 V / PWM	Analog voltage control input 0-10 V or PWM
DIAG	Fan OK -> high; fan error -> low; Isink max = 10 mA
GND	Power supply -

Connection diagram: TR3)

Technical features:

- Control input 0-10 VDC / PWM
- Start at 85 °C (2 min) permitted
- Overvoltage detection
- Motor current limiter
- Undervoltage detection
- Soft start
- Over-temperature protected electronics
- Passiver Reverse polarity and locked-rotor protection
- Load-Dump (58 V)

Pin header



Designation	Assignment / function
+ UB	Power supply +
GND	Power supply -
100 %, PWM/LIN	100 % speed, analog voltage control input 0-10 V or PWM
80 %	80 % speed
60 %	60 % speed
NC	Not used / no function

Connection diagram: TR4)

Technical features:

- Control input 0-10 VDC / PWM
- Tach output
- Output limit
- Motor current limiter
- Temperature derating
- Soft start
- Over-temperature protected electronics
- Reverse polarity and locked-rotor protection
- Load-Dump (58 V)

Connector

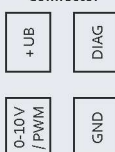

Designation	Assignment / function
+ UB	Power supply +
0-10 V / PWM	Typical values Control input $R_i > 36 \text{ k}\Omega$ 0-10 V: $< 1 \text{ V} \rightarrow n=0$ $1,5 \text{ V} \rightarrow n=\text{min}$ $> 9,5 \text{ V} \rightarrow n=\text{max}$ or PWM ($> 10 \text{ V}$; 1-10 kHz): $< 4 \% \rightarrow n=0$ $10 \% \rightarrow n=\text{min}$ $> 95 \% \rightarrow n=\text{max}$
DIAG	Tach output: open Collector, 1 pulse per revolution, $I_{\text{sink max}} = 10 \text{ mA}$, $R_i = 2,1 \text{ k}\Omega$
GND	Power supply -

Connection diagram: TR5)

Technical features:

- Control input 0-10 VDC / PWM
- Start at 85 °C (2 min) permitted
- Overvoltage detection
- Motor current limiter
- Undervoltage detection
- Soft start
- Over-temperature protected electronics
- Reverse polarity and locked-rotor protection
- Load-Dump (58 V)
- Output limit
- Temperature derating
- Fault output (Highside-Switch max. 30 mA)

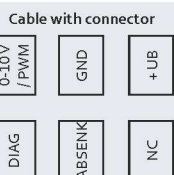

Designation	Assignment / function
0-10 V / PWM	Analog voltage control input 0-10 V or PWM
DIAG	Diagnostic output
GND	Power supply -
ABSENK	Lowering input
+ UB	Power supply +
NC	Not used / no function

Connection diagram: TR6)

Technical features:

- Control input 0-10 VDC / PWM
- Undervoltage detection
- Overvoltage detection
- Motor current limiter
- Soft start
- Over-temperature protected electronics
- Reverse polarity and locked-rotor protection
- Load-Dump (58 V)
- Output limit
- Temperature derating
- Fault output (Highside-Switch max. 30 mA)

Cable with connector

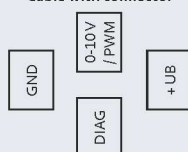

Designation	Assignment / function
+ UB	Power supply + 13VDC
DIAG	Diagnostic output
0-10 V / PWM	Analog voltage control input 0-10 V or PWM
GND	Power supply -

Connection diagram: TR7)

Technical features:

- Control input 0-10 VDC / PWM
- Undervoltage detection
- Overvoltage detection
- Motor current limiter
- Soft start
- Over-temperature protected electronics
- Reverse polarity and locked-rotor protection
- Load-Dump (58 V)
- Output limit
- Temperature derating
- Fault output (Highside-Switch max. 30 mA)

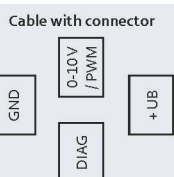

Designation	Assignment / function
+ UB	Power supply + 26VDC
DIAG	Diagnostic output
0-10 V / PWM	Analog voltage control input 0-10 V or PWM
GND	Power supply -

Connection diagram: TR8)

Technical features:

- Control input 0-10 VDC / PWM
- Tach output
- Overvoltage detection
- Motor current limiter
- Undervoltage detection
- Soft start
- Over-temperature protected electronics
- Reverse polarity and locked-rotor protection
- Load-Dump (58 V)
- Output limit
- Temperature derating
- Fault output (Highside-Switch max. 30 mA)
- INVLIN (Control input invers linear)
- Lowering input

Cable with connector



Designation	Assignment / function
0-10 V / PWM	Analog voltage control input 0-10 V or PWM
DIAG	Diagnostic output
GND	Power supply -
ABSENK	Lowering input
+ UB	Power supply + 26VDC
INVLIN	Control input invers linear

Connection diagram: TR9)

Technical features:

- Control input 0-10 VDC / PWM
- Output limit
- Overvoltage detection
- Motor current limiter
- Undervoltage detection
- Soft start
- Over-temperature protected electronics
- Reverse polarity and locked-rotor protection
- Load-Dump (58 V)
- Temperature derating
- Fault output (Highside-Switch)
- Reverse operation (reversal of rotation)

Cable with connector



Designation	Assignment / function
0-10 V / PWM	Control input: $R_i > 42 \text{ k}\Omega$ 0-10 V (typ. $< 1 \text{ V} \rightarrow n = 0$; $1,5 \text{ V} \rightarrow n = \text{min.}$; $10 \text{ V} \rightarrow n = \text{max.}$), potentiometer (limit voltage at potentiometer with 12 V Z-diode) or PWM ($> 12 \text{ V}$; 10-50 kHz; typ. $< 2\% \rightarrow n = 0$; $5\% \rightarrow n = \text{min.}$; $100\% \rightarrow n = \text{max.}$)
DIAG	Diagnostic output: $R_i = 0,05 \text{ k}\Omega$ output level in nominal operation \rightarrow Low
GND	Power supply -
Reverse	Reversal of rotation input: Reverse connected with + UB = Reverse ($R_i = 47 \text{ k}\Omega$) direction of rotation is switched over or open \rightarrow reversal of rotation inactive
+ UB	Power supply +
NC	Not used / no function

Connection diagram: TR10)

Technical features:

- Control input 0-10 VDC
- Temperature derating
- Locked-rotor protection
- Motor current limiter
- Soft start
- Over-temperature protected electronics

Connector



Designation	Assignment / function
+UB	Power supply + 13 VDC, maximum ripple 3,5 %
0-10 VDC	Control input, 2 speed levels
GND	Power supply -

Connection diagram: TR11)

Technical features:

- Control input 0-10 VDC
- Temperature derating
- Locked-rotor protection
- Motor current limiter
- Soft start
- Over-temperature protected electronics
- Start at 85 °C (2 min) permitted

Connector



Designation	Assignment / function
+UB	Power supply + 24 VDC, maximum ripple 3,5 %
0-10 VDC	Control input 0-10 V
GND	Power supply -

Connection diagram: TR12)

Technical features:

- Control input 0-10 VDC / PWM
- Overvoltage detection
- Reverse polarity protection
- Motor current limiter
- Tach output
- Soft start

Cable

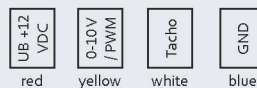

Designation	Color	Assignment / function
UB +12VDC	red	Power supply 12 VDC, maximum ripple 3,5 %
0-10 V / PWM	yellow	Control input $R_e > 40\text{ k}$ (PWM 1-10 kHz / 0-10 V)
Tacho	white	Tach output, 3 pulses per revolution, $I_{\text{sink max}} = 10\text{ mA}$
GND	blue	Power supply -

Connection diagram: TR13)

Technical features:

- Control input 0-10 VDC / PWM
- Overvoltage detection
- Reverse polarity protection
- Motor current limiter
- Tach output
- Soft start
- Over-temperature protected electronics

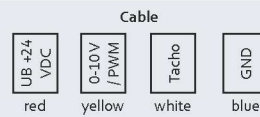

Designation	Color	Assignment / function
UB +24 VDC	red	Power supply 24 VDC, maximum ripple 3,5 %
0-10 V / PWM	yellow	Control input $R_e > 40\text{ k}$
Tacho	white	Tach output, 3 pulses per revolution, $I_{\text{sink max}} = 10\text{ mA}$
GND	blue	Power supply -

Connection diagram: TR14)

Technical features:

- Control input 0-10 VDC / PWM
- Temperature derating
- Overvoltage detection
- Motor current limiter
- Undervoltage detection
- Soft start
- Over-temperature protected electronics
- Reverse polarity protection
- Load-Dump (58 V)
- Output limit
- Fault output (Highside-Switch)
- INVLIN (Control input invers linear)
- Lowering input

Cable

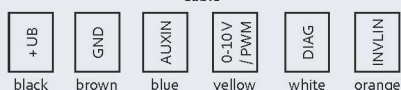

Designation	Color	Assignment / function
+ UB	black	Power supply +
GND	brown	Power supply -
AUXIN	blue	Digital input: when active (> 4 V), value of PWM signal is halved
0-10 V / PWM	yellow	Control input: $R_i > 47 \text{ k}\Omega$ 0-10 V (typ. < 1 V -> n=0; 1,5 V -> n=min; > 10 V -> n=max) PWM (amplitude 10 V; 1-50 kHz; typ. < 5 % -> n=0; 15 % -> n=min; > 100 % -> n=max)
DIAG	white	Diagnostic output: open Collector, $I_{\text{sink max}} = 10 \text{ mA}$, $R_i > 50 \Omega$ Fan OK -> low; fan error -> high
INVLIN	orange	Control input invers linear

Connection diagram: TR15)

Technical features:

- Control input 0-10 VDC / PWM
- Temperature derating
- Overvoltage detection
- Motor current limiter
- Undervoltage detection
- Soft start
- Over-temperature protected electronics
- Reverse polarity protection
- Load-Dump (58 V)
- Standstill in the case of open circuit
- Fault output (Highside-Switch max. 30 mA)
- Start at 85 °C (2 min) permitted

Cable



Designation	Color	Assignment / function
+ UB	black	Power supply +
GND	brown	Power supply -
DIAG	white	Diagnostic output: open Collector, Isink max = 10 mA, Ri > 2,1 kΩ Fan OK -> high; fan error -> low
0-10 V / PWM	yellow	Control input: Ri > 47 kΩ 0-10 V (typ. < 1 V -> n=0; 1,5 V -> n=min; > 10 V -> n=max) PWM (amplitude 10 V; 1-50 kHz; typ. < 5 % -> n=0; 15 % -> n=min; > 100 % -> n=max)



Technical parameters & scope

High standards for all ebm-papst products

Here at ebm-papst, we constantly strive to further improve our products in order to be able to offer you the best possible product for your application. Careful monitoring of the market ensures that technical innovations are reflected in the improvements of our products. Based on the technical parameters listed below and the ambience you want our product to operate in, we here at ebm-papst can always work out the best solution for your specific application.

General performance parameters

Any deviations from the technical data and parameters described here are listed on the product-specific data sheet.

Degree of protection

The type of protection is specified in the product-specific data sheets.

Insulation class

The insulation class is specified in the product-specific data sheets.

Installation position

The mounting position is specified in the product-specific data sheets.

Condensate discharge holes

Information on the condensate discharge holes is provided in the product-specific data sheets.

Mode of operation

The mode of operation is specified in the product-specific data sheets.

Protection class

The protection class is specified in the product-specific data sheets.

Tightening torques for fan assembly

Please consult your ebm-papst contact for questions about which tightening torque to use.

Service life

The service life of ebm-papst products for commercial vehicles depends on the service life of the bearing system. The service life of the bearing system depends mainly on the thermal load on the bearing.

The majority of our products use maintenance-free ball bearings for any mounting position possible.

The service life L10 of the ball bearings can be taken as approx. 40,000 operating hours at an ambient temperature of 40 °C, yet this estimate can vary according to the actual ambient conditions. We will gladly provide you with a lifetime calculation taking into account your specific operating conditions.

Motor protection / thermal protection

Information on motor protection and thermal protection is provided in the product-specific data sheets.

Depending on motor type and field of application, the following protective features are realised:

- Thermal overload protector, connected
- PTC/NTC with electronic evaluation
- Current limiting using electronics

Mechanical strain / performance parameters

All ebm-papst products are subjected to comprehensive tests complying with the normative specifications. In addition to this, the tests also reflect the vast experience and expertise of ebm-papst.

High voltage and insulation testing

If high voltage or insulation testing is carried out in the application, then all connection lines from the fan must be disconnected in advance.

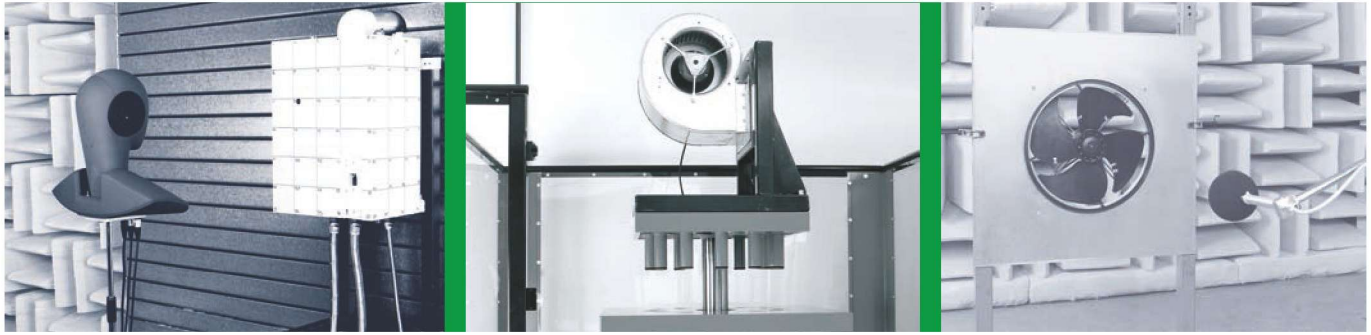

Balancing quality

Balancing grade is tested according to the application's specifications. Residual imbalance is evaluated as specified in DIN ISO 1940 or ISO 14694.

Should you require a higher balancing quality level for your specific application, please let us know and specify this when ordering your product.

Chemo-physical strain / performance parameters

Should you have questions about chemo-physical strain, please direct them to your ebm-papst contact.

Fields of application, industries and applications

Our products are used in a variety of industries and applications. Our fans help to keep the traveling temperature in trucks, trains, buses, and motor homes within a comfortable range – reliably and efficiently.

As a result, drivers and passengers benefit from perfectly controllable air conditioning that makes everyday life at work more pleasant. In the vehicle engine cooling and transport chilling sectors, our products set the benchmark.

Legal and normative directives

The products described in this catalogue are designed, developed and produced in keeping with the standards in place for the relevant product and, if known, the conditions governing the relevant fields of application.

Standards

Information on standards is provided in the product-specific data sheets.

EMC

Information on EMC standards is provided in the product-specific data sheets. Complying with the EMC standards has to be established on the final appliance, as different mounting situations can result in changed EMC properties.

Approvals

In case you require a specific approval for your ebm-papst product (e1, UL, etc.) please let us know.

Most of our products can be supplied with the relevant approval. Information on existing approvals is provided in the product-specific data sheets.

Air performance measurements

All air performance measurements are carried out on suction side and on chamber test beds conforming to the specifications as per ISO 5801 and DIN 24163. The fans under test are installed in the measuring chamber at free air intake and exhaust (installation category A) and are operated at nominal voltage, with AC also at nominal frequency, and without any additional components such as guard grilles.

As required by the standard, the air performance curves correspond to an air density of 1.15 kg/m³.

Technical parameters & scope

Measurement conditions for air and noise measurement

ebm-papst products are measured under the following conditions:

- Axial and diagonal fans in direction of rotation "V" in full nozzle and without guard grill
- Backward curved centrifugal fans, free-running and with inlet nozzle
- Forward curved single and dual inlet centrifugal fans with housing

Noise measurements

All noise measurements are carried out in low-reflective test rooms with reverberant floor. Thus the ebm-papst acoustic test chambers meet the requirements of precision class 1 according to DIN EN ISO 3745. For noise measurement, the fans being tested are placed in a reverberant wall and operated at nominal voltage (for AC, also at nominal frequency) without additional attachments such as the guard grill.

Sound pressure level and sound level

All acoustic values are established according to ISO 13347, DIN 45635 and ISO 3744/3745 to accuracy class 2 and given in A-rated form.

When the sound pressure level (L_p) is measured, the microphone is on the intake side of the fan being tested, usually at a distance of 1 m on the fan axis.

To measure the sound power level (L_w) 10 microphones are distributed over an enveloping surface on the intake side of the fan being tested (see graphic). The sound power level measured can be roughly calculated from the sound pressure level by adding 7 dB.

Measuring configuration as per ISO 13347-3 bzw. DIN 45635-38:

- 10 measuring points

$d \geq D$

$h = 1,5d \dots 4,5d$

Measurement area $S = 6d^2 + 7d(h + 1,5d)$

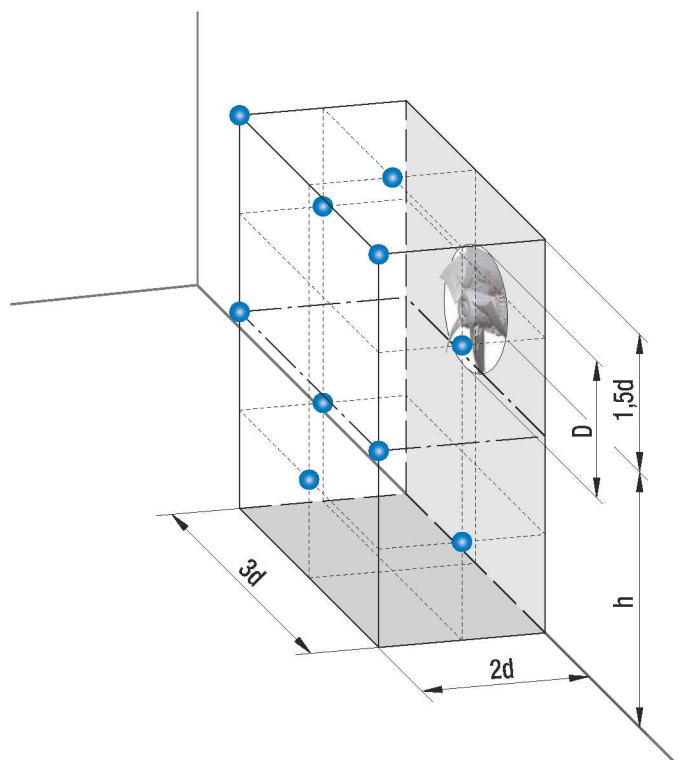

Combined level of multiple same-level sound sources

Adding 2 noise sources with the same level results in a level increase of approx. 3 dB.

The noise characteristics of multiple identical fans can be determined in advance based on the noise values specified in the data sheet. This is shown in the diagram opposite.

Example: 8 A3G800 axial fans are on a condenser. According to the data sheet, the sound pressure level of a fan is approximately 75 dB(A). The level increase measured from the diagram is 9 dB. Thus the overall sound level of the installation can be expected to be 84 dB(A).

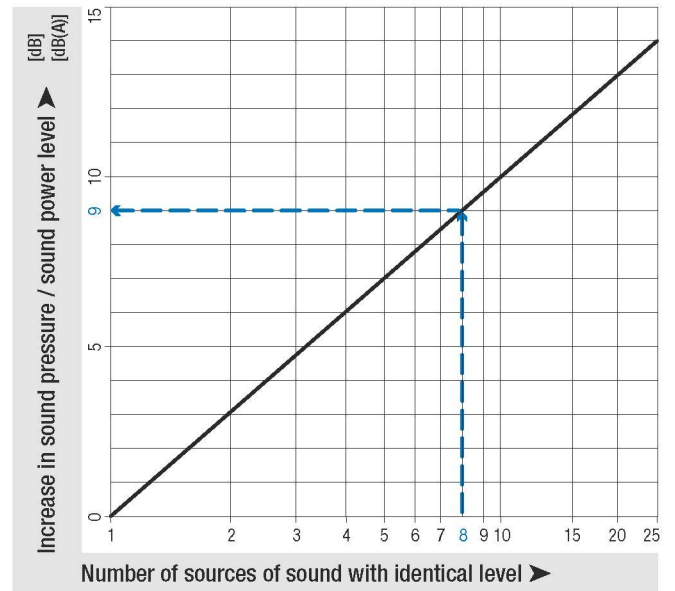

Combined level of two different-level sound sources

The acoustic performance of two different fans can be predetermined based on the sound levels given in the data sheet. This is shown in the diagram opposite.

Example: There is an axial fan A3G800 with a sound pressure level of 75 dB(A) at the operating point and an axial fan A3G710 with 71 dB(A) in a ventilation unit. The level difference is 4 dB. The level increase can now be read in the diagram as approx. 1.5 dB. This means that the overall sound level of the unit can be expected to be 76.5 dB(A).

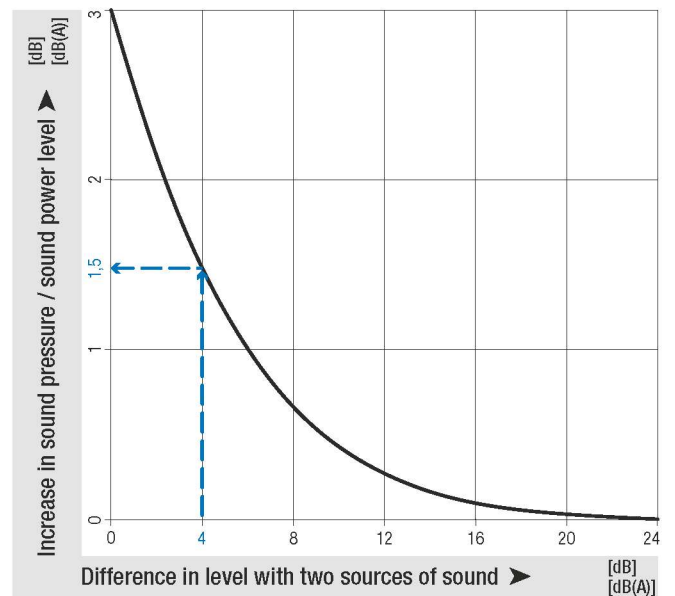

Distance laws

Sound power level is independent of distance to the sound source. In contrast to this, sound pressure level decreases the further away the noise source is. The adjacent diagram shows the decrease in level under far sound field conditions. Far sound field conditions apply whenever the distance between microphone and fan is big when compared to fan diameter and wavelength to be considered. For more information on far sound field, please consult the relevant literature on this complex topic. Per doubling of distance, the level in the far sound field decreases by 6 dB. In the near field of the fan, other correlations apply and the decrease in levels can be considerably smaller. The following example only applies to far sound field conditions and can vary strongly depending on the installation effects: With an axial fan A3G300, a sound pressure level of 65 dB(A) was measured at a distance of 1 m. According to the adjacent diagram, at a distance of 20 m we would get a reduction by 26 dB, i.e. a sound pressure level of 39 dB(A).

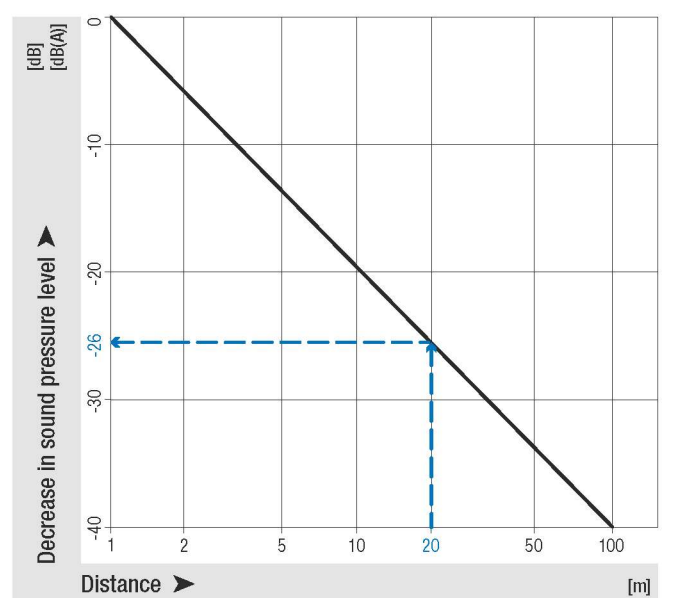

Technical parameters & scope

Aerodynamics fundamentals:

Further information can be found in our brochure "Technology - Basic principles"

Axial fan operating range:

To the right of the saddle point (right section of the air performance curve):

- Maximum efficiency
- Minimum noise

To the left of the saddle point (left section of the air performance curve):

- Stall
- Irruptive efficiency
- Noise suddenly increases

The fan's optimal range of use is highlighted in green in the adjoining performance curve.

Effects of guard grill:

Installing a guard grill reduces the axial fan's air performance.

The pressure loss in Pa can be roughly calculated using the following equation:

$$\Delta p_{SG} = \epsilon_{SG} \cdot 10^{-8} \cdot \dot{V}^2 \quad \dot{V} \text{ in } [m^3/h]$$

For the guard grill that ebm-papst used, the correction factor ϵ_{SG} dependent on impeller diameter D can be found in the adjoining table.

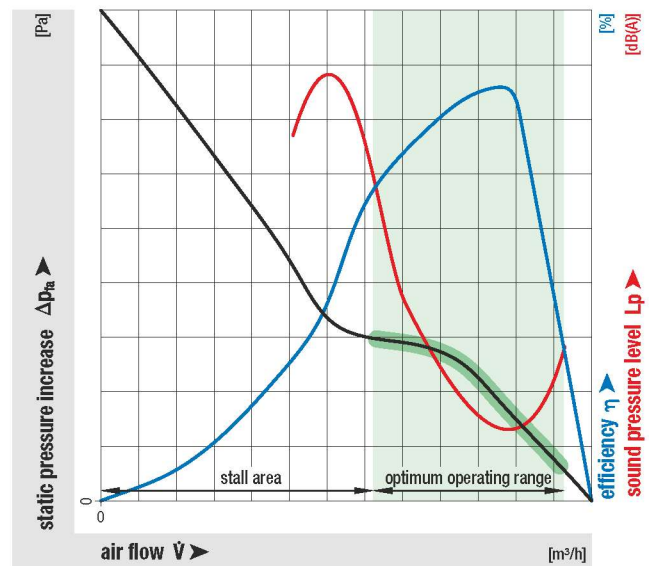

Diameter D	Correction factor ϵ_{SG}
400	90
450	55
500	35

Centrifugal fan operating range:

Middle section of the air performance curve:

- Maximum efficiency
- Minimum noise

To the left and right of the middle section of the air performance curve:

- Reduced efficiency
- Increasing noise

The fan's optimal range of use is highlighted in green in the adjoining performance curve.

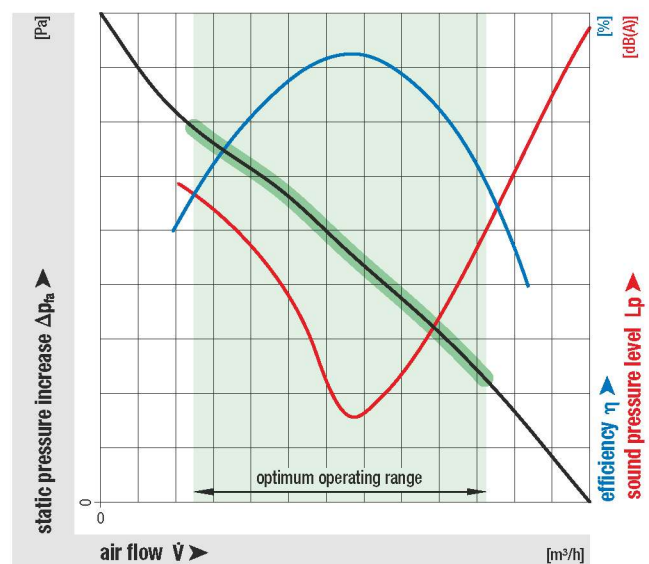

Effects of installation space

Installation in a square box may cause a reduction of the air performance.

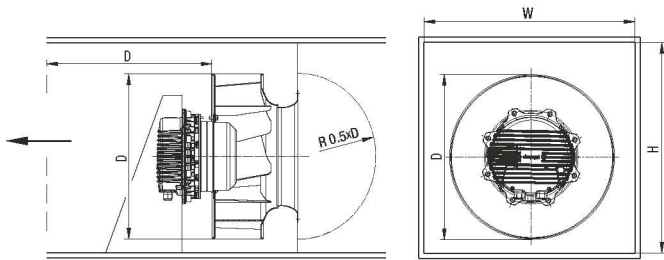

- d_h = hydraulic diameter
Formula: $d_h = 2 \times W \times H / (W + H)$
- W = Width of the box
- H = Height of the box
- D = Outside diameter of the fan

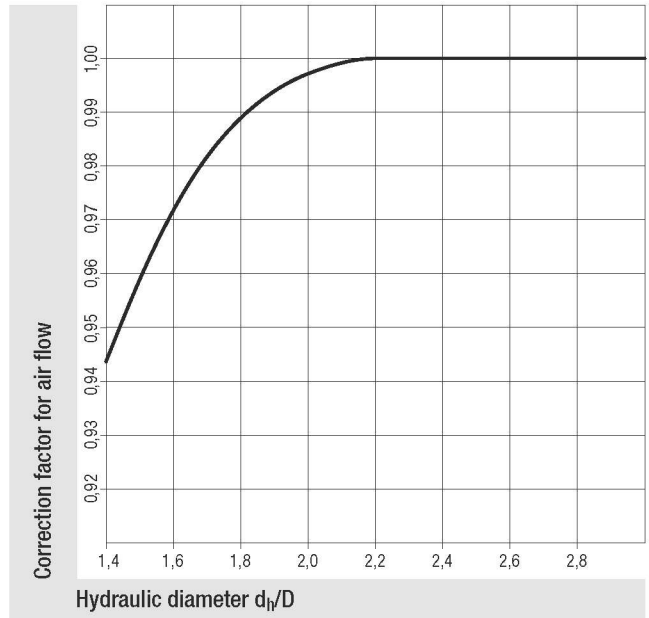

Airflow determination for inlet rings with pressure tap:

The differential pressure method compares the static pressure upstream of the inlet ring with the static pressure in the inlet ring. The airflow can be calculated from the differential pressure (between the static pressures) according to the following equation:

$$q_V = k \cdot \sqrt{\Delta p} \quad q_V \text{ in [m}^3/\text{h]} \text{ and } \Delta p \text{ in [Pa]}$$

If the airflow is to be regulated to remain constant, the inlet pressure must be kept constant:

$$\Delta p = q_V^2 : k^2$$

k takes the specific properties of the inlet ring into account.

The pressure is tapped at 1 (4) point(s) on the circumference of the inlet ring. The customer connection consists of a built-in T-shaped hose fitting. The hose fitting is suitable for pneumatic hoses with an inside diameter of 4 mm.

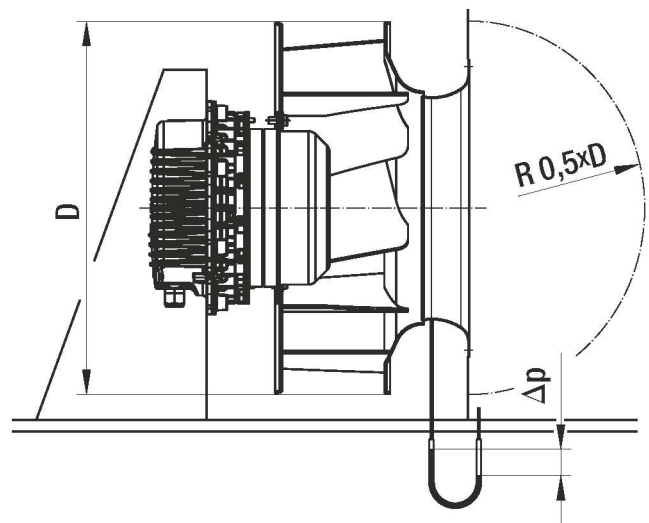

Influence of Speed n on the sound power level L_w :

The sound power level for changes in speed can be approximately determined based on the adjoining diagram and the following formula:

$$L_{w2} - L_{w1} = 50 \text{ dB} \cdot \log(n_2 : n_1)$$

- L_{w1} = Sound power level after speed change
- L_{w2} = Sound power level before speed change
- n_1 = Changed speed
- n_2 = Initial speed

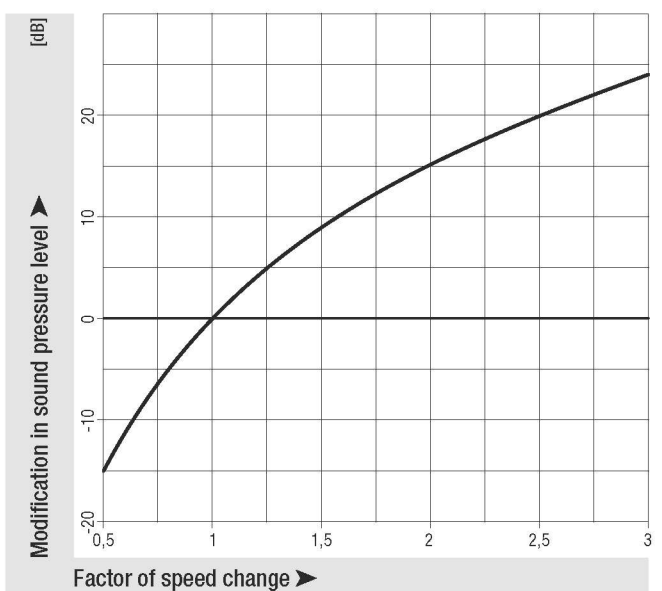

ebm-papst Mulfingen GmbH & Co. KG

Bachmühle 2
74673 Mulfingen
GERMANY
Phone +49 7938 81-0
Fax +49 7938 81-110
info1@de.ebmpapst.com



ebm-papst St. Georgen GmbH & Co. KG

Hermann-Papst-Straße 1
78112 St. Georgen
GERMANY
Phone +49 7724 81-0
Fax +49 7724 81-1309
info2@de.ebmpapst.com



ebm-papst Landshut GmbH

Hofmark-Aich-Straße 25
84030 Landshut
GERMANY
Phone +49 871 707-0
Fax +49 871 707-465
info3@de.ebmpapst.com



Agents Worldwide

ebmpapst

the engineer's choice

	Page
ebm-papst in Germany	122
ebm-papst in Europe	123
ebm-papst in America and Africa	125
ebm-papst in Asia	126
ebm-papst in Oceania	127



ebm-papst in Germany

 **Berlin**
 Dipl.-Ing. (TH) Jens Duchow
 Händelstraße 7
 16341 Panketal
 GERMANY
 Phone +49 30 944149-62
 Fax +49 30 944149-63
 Jens.Duchow@de.ebmpapst.com

 **Bielefeld**
 Dipl.-Ing. (FH) Wolf-Jürgen Weber
 Niehausweg 13
 33739 Bielefeld
 GERMANY
 Phone +49 5206 91732-31
 Fax +49 5206 91732-35
 Wolf-Juergen.Weber@de.ebmpapst.com

 **Dortmund**
 Dipl.-Ing. (FH) Hans-Joachim Pundt
 Auf den Steinern 3
 59519 Möhnesee-Völlinghausen
 GERMANY
 Phone +49 2925 800-407
 Fax +49 2925 800-408
 Hans-Joachim.Pundt@de.ebmpapst.com

 **Frankfurt**
 Dipl.-Ing. Christian Kleffmann
 Dr.-Hermann-Krause-Straße 23
 63452 Hanau
 GERMANY
 Phone +49 6181 1898-12
 Fax +49 6181 1898-13
 Christian.Kleffmann@de.ebmpapst.com

 **Halle**
 Dipl.-Ing. (TU) Michael Hanning
 Lercheneck 4
 06198 Salzdahl / OT Lieskau
 GERMANY
 Phone +49 345 55124-56
 Fax +49 345 55124-57
 Michael.Hanning@de.ebmpapst.com

 **Hamburg**
 Ingenieurbüro Breuell GmbH
 Ing. Dirk Kahl
 Elektroingenieur
 Oststraße 96
 22844 Norderstedt
 GERMANY
 Phone +49 40 538092-19
 Fax +49 40 538092-84
 Kahl@breuell-hilgenfeldt.de

 **Heilbronn / Heidelberg**
 Wolfgang Richter
 Büttelsbergweg 18
 97980 Bad Mergentheim-Rengershausen
 GERMANY
 Phone +49 7937 32200-33
 Fax +49 7938 81-110
 Wolfgang.Richter@de.ebmpapst.com

 **Kassel**
 Dipl.-Ing. (FH) Ralph Brück
 Hoherainstraße 3 b
 35075 Gladenbach
 GERMANY
 Phone +49 6462 4071-10
 Fax +49 6462 4071-11
 Ralph.Brueck@de.ebmpapst.com

 **Koblenz**
 Winfried Schaefer
 Hinter der Kirch 10
 56767 Uersfeld
 GERMANY
 Phone +49 2657 16-96
 Fax +49 2657 16-76
 Winfried.Schaefer@de.ebmpapst.com

 **Munich**
 Dipl.-Wirt.-Ing. (FH) Jens Peter
 Schelmenäcker 14
 74427 Fichtenberg
 GERMANY
 Phone +49 7971 91909-49
 Fax +49 7971 91909-51
 Jens.Peter@de.ebmpapst.com

 **Nuremberg**
 Dipl.-Wirt.-Ing. (FH) Axel Resch
 Schillerstraße 25
 74632 Neuenstein
 GERMANY
 Phone +49 7942 947-8483
 Fax +49 7942 945-8790
 Axel.Resch@de.ebmpapst.com

 **Offenburg**
 Dipl.-Ing. (FH) Ralf Braun
 Hubeneck 21
 77704 Oberkirch
 GERMANY
 Phone +49 7802 9822-52
 Fax +49 7802 9822-53
 Ralf.Braun@de.ebmpapst.com

 **Stuttgart**
 Dipl.-Ing. (FH) Rudi Weinmann
 Hindenburgstraße 100/1
 73207 Plochingen
 GERMANY
 Phone +49 7153 9289-80
 Fax +49 7153 9289-81
 Rudi.Weinmann@de.ebmpapst.com

 **Ulm**
 M.Sc. Reinhard Sommerreißer
 Einsteinstraße 7a
 86674 Baar / Schwaben
 GERMANY
 Phone +49 8276 5899-775
 Fax +49 7938 81-110
 Reinhard.Sommerreisser@de.ebmpapst.com

Distributors

 **Frankfurt**
 R.E.D. Handelsgesellschaft mbH
 Gutenbergstraße 3
 63110 Rodgau - Jügesheim
 GERMANY
 Phone +49 6106 841-0
 Fax +49 6106 841-111
 info@red-elektromechnik.de
 www.red-elektromechnik.de

 **Hamburg**
 Breuell + Hilgenfeldt GmbH
 Oststraße 96
 22844 Norderstedt
 GERMANY
 Phone +49 40 538092-20
 Fax +49 40 538092-84
 info@breuell-hilgenfeldt.de

 **Munich**
 A. Schweiger GmbH
 Ohmstraße 1
 82054 Sauerlach
 GERMANY
 Phone +49 8104 897-0
 Fax +49 8104 897-90
 info@schweiger-gmbh.de
 www.schweiger-gmbh.com

● Express Service-Center (1 to 5 pieces)

 **North**
 Breuell + Hilgenfeldt GmbH
 Oststraße 96
 22844 Norderstedt
 GERMANY
 Phone +49 40 538092-20
 Fax +49 40 538092-84
 info@breuell-hilgenfeldt.de

 **South**
 HDS Ventilatoren Vertriebs GmbH
 Glaswiesenstraße 1
 74677 Dörzbach
 GERMANY
 Phone +49 7937 80355-20
 Fax +49 7937 80355-25
 info@hds-gmbh.net
 www.hds-gmbh.net

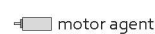

ebm-papst in Europe

Europe

 **Austria**
 ebm-papst Motoren & Ventilatoren GmbH
 Straubingstraße 17
 4030 Linz
 AUSTRIA
 Phone +43 732 321150-0
 Fax +43 732 321150-20
 info@at.ebmpapst.com
 www.ebmpapst.at

 **Belarus**
 ebm-papst Bel AgmbH
 4th Montazhnikov side street
 House 6, Office 332
 BY-220019 Minsk
 BELARUS
 Phone +375 17 2015216
 Fax +375 17 2015216
 info@by.ebmpapst.com
 www.ebmpapst.by

 **Belgium**
 ebm-papst Benelux B.V.
 Sales office Belgium-Luxemburg
 Romeinsestraat 6/0101
 Research Park Haasrode
 3001 Heverlee-Leuven
 BELGIUM
 Phone +32 16 396-200
 Fax +32 16 396-220
 info@be.ebmpapst.com
 www.ebmpapst.be

 **Bulgaria**
 ebm-papst Romania S.R.L.
 Str. Tarnavei No. 20
 500327 Brasov
 ROMANIA
 Phone +40 268 331859
 Fax +40 268 312805
 dudasludovic@xnet.ro

 **Croatia**
 ebm-papst Industries Kft.
 Ezred u. 2.
 1044 Budapest
 HUNGARY
 Phone +36 1 8722-190
 Fax +36 1 8722-194
 office@hu.ebmpapst.com

 **Cyprus**
 Helcoma
 E. Rota and Co. OE
 Davaki 65
 17672 Kallithea-Attiki
 GREECE
 Phone +30 210 9513-705
 Fax +30 210 9513-490
 contact@helcoma.gr
 www.helcoma.gr

 **Czech Republic / Slovakia**
 ebm-papst CZ s.r.o.
 Kaštanová 34a
 620 00 Brno
 CZECH REPUBLIC
 Phone +420 544 502-411
 Fax +420 547 232-622
 info@ebmpapst.cz
 www.ebmpapst.cz

 **Denmark**
 ebm-papst Denmark ApS
 Vallensbækvej 21
 2605 Brøndby
 DENMARK
 Phone +45 43 631111
 Fax +45 43 630505
 mail@dk.ebmpapst.com
 www.ebmpapst.dk

 **Estonia**
 ebm-papst Oy, Eesti Filiaal
 Kesk tee 21
 Aaviku küla, Jüri Tehnпарк
 75301 Rae Vald, Harjumaa
 ESTONIA
 Phone +372 65569-78
 www.ebmpapst.ee

 **Finland**
 ebm-papst Oy
 Puistotie 1
 02760 Espoo
 FINLAND
 Phone +358 9 887022-0
 Fax +358 9 887022-13
 mailbox@ebmpapst.fi
 www.ebmpapst.fi

 **France**
 ebm-papst sarl
 Parc d'Activités Nord
 1 rue Mohler – BP 62
 67212 Obernai Cedex
 FRANCE
 Phone +33 3 88 66 88 03
 info@ebmpapst.fr
 www.ebmpapst.fr

 **Greece**
 HELCOMA
 HELLAS IKE
 65, Davaki street
 17672 Kallithea-Attiki
 GREECE
 Phone +30 210 9513-705
 Fax +30 210 9513-490
 contact@helcoma.gr
 www.helcoma.gr

 **Hungary**
 ebm-papst Industries Kft.
 Ezred u. 2.
 1044 Budapest
 HUNGARY
 Phone +36 1 8722-190
 Fax +36 1 8722-194
 office@hu.ebmpapst.com

 **Iceland**
 RJ Engineers
 Stangarhyl 1a
 110 Reykjavik
 ICELAND
 Phone +354 567 8030
 Fax +354 567 8015
 rj@rj.is
 www.rj.is

 **Ireland**
 ebm-papst UK Ltd.
 Chelmsford Business Park
 Chelmsford Essex CM2 5EZ
 UNITED KINGDOM
 Phone +44 1245 468555
 Fax +44 1245 466336
 sales@uk.ebmpapst.com
 www.ebmpapst.co.uk

 **AuBren Limited**
 Portlaoise Business & Technology Park
 Mountrath Road
 Portlaoise, Co. Laois
 IRELAND
 Phone +353 57 8664343
 Fax +353 57 8664346
 sales@ie.aubren.com
 www.aubren.com

 **Italy**
 ebm-papst Srl
 Via Cornaggia 108
 22076 Mozzate (Co)
 ITALY
 Phone +39 0331 836201
 Fax +39 0331 821510
 info@it.ebmpapst.com
 www.ebmpapst.it

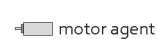
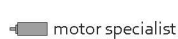

ebm-papst in Europe

 **Macedonia**
 ebm-papst Industries Kft.
 Ezred u. 2.
 1044 Budapest
 HUNGARY
 Phone +36 1 8722-190
 Fax +36 1 8722-194
 office@hu.ebmpapst.com

 **Netherlands**
 ebm-papst Benelux B.V.
 Polbeemd 7 - 5741 TP Beek en Donk
 P.O. Box 140 - 5740 AC Beek en Donk
 NETHERLANDS
 Phone +31 492 502-900
 Fax +31 492 502-950
 verkoop@nl.ebmpapst.com
 www.ebmpapst.nl

ebm-papst Heating Systems B.V.
 Van Veldekecade 360
 5216 KT 's-Hertogenbosch
 NETHERLANDS
 Phone +31 73 648 89 00
 Fax +31 73 648 89 11
 info@ebmpapst-hs.nl
 www.ebmpapst-hs.nl

 **Norway**
 ebm-papst AS
 P.B. 173 Holmlia
 1203 Oslo
 NORWAY
 Phone +47 22 763340
 Fax +47 22 619173
 mailbox@ebmpapst.no
 www.ebmpapst.no

 **Poland**
 ebm-papst Polska Sp. z o.o.
 ul. Annopol 4A
 03236 Warszawa
 POLAND
 Phone +48 22 6757819
 Fax +48 22 6769587
 office@ebmpapst.pl
 www.ebmpapst.pl

 **Portugal**
 ebm-papst (Portugal), Lda.
 Centro Empresarial de Alverca
 Rua de Adarse, Vale D'Ervas
 Corpo D / Fracção 3
 2615-178 Alverca do Ribatejo
 PORTUGAL
 Phone +351 218 394 880
 Fax +351 218 394 759
 info@pt.ebmpapst.com
 www.ebmpapst.pt

 **Romania**
 ebm-papst Romania S.R.L.
 Str. Tarnavei Nr. 20
 500327 Brasov
 ROMANIA
 Phone +40 268 331859
 Fax +40 268 312805
 dudasludovic@xnet.ro

 **Russia**
 ebm-papst Rus GmbH
 Olimpiyskiy prospect 29A, office 418
 141006 Mytistschi, Oblast Moskau
 RUSSIA
 Phone +7 495 9807524
 Fax +7 495 5140924
 info@ebmpapst.ru
 www.ebmpapst.ru

 ebm-papst Ural GmbH
 Posadskaja-Strasse, 23(E), 3
 620102 Ekaterinburg
 RUSSIA
 Phone +7 343 2338000
 Fax +7 343 2337788
 Konstantin.Molokov@ru.ebmpapst.com
 www.ebmpapst.ru

 **Serbia & Montenegro**
 ebm-papst Industries Kft.
 Ezred u. 2.
 1044 Budapest
 HUNGARY
 Phone +36 1 8722-190
 Fax +36 1 8722-194
 office@hu.ebmpapst.com

 **Spain**
 ebm-papst Ibérica S.L.
 Avda. del Sistema Solar, 29
 28830 San Fernando de Henares (Madrid)
 SPAIN
 Phone +34 91 6780894
 Fax +34 91 6781530
 ventas@ebmpapst.es
 www.ebmpapst.es

 **Sweden**
 ebm-papst AB
 Äggelundavägen 2
 17562 Järfälla
 SWEDEN
 Phone +46 10 4544400
 Fax +46 8 362306
 info@ebmpapst.se
 www.ebmpapst.se

 **Switzerland**
 ebm-papst AG
 Rütisbergstrasse 1
 8156 Oberhasli
 SWITZERLAND
 Phone +41 44 73220-70
 Fax +41 44 73220-77
 verkauf@ebmpapst.ch
 www.ebmpapst.ch

 **Turkey**
 Akantel Electronics San. Tic. LTD. Sti.
 Atatürk Organize Sanayi
 Bölgesi 10007 SK. No.:6
 35620 Cigli-Izmir
 TURKEY
 Phone +90 232 3282090
 Fax +90 232 3280270
 akantel@akantel.com.tr
 www.ebmpapst.com.tr

 **Ukraine**
 ebm-papst Ukraine LLC
 Lepse Boulevard, 4, Building 21
 03067 Kiev
 UKRAINE
 Phone +38 044 2063091
 Fax +38 044 2063091
 mail@ebmpapst.ua
 www.ebmpapst.ua

 **United Kingdom**
 ebm-papst UK Ltd.
 Chelmsford Business Park
 Chelmsford Essex CM2 5EZ
 UNITED KINGDOM
 Phone +44 1245 468555
 Fax +44 1245 466336
 sales@uk.ebmpapst.com
 www.ebmpapst.co.uk

 ebm-papst Automotive & Drives (UK) Ltd.
 The Smithy
 Fidlers Lane
 East Ilsley, Berkshire RG20 7LG
 UNITED KINGDOM
 Phone +44 1635 2811-11
 Fax +44 1635 2811-61
 A&Dsales@uk.ebmpapst.com
 www.ebmpapst-ad.com

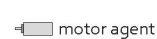
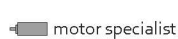

ebm-papst in America & Africa

America



Argentina

ebm-papst Argentina S.A.
Parque Industrial Canning Etapa II - Nave
61A, Perito Moreno 845, Canning (1804),
Buenos Aires
ARGENTINA
Phone +54 11 46576135
Fax +54 11 46572092
ventas@ar.ebmpapst.com
www.ebmpapst.com.ar



Brazil

ebm-papst Motores Ventiladores Ltda.
Av. José Giorgi, 301 Galpões B6+B7
Condominio Logical Center
06707-100 Cotia - São Paulo
BRAZIL
Phone +55 11 4613-8700
Fax +55 11 4777-1456
vendas@br.ebmpapst.com
www.ebmpapst.com.br



Canada

ebm-papst Canada Inc.
419 King Street West, Suite 603A
Oshawa, ON, L1J2K5
CANADA
Phone +1 905 420-3533
Fax +1 905 420-3772
sales@ca.ebmpapst.com
www.ebmpapst.ca



Mexico

ebm Industrial S. de R.L. de C.V.
Paseo de Tamarindos 400-A-5to Piso
Col. Bosques de las Lomas
Mexico 05120, D.F.
MEXICO
Phone +52 55 3300-5144
Fax +52 55 3300-5243
sales@mx.ebmpapst.com
www.ebmpapst.com.mx

USA



ebm-papst Inc.
P.O. Box 4009
100 Hyde Road
Farmington, CT 06034
UNITED STATES
Phone +1 860 674-1515
Fax +1 860 674-8536
sales@us.ebmpapst.com
www.ebmpapst.us



ebm-papst Inc.
Automotive & Drives Business Unit
3200 Greenfield Road, Suite 130
Dearborn, MI 48120
UNITED STATES
Phone +1 313 406-8080
Fax +1 313 406-8081
automotive@us.ebmpapst.com
www.ebmpapst-automotive.us

Africa



South Africa

ebm-papst South Africa (Pty) Ltd.
P.O. Box 3124
1119 Yacht Avenue
2040 Honeydew
SOUTH AFRICA
Phone +27 11 794-3434
Fax +27 11 794-5020
info@za.ebmpapst.com
www.ebmpapst.co.za



fan agent



compact fan agent



motor specialist



motor agent

ebm-papst in Asia

Asia



China

ebm-papst Ventilator (Shanghai) Co., Ltd.
No. 418, Huajing Road
WaiGaoQiao Free Trade Zone
No. 2001, Yang Gao (N) Road
200131 Shanghai
P.R. of CHINA
Phone +86 21 5046-0183
Fax +86 21 5046-1119
sales@cn.ebmpapst.com
www.ebmpapst.com.cn



Hong Kong

ebm-papst Hong Kong Ltd.
Room 17E, MG Tower
133 Hoi Bun Road, Kwun Tong
Hong Kong
P.R. of CHINA
Phone +852 2145-8678
Fax +852 2145-7678
info@hk.ebmpapst.com



India

ebm-papst India Pvt. Ltd.
26/3, G.N.T. Road, Erukkencherry
Chennai-600118
INDIA
Phone +91 44 25372556
Fax +91 44 25371149
sales@in.ebmpapst.com
www.ebmpapst.in



Indonesia

ebm-papst SEA Pte. Ltd.
Representative Office - Indonesia
Graha Telkomsigma, 4th Floor, Suite 4470
Jl. Kapt. Subijanto Dj. Bumi Serpong Damai
15321 Tangerang
INDONESIA
Phone +62 21 5376250-52
Fax +62 21 5388305
sales@id.ebmpapst.com



Israel

Polak Bros. Import Agencies Ltd.
9 Hamefalsim Street
Kiryat Arie, Petach-Tikva 49514
ISRAEL
Phone +972 3 9100300
Fax +972 3 5796679
polak@polak.co.il
www.polak.co.il



Japan

ebm-papst Japan K.K.
Attend on Tower 13F
Shinyokohama 2-8-12, Kohoku-ku
222-0033 Yokohama-City, Kanagawa
JAPAN
Phone +81 45 47057-51
Fax +81 45 47057-52
info@jp.ebmpapst.com
www.ebmpapst.jp



Korea

ebm-papst Korea Co. Ltd.
A-13F, Doosan The Land Tower
152, Magokseo-ro
Gangseo-gu
Seoul 07788
KOREA
Phone +82 2 366213-24
Fax +82 2 366213-26
info@kr.ebmpapst.com
www.ebmpapst.co.kr



Malaysia

ebm-papst SEA Pte. Ltd.
Representative Office - Malaysia
No. 16-1, Jalan Putra Mahkota 7/5A
Putra Heights
Selangor Darul Ehsan
47650 Subang Jaya
MALAYSIA
Phone +60 3 5192-7688
Fax +60 3 5614-3078
sales@my.ebmpapst.com



Philippines

ebm-papst SEA Pte. Ltd.
Representative Office - Philippines
Coherco Financial Tower
Trade Street Corner Investment Drive
Unit 1101 Madrigal Business Park
Ayala Alabang / Muntinlupa City
Phone +63 02 8042747
Fax +63 02 8042757
sales@ph.ebmpapst.com



Singapore

ebm-papst SEA Pte. Ltd.
10 Changi South Street 2
#01-01/02
Singapore 486596
SINGAPORE
Phone +65 65513789
Fax +65 68428439
sales@sg.ebmpapst.com



Taiwan

ETECO Engineering & Trading Corp.
10F-I, No. 92, Teh-Wei Str.
Tsow-Inn District, Kaohsiung
TAIWAN
Phone +886 7 557-4268
Fax +886 7 557-2788
eteco@ms22.hinet.net
www.ebmpapst.com.tw



Thailand

ebm-papst Thailand Co., Ltd.
99/9 Moo 2, Central Chaengwattana Tower
8th Floor, Room 801-802
Chaengwattana Road Bangtarad, Pakkret
11120 Nonthaburi
THAILAND
Phone +66 2 8353785-7
Fax +66 2 8353788
sales@th.ebmpapst.com



United Arab Emirates

ebm-papst Middle East FZE
PO Box 17755
Jebel Ali Free Zone / FZS1 / AP05
Dubai
UNITED ARAB EMIRATES
Phone +971 4 88608-26
Fax +971 4 88608-27
info@ae.ebmpapst.com
www.ebmpapst.ae



Vietnam

ebm-papst SEA Pte. Ltd.
Representative Office - Vietnam
Floor M, Phuong Long Building,
506 Nguyen Dinh Chieu Street,
Ward 4, District 3,
Ho Chi Minh City
VIETNAM
Phone +84 28 3929 0699
Fax +84 28 3929 0669
sales@vn.ebmpapst.com



fan agent



compact fan agent



motor specialist



motor agent

ebm-papst in Oceania

Oceania

 **Australia**
ebm-papst A&NZ Pty Ltd.
10 Oxford Road
Laverton North, Victoria, 3026
AUSTRALIA
Phone +61 3 9360-6400
Fax +61 3 9360-6464
sales@ebmpapst.com.au
www.ebmpapst.com.au

 **New Zealand**
ebm-papst A&NZ Pty Ltd.
61 Hugo Johnston Drive, Unit H
Penrose 1061, Auckland
NEW ZEALAND
PO Box 112278,
Penrose 1642, Auckland
Phone +64 9 525-0245
Fax +64 9 525-0246
sales@ebmpapst.com.au
www.ebmpapst.com.au

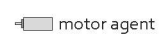

ebmpapst

the engineer's choice



ebm-papst
Mulfingen GmbH & Co. KG

Bachmühle 2
74673 Mulfingen
Germany
Phone +49 7938 81-0
Fax +49 7938 81-110
info1@de.ebmpapst.com