



Introduction:

The hand tool is designed to crimp a variety of loose piece insulated terminals/connectors. It combines the general purpose service tools with the reliability and ease of use of crimping premium insulated terminals/connectors.

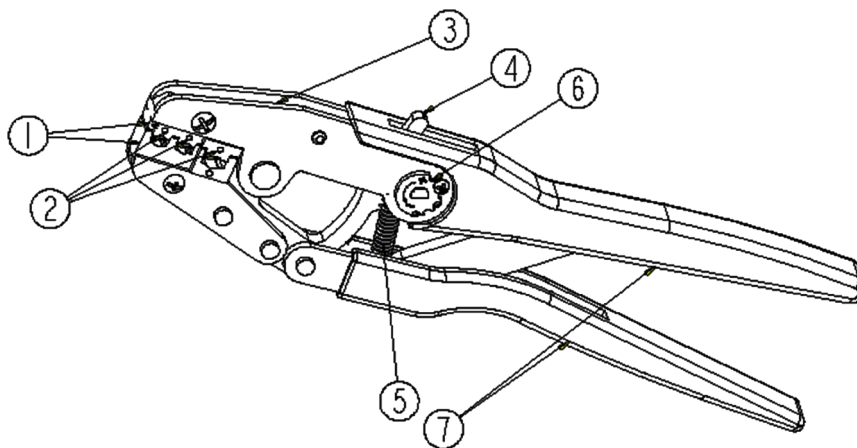

Figure 1

1. Die set
2. Die color code
3. Body
4. Pawl release lever
5. Spring
6. Ratchet adjuster
7. Plastic grip

Net weight: 570g

Description

The front of the crimping dies is marked with die color code shown wire size ranges.

The tool features a fixed die (crimper) for Nylon, Vinyl, PC insulated terminals/connectors on #22-10AWG stranded copper wire.

Hand tool ratchet assures full crimping of the contact. Once engaged, the ratchet will not release until the dies have been fully closed.

Newark.com/multicomp-pro
Farnell.com/multicomp-pro
Element14.com/multicomp-pro

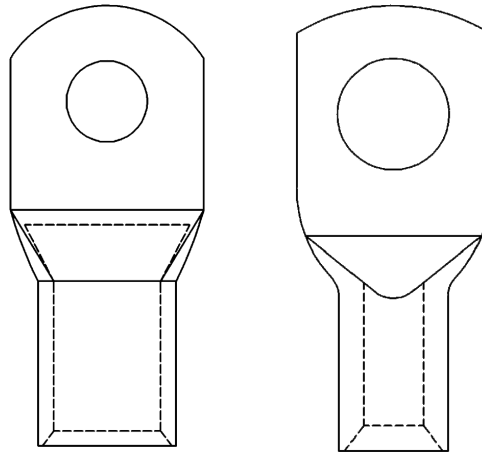

Non-Insulated Copper Tubular Lugs

Table 1: Reference Guide for crimping tool

Crimping Procedure

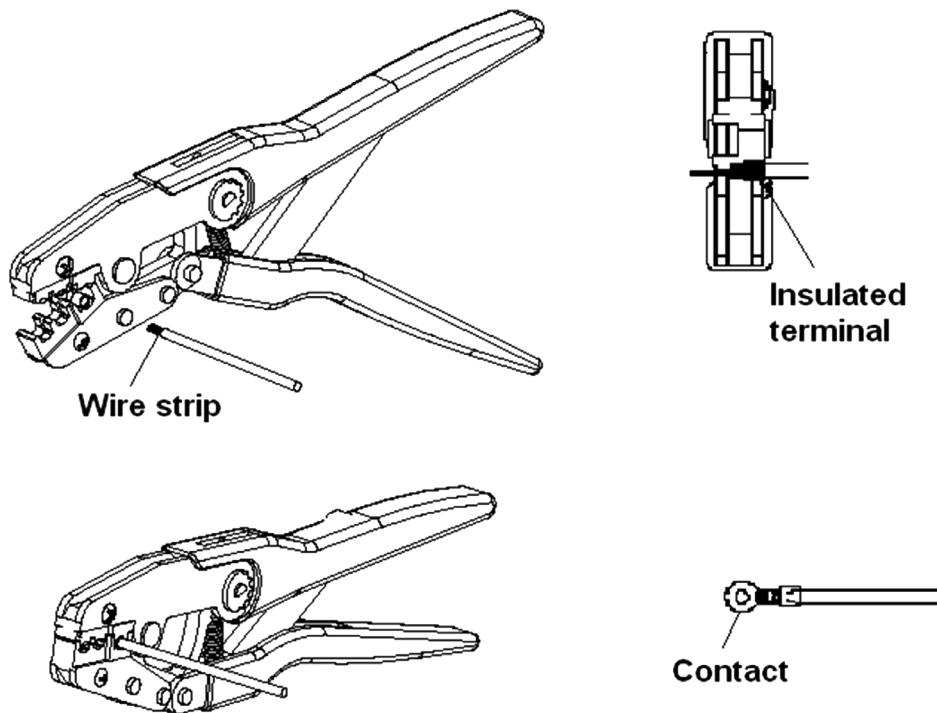

Figure 2

Crimp Tool

Refer to the table 1 in the drawing and ensure that the wire intended for use is compatible with the wire size and insulation diameter specified in the table. Strip the wire to the length indicated in the table.

CAUTION: DO NOT cut the wire strands during wire stripping.

Proceed as follows:

1. Hold the tool so that the front side of die color code is facing you.
2. Ensure that the tool ratchet is released by squeezing the tool handles and allowing them to open FULLY.
3. Holding the contact and looking straight into the crimp section, insert the contact from the back of the tool into the appropriate crimp chamber.
4. Position the contact between the die set so that the terminal/connector in the proper die. The center of insulated terminal/connector should be proper in cavity. Refer Figures 2.
5. Holding the contact in this position, depress the tool handles together until the upper die starts entry into the insulation terminals. Do not deform the insulation insulated part or wire.
6. Insert a properly stripped wire through the insulated terminal/connector of the contact until the proper wire location
7. Holding wire in place, crimp insulated part to the wire by squeezing the tool handles together until the ratchet release.
8. Allow tool handles to open fully and remove the crimped contact from the tool.

Caution:

Use correct terminal/connector, if any object oversize terminal/connector jams in the tool that may cause damage.

- Tool is designed for hand grip force only, use of other force may damage tool.
- Do not force on handles to open tool, damage may result.

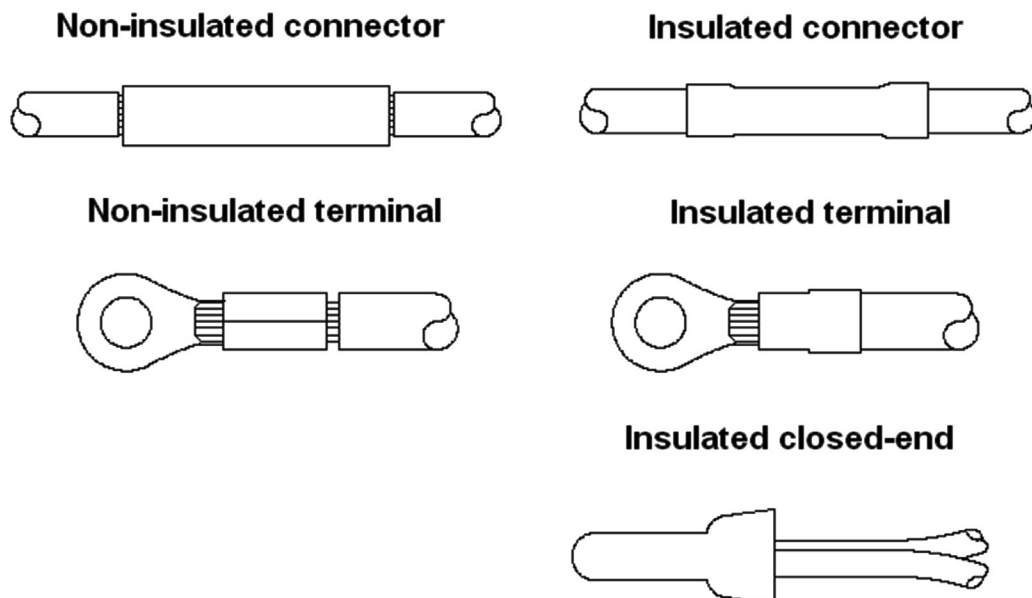

Figure 3

After crimped terminal/connector, use visual to inspect the proper die indent location and wire location. See Figure 3.

Maintenance And Inspection Procedure

It is recommended that a maintenance and inspection program be performed periodically to ensure dependable and uniform terminations. Frequency of inspection depends on:

- The care, amount of use, and handling of the hand tool
- The presence of abnormal amounts of dust and dirt
- The degree of operator skill
- Your own established standards
- The environment where used

The hand tool is inspected before being shipped; however, it is recommended that the tool be inspected immediately upon its arrival at your facility to ensure that the tool has not been damaged during shipment.

Cleaning

Remove dust, moisture, and other contaminants with a clean brush, or a soft cloth. Do not use objects that could damage the tool. Please lubricate on surfaces after cleaning.

Lubrication

Lubricate all pins, pivot points and bearing surfaces with medium weight oil.

Visual Inspection

Inspect tool for any missing parts, springs, and crimping dies for broken or chipped surfaces.

Warning

Contact with electricity can cause serious injury or death. Shut off power at the circuit breaker or remove fuse before using the product. The manufacturer and distributor warrant this product only for material and workmanship, and they shall not be liable for any special, incidental or consequential damages or for any damage or loss caused by improper use or installation.

Part Number Table

Description	Part Number
Crimp Tool	KST2000D-1516

Important Notice : This data sheet and its contents (the "Information") belong to the members of the AVNET group of companies (the "Group") or are licensed to it. No licence is granted for the use of it other than for information purposes in connection with the products to which it relates. No licence of any intellectual property rights is granted. The Information is subject to change without notice and replaces all data sheets previously supplied. The Information supplied is believed to be accurate but the Group assumes no responsibility for its accuracy or completeness, any error in or omission from it or for any use made of it. Users of this data sheet should check for themselves the Information and the suitability of the products for their purpose and not make any assumptions based on information included or omitted. Liability for loss or damage resulting from any reliance on the Information or use of it (including liability resulting from negligence or where the Group was aware of the possibility of such loss or damage arising) is excluded. This will not operate to limit or restrict the Group's liability for death or personal injury resulting from its negligence. Multicomp Pro is the registered trademark of Premier Farnell Limited 2019.