

Pressure Sensor 0 to 50 and 0 to 150 PSIG



Datasheet

Model	Description	Connection
BWA-PRESSURE-SENSOR-50	Includes pressure sensor PS1G50; 0-50 psi range; gauge; 1/4"-18 NPT port	1 meter cable
BWA-PRESSURE-SENSOR-150	Includes pressure sensor PS1G150; 0-150 psi range; gauge; 1/4"-18 NPT port	

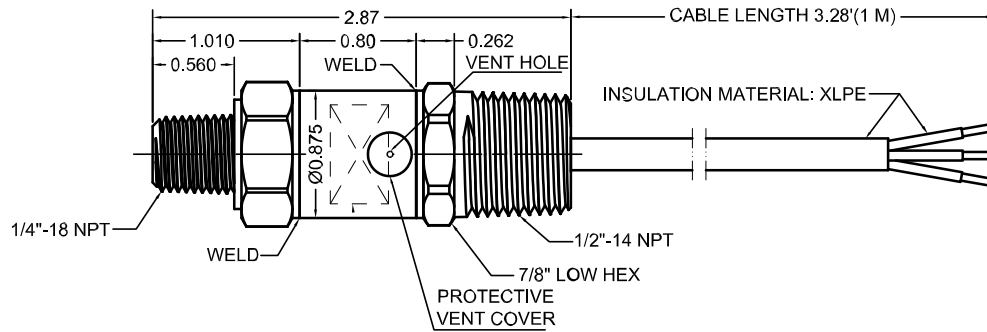
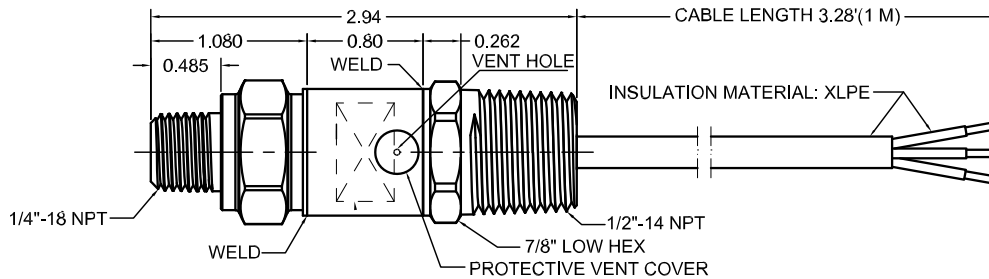

Figure 1. Model BWA-PRESSURE-SENSOR-50



NOTE: PROTECTIVE VENT COVER AND VENT HOLE ONLY FOR GAGE SENSOR.

Figure 2. Model BWA-PRESSURE-SENSOR-150

Wire Color	Description
brown (bn)	Supply +
blue (bu)	Supply -
green (gn)	Output

Specifications

Supply Voltage

9 V dc to 30 V dc

Current Consumption

< 3 mA

Pressure Range

Proof: 2X FS
Burst: 3X FS

Output

0 V dc to 5 V dc

Fatigue Life

More than 4 million cycles

Accuracy

± 1.0% BFSL

Stability

± 0.25% per Year

Pressure Port

1/4"-18 NPT

Construction

0-50 Model: 304 SS Housing; 316 SS wetting material; Media is compatible with 316 SS
0-150 Model: 304 SS housing; 17-4PH SS wetting material; Media is compatible with 17-4PH SS

Electrical Connection

Conduit Fitting with Cable

Temperature

Compensated: 0 °C to 85 °C (32 °F to 185 °F)
Operating: -40 °C to 125 °C (-40 °C to 257 °F)

Environmental Rating

IEC IP65

Zero/Span Offset Tolerance

± 2.5% FS

