

# TLF80511 Demo Board

Product Manual

## Application Note

Rev. 1.0, 2012-07-04

Automotive Power

## 1 Introduction

The TLF80511 Demoboard is a demonstration of the Infineon low dropout linear voltage regulator. The TLF80511 is the ideal IC to supply regulated voltage for general ECU's and infotainment applications. The fixed output voltage makes the TLF80511 suitable for supplying the majority of standard applications.

This application note contains information for the TLF80511 Demoboard.

### 1.1 General Description

The TLF80511 is a linear low dropout voltage regulator for load currents up to 400 mA. An input voltage up to 40 V (functional range) is regulated to  $V_{OUT,nom} = 5\text{ V}$  with  $\pm 2\%$  precision.

The TLF80511, with a typical quiescent current of  $38\mu\text{A}$ , is the ideal solution for systems requiring very low operating current, such as those permanently connected to a battery.

It features a very low dropout voltage of 100 mV, when the output current is less than 100 mA. In addition, the dropout region begins at input voltages of 3.3 V (extended operating range). This makes the TLF80511 suitable to supply automotive systems.

In addition, the TLF80511's new fast regulation concept requires only a single,  $1\mu\text{F}$  output capacitor to maintain stable regulation.

For more detailed information please see also TLF80511 data sheet [1].

### 1.2 TLF80511 Feature List

- Output Voltage 5 V
- Output Voltage Precision  $\pm 2\%$
- Output Current up to 400 mA
- Ultra Low Current Consumption  $38\mu\text{A}$
- Very Low Dropout Voltage: 100 mV at 100 mA Output Current
- Extended Operating Range Starting at 3.3 V
- Small Output Capacitor  $1\mu\text{F}$
- Output Current Limit
- Overtemperature Shutdown
- Suitable for Use in Automotive Electronics
- Wide Temperature Range from  $-40\text{ }^\circ\text{C}$  up to  $150\text{ }^\circ\text{C}$
- Green Product (RoHS compliant)
- AEC Qualified

### 1.3 Block Diagram

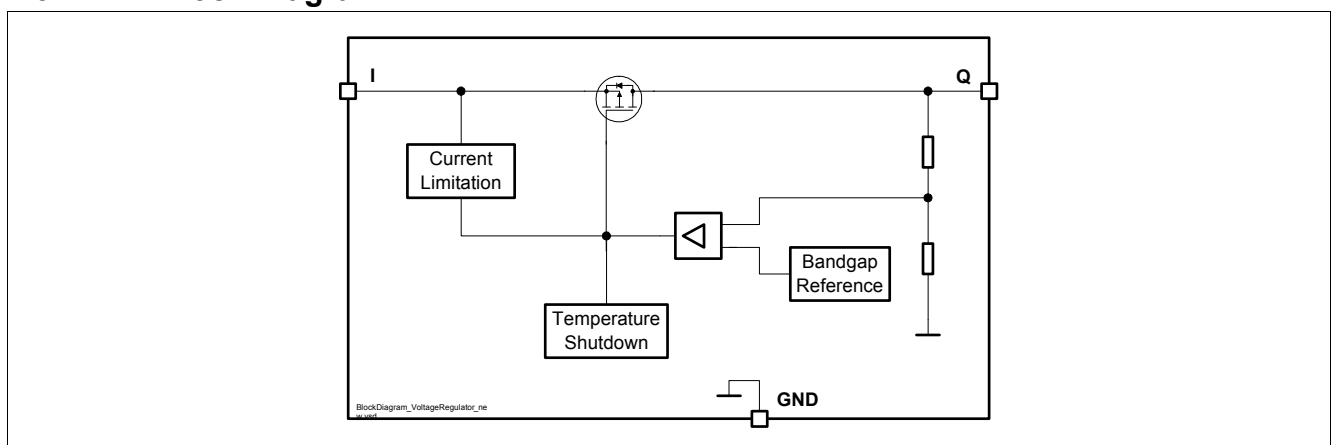

Figure 1 Block and simplified application diagram of TLF80511

## 2 Demoboard

The TLF80511 Demoboard is equipped with TLF80511TC and the necessary external components.

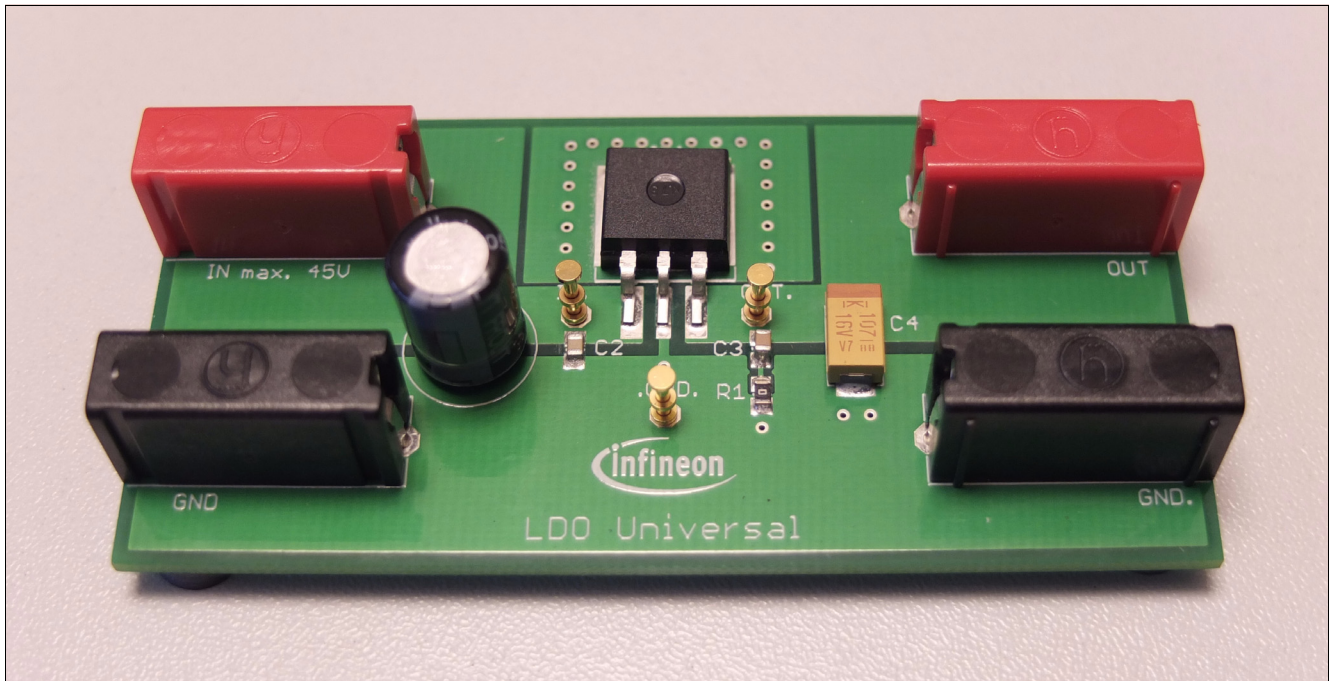

Figure 2 TLF80511 Demoboard

### 2.1 Operating Conditions

To avoid damage of the Demoboard, the maximum of the operating range defined in [Table 1](#) must be followed.

Table 1 Input / output operating range <sup>1)</sup>

Parameter	Symbol	Limit Values		Unit
		Min.	Max.	
Board Supply	IN	3.3 <sup>2)</sup>	45 <sup>3)</sup>	V
Regulator Output	OUT	$V_{IN} - V_{drop}$	5	V
Output Current	$I_{OUT}$	0 <sup>4)</sup>	400 <sup>3)</sup>	mA

1) The demo board is operating at ambient temperature of 25°C.

2) The min. value depends on the min. Extended Input Voltage Range of the TLF80511

3) The max. value depends on the max. rating of external components on the board and the TLF80511.

4) The performance in low load condition (< 0.05 mA) is described in the TLF80511 data sheet [\[1\]](#).

## 2.2 Quick Start Procedure

1. With power off, connect the input power supply to IN and GND.
2. Connect the load between OUT and GND.
3. Turn on the input power supply. Make sure that the input voltage does not exceed 45 V.

## 2.3 Board Configuration

The TLF80511 Demoboard is easy to use and provides a fixed output voltage of 5.0 V

## 2.4 Schematic

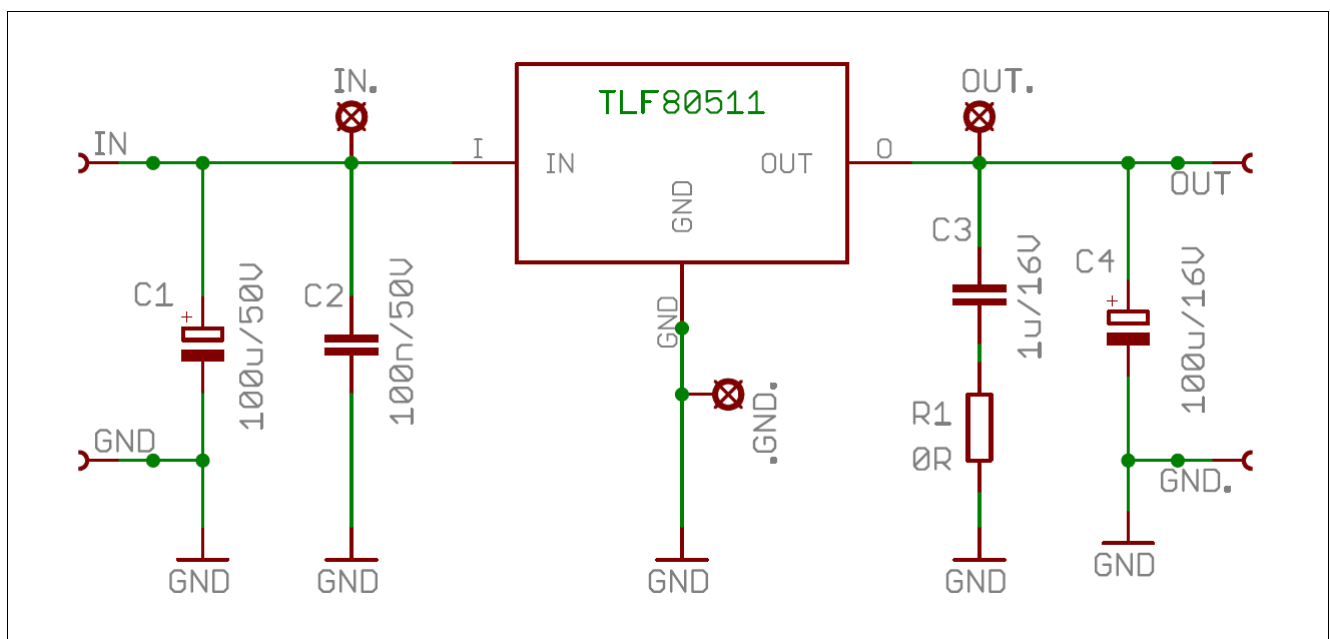

Figure 3 TLF80511 Demoboard schematic

## 2.5 Bill of Material

Table 2 Bill of material

Part	Value	Package
IN	Banana jack	BABU4MM
GND	Banana jack	BABU4MM
OUT	Banana jack	BABU4MM
.GND.	Banana jack	BABU4MM
C1	100µ/50V	CPOL-EUE
C2	100n/50V	C0805
C3	1µ/16V	C0805
C4	100µ/16V	CPOL-EUSMCD
R1	0R	R0805

## 2.6 Board Layout

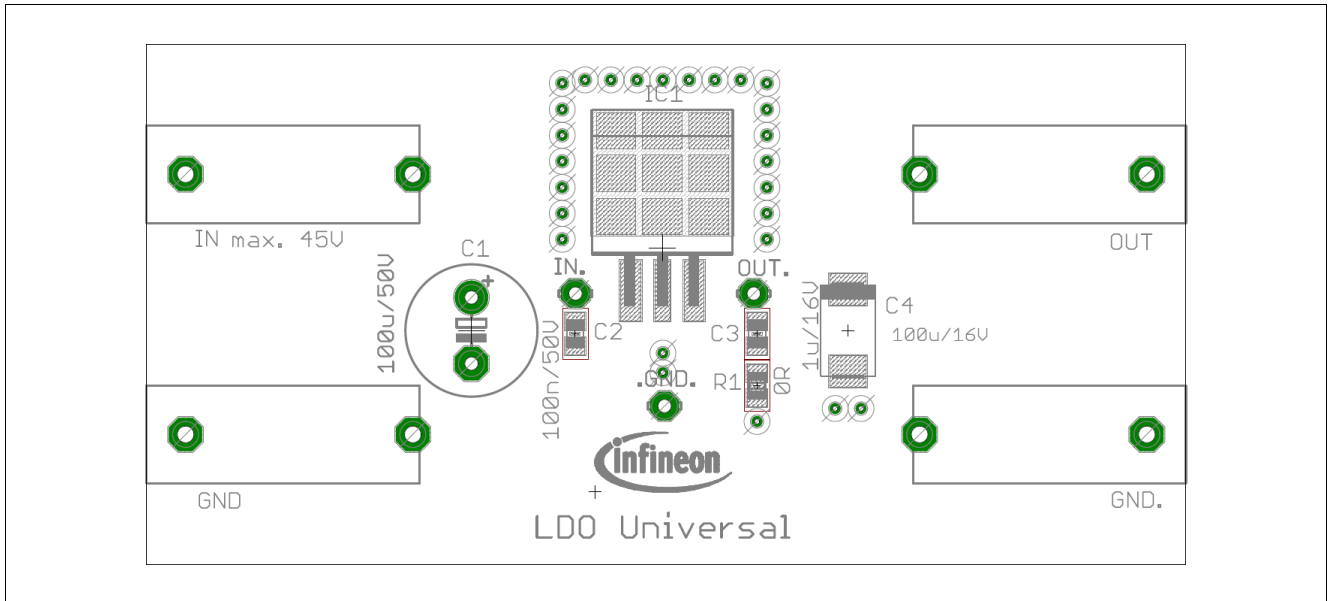

Figure 4 TLF80511 Demoboard top layer component placement

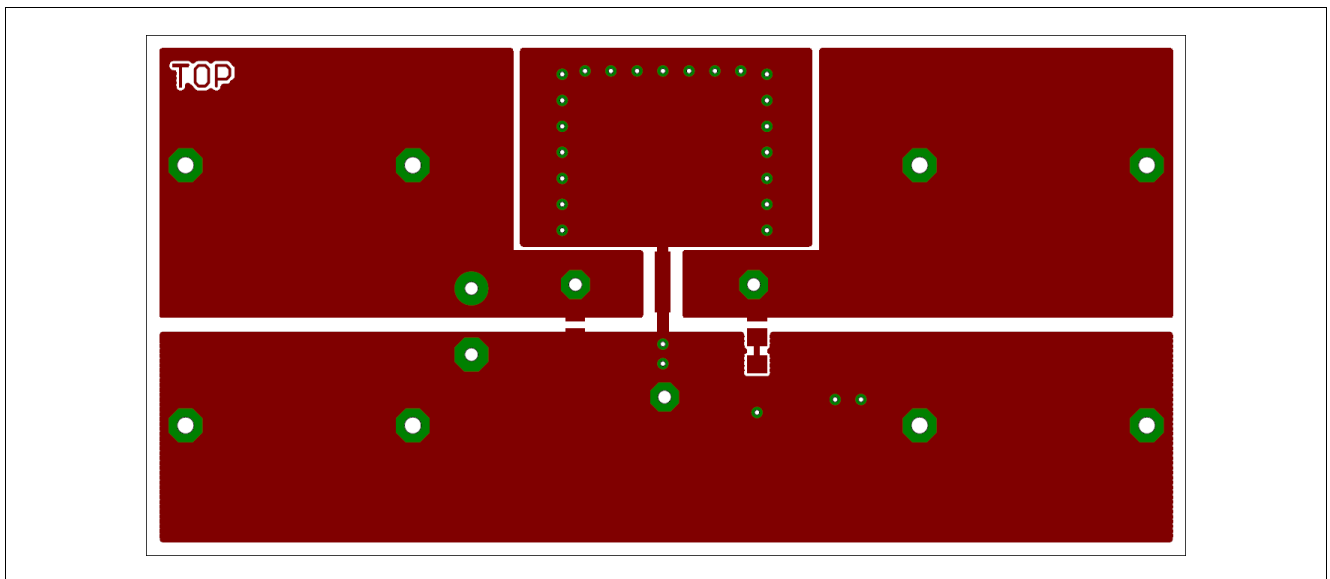

Figure 5 TLF80511 Demoboard top layer

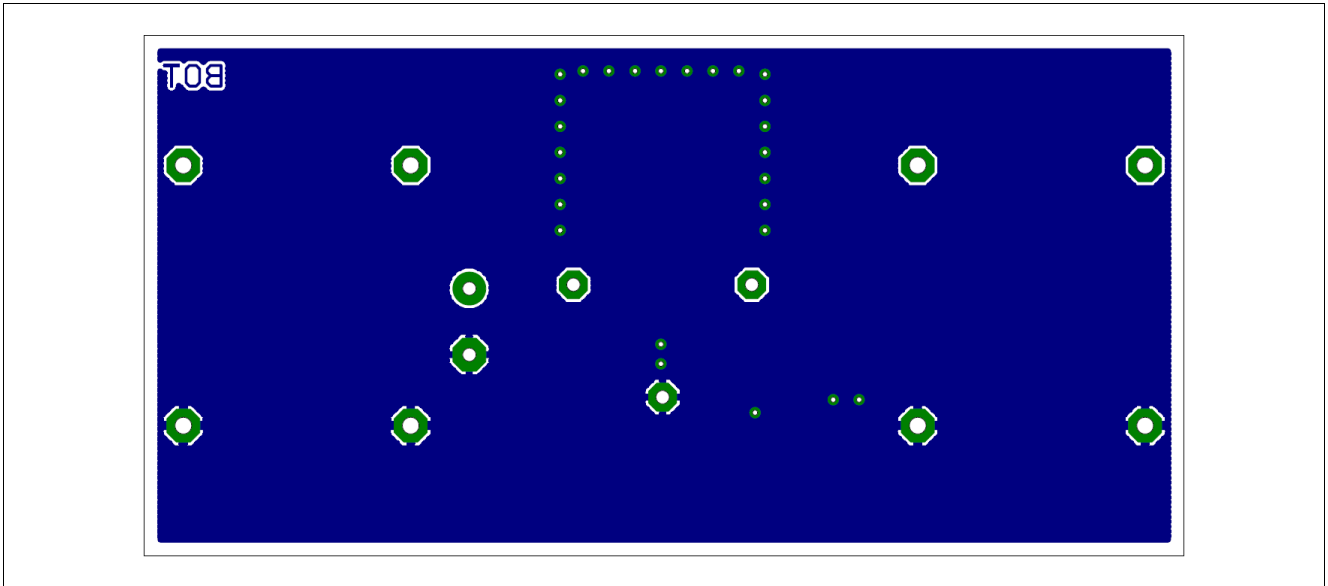

Figure 6 TLF80511 Demoboard bottom layer

### **3 Restrictions**

This Demoboard is offering limited features allowing you only to evaluate and test the Infineon products. The Demoboard is not an end product (or finished appliance), nor is it intended or authorized by Infineon to be integrated into end products. You are not authorized to use the Demoboard in any production system.

## 4 Reference

- [1] TLF80511 Data Sheet (For further information you may contact <http://www.infineon.com/>)





**Edition 2012-07-04**

**Published by  
Infineon Technologies AG  
81726 Munich, Germany**

**© 2012 Infineon Technologies AG  
All Rights Reserved.**

#### **LEGAL DISCLAIMER**

THE INFORMATION GIVEN IN THIS APPLICATION NOTE IS GIVEN AS A HINT FOR THE IMPLEMENTATION OF THE INFINEON TECHNOLOGIES COMPONENT ONLY AND SHALL NOT BE REGARDED AS ANY DESCRIPTION OR WARRANTY OF A CERTAIN FUNCTIONALITY, CONDITION OR QUALITY OF THE INFINEON TECHNOLOGIES COMPONENT. THE RECIPIENT OF THIS APPLICATION NOTE MUST VERIFY ANY FUNCTION DESCRIBED HEREIN IN THE REAL APPLICATION. INFINEON TECHNOLOGIES HEREBY DISCLAIMS ANY AND ALL WARRANTIES AND LIABILITIES OF ANY KIND (INCLUDING WITHOUT LIMITATION WARRANTIES OF NON-INFRINGEMENT OF INTELLECTUAL PROPERTY RIGHTS OF ANY THIRD PARTY) WITH RESPECT TO ANY AND ALL INFORMATION GIVEN IN THIS APPLICATION NOTE.

#### **Information**

For further information on technology, delivery terms and conditions and prices, please contact the nearest Infineon Technologies Office ([www.infineon.com](http://www.infineon.com)).

#### **Warnings**

Due to technical requirements, components may contain dangerous substances. For information on the types in question, please contact the nearest Infineon Technologies Office.

Infineon Technologies components may be used in life-support devices or systems only with the express written approval of Infineon Technologies, if a failure of such components can reasonably be expected to cause the failure of that life-support device or system or to affect the safety or effectiveness of that device or system. Life support devices or systems are intended to be implanted in the human body or to support and/or maintain and sustain and/or protect human life. If they fail, it is reasonable to assume that the health of the user or other persons may be endangered.