

Embedded Power

*AC-DC and DC-DC
Power Conversion
Solutions*





Contents

AC–DC Power Supplies

Low Power 3-650 W	
■ Open frame/enclosed 1-4 outputs	9
■ External power adapters	20
Fanless/Conduction Cooled Up to 600 W	
■ Enclosed / IP64 250 W Series	17
■ Enclosed / IP65 600 W Series	19
Healthcare Power Up to 24000 W	
■ 1-24 outputs	22
Micro Medium Power (μMP) Up to 1800 W	
■ Up to 12 outputs	27
Intelligent Medium Power (iMP) Up to 1500 W	
■ Up to 21 outputs	29
Intelligent High Power (iVS) Up to 4920 W	
■ Up to 24 outputs	32
Precision High Power System (iHP) Up to 24000 W	
■ Up to 8 outputs	35
Bulk Power 300-12000 W	
■ Bulk front end	38
■ Distributed power bulk front end	48
Distributed and CRPS Power 450-3000 W	
■ Available 1U, 2U and 3U	51
Project Olympus Power - Compute Power	
■ PS1000 No batteries	60
■ PL1000 With batteries	60
Project Olympus Power - Storage Power	
■ PS1650	61
Power Shelf	
■ 1U 19" and 21" Power Shelf	62
DIN Rail (ADN) 120-960 W	
■ Single & 3-phase	63

DC–DC Converters

Industry Standard Isolated	
■ Sixteenth-Brick	67
■ Eighth-Brick	68
■ Quarter-Brick	70
■ RF Power Brick	71
■ Wide Input Voltage	72
■ Direct Conversion – PSA Series	72
Industry Standard Non-Isolated	
■ C-Class	73
■ E-Class	75
■ POLA Products	76
■ Digital DC-DC Converters	77
High Power 300 V Input	
■ On-board AC–DC Distributed Architecture	78
■ Power Factor Correction (PFC)	79
Low Power Industrial	
■ Low Power Isolated DC-DC Product	80
■ DC-DC Converter for Railway Application	86
■ DC-DC Converter for Medical Application	88
Rapid Modification and Value-Added Solutions	
	90
Terms and Conditions	
	92
Index	
	95

Artesyn Embedded Power is a global leader in the design and manufacture of highly reliable power conversion solutions for a wide range of industries including communications, computing, server storage, healthcare and industrial.

Artesyn is one of the world's largest and most successful power supply companies and embraces the well-known Astec brand. The company's extensive standard AC-DC product portfolio covers a power range of 3 watts to 24 kilowatts and includes open-frame and enclosed models, conduction cooled units, highly configurable modular power supplies, rack-mounting bulk front end units and power systems for horticultural LED lighting. Many of these products are available in medically approved versions and a large number of the higher power models feature extensive built-in intelligence.

Widely acknowledged as an industry leader in distributed power applications, Artesyn produces an exceptionally wide range of DC-DC power conversion products with power ratings from 2 watts to 1,300 watts. These include 48V-input, telecom-grade isolated DC-DC converters in industry-standard sixteenth-brick to full-brick form factors. Artesyn's application-optimized families of DC-DC converters cover the application areas of non-isolated, industrial, railway and medical applications. The company also provides a family of DC-DC converters to support AC input voltage applications with factorized power (PFC + DC-DC) full and half bricks. Customized solutions in Artesyn's board-mounted power portfolio include processor voltage regulator modules (VRMs).

Artesyn's engineering and technical support is backed by world-class manufacturing that can significantly reduce time-to-market and help customers gain a clear competitive edge. Artesyn has over 8,000 employees worldwide across multiple engineering design centers, manufacturing facilities, and global sales and support offices.

Let Artesyn help your business improve time-to-market and shift development efforts to the deployment of new, value-add features and services that build market share.



Local Support

Our regional sales offices are ready to provide expert local applications and sales support. In addition, an extensive network of manufacturers' representatives and distributors bring our products to you. Please call for locations of sales offices near you or visit our website at www.artesyn.com.

Americas (USA)

Telephone: +1 888 412 7832

Europe (UK)

Telephone: +44 (0) 1384 842 211

Asia (HK)

Telephone: +852 2176 3333

Technical Support

Americas (USA)

+1 888 412 7832 (North America)

Europe, Middle East and Africa (EMEA)

0 800 0321546 (UK)

+44 800 0321546 (outside UK)

Asia

+400 88 99 130 (China)

+86 29 8874 1895 (outside China)

Email:

Asia, Americas and EMEA

productsupport.ep@artesyn.com

Embedded Power Selector Guide

AC-DC

Modular

iMP Series
Up to 1500 W
1 - 21 Outputs



uMP Series
Up to 1800 W
Up to 12 Outputs



iVS Series
Up to 4920 W
1 - 24 Outputs



iHP Series
Up to 24000 W
Up to 8 Outputs



Bulk/Distributed/Enclosed

LCM Series
300, 600, 1000, 1500, 3000 W
85 - 264 Vac
12 - 72 Vdc



DS Series
450 - 3000 W
90 - 264 Vac
12, 24, 48 Vdc



CSU Series
550, 800, 1300, 1800, 2000, 2400 W
90-264 Vac
12 Vdc



CSV Series
1100, 1300, 1600, 2000 W
90-264 Vac
12 Vdc



UFE Series
1300 - 2000 W
85 - 264 Vac
24, 48 Vdc



HPS Series
1 - 3000 W
90 - 264 Vac
48 Vdc



DC-DC

PFC
Full Brick; AIF
3/4 Brick; AIT
1/4 Brick; AIQ



High Power
Full Brick; AIF
3/4 Brick; AIT
1/2 Brick; AIH
1/4 Brick; BDQ/BCQ



Telecom DC-DC
1/16th brick 35 - 120 W; ALD/AVD
1/8th brick 50 - 300 W; AVO/ADO
1/4 brick 50 - 800 W; AVQ/ADQ
1/2 brick 300 - 700 W; AVE/ADH
Full brick 500 - 800 W; AGF



Industrial DC-DC
0.5 by 0.5 DIP 2 W, 3 W; AYA
0.9 by 0.5 DIP 3 W; ATA
1.2 by 0.8 DIP 24 6 W, 10 W; ASA
1 by 1; 10 W, 20 W, 25 W; AXA
1 by 2; 15 W, 40 W, 50 W; AEE
1.6 by 2; 25 W, 30 W; AET



Racks

OCP Compatible

1U,
18 kW



Scorpio

3U,
14.4 kW



UFR

1U, 6 kW
Accepts 3 UFE units



DSR1

1U, 6 kW
Accepts 5
DS units



HPR1

1U, 12 kW
Accepts 4
HPS3000



Direct Conversion - PSA Series

100 A; ADC



Non-Isolated DC-DC

C2 Class 3 - 60 A; LDO, SMT, SIL
LGA package 3 - 20 A; LGA
LGA50D, LGA80D 25 - 80 A;
LGA50D, LGA80D
POLA package 6 - 60 A; PTH



Medical DC-DC

0.8 by 1.2; Medical 6 W; ASA
1 by 2; Medical 10 W, 15 W, 20 W; AEE



Railway DC-DC

1 by 2; Railway 10 W, 20 W; ERM
1/4 brick Railway 50 W, 75 W; ERM



Adapters

DCH Series

3 W
5 V



DA Series

5 - 45 W
5 - 20 V



AD Series

24 W
12 V



DP Series

40 - 100 W
5 - 54 V



Open Frame

NPS20-M
NPS40-M
NPT40-M
NPS60-M
LPT100-M
LPS100-M
CPS250-M

25 - 40 W
45 - 60 W
45 - 55 W
60 W
80 - 130 W
100 - 150 W
150 - 250 W

2x4



LP40/40-M
NLP65
LP60/60-M
TLP150
LPQ200-M
LPS200-M
LPS360-M

40 - 55 W
65 - 75 W
60 - 80 W
100 - 150 W
100 - 200 W
125 - 250 W
200 - 360 W

3x5



CNS650-MU
400 - 650 W



4x6

NLP250
175 - 250 W



4x7

Fanless/Conduction Cooled

LCC250
250 W



4x7

LCC600
600 W



4x9

ADN-C Series

120 - 960 W
Single & 3-phase
Approved for UL508 &
Hazardous Locations



Special

For more information and a complete overview of Embedded Power products and services go to www.artesyn.com



Accelerate, Improve and Enhance the Capabilities of Your Next System Design.

A History of Innovation

At Artesyn Embedded Power, our engineers have been designing and developing power supply products for over 40 years. Our products have helped pave the way for advancements in numerous applications in the communications, industrial, computing, data storage and healthcare markets.

When developing products, time is money. Every step in the process that you can eliminate, speed up, or make more effective accelerates your time-to-market and lowers your R&D costs. Major advantages of partnering with Artesyn include:

- Broadest power supply product lines
- Highly versatile power supplies
- Modified standards and value-add services
- Low energy consumption
- Eco-friendly products
- Space-efficient power
- Reliability & quality
- Worldwide distributor network
- Vast knowledge, experience & expertise

Power for the Next Generation

Many of our products incorporate powerful programming, monitoring and self-testing software providing system engineers with critical data to manage power consumption. High efficiency, green design and manufacturing technologies, and innovative demand and supply replenishment systems collectively deliver key business efficiencies and new design capabilities.

Artesyn can help take your new product design or redevelopment efforts to the next level with a shorter time-to-profit, higher reliability and greater scalability. Artesyn benefits include:

- **Shorter Time-to-Market** – our latest programmable power solutions and our modular, medium/high power μ MP and iMP series provide you with shorter time-to-market and offer faster test and qualification than traditional analog power solutions. Our modified standards and value-add services also provide turn-key solutions for the best application match to help accelerate time-to-market without compromising quality.
- **Higher Reliability** – moving from inflexible fixed-output analog power supplies to programmable power solutions enables our engineers to more extensively test and document our products to ensure they meet or exceed your reliability requirements. And we provide a wide range of on-line environmental, EMC compliance and safety certification to help speed your product design process.
- **Greater Scalability** – many of our latest power solutions are scalable, programmable and plug-compatible with our earlier-generation products, enabling you to quickly address changes or enhancements to your systems. You can now satisfy most changes in power requirements simply by reprogramming the power supply – and if your needs change radically, you can easily swap to a more capable solution. This inherent scalability eliminates redesign costs, reduces testing time and provides you with greater design flexibility.

Artesyn utilizes the following design methodologies and techniques to ensure that our power supplies meet the rigorous quality and reliability requirements of the communications, industrial, computing, data storage and healthcare markets.

Power Supply Design Controls

Reliability Models and Predictions

- A prediction of design reliability in terms of Mean Time Between Failures (MTBF) using Telecordia, Bellcore or MIL-HDBK-217F
- Not intended as a measure of expected field performance, but for design trade-off analysis and review of part stress derating performance

Failure Modes and Effect Analysis

- An analytical technique to identify and review failure modes, their causes, mechanisms and effects
- Provides a formal risk assessment to reduce field failures at the customer site

Component Selection

- Database warehouse of all component information
- Design engineers can only select components rigorously approved from suppliers that have undergone strict qualification and auditing process

Derating Analysis

- Intended to reduce the failure rate of components

Design for Manufacturability

- Design rules regarding manufacturability

Simulation Analysis – Computer-Aided Engineering Tools

- Thermal Simulation
- Circuit Simulation
- EMI Field Simulation
- Detailed Mechanical Design
- PCB Layout and Tracking
- Structural Simulation

Artesyn Computer-Aided Engineering Tools

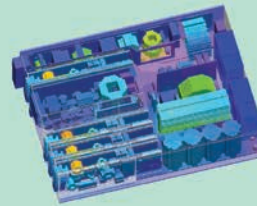

Thermal Simulation

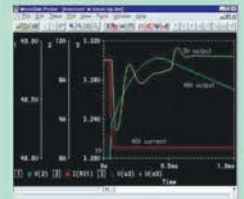

Circuit Simulation

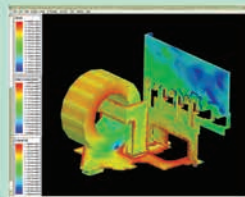

EMI Field Simulation



Detailed Mechanical Design

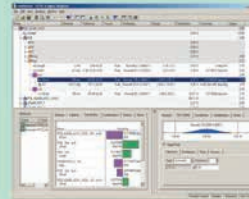

PCB Layout and Tracking

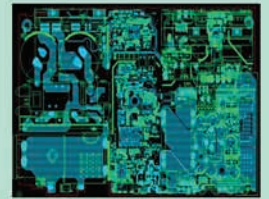

Structural Simulation

For additional information go to www.artesyn.com



AC-DC Power Supplies

Artesyn Embedded Power is widely acknowledged as an industry leader and produces an exceptionally wide range of AC-DC power conversion products.

Low Power

Open frame 1-4 outputs

20-650 Watts





Special Features

All models feature:

- Industry standard footprints
- Wide-range AC input
- Full power to 50 °C
- High demonstrated MTBF
- Overvoltage protection
- Overload protection
- Built-in EMI filtering
- Extensive safety approvals
- Derated operation to 70 °C

Many models feature:

- EN61000-3-2 compliance
- Supervisory outputs (5 V/12 V)
- Wide-adjust floating 4th output
- Single wire current share
- Medical approvals
- Remote sense
- Adjustable outputs
- Power fail
- Wide-adjust on single output models
- Derated operation to 80 °C

Output Power		Output				Size W x L x H (mm)	Model
[Forced Air]	Free Air	V1	V2	V3	V4		
[40 W]	25 W	NPS20-M Series**				2" x 4" x 1" (50.8 x 101.6 x 25.4)	NPS22-M
		5 V @ 5 A [8 A]*					NPS23-M
		12 V @ 2.1 A [3.3 A]*					NPS24-M
		15 V @ 1.7 A [2.7 A]*					NPS25-M
		24 V @ 1 A [1.8 A]*					NPS28-M
		48 V @ 0.5 A [0.84 A]*					
[55 W]	40 W	LP40 Series**				3" x 5" x 1.2" (76.2 x 127 x 30.5)	LPS41
		3.3 V @ 8 A [11 A]*					LPS42
		5 V @ 8 A [11 A]*					LPS43
		12 V @ 3.3 A [4.5 A]*					LPS44
		15 V @ 2.6 A [3.6 A]*					LPS45
		24 V @ 1.6 A [2.3 A]*					LPS48
		48 V @ 0.9 A [1.2 A]*					
		3.3 V @ 4 A [7 A]	5 V @ 1.5 A [2 A]	+12 V @ 0.5 A [0.7 A]			LPT41
		5 V @ 4 A [5 A]	12 V @ 2 A [2.5 A]	-12 V @ 0.5 A [0.7 A]			LPT42
		5 V @ 6 A [8 A]	12 V @ 0.5 A [0.7 A]	-12 V @ 0.5 A [0.7 A]			LPT43
		5 V @ 4 A [5 A]	12 V @ 2 A [2.5 A]	-5 V @ 0.5 A [0.7 A]			LPT44
		5 V @ 4 A [5 A]	15 V @ 2 A [2.5 A]	-15 V @ 0.5 A [0.7 A]			LPT45
		5 V @ 4 A [5 A]	24 V @ 1 A [1.5 A]	+12 V @ 0.5 A [0.7 A]			LPT46
		5 V @ 4 A [5 A]	24 V @ 1 A [1.5 A]	-12 V @ 0.5 A [0.7 A]		LPT47	
[55 W]	45 W	NPT40-M Series**				2" x 4" x 1" (50.8 x 101.6 x 25.4)	NPT42-M
		5 V @ 5 A [8 A]	12 V @ 2.5 A [3 A]	-12 V @ 0.5 A [0.7 A]			NPT43-M
		5 V @ 5 A [8 A]	15 V @ 2 A [2.4 A]	-15 V @ 0.5 A [0.7 A]			NPT44-M
		5 V @ 5 A [8 A]	24 V @ 1 A [1.5 A]	12 V @ 0.5 A [0.7 A]			

Options:

[] Rating with 30 CFM of air

(1) Optional cover/enclosure

* Floating output

** This product is a component power supply and is only for inclusion by professional installers within other equipment and must not be operated as a standalone product. EMC compliance to appropriate standards must be verified at the system level. This product is for sale to OEMs and system integrators, including through distribution channels. It is not intended for sale to end users.

Output Power		Output				Size W x L x H (mm)	Model	
[Forced Air]	Free Air	V1	V2	V3	V4			
[60 W]	45 W	NPS40-M Series**						
		5 V @ 8 A [11 A]*				2" x 4" x 1"	NPS42-M	
		12 V @ 3.75 A [5 A]*				(50.8 x 101.6 x 25.4)	NPS43-M	
		15 V @ 3 A [4 A]*					NPS44-M	
		24 V @ 1.9 A [2.5 A]*					NPS45-M	
		48 V @ 0.94 A [1.25 A]*					NPS48-M	
[60 W]	60 W	NPS60-M Series**						
		5 V @ 11 A*				2" x 4" x 1"	NPS62-M	
		12 V @ 5 A*				(50.8 x 101.6 x 25.4)	NPS63-M	
		12 V @ 5 A* (Level VI Efficiency)					NPS63-M-006	
		15 V @ 4 A*					NPS64-M	
		24 V @ 2.5 A*					NPS65-M	
[75 W]	65 W	NLP65 Series**						
		5 V @ 12 A*				3" x 5" x 1.26"	NLP65-9605J ^{(5)(G)}	
		12 V @ 6.5 A*				(76.2 x 127 x 32)	NLP65-9612J ^{(5)(G)}	
		24 V @ 3.5 A*					NLP65-9624J ^{(5)(G)}	
		5 V @ 8 A	12 V @ 3 A				NLP65-9629J ^{(5)(G)}	
		5 V @ 8 A	12 V @ 3 A	-12 V @ 0.8 A			NLP65-9608J ^{(5)(E,G)}	
		5 V @ 8 A	15 V @ 2.5 A	-15 V @ 0.8 A			NLP65-9610J ^{(5)(G)}	
		5 V @ 8 A	24 V @ 2 A				NLP65-9620J ^{(5)(G)}	
[80 W]	60 W	LP60 Series**						
		3.3 V @ 12 A [16 A]*				3" x 5" x 1.65"	LPS61	
		5 V @ 12 A [16 A]*				(76.2 x 127 x 41.9)	LPS62	
		12 V @ 5 A [6.7 A]*					LPS63	
		15 V @ 4 A [5.3 A]*					LPS64	
		24 V @ 2.5 A [3.3 A]*					LPS65	
		48 V @ 1.3 A [1.7 A]*					LPS68	
		3.3 V @ 5 A [8.5 A]	5 V @ 2.5 A [3 A]	+12 V @ 0.5 A [1 A]			LPT61	
		5 V @ 7 A [8 A]	12 V @ 3 A [3.5 A]	-12 V @ 0.7 A [1 A]			LPT62	
		5 V @ 7 A [8 A]	15 V @ 2.8 A [3.3 A]	-15 V @ 0.7 A [1 A]			LPT63	
		5 V @ 7 A [8 A]	12 V @ 3 A [3.5 A]	-5 V @ 0.7 A [1 A]			LPT64	
		5 V @ 7 A [8 A]	24 V @ 1.5 A [2 A]	+12 V @ 0.7 A [1 A]			LPT65	
[130 W]	80 W	LPT100-M Series**						
		3.3 V @ 13 A [18 A]	5 V @ 5 A [9 A]	12 V @ 1 A [2.3 A]			2" x 4" x 1.28"	LPT101-M
		5 V @ 13 A [18 A]	12 V @ 5 A [9 A]	-12 V @ 1 A [2 A]			(50.8 x 101.6 x 32.7)	LPT102-M
		5 V @ 13 A [18 A]	15 V @ 4 A [7.2 A]	-15 V @ 1 A [1.5 A]				LPT103-M
		5 V @ 13 A [18 A]	24 V @ 1.5 A [3 A]	12 V @ 1 A [2.3 A]				LPT104-M

Options:

[] Rating with 30 CFM of air

(1) Optional cover/enclosure

* Floating output

(-I) Industrial version -40 °C up to 80 °C (derated)

** This product is a component power supply and is only for inclusion by professional installers within other equipment and must not be operated as a standalone product. EMC compliance to appropriate standards must be verified at the system level. This product is for sale to OEMs and system integrators, including through distribution channels. It is not intended for sale to end users.

(E) To order an enclosed version of the NLP65-9608J, add suffix 'EJ' to the end of the model number, e.g., NLP65-9608EJ. The enclosed version includes: IEC connector, on/off switch, wire harness output connector and fitted cover.

(G) A safety earth ground pin and ground choke are available as an option. To order, please add the suffix 'GJ' to the end of the model number e.g. NLP65-9612GJ.

(5) These modules feature harmonic current correction to EN61000-3-2

Output Power		Output				Size W x L x H (mm)	Model	
[Forced Air]	Free Air	V1	V2	V3	V4			
[150 W]  (1)	100 W	TLP150 Series**						
			12 V @ 12.5 A*				3" x 5" x 1.25"	TLP150R-96S12J ^(P)
			24 V @ 6.3 A*				(76.2 x 127 x 31.75)	TLP150R-96S24J ^(P)
			36 V @ 4.2 A*					TLP150R-96S36J
			48 V @ 3.2 A*					TLP150R-96S48J ^(P)
[150 W]  (1)	100 W	LPS100-M Series**						
			5 V @ 16 A [24 A]*				2" x 4" x 1.29"	LPS102-M
			12 V @ 8.3 A [12.5 A]*				(50.8 x 101.6 x 33)	LPS103-M
			15 V @ 6.7 A [10 A]*					LPS104-M
			24 V @ 4.2 A [6.3 A]*					LPS105-M
			48 V @ 2.1 A [3.1 A]*					LPS108-M
			54 V @ 1.85 A [2.8 A]*					LPS109-M
[175 W]  (1)	110 W	LP170 Series**						
			5 V @ 22 A [35 A]* (2.5-6 V)				4.25" x 8.5" x 1.5" (108 x 215.9x 38.1)	LPS172
			12 V @ 9.1 A [15 A]* (6-12 V)					LPS173
			15 V @ 7.3 A [12 A]* (12-24 V)					LPS174
			24 V @ 4.5 A [7.5 A]* (24-54 V)					LPS175
			5 V @ 15 A [30 A] (3.3-5.5 V)	12 V @ 6 A [8 A]	-12 V @ 0.2 A [3 A] (-12-15 V)	±3.3-25 V @ 2 A [5 A]*		LPQ172
			5 V @ 10 A [24 A] (3.3-5.5 V)	12 V @ 6 A [8 A]	-12 V @ 1.2 A [3 A] (-12-15 V)	5 V @ 10 A [24 A]* (3.3-5 V)		LPQ173
[200 W]  (1)	100 W	LPQ200-M Series**						
			3.3 V @ 13 A [18 A]	5 V @ 13 A [18 A]	12 V @ 5 A [9 A]	-12 V @ 1 A [2 A]	3" x 5" x 1.32"	LPQ201-M
			5 V @ 13 A [18 A]	12 V @ 5 A [9 A]	24 V @ 1.5 A [3 A]	-12 V @ 1 A [2 A]	(76.2 x 127 x 33.6)	LPQ202-M
[250 W]  (1)	125 W	LPS200-M Series**						
			5 V @ 20 A [40 A]*				3" x 5" x 1.32"	LPS202-M
			12 V @ 10.3 A [20.8 A]*				(76.2 x 127 x 33.6)	LPS203-M
			15 V @ 8.3 A [16.6 A]*					LPS204-M
			24 V @ 5.2 A [10.4 A]*					LPS205-M
			48 V @ 2.6 A [5.2 A]*					LPS208-M

Options:

[] Rating with 30 CFM of air

(1) Optional cover/enclosure

* Floating output

** This product is a component power supply and is only for inclusion by professional installers within other equipment and must not be operated as a standalone product. EMC compliance to appropriate standards must be verified at the system level. This product is for sale to OEMs and system integrators, including through distribution channels. It is not intended for sale to end users.

Output Power		Output				Size W x L x H (mm)	Model
[Forced Air]	Free Air	V1	V2	V3	V4		
[250 W]	155 W	CPS250-M Series**					
		12 V @ 12.92 A [20.83 A]				2" x 4" x 1.3"	CPS253-M
		24 V @ 6.45 A [10.42 A]				(50.8 x 101.6 x 32.8)	CPS255-M
		48 V @ 3.23 A [5.21 A]					CPS258-M
[250 W]	175 W	NLP250 Series**					
(1) 		12 V @ 21 A*				4" x 7" x 1.5"	NLP250R-96S12J
		24 V @ 10.5 A*				(101.6 x 177.8 x 38.1)	NLP250R-96S24J
		48 V @ 5.3 A*					NLP250R-96S48J
		NLP250 – DC (-48 Vdc Input)**					
		12 V @ 14.6 A [21 A]				4" x 7" x 1.5"	NLP250N-48S12J
[350 W]		LP350 Series**					
		5 V (3-6 V) @ [70 A]*				5" x 9" x 2.5"	LPS352-C
		12 V (6-12 V) @ [29.2 A]*				(127 x 228.6 x 63.5)	LPS353-C
		15 V (12-24 V) @ [23.3 A]*					LPS354-C
		24 V (24-48 V) @ [14.6 A]*					LPS355-C
[360 W]	240 W	LPS360-M Series**					
		12 V @ 20 A [30 A]*				3" x 5" x 1.3"	LPS363-M
		15 V @ 16 A [24 A]*				(76.2 x 127 x 33)	LPS364-M
		24 V @ 10 A [15 A]*					LPS365-M
		36 V @ 6.25 A [11.25 A]*					LPS366-M
		48 V @ 5 A [7.5 A]*					LPS368-M
[650 W]	400 W	CNS650 Series**					
		12 V @ 54.2 A				4" x 7" x 1.6"	CNS653-ME
		12 V @ 54.2 A [30.8 A]				3.8" x 6" x 1.3"	CNS653-MF
		12 V @ 54.2 A [33.3 A]				4" x 6" x 1.5"	CNS653-MU
		24 V @ 27.1 A [16.7 A]				(101.6 x 152.4 x 39)	CNS655-MU
		48 V @ 13.5 A [8.3 A]					CNS658-MU

Options:
 [] Rating with 30 CFM of air
 (1) Optional cover/enclosure
 * Floating output

** This product is a component power supply and is only for inclusion by professional installers within other equipment and must not be operated as a standalone product. EMC compliance to appropriate standards must be verified at the system level. This product is for sale to OEMs and system integrators, including through distribution channels. It is not intended for sale to end users.



CPS250-M

Open Frame

250 Watts AC-DC Power Supply

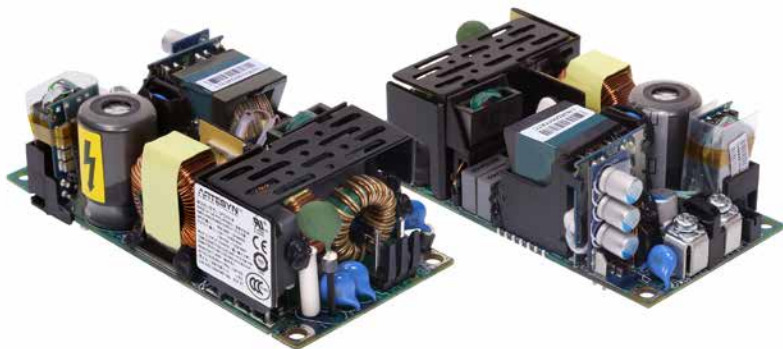

Total Power: 250 W
 # of Outputs: Single
 Output: 12 to 48 V
 12 V Fan Output

Special Features

- Up to 250 W forced air, 155 W natural convection
- 2" x 4" x 1.29" Open Frame Package
- Class I and II operation
- < 500 mW no-load power consumption
- +10% Output adjustment
- 12 V Fan Output
- Overvoltage; Overcurrent; Over temperature protection
- Start up at -40 °C ambient temperature
- Medical and ITE Safety Approvals
- 2X MOPP, Type BF Ready
- High Efficiency: 93% Typical
- > 2.2 Mhrs MTBF
- 3 Yrs Warranty
- LPX100 enclosure kit available

Electrical Specifications

Input	
Input Range	90-264 VAC
Frequency	47-63 Hz (360-440 Hz)
Inrush Current	70 Apk < 1ms (cold start)
Efficiency	93% Typical
Input Fusing	Internal 6.3 A fuses on L and N lines.
No Load Power	< 500 mW
Leakage Current	Meets Medical Leakage for both Class I and II
Power Factor and Harmonics	0.99 typical; meets EN61000-3-2
Hold Up Time	10 ms @ 225 W

Environmental Specifications

Operating Temperature	-20 to 70 °C (-40 °C Start up)
Storage Temperature	-40 to 85 °C
Humidity	5% to 90% non-condensing
Altitude	Operating: Up to 5,000m (3,000 for medical) Non-Operating: Up to 16,000m

Safety

TUV	60950-1 / 60601-1
UL/CSA	60950-1 / 60601-1
CB	IEC 60950-1 / IEC 60601-1
CE	EN60601-1-2 / LVD / RoHS
CCC	



Electrical Specifications

Output Rating	See ordering information below	
Fan Output	12 V @ 500 mA	J2 connector
Output Set Point	±0.5%	Factory set point
Regulation Range	Main Output: ±2% 12 V Fan Output	Combined set point; line and load variations measured at output pins.
Maximum Power	250 W Forced Air (~300 LFM) 155 W Natural Convection (100% power up to 50 °C)	Default VR2 position is for forced air operation. Adjust VR2 full counter clockwise for Natural Convection operation.
Peak Current during Natural Convection	+20% of Max Continuous Load Current (natural convection)	Peak should be < 30 s with max duty cycle of 10%.
Output Adjustability	-0% / +10%	Adjust via VR1 Trimpot
Overvoltage protection (OVP)	130% to 150% of nominal output	Latching; requires AC recycle to restart
Overcurrent protection (OCP)	Forced Air: 110% typical Natural Convection: 135% typical	Shutdown; autorecovery
Short Circuit Protection	< 50 mOhm	Shutdown; autorecovery
Over Temperature protection (OTP)	Refer to TRN for component hot spots and temperature limits.	Shutdown; autorecovery with hysteresis.
Isolation Voltage	4000 Vac (input to output) 1500 Vac (input to PE; output to PE)	
5 V Standby Output (-M1 Option)	100 mA	Available on 12 V model (CPS253-M1) only.

Ordering Information

Model Number	Output Voltage	Minimum Load	Max. Continuous Load (Free Air)	Peak Load (Free Air) ¹	Max. Continuous Load (Forced Air) ²	Regulation	Ripple (p-p)
CPS253-M	12 V	0 A	12.92 A	15.5 A	20.83 A	±2%	120 mV
CPS253-M1	12 V	0 A	12.92 A	15.5 A	20.83 A	±2%	120 mV
CPS255-M	24 V	0 A	6.45 A	7.74 A	10.42 A	±2%	240 mV
CPS258-M	48 V	0 A	3.23 A	3.88 A	5.21 A	±2%	480 mV

1. Peak load current not to exceed 30 seconds with maximum 10% duty cycle.

2. Requires at least 300 LFM of airflow.

Consult the Technical Reference Notes for complete specifications



CNS650-MU

Open Frame

650 Watts AC-DC Power Supply

Total Power: 650 W
 # of Outputs: Single
 Output: 12 to 48 V
 5 V Standby
 12 V Fan Output



Special Features

- Up to 650 W forced air, 400 W natural convection
- 4" x 6" x 1.54" U-channel construction
- < 500 mW no-load power consumption
- +15% Output Adjust
- 5 V Standby Output
- 12 V Fan Output
- Power_OK; VIN_Good; Remote Inhibit; Fan_Fail; Fan_Tachco; Remote Sense
- Overvoltage; Overcurrent; Over temperature protection
- Start up at -40 °C ambient temperature
- Medical and ITE Safety Approvals
- 2X MOPP, Type BF Ready
- High Efficiency: 93% Typical
- Active Current Share / Built in ORing
- Digital I²C / PMBus protocol
- > 1.3 Mhrs MTBF
- 3 Yrs Warranty
- 80 PLUS certified (-ME model)

Electrical Specifications

Input	
Input Range	90-264 VAC 127-350 VDC
AC Input Turn-On	87-90 VAC
VAC Input Turn-Off	80-82 VAC
Frequency	47-63 Hz (360-440 Hz)
Inrush Current	50 Apk (cold start)
Efficiency	93% Typical 100% Load
Input Fusing	Internal 12 A fuses on L and N lines.
No Load Power	< 500 mW -Main Output Disabled
Leakage Current	< 300 μA, 264 VAC, 60 Hz
Power Factor and Harmonics	0.99 typical; meets EN61000-3-2
Hold Up Time	25 ms @ 400 W

Environmental Specifications

Operating Temperature	-20 to 80 °C (-40 °C Start up)
Storage Temperature	-40 to 85 °C
Humidity	5% to 95% non-condensing
Altitude	Operating: Up to 5,000m (3,000 for medical) Non-Operating: Up to 10,000m

Safety

TUV	EN60601-1
UL/CSA	60950-1 / 60601-1
CB	IEC 60950-1 / IEC 60601-1 / IEC 62368-1
CE	EN60601-1-2 / LVD / RoHS
DEMKO	EN60950-1
CCC	

Electrical Specifications

Output Rating	See ordering information below	
5 V Standby Output	5 V @ 1 A (Nat Convection) 5 V @ 2 A (Forced Air)	J304
Fan Output	12 V @ 0.5 A (Nat Convection) 12 V @ 1.0 A (Forced Air)	J306 or J304
Regulation Range	Main Output: $\pm 2\%$ 12 V Fan Output	Combined set point; line and load variations measured at output pins.
Maximum Power	650 W Forced Air (~400 LFM) 400 W Nat Convection (-MU Suffix) 360 W Nat Convection (-MF Suffix)	Power Derating applies > 50 °C ambient
Peak Load	750 W Forced Air (~400 LFM)	Any duty cycle for as long as Pout Average \leq 650W
Output Adjustability	-0% / +15%	Adjust via VR408 Trimpot
Overvoltage protection (OVP)	130% to 150% of nominal output	Latching; requires AC recycle to restart
Overcurrent protection (OCP)	115% to 170% of Rated Output Current	Constant current up to 50% of rated O/P Voltage then goes to hiccup mode. Autorecovers when fault is removed.
Short Circuit Protection	< 50 mOhm	Hiccup/Non Latching; autorecovery
Over Temperature protection (OTP)	Refer to TRN for component hot spots and temperature limits.	Shutdown; autorecovery with hysteresis.
Isolation Voltage	4000 Vac (input to output) 1500 Vac (input to PE; output to PE)	

Ordering Information

Model Number	Output Voltage	Vout Adjust Range (-0%/+15%)	Minimum Load	Max. Continuous Load (Free Air)	Max. Peak Load (Free Air) ¹	Max. Continuous Load (Forced Air) ²	Max. Peak Load (Forced Air) ²	Regulation ³	Ripple (p-p) ⁴
CNS653-ME ^{5,6}	12 V	12-13.8 V	0 A	54.2 A	62.5 A	NA	NA	$\pm 2\%$	120 mV
CNS653-MF ⁵	12 V	12-13.8 V	0 A	30.0 A	54.2 A	54.2 A	62.5 A	$\pm 2\%$	120 mV
CNS653-MU	12 V	12-13.8 V	0 A	33.3 A	54.2 A	54.2 A	62.5 A	$\pm 2\%$	120 mV
CNS655-MU	24 V	24-27.6 V	0 A	16.7 A	27.1 A	27.1 A	31.3 A	$\pm 2\%$	240 mV
CNS658-MU	48 V	48-55.2 V	0 A	8.3 A	13.5 A	13.5 A	15.6 A	$\pm 2\%$	480 mV

1. Peak load current not to exceed 10 seconds, Ta = 50 °C.

2. Requires at least 400 LFM of airflow.

3. At 25 °C including factory setpoint, line voltage and load current variations.

4. Peak-to-peak ripple measured at the output terminal with 20 MHz bandwidth and 10 μ F (tantalum capacitor) in parallel with 0.1 μ F capacitor across the output.

5. Optional suffix "-ME" (end-fan) and "-MF": (open-frame) available on the 12 V output.

6. 80 PLUS certified.

Consult the Technical Reference Notes for complete specifications

LCC250

Convection/conduction
mounting

250 Watts

Total Power: 250 Watts
of Outputs: Single
Output: 12 V, 24 V, 48 V



Special Features

- Wide operating temperature range suited for both outdoor and indoor applications
- 250 W fanless power supply with zero derating up to 85 °C baseplate
- IP64 rated enclosure
- Conduction or convection mounting
- Differential remote sense
- Output adjust
- Output On/Off (Positive or negative logic user selectable)

Electrical Specifications

Input	
Input range	90-264 Vac (Operating) 115/230 Vac (Nominal)
Frequency	47-63 Hz
Input fusing	Internal fuse on both L and N lines
Inrush current	50 A
Power factor	> 0.92 full load
Harmonics	Meets EN61000-3-2; MIL-STD-461E: CE101; CE102 ⁴ ; CS101; CS104
Input current	3.4 A @ 90 Vac full load
Hold up time	16 ms minimum at 115 Vac; 100% load
Efficiency	230 Vac; 100% load 12 V - 89% typical 24 V - 91% typical 48 V - 91.5% typical
Leakage current	< 275 µA at 230 Vac



Environmental Specifications

Operating temperature	Suffix 4P (conduction): -40 °C to +85 °C baseplate temperature Suffix 7P (convection): -40 °C to +85 °C ambient temperature
Storage temperature	-40 °C to 85 °C
Humidity	10% to 100% (condensing & non-condensing)
Altitude	Operating: 13,000 feet Non-operating: 50,000 feet
Shock	IEC 68-2-27
Vibration	IEC 68-2-6 / IEC 721-3-2
Ingress protection	IP64 rated
MTBF (calculated)	> 780,000 hours at 100% load; Low line; Telcordia SR332

Compliance

EMI Class B
EN61000 Immunity

Safety

UL + CSA	60950-1 ANSI ES60601-1 3rd Ed.
TÜV	60950-1 60601-1 61347-1; 2-13
China	CCC ³
CB Scheme	IEC 60950-1 IEC 61347-1; 2-13 IEC 60601-1

Electrical Specifications

Output		
Output rating	12 V @ 20.83 A 24 V @ 10.4 A 48 V @ 5.2 A	—
Set point	±0.2%	Factory set point
Total regulation range	±2%	Line/load/temperature
Rated load	250 W maximum	—
Minimum load	0 A Load	No loss of regulation
Capacitive load	0-330 μF/amp	—
Constant output voltage adjustment range	12 V: +10/-10% 24 V: +14.6/-15% 48 V: +15%/-15%	Adjust via VR2
Constant output current adjustment range	+0/-50%	Adjust via VR1 CC mode supported from Vo nominal down to 80% Vo
Output ripple and noise	1%	See Note 1
Transient response	±5% Vo max transient; recovery < 500 μs max	50% load step @ 1 A/μs Step load verified at: 50% to 100% load; 90-264 Vac input; capacitive load from 0 to 330 μF/Amp
Remote sense	Capable of stable offset of ±0.5 Vdc at output cable termination	+SENSE (red wire); -SENSE (black wire)
Output On/Off	Remote on/off referenced to secondary side. Positive or negative logic user selectable via CN2. Factory default is positive logic.	On/off (orange wire); on/off return (white wire)
Overload protection (OCP)	< 150% Io	Autorecovery
Overvoltage protection (OVP)	110% to 135% Vo	Latching mode; requires input AC recycle
Overtemp protection (OTP)	—	Autorecovery; hiccup mode
Output isolation	4000 Vac Input to Output 1500 Vac Input to Ground 500 Vac Output to Ground	—

Ordering Information

Model Number	Output	Adjustment Range	Output Current		Output Ripple P/P ¹	Combined Line/ Load Regulation
			Min	Max		
LCC250-12U-4P	12 V	±10%	0 A	20.8 A	1%	±2%
LCC250-12U-4PE ³	12 V	±10%	0 A	20.8 A	1%	±2%
LCC250-12U-7P	12 V	±10%	0 A	20.8 A	1%	±2%
LCC250-12U-7PE ³	12 V	±10%	0 A	20.8 A	1%	±2%
LCC250-24U-4P	24 V	+14.6/-15%	0 A	10.4 A	1%	±2%
LCC250-24U-4PE ³	24 V	+14.6/-15%	0 A	10.4 A	1%	±2%
LCC250-24U-7P	24 V	+14.6/-15%	0 A	10.4 A	1%	±2%
LCC250-24U-7PE ³	24 V	+14.6/-15%	0 A	10.4 A	1%	±2%
LCC250-48U-4P	48 V	±15%	0 A	5.2 A	1%	±2%
LCC250-48U-4PE ³	48 V	±15%	0 A	5.2 A	1%	±2%
LCC250-48U-7P	48 V	±15%	0 A	5.2 A	1%	±2%
LCC250-48U-7PE ³	48 V	±15%	0 A	5.2 A	1%	±2%

1. Output ripple measured at the end of the output cable terminated with 10 μF tantalum capacitor in parallel with 0.1 μF ceramic capacitor.
2. Additional external capacitance required to meet the indicated Output Ripple Limits. Please check the Technical Reference Notes.
3. China CCC approval applies to part numbers with "-xxE" suffixes only.
4. 12 V output compliance to CE102 requires external filter. Consult Technical Reference Notes.

LCC600

Convection/conduction
mounting

600 Watts

Total Power: 600 Watts
of Outputs: Single
Output: 12, 28, 36, 48 V



Special Features

- Baseplate cooled
- -40 to 85 °C operating baseplate temperature
- No derating up to 85 °C baseplate temperature
- Adjustable output
- 10.6 watts per cubic inch
- Differential remote sense
- EMI Class B
- With +5V standby @ 1.5A
- Full DSP controlled
- Optional IP65 ("-4P" suffix) variant
- Optional 277 VAC nominal input ("H" suffix) variant
- Active Ishare
- PMBus
- Industrial/Medical safety (Suited for BF Type applications)

Electrical Specifications

Input	
Input range	90-264 VAC (U version) 180-305 VAC (H version)
Frequency	50/60/440 Hz (Agency Approval 47-63 Hz)
Input fusing	12.5 A RMS on both input lines (U Suffix)
Inrush current	< 25 A peak
Power factor	0.99 typical
Harmonics	Meets EN61000-3-2, Class A and C MIL-STD-461F EMI: CE101, CE102, CS101, CS114, CS115 (w/ ext filter)
Input current	< 10 Arms max at 100 VAC
Hold up time	20 ms (main O/P @ 230 Vac)
Isolation	PRI-SEC: 4kVAC (2X MOPP) PRI-CASE: 1.5kVAC (1X MOPP) SEC-CASE: 1.5kVAC (1X MOPP)

Environmental Specifications

Operating Temperature	-40 to 85 °C baseplate
Humidity	10% to 95%
Altitude	16,402 feet (5,000m) operating
Shock	MIL-STD-810F 516.5 Procedure I, VI
Vibration	MIL-STD-810F 514.5 CAT 4, 10
IP Rating	Optional IP65 rated enclosure ("4P" suffix)
MTBF	> 2 Mhrs, 25 °C per SR-332 Issue 3

Safety

UL + CSA	60950-1 / 60601-1 3rd Ed
TUV	60950-1 / 60601-1
China	CCC
CB Scheme	60950-1 / 60601-1 Certs
UL 8750 / TUV EN 61347-1; -2-13 / IEC 61347-1; -2-13 (48 V output)	

Ordering Information

Model Number*	AC Input	Output Setpoint	Setpoint Tolerance	Adjustment Range	Output Current [A]		Max O/P Power [W]	Typical Efficiency **	Standby Output	Combined Line/Load Regulation	Output Ripple
					Min	Max					
LCC600-48U-9P	90 - 264	48 V	±0.5%	44 - 54	0	12.5	600	93%	5 VDC @ 1.5 A	2%	1%
LCC600-48H-9P	180 - 305	48 V	±0.5%	44 - 54	0	12.5	600	93%	5 VDC @ 1.5 A	2%	1%
LCC600-36U-9P	90 - 264	36 V	±0.5%	32 - 38	0	16.7	600	92%	5 VDC @ 1.5 A	2%	1%
LCC600-36H-9P	180 - 305	36 V	±0.5%	32 - 38	0	16.7	600	92%	5 VDC @ 1.5 A	2%	1%
LCC600-28U-9P	90 - 264	28 V	±0.5%	24 - 30	0	25	600	93.5%	5 VDC @ 1.5 A	2%	1%
LCC600-28H-9P	180 - 305	28 V	±0.5%	24 - 30	0	25	600	93.5%	5 VDC @ 1.5 A	2%	1%
LCC600-12U-9P	90 - 264	12 V	±0.5%	12 - 15	0	50	600	92%	5 VDC @ 1.5 A	2%	1%
LCC600-12H-9P	180 - 305	12 V	±0.5%	12 - 15	0	50	600	92%	5 VDC @ 1.5 A	2%	1%

* Change suffix "-9P" to "-4P" for IP65 rated enclosure with fly lead wires.

* Change suffix "-4P" to "-4PR" for IP65 rated enclosure with right angle fly lead wires (applies to 28 V, 36 V, 48 V).

* Change suffix "-4P" to "-4PV" for cables without control signal (applies to 28 V, 36 V and 48 V).

** Typical Efficiency at high line, factory default voltage and full load.

*** When the output voltage is set as low as 24 V, it can provide a current of up to 25 A (the maximum power is 600 W). At the default output voltage of 28 V, the output current is up to 21.43 A (the maximum power is 600 W).

Low Power

External power adapters

3-100 Watts

Special Features

All models feature:

- Wide-range AC input
- High demonstrated MTBF
- Overload protection
- Extensive safety approvals

Many models feature:

- EN61000-3-2 compliance
- Medical approvals
- Thermal protection
- Energy Star/ErP
- DoE Level VI
- EU CoC v5 Tier 2

AC Input:

- Wallmount
 - U.S. – 2-prong
 - China – 2-prong
 - Europe – 2-prong
 - United Kingdom – 3-prong
 - Australia – 2-prong
 - Korea – 2-prong
 - Japan – 2-prong
 - Interchangeable
- Freestanding
 - IEC320 2-pin (C14) & (C6)
 - IEC320 2-pin (C8)

DC Output:

- Single output
 - 2.5 mm barrel plug
 - 2.1 mm right angle plug



Output Power

3 W



	V1	V2	V3	Size W x L x H (mm)	Model
DCH3 Series – USB (Level VI)					
5 V @ 0.55 A				1.03" x 2.28" x 2.56" (26.1 x 58 x 65)	DCH3-050EU-0005 DCH3-050EU-0006
5 V @ 0.55 A				2.02" x 2.28" x 1.79" (51.2 x 58 x 46)	DCH3-050UK-0005 DCH3-050UK-0006
5 V @ 0.55 A				1.03" x 2.29" x 2.44" (26.1 x 58 x 62)	DCH3-050US-0005 DCH3-050US-0006

5 W



	DA5 Series (Level VI)				
5 V @ 1 A				1.73" x 1.57" x 0.98" (44 x 40 x 25)	DA5-050US-B DA5-050US-W
5 V @ 1 A				2.48" x 1.57" x 0.98" (63 x 40 x 25)	DA5-050EU-B
5 V @ 1 A				1.93" x 1.65" x 2.17" (49 x 42 x 55)	DA5-050UK-B
5 V @ 1 A				1.73" x 1.57" x 0.98" (44 x 40 x 25)	DA5-050CH-B

10 W



	DA10 Series (Level VI)				
5 V @ 2 A				1.73" x 1.57" x 0.98" (44 x 40 x 25)	DA10-050US
5 V @ 2 A				1.73" x 1.57" x 0.98" (44 x 40 x 25)	DA10-050CH
5 V @ 2 A				2.48" x 1.57" x 0.98" (63 x 40 x 25)	DA10-050EU
5 V @ 2 A				1.93" x 1.65" x 2.17" (49 x 42 x 55)	DA10-050UK

Output Power	V1	V2	V3	Size W x L x H (mm)	Model
10 W 	DA10-M Series (Level VI)				
	5 V @ 2 A			1.10" x 2.36" x 2.14" (28 x 60 x 54.3)	DA10-050AU-M
	5 V @ 2 A			1.10" x 2.36" x 2.48" (28 x 60 x 63.1)	DA10-050EU-M
	5 V @ 2 A			1.98" x 2.36" x 1.90" (50.2 x 60 x 48.3)	DA10-050UK-M
	5 V @ 2 A			1.10" x 2.36" x 1.99" (28 x 60 x 50.6)	DA10-050US-M
	5 V @ 2 A			1.1" x 2.36" x 2.06" (28 x 60 x 52.3)	DA10-050MP-M ⁽¹⁾
	5 V @ 2 A			1.1" x 2.36" x 2.06" (28 x 60 x 52.3)	DA10-050MP-M2.1 ⁽²⁾
	5 V @ 2 A			1.1" x 2.36" x 2.06" (28 x 60 x 52.3)	DA10-050MP-M402 ⁽³⁾
24 W 	AD24 (Level VI)				
12 V @ 2 A			1.89" x 4.13" x 1.3" (48 x 105 x 33)	AD2412N3L-VI	
40 W 	DP40 Series (Level V only)				
	9 V @ 4.4 A			2.4" x 4.88" x 1.55"	DP4009N2M
	9 V @ 4.4 A			(61 x 124 x 39.5)	DP4009N3M
	12 V @ 3.33 A				DP4012N2M
	12 V @ 3.33 A				DP4012N3M
	15 V @ 2.67 A				DP4015N2M
	15 V @ 2.67 A				DP4015N3M
	18 V @ 2.22 A				DP4018N2M
	18 V @ 2.22 A				DP4018N3M
	24 V @ 1.67 A				DP4024N2M
	24 V @ 1.67 A				DP4024N3M
	48 V @ 0.84 A				DP4048N2M
	48 V @ 0.84 A				DP4048N3M
45 W 	DA45C Series (45 Watts USB PD 3.0 Type C, Level VI)				
	5 V @ 3 A / 9 V @ 3 A / 15 V @ 3 A / 20 V @ 2.25 A	(Single Output, Changeable)		2.28" x 1.58" x 1.06"	DA45C-J3WUS
	5 V @ 3 A / 9 V @ 3 A / 15 V @ 3 A / 20 V @ 2.25 A	(Single Output, Changeable)		(58 x 40.2 x 27)	DA45C-J3WCH
5 V @ 3 A / 9 V @ 3 A / 15 V @ 3 A / 20 V @ 2.25 A	(Single Output, Changeable)			DA45C-J3WEU	
100 W 	DP100 Series (Level VI & PoE Isolation)				
54 V @ 1.85 A			6.14" x 2.56" x 1.46" (156 x 65 x 37.2)	DP10054P3L	

Options:

(1) Interchangeable AC plug - must be purchased separately

(2) 2.1 mm x 5.5 mm barrel plug

(3) µUSB connector

NOTE:

Level V products may only be imported into the U.S.A. after February 10, 2016 with valid exemptions to Federal Regulations.

Healthcare AC–DC Power Supplies

Up to 24,000 Watts

Artesyn Embedded Power produces a wide range of AC–DC power supplies certified for use in medical equipment requiring lower safety ground leakage and higher isolation. The power supplies listed below are designed for use in non-patient critical applications: bio-life science, medical, dental, imaging and laboratory applications such as immunoassay and in-vitro diagnostics machines, ultrasound and mass analyzers. All these power supplies are high efficiency switch-mode designs, and feature medical safety approval to EN60601-1.







Special Features

All models feature:

- Industry standard footprints
- Wide-range AC input
- Remote sense
- Adjustable outputs
- Power fail
- Full power to 50 °C
- High demonstrated MTBF
- Overvoltage protection
- Overload protection
- Built-in EMI filtering
- Medical approvals
- Extensive safety approvals
- Derated operation to 70 °C







Many models feature:

- EN61000-3-2 compliance
- Supervisory outputs (5 V/12 V)
- Wide-adjust floating 4th output
- Single wire current share
- Wide-adjust on single output models
- Voltage monitor/data logging
- Real-time parametric adjustment & control

Output Power [Forced Air]	Free Air	Output				Size W x L x H (mm)	Model
		V1	V2	V3	V4		
[40 W]  (1)	25 W	NPS20-M Series**					
		5 V @ 5 A [8 A]*				2" x 4" x 1"	NPS22-M
		12 V @ 2.1 A [3.3 A]*				(50.8 x 101.6 x 25.4)	NPS23-M
		15 V @ 1.7 A [2.7 A]*					NPS24-M
		24 V @ 1 A [1.8 A]*					NPS25-M
		48 V @ 0.52 A [0.84 A]*					NPS28-M
[55 W]  (1)	40 W	LP40-M Series**					
		5 V @ 8 A [11 A]*				3" x 5" x 1.2"	LPS42-M
		12 V @ 3.3 A [4.5 A]*				(76.2 x 127 x 30.5)	LPS43-M
		15 V @ 2.6 A [3.6 A]*					LPS44-M
		24 V @ 1.6 A [2.3 A]*					LPS45-M
		5 V @ 4 A [5 A]	12 V @ 2 A [2.5 A]	-12 V @ 0.5 A [0.7 A]			LPT42-M
5 V @ 4 A [5 A]	15 V @ 2 A [2.5 A]	-15 V @ 0.5 A [0.7 A]			LPT45-M		
[60 W]  (1)	45 W	NPS40-M Series**					
		5 V @ 8 A [11 A]*				2" x 4" x 1"	NPS42-M
		12 V @ 3.75 A [5 A]*				(50.8 x 101.6 x 25.4)	NPS43-M
		15 V @ 3 A [4 A]*					NPS44-M
		24 V @ 1.9 A [2.5 A]*					NPS45-M
48 V @ 0.94 A [1.25 A]*					NPS48-M		
[55 W]  (1)	45 W	NPT40-M Series**					
		5 V @ 5 A [8 A]	12 V @ 2.5 A [3 A]	-12 V @ 0.5 A [0.7 A]			NPT42-M
		5 V @ 5 A [8 A]	15 V @ 2 A [2.4 A]	-15 V @ 0.5 A [0.7 A]			NPT43-M
		5 V @ 5 A [8 A]	24 V @ 1 A [1.5 A]	12 V @ 0.5 A [0.7 A]			NPT44-M

Options:
 [] Rating with 30 CFM of air
 (1) Optional cover/enclosure
 * Floating output

** This product is a component power supply and is only for inclusion by professional installers within other equipment and must not be operated as a standalone product. EMC compliance to appropriate standards must be verified at the system level. This product is for sale to OEMs and system integrators, including through distribution channels. It is not intended for sale to end users.

Output Power		Output				Size W x L x H (mm)	Model	
[Forced Air]	Free Air	V1	V2	V3	V4			
[60 W]	60 W	NPS60-M Series**						
		5 V @ 11 A*				2" x 4" x 1"	NPS62-M	
		12 V @ 5 A*				(50.8 x 101.6 x 25.6)	NPS63-M	
		12 V @ 5 A* (Level VI Efficiency)						NPS63-M-006
		15 V @ 4 A*						NPS64-M
		24 V @ 2.5 A*						NPS65-M
[75 W]	65 W	NLP65 Series**						
		12 V @ 6.5 A*				3" x 5" x 1.26"	NLP65-9912J ⁽⁶⁾	
		15 V @ 5.3 A*				(76.2 x 27 x 32)	NLP65-9915J ⁽⁶⁾	
		24 V @ 3.5 A*					NLP65-9924J ⁽⁶⁾	
		5 V @ 8 A	24 V @ 2 A				NLP65-9920J ⁽⁶⁾	
		5 V @ 8 A	12 V @ 3 A		-12 V @ 1 A		NLP65-9908J ⁽⁶⁾	
[80 W]	60 W	LP60-M Series**						
		12 V @ 5 A [6.7 A]*				3" x 5" x 1.65"	LPS63-M	
		15 V @ 4 A [5.3 A]*				(76.2 x 127 x 41.9)	LPS64-M	
		24 V @ 2.5 A [3.3 A]*					LPS65-M	
		5 V @ 7 A [8 A]	12 V @ 3 A [3.5 A]		-12 V @ 0.7 A [1 A]		LPT62-M	
		5 V @ 7 A [8 A]	15 V @ 2.8 A [3.3 A]		-15 V @ 0.7 A [1 A]		LPT63-M	
[130 W]	80 W	LPT100-M Series**						
		3.3 V @ 13 A [18 A]	5 V @ 5 A [9 A]	12 V @ 1 A [2.3 A]		2" x 4" x 1.28"	LPT101-M	
		5 V @ 13 A [18 A]	12 V @ 5 A [9 A]	-12 V @ 1 A [2 A]		(50.8 x 101.6 x 32.7)	LPT102-M	
		5 V @ 13 A [18 A]	15 V @ 4 A [7.2 A]	-15 V @ 1 A [1.5 A]			LPT103-M	
		5 V @ 13 A [18 A]	24 V @ 1.5A [3 A]	12 V @ 1 A [2.3 A]			LPT104-M	
[150 W]	100 W	LPS100-M Series**						
		5 V @ 16 A [24 A]*				2" x 4" x 1.29"	LPS102-M	
		12 V @ 8.3 A [12.5 A]*				(50.8 x 101.6 x 33)	LPS103-M	
		15 V @ 6.7 A [10 A]*					LPS104-M	
		24 V @ 4.2 A [6.3 A]*					LPS105-M	
		48 V @ 2.1 A [3.1 A]*					LPS108-M	
		54 V @ 1.85 A [2.8 A]*					LPS109-M	
[150 W]	100 W	TLP150 Series**						
		12 V @ 12.5 A*				3" x 5" x 1.25"	TLP150N-99S12J ^F	
		24 V @ 6.3 A*				(177.8 x 101.6 x 31.75)	TLP150N-99S24J ^F	
[175 W]	110 W	LP170-M Series**						
		5 V @ 22 A [35 A]* (2.5-6 V)				4.25" x 8.5" x 1.5"	LPS172-M	
		12 V @ 9.1 A [15 A]* (6-12 V)				(108 x 215.9 x 38.1)	LPS173-M	
		15 V @ 7.3 A [12 A]* (12-24 V)					LPS174-M	
		24 V @ 4.5 A [7.5 A]* (24-54 V)					LPS175-M	

Options:

F Replace the 'J' at the end of the model number with 'FJ' when the optional standby output and/or remote ON/OFF control is required e.g., TLP150N-99S12FJ

[] Rating with 30 CFM of air

(1) Optional cover/enclosure (see datasheet for increased dimensions)

(5) These models feature harmonic current correction to EN61000-3-2

* Floating output

** This product is a component power supply and is only for inclusion by professional installers within other equipment and must not be operated as a standalone product. EMC compliance to appropriate standards must be verified at the system level. This product is for sale to OEMs and system integrators, including through distribution channels. It is not intended for sale to end users.

Output Power		Output						
[Forced Air]	Free Air	V1	V2	V3	V4	Size W x L x H (mm)	Model	
[200 W]	100 W	LPQ200-M Series**						
		3.3 V @ 13 A [18 A]	5 V @ 13 A [18 A]	12 V @ 5 A [9 A]	-12 V @ 1 A [2 A]	3" x 5" x 1.32"	LPQ201-M	
(1)		5 V @ 13 A [18 A]	12 V @ 5 A [9 A]	24 V @ 1.5 A [3 A]	-12 V @ 1 A [2 A]	(76.2 x 127 x 33.6)	LPQ202-M	
[250 W]	125 W	LPS200-M Series**						
		5 V @ 20 A [40 A]*				3" x 5" x 1.32"	LPS202-M	
(1)		12 V @ 10.3 A [20.8 A]*				(76.2 x 127 x 33.6)	LPS203-M	
		15 V @ 8.3A [16.6 A]*					LPS204-M	
		24 V @ 5.2 A [10.4 A]*					LPS205-M	
		48 V @ 2.6 A [5.2 A]*					LPS208-M	
[250 W]	155 W	CPS250-M Series**						
		12 V @ 12.92 A [20.83 A]				2" x 4" x 1.3"	CPS253-M	
		24 V @ 6.45 A [10.42 A]				(50.8 x 101.6 x 32.8)	CPS255-M	
		48 V @ 3.23 A [5.21 A]					CPS258-M	
[360 W]	240 W	LPS360-M Series**						
		12 V @ 20 A [30 A]*				3" x 5" x 1.3"	LPS363-M	
		15 V @ 16 A [24 A]*				(76.2 x 127 x 33)	LPS364-M	
		24 V @ 10 A [15 A]*					LPS365-M	
		36 V @ 6.25 A [11.25 A]*					LPS366-M	
		48 V @ 5 A [7.5 A]*					LPS368-M	
[250 W]	250 W	LCC250 Series						
		12 V @ 20.8 A				4" x 7" x 1.1"	See LCC250 section	
		24 V @ 10.4 A				(101.6 x 177.8 x 28)		
		48 V @ 5.2 A						
[600 W]	600 W	LCC600 Series						
		12 V @ 50.0 A				4" x 9" x 1.57"	See LCC600 section	
		28 V @ 21.4 A						
		36 V @ 16.7 A				(101.6 x 228.6 x 40)		
		48 V @ 12.5 A						
[650 W]	400 W	CNS650 Series**						
		12 V @ 54.2 A				4" x 7" x 1.6" (101.6 x 177.8 x 40.6)	CNS653-ME	
		12 V @ 54.2 A [30.8 A]				3.8" x 6" x 1.3" (101.6 x 152.4 x 34.1)	CNS653-MF	
		12 V @ 54.2 A [33.3 A]				4" x 6" x 1.5"	CNS653-MU	
		24 V @ 27.1 A [16.7 A]				(101.6 x 152.4 x 39)	CNS655-MU	
		48 V @ 13.5 A [8.3 A]					CNS658-MU	

Options:

- (1) Optional cover/enclosure
- (4) Optional top fan covers (see datasheet for increased dimensions)
- (5) Optional end fan cover (see datasheet for increased dimensions)

* Floating output

** This product is a component power supply and is only for inclusion by professional installers within other equipment and must not be operated as a standalone product. EMC compliance to appropriate standards must be verified at the system level. This product is for sale to OEMs and system integrators, including through distribution channels. It is not intended for sale to end users.

Output Power [Forced Air] Free Air	Output				Size W x L x H (mm)	Model
	V1	V2	V3	V4		
[300 W] 	LCM300 Bulk Front End				1.61" x 4.0" x 7.0" (4.09 x 101.6 x 177.8)	See LCM300 section
12-60 V	Single outputs					
[600 W] 	LCM600 Bulk Front End				4.5" x 7.5" x 2.4" (114.3 x 190.5 x 62)	See LCM600 section
12-60 V	Single outputs					
[1000 W] 	LCM1000 Bulk Front End				2.5" x 5.2" x 10.0" (63.5 x 132.1 x 254)	See LCM1000 section
12-52.8 V	Single outputs					
[1500 W] 	LCM1500 Bulk Front End				2.5" x 5.2" x 10.0" (63.5 x 132.1 x 254)	See LCM1500 section
12-52.8 V	Single outputs					
[3000 W] NEW! 	LCM3000 Bulk Front End				2.5" x 7.0" x 10.9"	See LCM3000 section
12-48 V	Single outputs					
Up to 1800 W 	Micro MP Series				3.5" x 10.11" x 1.57" (88.9 x 256.9 x 40)	See μMP section
1.8-60 V	1-12 outputs	(Fully Configurable)				
Up to 1500 W 	Intelligent MP Series				5" x 10" x 2.5" (127 x 254 x 63.5)	See iMP section
2-60 V	1-21 outputs	Fully configurable and intelligent				
1500-4920 W 	Intelligent VS Series				5" x 11" x 5" (127 x 279.4 x 127)	See iVS section
2-60 V	1-42 outputs	Fully configurable and intelligent				
Up to 24000 W NEW! 	Precision High Power System				5.22" x 19" x 27.9" (132.5 x 482.6 x 708.3)	See iHP Section
0.12-300 V	Up to 8 outputs	Fully configurable and intelligent				

Output Power	V1	V2	V3	Size W x L x H (mm)	Model
10 W 	DA10-M Series (Level VI)				
	5 V @ 2 A			1.10" x 2.36" x 2.14" (28 x 60 x 54.3)	DA10-050AU-M
	5 V @ 2 A			1.10" x 2.36" x 2.48" (28 x 60 x 63.1)	DA10-050EU-M
	5 V @ 2 A			1.98" x 2.36" x 1.90" (50.2 x 60 x 48.3)	DA10-050UK-M
	5 V @ 2 A			1.10" x 2.36" x 1.99" (28 x 60 x 50.6)	DA10-050US-M
	5 V @ 2 A			1.1" x 2.36" x 2.06" (28 x 60 x 52.3)	DA10-050MP-M ⁽¹⁾
	5 V @ 2 A			1.1" x 2.36" x 2.06" (28 x 60 x 52.3)	DA10-050MP-M2.1 ⁽²⁾
5 V @ 2 A			1.1" x 2.36" x 2.06" (28 x 60 x 52.3)	DA10-050MP-M402 ⁽³⁾	
40 W 	DP40 Series (Level V only)				
	9 V @ 4.4 A			2.4" x 4.88" x 1.55" (61 x 124 x 39.5)	DP4009N2M
	9 V @ 4.4 A				DP4009N3M
	12 V @ 3.33 A				DP4012N2M
	12 V @ 3.33 A				DP4012N3M
	15 V @ 2.67 A				DP4015N2M
	15 V @ 2.67 A				DP4015N3M
	18 V @ 2.22 A				DP4018N2M
	18 V @ 2.22 A				DP4018N3M
	24 V @ 1.67 A				DP4024N2M
	24 V @ 1.67 A				DP4024N3M
	48 V @ 0.84 A				DP4048N2M
	48 V @ 0.84 A				DP4048N3M

Options:

- (1) Interchangeable AC plug - must be purchased separately
- (2) 2.1 mm x 5.5 mm barrel plug
- (3) µUSB connector

NOTE:

Level V products may only be imported into the U.S.A. after February 10, 2016 with valid exemptions to Federal Regulations.



MicromP Series

Cost-efficient, configurable power supply with market-leading density and efficiency

Up to 1800 Watts with New Product Enhancements

NEW!

Total Power: Up to 1800 Watts
 Input Voltage: 85-264 Vac
 120-300 Vdc
 # of Outputs: Up to 12



Special Features

- Optional conformal coating
- Industrial temp range (-40 °C to 70 °C)
- Industrial shock/vibration (> 50 G's)
- Low cost
- Standard medical leakage (< 400 µA) with Optional low leakage (< 100 µA)
- New 1000W modules
- PMBus
- High efficiency
- Low profile 1U size
- Multi output
- Current limit - constant current foldback (optional)
- High power density
 - uMP04: 10.8 W/cu-in
 - uMP09: 18.0 W/cu-in
 - uMP10: 15.1 W/cu-in
 - uMP16: 22.9 W/cu-in
- Intelligent fan (speed control/fault status)
- Low Acoustic Noise
- Downloadable GUI from website
- µP controlled PFC input with active inrush protection
- No preload required
- IEC, Terminal Block, or Barrier Strip input option

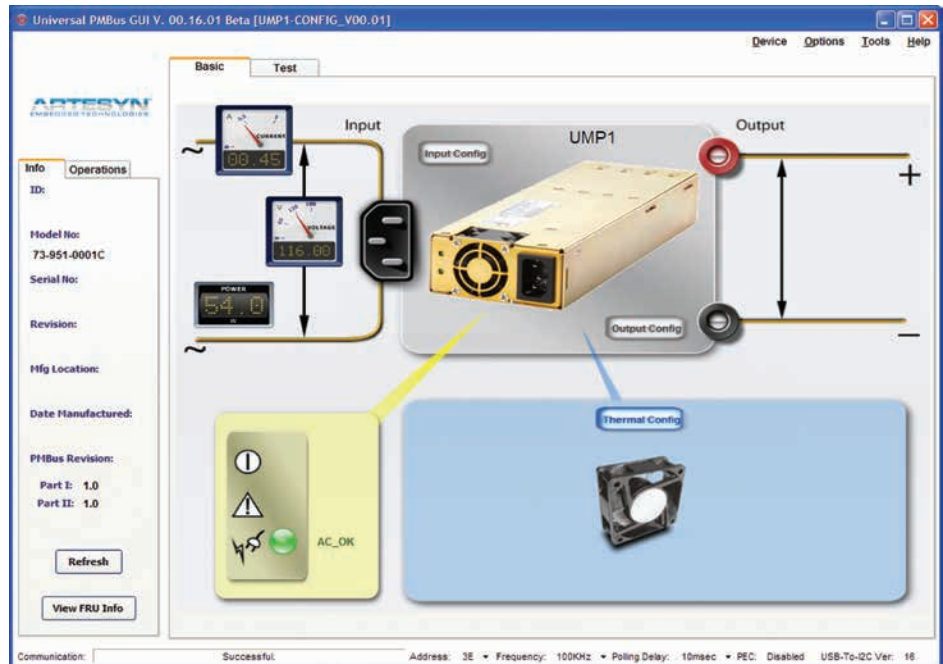

Electrical Specifications

Input	
Input range	85-264 Vac 120-350 Vdc (limited to 300 Vdc in medical apps)
Frequency	47-440 Hz
Inrush current	40 A peak max. (soft start)
Efficiency	Up to 91% @ full case load
Power factor	0.99 typ. meets EN61000-3-2 (n/a @ 440 Hz)
Turn-on time	AC on 2 sec for µMP10/16 and 1.5 sec for µMP04, inhibit/enable 250 ms typical
EMI filter	CISPR 22/EN55022 Level "B"
Leakage current	< 200 µA using center-tapped xfmr measurement method. (< 400 µA @ 264 VAC input)
Radiated EMI	CISPR 22/EN55022 Level "B"
Warranty	Two years

Electrical Specifications

Output	
Factory set point accuracy	±1%
Margining or Optional V Program	±3-7% nominal analog (single output module only)
Overall regulation	0.4% or 30 mV which ever is greater
Ripple	RMS: 0.1% or 10 mV, whichever is greater Pk-Pk: 1.0% or 50 mV, whichever is greater Bandwidth limited to 20 MHz
Dynamic response	< ±5% or 250 mV, with 50% step load
Recovery time	To within 1% in < 300 µs
Reverse voltage protection	100% of rated output current
Thermal protection (OTP)	All outputs disabled when internal temp exceeds safe operating range.
Remote sense	Up to 0.5 V total drop (not available on triple output module)
Single wire parallel	Current share to within 5% of total rated current
DC OK	±5% of nominal
Minimum load	Not required; signal is open collector
Housekeeping standby	5 Vdc @ 2.0 A max. present whenever AC input is applied
Module inhibit	Logic - output on with low or open. Different logic options available
Output/Output isolation	> 1 Megohm, 500 V

Voltage Codes

NEW!

Module Output Voltage Code	Single Output One Slot 240 Watts Max	Single Output Three Slots 1000 Watts Max	Dual Output One Slot 96 Watts		
Module Identification	S2	SK	I		
Code	Volts	Output Current V1	Output Current V1	Output Current V1	Output Current V2
A	2.0	40.0	-	NA	
B	2.2	40.0	-	NA	
C	3.0	40.0	-	NA	
D	3.3	40.0	-	4.0	4.0
E	5.0	36.0	-	4.0	4.0
F	5.2	34.0	-	4.0	4.0
G	5.5	32.0	-	4.0	4.0
H	6.0	30.0	84.0	4.0	4.0
I	8.0	25.0	84.0	4.0	4.0
J	10.0	24.0	84.0	4.0	4.0
K	11.0	22.0	84.0	4.0	4.0
L	12.0	20.0	84.0	4.0	4.0
M	14.0	17.0	71.4	4.0	4.0
N	15.0	16.0	66.7	4.0	4.0
O	18.0	13.0	42.0	4.0	4.0
P	20.0	12.0	42.0	4.0	4.0
Q	24.0	10.0	42.0	4.0	4.0
R	28.0	8.6	35.7	3.4	3.4
S	30.0	8.0	33.3	3.4	3.4
T	33.0	7.0	21.0	NA	
U	36.0	6.7	21.0	NA	
V	42.0	5.7	21.0	NA	
W	48.0	5.0	21.0	NA	
X	54.0	4.4	18.5	NA	
Y	60.0	4.0	16.7	NA	

Environmental Specifications

Operating temperature	-40 °C to 70 °C ambient. Derate each output 2.5% per degree from 50 °C to 70 °C. (-20 °C start up) Meets full spec after 1/2 load. 10 min warm-up
Storage temp	-40 °C to 85 °C
Electromagnetic susceptibility	Designed to meet EN61000-4; -3, -6, -11 Level 3, Level 4 for -2, -4, -5
Humidity	Operating; non-condensing 10% to 95% RH
Vibration	MIL-STD-810E
MTBF demonstrated	> 350,000 hours at full load, one µMP04 case + two modules, Telcordia SR-332 calculated MTBF
Altitude:	Up to 10k feet; derate linear to 50% from 10k-30k feet

Safety

UL	UL60950/UL60601-1
CSA	CSA22.2 No. 234 Level 5
VDE	EN60950/EN60601-1
BABT	Compliance to EN60950/EN60601 BS7002
CB	Certificate and report
CE	Mark to LVD
CCC	Approved

Parallel Codes

Code	Slots in Parallel	Code	Slots in Parallel	Code	Slots in Parallel
1	1&2	6	1&2&3	B	1,2&3; 4&5
2	2&3	7	1,2,3&4	C	1,2,3&4; 5&6
3	3&4	8	1,2,3,4&5	D	1&2; 3&4; 5&6
4	4&5	9	1,2,3,4,5&6	E	1,2&3; 4,5&6
5	5&6	A	1&2; 3&4	O	no module in parallel
				H	3,4&5
				J	3,4,5&6
				K	4,5&6

Ordering Information

Case Size	Module/Voltage	Case Option Codes	Software Code	Hardware Code
µMPXY	SKW - S2E - S2Q - ILL	00	A	###
1-Phase Input where X = 04 = 1.57" x 3.5" x 10.0"; 400 W - 600 W, 4 Slots 09 = 1.57" x 3.5" x 10.0", 550 W - 1100 W, 4 Slots 10 = 1.57" x 5.0" x 10.0", 1000 W - 1200 W, 6 Slots 16 = 1.57" x 5.0" x 10.0", 1200 W - 1800 W**, 6 Slots ** See Input Derating table below for uMP16 Input Type where Y = T = Terminal Block C = IEC Connector C14 S = Barrier Strip	Module Codes S2 = 200 W Single O/P (1 Slot) SK = 1000 W Single O/P (3 Slot) I = 96 W Dual O/P ISO GND (1 Slot) Voltage Codes: See Voltage Code Table	Case Option Codes First digit 0 - K = Parallel Code Second digit 0 = No Options 1 = Reverse Air 2 = Not Used 3 = Global Enable 5 = Opt 1 + Opt 3	Factory assigned for modified standards	Factory assigned for modified standards

Intelligent MP Series

Intelligent modular power supply for optimum flexibility

Up to 1500 Watts

Total Power: Up to 1500 Watts
 Input Voltage: 85-264 Vac
 120-300 Vdc
 # of Outputs: Up to 21



iMP™

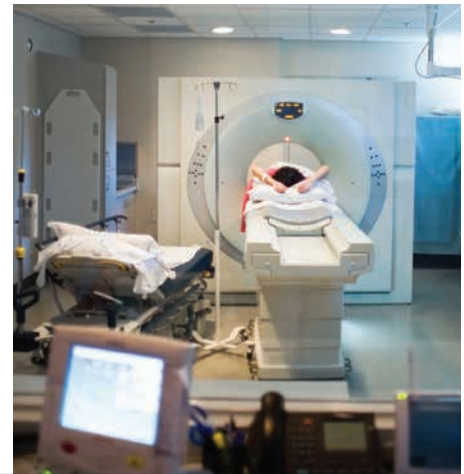

Special Features

- Medical EN60601-1 approval
- Intelligent I²C control
- Voltage adjustment on all outputs (Manual or I²C)
- Configurable input and output (case and module) OK signals and indicators
- Configurable inhibit/enable
- Configurable output UP/DOWN sequencing
- Configurable current limit (foldback or constant current)
- High power density (8.8 W/cu-in)
- Intelligent fan (speed control/fault status)
- Downloadable GUI from website
- Customer provided air option
- μ P controlled PFC input with active inrush protection
- I²C monitor of voltage, current and temp
- Programmable voltage, current limit, inhibit/enable through I²C
- Optional extended hold-up module (SEMI F47 compliance)
- CAN BUS and RS-485 interface option
- Low leakage (< 300 μ A)
- Increased power density to 50% over standard MP
- Backward compatibility with standard MP
- External switching frequency sync input
- Optional conformal coating
- Industrial temp range (-40 °C to 70 °C)
- No preload required
- Industrial shock/vibration (> 50 G's)



Electrical Specifications

Input	
Input range	85-264 Vac 120-350 Vdc (limited to 300 Vdc in medical applications)
Frequency	47-440 Hz
Inrush current	40 A peak max. (soft start)
Efficiency	Up to 85% @ full case load
Power factor	0.99 typ. meets EN61000-3-2 (n/a @ 440 Hz)
Turn-on time	AC on 2 sec typ., inhibit/enable 150 ms typical Programmable delay; 50 ms internal turn-on delay (Dual Output only)
EMI filter	CISPR 22/EN55022 Level "B"
Leakage current	300 μ A max. @ 240 Vac; 47-63 Hz
Radiated EMI	CISPR 22/EN55022 Level "B"
Holdover storage	20 ms minimum (independent of input Vac) additional 34 ms holdover storage with optional HUP module (SEMI F47 compatible)
AC OK	> 5 ms early warning min. before outputs lose regulation Full cycle ride thru (50 Hz) (N/A on iMP4 > 750 W @ 90 Vac)
Harmonic distortion	Meets EN61000-3-2
Isolation	Meets EN60950 and EN60601
Global Inhibit/Enable	TTL, Logic "1" and Logic "0"; configurable
Input fuse (internal)	iMP4: 16 A; iMP8: 20 A; iMP1: 25 A (both lines fused)
Warranty	Three years

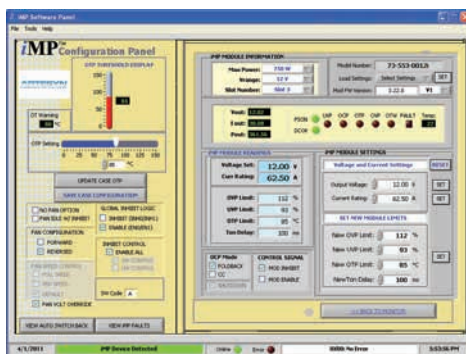

The iMP software is designed to make the iMP Power Supply Unit (PSU) accessible to the user. It is intended to provide information gathered from the PSU and interactive controls to the basic capabilities of iMP power supply. To download go to: www.artesyn.com/impsoftware

Output	
Adjustment range*	±10% minimum all outputs (manual) (full module adjustment range using I ² C)
Margining	±4-6% nominal analog (single output module only)
Overall regulation	0.4% or 20 mV max. (1500 W modules 1% max. 36 W modules 4% max.)
Ripple	RMS: 0.1% or 10 mV, whichever is greater Pk-Pk: 1.0% or 50 mV, whichever is greater Bandwidth limited to 20 MHz
Dynamic response	< 2% or 100 mV, with 25% load step
Recovery time	To within 1% in < 300 µs
Overcurrent protection**	Configurable through I ² C (calibration required). Single output module and main output of the dual output module 105-120% of rated output current. Aux output of dual output module 105-140% of rated output current
Short-circuit protection	Protected for continuous short-circuit Recovery is automatic upon removal of short
Overvoltage protection*	Configurable through I ² C - Single output module 2-5.5 V 122-134%; 6-60 V 110-120% - Dual output module 2-6 V 122-134%; 8-28 V 110-120% - Triple output module
Reverse voltage protection	100% of rated output current
Thermal protection* (OTP and OTW)	Configurable through I ² C All outputs disabled when internal temp exceeds safe operating range. > 5 ms warning (AC OK signal) before shutdown
Remote sense	Up to 0.5 V total drop (not available on triple output module)
Single wire parallel	Current share to within 2% of total rated current
DC OK*	±5% of nominal. Configurable through I ² C
Minimum load	Not required
Housekeeping standby	5 Vdc @ 1.0 A max. present whenever AC input is applied (Optional 2.0 A available)
Module inhibit*	Configured and controlled through I ² C
Switching frequency	250 kHz accepts external sync signal
Output/Output isolation	> 1 Megohm, 500 V

* Can be controlled via I²C
** Controlled via I²C but requires load calibration

Environmental Specifications

Operating temperature	-40 °C to 70 °C ambient. Derate each output 2.5% per degree from 50 °C to 70 °C. (-20 °C start up)
Storage temperature	-40 °C to 85 °C
Electromagnetic susceptibility	Designed to meet EN61000-4; -2, -3, -4, -5, -6, -8, -11 Level 3
Humidity	Operating; non-condensing 10% to 95% RH
Vibration	IEC68-2-6 to the levels of IEC721-3-2
MTBF demonstrated	> 550,000 hours at full load, 220 Vac and 25 °C ambient conditions

Safety

UL	UL60950/UL2601
CSA	CSA22.2 No. 234 Level 5
VDE	EN60950/EN60601-1
BABT	Compliance to EN60950/ EN60601 BS7002
CB	Certificate and report
CE	Mark to LVD

Output Module Line-up

Module Code	1	2	3	5	4	
Module Type	Single	Single	Single	Single	Dual	Triple
Max output power	210 W	360 W	750 W	1500 W	144 W	36 W
Max output current	35 A	60 A	150 A	300 A	10 A	2 A
Output voltages available*	2-60 V	2-60 V	2-60 V	2-60 V	6-15, 24-28; 6-15; 6-15; 6-15; 2-6; 2-6, 2-6; 24-28, 24-28; 24-28; 2-6	8-15, 8-15, 2-6; 8-15, 8-15, 8-15; 8-15, 8-15, 18-28; 8-15, 18-28, 2-6
Standard voltage increments	25	25	25	18	16	18
Remote sense	Yes	Yes	Yes	Yes	Yes	No
Remote margin*	Yes	Yes	Yes	Yes	No	No
V-Program - I ² C Control*	Yes	Yes	Yes	Yes	Yes	No
Active Current Share	Yes	Yes	Yes	Yes	Yes	No
Module Inhibit - I ² C Control*	Yes	Yes	Yes	Yes	Yes	Yes
Module Inhibit - Analog	Yes	Yes	Yes	Yes	No	No
Overvoltage/Overcurrent protection*	Yes	Yes	Yes	Yes	Yes	Yes
Minimum load required	No	No	No	No	No	No
Slots occupied in any iMP case	1	2	3	4	1	1

* Programmable

Output Module Voltage/Current

Voltage	Voltage Code	Single Output Module Code				Dual Output**		Triple Output			I ² C Adjustment Ranges***
		1	2	3	5+	V1	V2	-	-	-	
2 V	A	35 A	60 A	150 A	300 A	10 A	10 A	-	-	2 A	1.8-2.2
2.2 V	B	35 A	60 A	150 A	300 A	10 A	10 A	-	-	2 A	2.0-2.4
3 V	C	35 A	60 A	150 A	300 A	10 A	10 A	-	-	2 A	2.7-3.3
3.3 V	D	35 A	60 A	150 A	300 A	10 A	10 A	-	-	2 A	3.0-3.6
5 V	E	35 A	60 A	150 A	300 A	10 A	10 A	-	-	2 A	4.5-5.5
5.2 V	F	35 A	60 A	144 A	288 A	10 A	10 A	-	-	2 A	4.7-5.7
5.5 V	G	34 A	58 A	136 A	273 A	10 A	10 A	-	-	2 A	5.0-6.1
6 V	H	23 A	42 A	97.5 A	250 A	10 A*	10 A*	-	-	2 A	5.4-6.6
8 V	I	20 A	36 A	84.4 A	140 A	10 A	4 A	1 A	1 A	1 A	7.2-8.8
10 V	J	18 A	32 A	75 A	140 A	10 A	4 A	1 A	1 A	1 A	9.0-11.0
11 V	K	17 A	31 A	68 A	136.3 A	10 A	4 A	1 A	1 A	1 A	9.9-12.1
12 V	L	17 A	30 A	62.5 A	125 A	10 A	4 A	1 A	1 A	1 A	10.8-13.2
14 V	M	14 A	21 A	53.5 A	107 A	9 A	4 A	1 A	1 A	1 A	12.6-15.4
15 V	N	14 A	20 A	50 A	100 A	8 A	4 A	1 A	1 A	1 A	13.5-16.5
18 V	O	11 A	19 A	41.6 A	83.3 A	-	-	-	0.5 A	0.5 A	16.2-19.8
20 V	P	10.5 A	18 A	37.5 A	75 A	-	-	-	0.5 A	0.5 A	18.0-22.0
24 V	Q	8.5 A	15 A	30 A	62.5 A	4 A	2 A	-	0.5 A	0.5 A	21.6-26.4
28 V	R	6.7 A	11 A	26.8 A	53.5 A	3 A	2 A	-	0.5 A	0.5 A	25.2-30.8
30 V	S	6.5 A	11 A	25 A	50 A	-	-	-	-	-	27.0-33.0
33 V	T	6.2 A	10.9 A	22.7 A	35.8 A	-	-	-	-	-	29.7-36.3
36 V	U	5.8 A	10 A	20.8 A	35.8 A	-	-	-	-	-	32.4-39.6
42 V	V	4.2 A	7.5 A	16 A	35.7 A	-	-	-	-	-	37.8-46.2
48 V	W	4 A	7.5 A	15.6 A	31.2 A	-	-	-	-	-	43.2-52.8
54 V	X	3.7 A	6 A	13.9 A	27.7 A	-	-	-	-	-	48.6-59.4
60 V	Y	3.5 A	6 A	12.5 A	25 A	-	-	-	-	-	54.0-66.0
Consult Factory											
Special	Z	35 A	60 A	150 A	-	-	10 A	-	-	-	2.3-2.6
Special	Z	35 A	60 A	150 A	-	-	10 A	-	-	-	3.7-4.4
Special	Z	20 A	36 A	80 A	140 A	-	8 A	-	-	-	6.7-7.1

* Note: Contact factory for extended range down to 6 V.
 ** Total output power on dual module must not exceed 144 W.
 *** For single output modules only.
 + Applicable for iMP1 only.

Parallel Codes

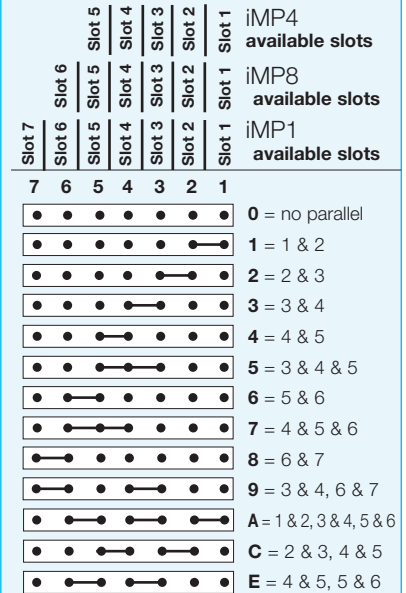

Increments of current not shown can be achieved by paralleling modules (add currents of each module selected).

Ordering Information

Sample below is 1500 W case with 12 V @ 62.5 A; 5 V @ 60 A; 24 V @ 8.5 A; 12 V @ 10 A; 12 V @ 4 A; with no options.

Case Size	Module/Voltage/Option Codes	Case Option Codes	Software Code	Hardware Code
iMP1*	3L0 - 2E2 - 1Q1 - 4LL0	00	A	###
<p>Case Size (mm) 4 = 2.5" x 5" x 10"; 750-1100 W, 5 slots (63.5 x 127 x 254) 8 = 2.5" x 7" x 10"; 1000-1200 W, 6 slots (63.5 x 177.8 x 254) 1 = 2.5" x 8" x 11"; 1200-1500 W, 7 slots (63.5 x 203.2 x 279.4)</p> <p>*Note: Add "E" after iMP4 to denote IEC input option. e.g., iMP4E (Not available on iMP8 or iMP1)</p>	<p>Module Codes Module/voltage/option codes Module codes: (None) = 36 W triple O/P (1 slot) 1 = 210 W single O/P (1 slot) 2 = 360 W single O/P (2 slot) 3 = 750 W single O/P (3 slot) 4 = 144 W dual O/P (1 slot) 5 = 1500 W single O/P (4 slot) 6 - 9 = Future</p> <p>Voltage Codes: See Output Module Voltage/Current table above</p> <p>Option Codes: 0 = Standard 1 = Module enable 2 = Constant current 3 = 1 & 2 combined 4 = Set for use in standard (non-intelligent case) 5 = Shutdown mode for 1500 W 6 = 1 & 5 combined 7 - 9 = Future</p>	<p>Case Option Codes First digit 0 - 9 = parallel code (See Parallel Codes table above)</p> <p>Second digit 0 = No options 1 = Reverse air 3 = Global enable 4 = Fan idle w/inhibit 5 = Opt 1 + Opt 3 6 = Opt 1 + Opt 4 7 = Opt 3 + Opt 4 8 = Opt 1 + 3 + 4 9 = RS-485 73-544-002 C = 9 + 3 D = CANBUS 73-544-003 E = D + 3</p>	<p>Software code used for configuration change. "A" is standard</p>	<p>Factory assembled for hardware of firmware mods.</p>
<p>Ordering Note: 1. USB to I²C module order code 73-769-001 or -002</p>				

Intelligent VS Series

Intelligent modular power supply for optimum flexibility

Up to 4920 Watts

Total Power: Up to 4920 Watts
 Input Voltage: 85-264 Vac
 120-300 Vdc
 # of Outputs: Up to 24

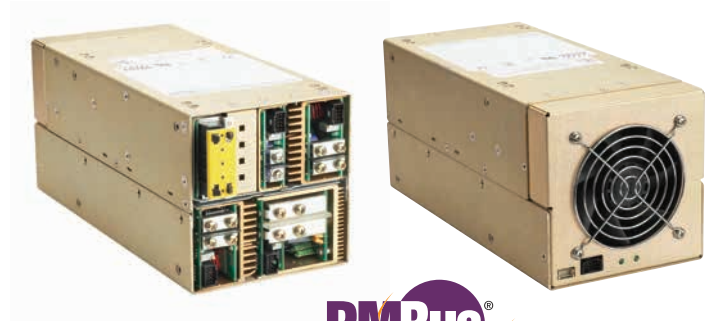

Special Features

- **Medical EN60601-1 approval**
- Intelligent I²C control
- Voltage adjustment on all outputs (manual or I²C)
- Configurable input and output OK signals and indicators
- Configurable inhibit/enable
- Configurable output UP/DOWN sequencing
- High power density (12 W/cu-in)
- Intelligent fan (speed control/fault status)
- μ P controlled PFC input with active Inrush protection
- I²C monitor of voltage, current and temp
- Programmable voltage, current limit, inhibit/enable through I²C
- CAN BUS and RS-485 interface option
- Optional extended hold-up module (SEMI F47 compliance)
- Increased power density to 150%
- Optional conformal coating
- Industrial temp range (-40 °C to 70 °C)
- Uses standard iMP modules
- Field upgradeable firmware
- RoHS compliant

Single



210 W



750 W



360 W



1500 W (2.0 - 8.0 V)

Dual



144 W



1500 W (10 - 60 V)

Triple



36 W



1500 W with Bus Bar Adaptor Option (used with the 10 - 60 V module)

Electrical Specifications

Input	
<i>Input range</i>	
iVS1 & iVS3:	90-264 Vac 1 \emptyset : 120-300 Vdc
iVS6 & iVS8:	170-264 Vac 3 \emptyset
iVS8H:	380/480 Vac 3 \emptyset
Frequency	47-440 Hz
Inrush current	40 A peak maximum (soft start)
Efficiency	Up to 85% @ full case load
Power factor	0.99 typ. meets EN61000-3-2
Turn-on time	AC on 1.5 sec typical, inhibit/enable 150 ms typical. Programmable
EMI Filter	CISPR 22/EN55022 Level "B"
Leakage current	300 μ A max. @ 240 Vac; 47-63 Hz
Radiated EMI	CISPR 22/EN55022 Level "B"
Holdover storage	10 ms minimum (independent of input Vac) additional 20 ms holdover storage with optional HUP module (SEMI F47 compatible)
AC OK	> 5 ms early warning minutes before outputs lose regulation. Full cycle ride thru (50 Hz). Programmable
Harmonic distortion	Meets EN61000-3-2
Isolation	Meets EN60950 and EN60601
Global inhibit/enable	TTL, Logic "1" and Logic "0"/configurable
Warranty	Three years

Output	
Adjustment range*	±10% minimum all outputs (manual) (full module adjustment range using I ² C)
Margining	±4-6% nominal analog (single output module only)
Overall regulation	0.4% or 20 mV max. (1500 W modules 1% max.)
Ripple	RMS: 0.1% or 10 mV, whichever is greater Pk-Pk: 1.0% or 50 mV, whichever is greater Bandwidth limited to 20 MHz
Dynamic response	< 2% or 100 mV, with 25% load step
Recovery time	To within 1% in < 300 µs
Overcurrent protection**	Configurable through I ² C. single output module and main output of the dual output module 105-120% of rated output current. Aux output of dual output module 105-140% of rated output current. Special programmable OCP delay on 1500 W module from 100 ms to 25.5 seconds with shutdown features
Short-circuit protection	Protected for continuous short-circuit Recovery is automatic upon removal of short (Shutdown mode on 1500 W module)
Overvoltage protection*	Configurable through I ² C – Single output module 2-5.5 V 122-134%; 6-60 V 110-120% – Dual output module 2-6 V 122-134%; 8-28 V 110-120% – Triple output module No overvoltage protection provided
Thermal protection*	Configurable through I ² C All outputs disabled when internal temp exceeds safe operating range. > 5 ms warning (AC OK signal) before shutdown
Remote sense	Up to 0.5 V total drop (not available on triple output module)
Single wire parallel	Current share to within 2% of total rated current
DC OK*	±5% of nominal. Configurable through I ² C
Minimum load	Not required
Housekeeping bias voltage	5 Vdc @ 1.0 A max. present whenever AC input is applied
Module inhibit*	Configured and controlled through I ² C
Output/Output isolation	> 1 Megohm, 500 V

* Can be controlled via I²C

** Controlled via I²C but requires load calibration

Environmental Specifications

Operating temperature	-40 °C to 70 °C ambient. Derate each output 2.5% per degree from 50 °C to 70 °C. (-20 °C start up)
Storage temperature	-40 °C to 85 °C
Electromagnetic susceptibility	Designed to meet EN61000-4; -2, -3, -4, -5, -6, -8, -11 Level 3
Humidity	Operating; non-condensing 10% to 95% RH
Vibration	IEC68-2-6 to the levels of IEC721-3-2
MTBF demonstrated	> 550,000 hours at full load, 220 Vac and 25 °C ambient conditions

Safety

UL	UL60950/UL2601
CSA	CSA22.2 No. 234 Level 5
VDE	EN60950/EN60601-1
BABT	Compliance to EN60950/ EN60601 BS7002
CB	Certificate and report
CE	Mark to LVD

Output Module Line-up

Module Code	1	2	3	5	4	
Module Type	Single	Single	Single	Single	Dual	Triple
Max output power	210 W	360 W	750 W	1500 W	144 W	36 W
Max output current	35 A	60 A	150 A	300 A	10 A	2 A
Output voltages available*	2-60 V	2-60 V	2-60 V	2-60 V	6-15, 24-28; 6-15; 6-15; 6-15; 2-6; 2-6, 2-6; 24-28, 24-28; 24-28; 2-6	8-15, 8-15, 2-6; 8-15, 8-15, 8-15; 8-15, 8-15, 18-28; 8-15, 18-28, 2-6
Standard voltage increments	25	25	25	18	16	18
Remote sense	Yes	Yes	Yes	Yes	Yes	Yes
Remote margin*	Yes	Yes	Yes	Yes	No	No
V-Program - I ² C Control*	Yes	Yes	Yes	Yes	Yes	Yes
Active Current Share	Yes	Yes	Yes	Yes	Yes	No
Module Inhibit - I ² C Control*	Yes	Yes	Yes	Yes	Yes	Yes
Module Inhibit - Analog	Yes	Yes	Yes	Yes	No	No
Overvoltage/Overcurrent protection*	Yes	Yes	Yes	Yes	Yes	Yes
Minimum load required	No	No	No	No	No	No
Slots occupied in any iMP case	1	2	3	4	1	1

* Programmable



Output Module Voltage/Current

Voltage	Voltage Code	Single Output Module Code				Dual Output**		Triple Output			I ² C Adjustment Ranges***
		1	2	3	5	V1	V2				
2 V	A	35 A	60 A	150 A	300 A	10 A	10 A	—	—	2 A	1.8-2.2
2.2 V	B	35 A	60 A	150 A	300 A	10 A	10 A	—	—	2 A	2.0-2.4
3 V	C	35 A	60 A	150 A	300 A	10 A	10 A	—	—	2 A	2.7-3.3
3.3 V	D	35 A	60 A	150 A	300 A	10 A	10 A	—	—	2 A	3.0-3.6
5 V	E	35 A	60 A	150 A	300 A	10 A	10 A	—	—	2 A	4.5-5.5
5.2 V	F	35 A	60 A	144 A	288 A	10 A	10 A	—	—	2 A	4.7-5.7
5.5 V	G	34 A	58 A	136 A	273 A	10 A	10 A	—	—	2 A	5.0-6.1
6 V	H	23 A	42 A	97.5 A	250 A	10 A*	10 A*	—	—	2 A	5.4-6.6
8 V	I	20 A	36 A	84.4 A	140 A	10 A	4 A	1 A	1 A	1 A	7.2-8.8
10 V	J	18 A	32 A	75 A	140 A	10 A	4 A	1 A	1 A	1 A	9.0-11.0
11 V	K	17 A	31 A	68 A	136.3 A	10 A	4 A	1 A	1 A	1 A	9.9-12.1
12 V	L	17 A	30 A	62.5 A	125 A	10 A	4 A	1 A	1 A	1 A	10.8-13.2
14 V	M	14 A	21 A	53.5 A	107 A	9 A	4 A	1 A	1 A	1 A	12.6-15.4
15 V	N	14 A	20 A	50 A	100 A	8 A	4 A	1 A	1 A	1 A	13.5-16.5
18 V	O	11 A	19 A	41.6 A	83.3 A	—	—	—	0.5 A	0.5 A	16.2-19.8
20 V	P	10.5 A	18 A	37.5 A	75 A	—	—	—	0.5 A	0.5 A	18.0-22.0
24 V	Q	8.5 A	15 A	30 A	62.5 A	4 A	2 A	—	0.5 A	0.5 A	21.6-26.4
28 V	R	6.7 A	11 A	26.8 A	53.5 A	3 A	2 A	—	0.5 A	0.5 A	25.2-30.8
30 V	S	6.5 A	11 A	25 A	50 A	—	—	—	—	—	27.0-33.0
33 V	T	6.2 A	10.9 A	22.7 A	35.8 A	—	—	—	—	—	29.7-36.3
36 V	U	5.8 A	10 A	20.8 A	35.8 A	—	—	—	—	—	32.4-39.6
42 V	V	4.2 A	7.5 A	16 A	35.7 A	—	—	—	—	—	37.8-46.2
48 V	W	4 A	7.5 A	15.6 A	31.2 A	—	—	—	—	—	43.2-52.8
54 V	X	3.7 A	6 A	13.9 A	27.7 A	—	—	—	—	—	48.6-59.4
60 V	Y	3.5 A	6 A	12.5 A	25 A	—	—	—	—	—	54.0-66.0
Consult Factory											
Special	Z	35 A	60 A	150 A	—	—	10 A	—	—	—	2.3-2.6
Special	Z	35 A	60 A	150 A	—	—	10 A	—	—	—	3.7-4.4
Special	Z	20 A	36 A	80 A	140 A	—	8 A	—	—	—	6.7-7.1

* Note: Consult factory for extended range down to 6 V.

** Total output power on dual model must not exceed 144 W.

*** For single output modules only.

Ordering Information

Sample below is 3210 W case with 12 V @ 125 A; 24 V @ 8.5 A; 5 V @ 60 A; 12 V @ 10 A and 12 V @ 4 A; with no options.

Case Size	Module/Voltage/Option Codes	Case Option Codes	Software Code	Hardware Code
iVS1	5L1 - 1Q1 - 2E0 - 4LLO	00	A	###
<p>Case Size (mm)</p> <p>1-Phase Input</p> <p>1 = 5" x 5" x 11"; 1500-3210 W, 9 slots (127 x 127 x 279.4)</p> <p>3 = 5" x 8" x 11"; 1800-4920 W, 14 slots (127 x 203.2 x 279.4)</p> <p>3-Phase Input</p> <p>6 = 5" x 5" x 11"; 3120 W, 9 slots (127 x 127 x 279.4)</p> <p>8 = 5" x 8" x 11"; 4920 W, 14 slots (127 x 203.2 x 279.4)</p> <p>8H* = 5" x 8" x 11"; 4920 W, 14 slots (127 x 203.2 x 279.4)</p> <p>* Note: The input is 380-440 Vac 3 phase nominal, 3-phase versions not medically approved.</p>	<p>Module Codes</p> <p>Module/voltage/option codes</p> <p>Module Codes:</p> <p>(None) = 36 W triple O/P (1 slot)</p> <p>1 = 210 W single O/P (1 slot)</p> <p>2 = 360 W single O/P (2 slot)</p> <p>3 = 750 W single O/P (3 slot)</p> <p>5 = 1500 W single O/P (slot 4)</p> <p>4 = 144 W dual O/P (1 slot)</p> <p>HUP = Extra 30mS hold-up (1 slot)</p> <p>Voltage Codes:</p> <p>See Output Module Voltage/Current table above</p> <p>Option Codes:</p> <p>0 = Standard</p> <p>1 = Module enable</p> <p>2 = Constant current</p> <p>3 = 1 & 2 combined</p> <p>4 = Set for use in standard (non-intelligent case)</p> <p>5 = Shutdown mode for 1500 W</p> <p>6 = 1 & 5 combined</p> <p>7-9 = Future</p>	<p>Case Option Codes</p> <p>First Digit</p> <p>0-9 = Parallel code (See parallel codes table in datasheet)</p> <p>Second Digit</p> <p>0 = No options</p> <p>1 = Reverse air</p> <p>2 = Not used</p> <p>3 = Global enable</p> <p>4 = Fan idle w/inhibit</p> <p>5 = Opt 1 + Opt 3</p> <p>6 = Opt 1 + Opt 4</p> <p>7 = Opt 3 + Opt 4</p> <p>8 = Opt 1 + 3 + 4</p> <p>9 = RS485 73-544-001</p> <p>B = USB 73-546-001</p> <p>C = 9 + 3</p> <p>D = CANBus 73-544-004</p> <p>E = D + 3</p>	<p>Software code used for configuration change. "A" is standard</p>	<p>Factory assembled for hardware of firmware mods.</p>
<p>Ordering Note:</p> <p>1. USB to I²C module order code 73-769-001</p>				

Precision High Power System

Up to 24000 Watts

Total Power: Up to 24 KW
 Input Voltage: 180-264 Vac
 342-528 Vac
 3-Phase
 1-Phase available on 12KW Modules
 # of Outputs: Up to 8

NEW!

iHP



Special Features

- Multi output precision high power system
- Standard 19" rack
- Outputs parallel up to 1600 A
- Outputs series up to 1000 V
- 100% digital control
- Outputs program as voltage or current source
- Versatile input configurable to:
 - Low Line 180-264 Vac Single/3-Phase
 - High Line 342-528 Vac 3-Phase
- Medical safety approved – NO ISOLATION XFMR NEEDED
- Flexible control interfaces: Analog 0-5 V or 0-10 V; Digital Ethernet UDP, RS485, CAN, etc. or Ethernet TC/IP with PowerPro Connect Module option. Command protocol standard PMBus.
- Air cooled
- Semi F47 compliance
- Field upgradeable firmware
- Programmable slew rate
- Fast current slew rate up to 200 Hz
- Active power factor correction
- User defined command profiles
- Direct drive current source for large scale LED grow luminaries

Electrical Specifications

Input Parameter	19" Rack 24 KW strapped as 3-Phase 380/480 Vac Nominal (iHP24H3A/L)	19" Rack 24 KW strapped as 3-Phase 208/240 Vac Nominal (iHP24L3A/L)
Input range	342 Vac to 528 Vac (Nominal rating 380/480 Vac)	187.5 Vac to 264 Vac (Nominal rating 208/240 Vac)
Number of phases	3-phase (Wye or Delta) 4 wire total (3-phase and 1 protective earth ground)	
Frequency	47-440 Hz	
Phase detection	Loss of phase will inhibit unit off. Housekeeping/comms must continue with phase loss.	
Max current/phase	51 A @ 380 Vac 40 A @ 480 Vac	84 A @ 208 Vac
Undervoltage detection	Nominal input locked on at turn-on. Undervoltage shutdown at 15% below nominal. Turn-on at 12% below nominal. Not to interfere with SEMI F47 specs.	
Current inrush	2.5 x Max input current	
Power factor	> 0.9 @ full load and nominal line	> 0.98 @ full load and nominal line
Harmonic distortion	THD < 13%, PWhd < 22% (refer to EN 61000-3-12)	
Line interruption	Designed to meet SEMI F47-0706, 53, 58, S14 at nominal input voltages	
Input leakage current	< 2.5 mA Note for fixed condition 3rd edition leakage = 5 mA	
POWER switch	Front panel power switch required	
Input protection	Internal fuse (not user serviceable)	
Input overvoltage protection	Up to 115% of nominal input shall not damage unit	
Phase imbalance	≤ 5%	
Rack parallel	Up to 6 racks (144 KW)	

Safety

UL 60950-1 2 nd Edition; EN60950-1; IEC60950-1/EN60950
CSA C22.2 No. 60950-1-07, 2 nd Edition
EN60601-1; IEC60601-1; IEC60601
UL 60601-1 1st Edition; ANSI/AAMI ES60601-1 (2005 + C1:09 + A2:10) "3 rd Ed"
CAN/CSA-C22.2 No. 60601-1 (2008)
UL/CSA 61010 and IEC/EN 61010-1
CB Certificate and Report
CE (LVD+RoHS), EN60950-1

OUTPUT – General Specs

Parameter							
MODULE CODE	SL	SQ	SW	S8	S1	SA	S2
# Outputs	1	1	1	1	1	1	1
Nominal O/P (V)	12.0 V	24.0 V	48.0 V	80.0 V	125.0 V	200.0 V	250.0 V
Max Power (W)	2400 W	2880 W	3000 W	3000 W	3000 W	3000 W	3000 W
O/P Current Range (A)	0.0 A - 200 A	0.0 A - 120 A	0.0 A - 62.5 A	0.0 A - 37.5 A	0.0 A - 24 A	0.0 A - 15 A	0.0 A - 12 A
Power Density (W/cu-in)	32.5	39.0	40.6	40.6	40.6	39.0	40.6
Efficiency (%)	93.5	93.5	93.5	93.5	93.5	93.5	93.5
Module Input Voltage	400 Vdc						
Module Operating Temp	-0 °C to +65 °C; Baseplate Temp TBD						
Series Operation	250 V modules can be connected in series up to 800 V for Medical and 1000 V above ground with no operation ON/OFF limitations						
Parallel Operation	Up to 8 modules can be paralleled in 1 rack, with up to 6 racks connected in parallel. Single Wire Parallel connection will be provided as part of configuration						

OUTPUT – Module in Constant Voltage Mode

Constant Voltage							
MODULE CODE	SL	SQ	SW	S8	S1	SA	S2
Nominal Output (V)	12	24	48	80	125	200	250
Setting Range (V)	0.6 V - 14.4 V	1.2 V - 28.8 V	2.4 V - 57.6 V	4.0 V - 96.0 V	6.25 V - 150.0 V	10.0 V - 240.0 V	12.5 V - 300.0 V
Low Frequency RMS Ripple (mV)	24	48	96	160	250	400	500
Line Regulation (mV)	12	24	48	80	125	200	250
Load Regulation (mV)	24	48	96	160	250	400	500
P-P Ripple (mV)	60	120	240	400	625	1250	1250
Drift (Temp Stability)	±0.05% of Iout Rated over 8 hours, after 30 minutes warm up, constant Line, Load and Temp						
Temp Coefficient (PPM/°C)	200						
Pgm Accuracy (mV)	Digital: 0.1% of Nominal Output Voltage; Analog: 1.0% of Nominal Output Voltage						
Pgm Resolution (mV)	SL=TBD; SQ=1; SW=2; S8=8; S1=6; S2=21						
Meas Accuracy (mV)	0.2% + 0.2% of Nominal Output Voltage						
Meas Resolution	SL=TBD; SQ=1; SW=2; S8=8; S1=6; S2=21						
Transient Response	Max 5.0% deviation from current set point must recover within 1mS for a 50% step load.						
Current Sense Method	Internal Shunt; External Shunt can be used for higher resolution and accuracy						

OUTPUT – Module in Constant Current Mode

Constant Voltage - Programmable load compensation available for resistive and inductive loads; capacitive load applications; and LED drive applications							
MODULE CODE	SL	SQ	SW	S8	S1	SA	S2
Nominal Output (V)	12	24	48	80	125	200	250
Setting Range (A)	0.0 A - 200 A	0.0 A - 120 A	0.0 A - 62.5 A	0.0 A - 37.5 A	0.0 A - 24 A	0.0 A - 15 A	0.0 A - 12 A
RMS Ripple (mA)	200	120	62.5	37.5	24	500	12
Line Regulation (mA)	200	120	125	93.75	48	200	24
Load Regulation (mA)	800	480	250	150	96	400	48

OUTPUT – Module in Constant Current Mode

Constant Voltage - Programmable load compensation available for resistive and inductive loads; capacitive load applications; and LED drive applications

P-P Ripple (mA)	N/A					
Drift (Temp Stability)	±0.05% of I _{out} Rated over 8 hours, after 30 minutes warm up, constant Line, Load and Temp					
Temp Coefficient (PPM/°C)	SL, SQ = 300 PPM; All other modules are 200 PPM. Temp Coefficient at rack level is [Temp Coefficient (module level)] + [4500 PPM of Iout-max]					
Pgm Accuracy (A)	0.7% digital, 1.3% of rated output max analog					
Pgm Resolution (mA)	79.2	26.4	13.2	10	5.2	2.6
Meas Accuracy	0.7% + 0.7% of Rated Output Max					
Meas Resolution	79.2	26.4	13.2	10	5.2	2.6
Transient Response	0-63% output current change in 7.5 mSec, residual value 1%, settling time 35 mSec					
Current Sense Method	Internal Shunt					

Ordering Information

CASE CODE		MODULE CODES (up to 8 modules)		PARALLEL/SERIES CASE CODE		MOD CODE
iHP**XYA-		XV-		-XX		-XXX
Case Decoder	iHP**XYA	Module Decoder	XV	Case Code Decoder First Digit	Case Code Decoder Second Digit	
** = Case Power		X = Output Type		0 = None	0 = None	
	12 = 12 KW 19" Rack 24 = 24 KW 19" Rack		S = Single	1 = Slot 1&2	P = Parallel	
X = Voltage Range		V = Nominal Voltage		2 = Slot 2&3	S = Series	
	L = Low Range 180-264		L = 12 V	3 = Slot 3&4	1 = Combo 2 P/S	
	H = High Range 342-528		Q = 24 V	4 = Slot 4&5	2 = Combo 2 S/P	
Y = Input Phase			U = 36 V W = 48 V	5 = Slot 5&6	3 = Combo 3 P/P/S	
	1 = Single (12 KW Only) 3 = 3 Phase		8 = 80 V	6 = Slot 6&7	4 = Combo 3 P/S/P	
Z = Cooling			1 = 125 V	7 = Slot 7&8	5 = Combo 3 P/S/S	
	A = Air Cooled		A = 200 V 2 = 250 V	8 = Slot 1,2&3	6 = Combo 3 S/P/P	
A = Accessory Options				9 = Slot 1,2,3&4	7 = Combo 3 S/P/S	
	Blank = Full control			A = Slot 1,2,3,4&5	8 = Combo 3 S/S/P	
				B = Slot 1,2,3,4,5&6	9 = Combo 4 P/P/P/S	
				C = Slot 1,2,3,4,5,6&7	A = Combo 4 P/P/S/P	
				D = Slot 1,2,3,4,5,6,7&8	B = Combo 4 P/P/S/S	
				E = Slot 1&2; 3&4	C = Combo 4 P/S/P/P	
				F = Slot 1&2; 3&4; 5&6	D = Combo 4 P/S/P/S	
				G = Slot 1&2; 3&4; 5&6; 7&8	E = Combo 4 P/S/S/P	
				H = Slot 1,2&3; 4&5	F = Combo 4 P/S/S/S	
				J = Slot 1,2,&3; 4&5; 6&7	G = Combo 4 S/P/P/P	
				K = Slot 1,2,&3; 4,5&6	H = Combo 4 S/P/P/S	
				L = Slot 1,2,&3; 4,5&6; 7&8	J = Combo 4 S/P/S/P	
				M = Slot 1,2,3&4; 5&6	K = Combo 4 S/P/S/S	
				N = Slot 1,2,3&4; 5&6; 7&8	L = Combo 4 S/S/P/P	
				P = Slot 1,2,3&4; 5,6&7	M = Combo 4 S/S/P/S	
				R = Slot 1,2,3&4; 5,6,7&8	N = Combo 4 S/S/S/P	
				S = Slot 1,2,3,4&5; 6&7		
				T = Slot 1,2,3,4&5; 6,7&8		
				U = Slot 1,2,3,4,5&6; 7&8		

MODEL NUMBER SHORTCUT

For repeated like modules in parallel or series, instead of listing all the same modules separated by a "-", you can simply list the module once and then follow by the number of times it repeats enclosed in parenthesis.

For example:

iHP24H3A-SW-SW-SW-SW-SW-SW-S8-S8-00

would become:

iHP24H3A-SW(6)-S8(2)-00

PowerPro Connect Module



POWERPRO

Part number:73-778-000

The PowerPro Connect Module (purchased separately) can provide standard Ethernet interface via the internet to a cloud- and dashboard-based user-configurable GUI.

LCM300

Bulk front end

300 Watts

Total Power: 300 W (350 W some models)
 # of Outputs: Single
 Output: 12 to 60 V
 Optional 5.0 V standby



Special Features

- 300 W (350 W some models)
- Low Cost
- 1.61" x 4.0" x 7.0"
- 7.1 Watts Per Cubic Inch
- Industrial/Medical Safety
- -40 °C to 70 °C with derating
- Optional 5 V @ 2 A Housekeeping
- High Efficiency: 91% @ 230 VAC
- Variable speed "Smart Fans"
- DSP controlled
- PMBus Compliant
- Conformal coat option
- ±20% adjustment range
- Margin programming (300 W and 600 W models)
- OR-ing FET
- EMI Class B
- EN61000 Immunity
- RoHS 2

Electrical Specifications

Input	
Input range	90 - 264 Vac (Operating) (127-374 Vdc) 115/230 Vac (Nominal) TERMINAL BLOCK
Frequency	47 - 63 Hz, Nominal 50/60
Input fusing	Internal 8 A fuses, both lines fused
Inrush current	≤ 20 A peak, either hot or cold start
Power factor	0.98 typical, meets EN61000-3-2
Harmonics	Meets IEC 1000-3-2 requirements
Input current	5 Arms max input current, at 90 Vac
Hold up time	20 ms minimum for Main O/P, at full rated load
Efficiency	> 91% typical at full Load/230 Vac nominal
Leakage current	< 0.3 mA at 264 Vac
ON/OFF power switch	N/A
Power line transient	MOV directly after the fuse
Isolation	PRI-Chassis 2500 Vdc Basic PRI-SEC 4000 Vac Reinforced 2xMOPP SEC-Chassis 500 Vdc

Environmental Specifications

Operating temperature	-40 °C to +70 °C, linear derating to 50% from 50 °C to 70 °C
Storage temperature	-40 °C to +85 °C
Humidity	20 to 90%, non-condensing. Operating. conformal coat option available
Fan noise	< 45 dBA, 80% load at 40 °C; fan off when unit is inhibited
Altitude	Operating - 16,405 feet (5,000m) Storage - 30,000 feet
Shock	MIL-STD-810F 516.5, Procedure I, VI. storage
Vibration	MIL-STD-810F 514.5, Cat. 4, 10. storage

Safety

UL	60950-1 508/1598/1433 60601-1 Ed 3
CSA	60950-1
VDE	60950-1 60601
China	CCC
CB Scheme	Report/Cert

Electrical Specifications

Output		
Output rating	See ordering information table below	90-264 Vac
Set point	±0.5%	90-264 Vac
Total regulation range	Main output ±2% 5 Vsb ±1%	Combined line/load/transient when measured at output terminal
Rated load	310 W maximum	Derate linear to 50% from 50 °C to 70 °C
Minimum load	Main output @ 0.0 A 5 Vsb @ 0.0 A	No loss of regulation
Output noise (PARD)	1% max p-p 50 mV max p-p	Main output 5 Vsb output Measured with a 0.1 µF ceramic and 10 µF tantalum capacitor on any output, 20 MHz
Output voltage overshoot	—	No overshoot/undershoot outside the regulation band during on or off cycle
Transient response	< 300 µs	50% load step @ 1 A/µs Step load valid between 10% to 100% of output rating Recovery time to within 1% of set point at onset of transient
Max units in parallel	—	Up to 10
Short circuit protection	Protection against damage	Bounce mode
Remote sense	—	Compensation up to 500 mV
Output isolation	—	Standard per safety requirements
Forced load sharing	To within 10% of all shared outputs	Analog sharing control
Overload protection (OCP)	105% to 125% 120% to 170%	Main output 5 Vsb output. Constant current or hiccup mode (software selectable)
Overvoltage protection (OVP)	125% to 145% 110% to 125%	12 V output 5 Vsb output
Overtemp protection	10-15 °C above safe operating area	Both PFC and output converter monitored

Ordering Information

Model Number*	Output	Nominal Output Voltage Set Point	Set Point Tolerance	Adjustment Range	Current		Output Ripple P/P (0-50 °C)	Max Continuous Power	Combined Line/ Load Regulation
					Min	Max			
LCM300L	12 V	12 V	±0.5%	9.6–14.4 V	0 A	25 A	120 mV	310	2%
LCM300N	15 V	15 V	±0.5%	12.0–19.5 V	0 A	20 A	150 mV	310	2%
LCM300Q	24 V	24 V	±0.5%	19.2–28.8 V	0 A	12.5 A	240 mV	310	2%
LCM300U	36 V	36 V	±0.5%	28.8–43.2 V	0 A	8.4 A	360 mV	310	2%
LCM300W	48 V	48 V	±0.5%	38.4–57.6 V	0 A	6.3 A	480 mV	310	2%

* For option codes, see Data Sheet

LCM600

Bulk front end

600 Watts

Total Power: 600 Watts
 # of Outputs: Single
 Output: 9.6-60 V
 Optional 5.0 V standby



Special Features

- 600 W output power
- Low cost
- 2.4" x 4.5" x 7.5"
- 7.41 W/cu-in
- 5 V SELV standby (housekeeping)
- Industrial/Medical safety
- -40 °C to 70 °C with derating
- 5 V housekeeping
- High efficiency: 89% typical
- Variable speed "Smart Fans"
- DSP controlled front end
- Conformal coat option
- ±20% adjustment range
- Margin programming
- OR-ing FET option
- Terminal block input option

Electrical Specifications

Input	
Input range	85-264 Vac (Operating) 115/230 Vac (Nominal) Input through standard IEC connector
Frequency	47-440 Hz, Nominal 50/60
Input fusing	Internal 10 A fuses, both lines fused
Inrush current	≤ 25 A peak, either hot or cold start
Power factor	0.99 typical, meets EN61000-3-2
Harmonics	Meets IEC 1000-3-2 requirements
Input current	8 A RMS max input current, at 100 Vac
Hold up time	20 ms minimum for Main O/P, at full rated load
Efficiency	> 88% at full load
Leakage current	< 0.3 mA at 264 Vac
ON/OFF power switch	N/A
Power line transient	MOV directly after the fuse



Environmental Specifications

Operating temperature	-40 °C to +70 °C, linear derating to 50% from 50 °C to 70 °C
Storage temperature	-40 °C to 85 °C
Humidity	20 to 90%, non-condensing. Operating. Conformal coat option available
Fan noise	< 45 dBA, 80% load at 30 °C
Altitude	Operating: Up to 16,405 feet above sea level Storage: Up to 30,000 feet above sea level
Shock	MIL-STD-810F 516.5, Procedure I, VI. Storage
Vibration	MIL-STD-810F 514.5, Cat. 4, 10. Storage

Safety

UL	60950-1 508/1598/1433 60601-1
CSA	60950-1
VDE	60950-1 60601
China	CCC
CB Scheme	Report/Cert

Electrical Specifications

Output		
Output rating	See ordering information table below	85-264 Vac
Set point	±0.5%	85-264 Vac
Total regulation range	Main output ±2% 5 Vsb ±1%	Combined line/load/transient when measured at output terminal
Rated load	600 W maximum	Derate linear to 50% from 50 °C to 70 °C
Minimum load	Main output @ 0.0 A 5 Vsb @ 0.0 A	No loss of regulation
Output noise (PARD)	1% max p-p 50 mV max p-p	Main output 5 Vsb output Measured with a 0.1 µF ceramic and 10 µF tantalum capacitor on any output, 20 MHz
Output voltage overshoot	—	No overshoot/undershoot outside the regulation band during on or off cycle
Transient response	< 300 µs	50% load step @ 1 A/µs Step load valid between 10% to 100% of output rating Recovery time to within 1% of set point at onset of transient
Max units in parallel	—	Up to 10
Short circuit protection	Protection against damage	Bounce mode
Remote sense	—	Compensation up to 500 mV
Output isolation	—	Standard per safety requirements
Forced load sharing	To within 10% of all shared outputs	Analog sharing control
Overload protection (OCP)	105% to 125% 120% to 170%	Main output 5 Vsb output. Constant current or bounce mode option through software
Overvoltage protection (OVP)	125% to 145% 110% to 125%	12 V output 5 Vsb output
Overtemp protection	10-15 °C above safe operating area	Both PFC and output converter monitored

Ordering Information

Model Number*	Output	Nominal Output Voltage Set Point	Set Point Tolerance	Adjustment Range	Current		Output Ripple P/P (0-50 °C)	Combined Line/ Load Regulation
					Min	Max		
LCM600L	12 V	12 V	±0.5%	9.6–14.4 V	0 A	54 A	120 mV	2%
LCM600N	15 V	15 V	±0.5%	12.0–19.5 V	0 A	44 A	150 mV	2%
LCM600Q	24 V	24 V	±0.5%	19.2–28.8 V	0 A	27 A	240 mV	2%
LCM600U	36 V	36 V	±0.5%	28.8–43.2 V	0 A	16.7 A	360 mV	2%
LCM600W	48 V	48 V	±0.5%	38.4–57.6 V	0 A	14 A	480 mV	2%

* For option codes, see Data Sheet

LCM1000

Bulk front end

1000 Watts

Total Power: 1000 W
 # of Outputs: Single
 Output: 12 to 48 V
 Optional 5.0 V standby



Special Features

- 1000 W output power
- Low cost
- 2.5" x 5.2" x 10.0"
- 7.7 Watts per cubic inch
- Industrial/Medical safety
- -40 °C to 70 °C with derating
- Optional 5 V @ 2 A housekeeping
- High efficiency: 90% typical
- Variable speed "Smart Fans"
- DSP controlled
- Conformal coat option
- ±10% adjustment range
- Margin programming
- OR-ing FET
- Low acoustic noise

Electrical Specifications

Input	
Input range	90 - 264 Vac (Operating) 115/230 Vac (Nominal) TERMINAL BLOCK
Frequency	47 - 440 Hz, Nominal 50/60
Input fusing	Internal 20 A fuses, both lines fused
Inrush current	≤ 25 A peak, either hot or cold start
Power factor	0.99 typical, meets EN61000-3-2
Harmonics	Meets IEC 1000-3-2 requirements
Input current	12 A RMS max input current, at 100 Vac
Hold up time	20 ms minimum for Main O/P, at full rated load
Efficiency	> 90% typical at full load / 230 Vac nominal
Leakage current	< 0.4 mA at 264 Vac
ON/OFF power switch	N/A
Power line transient	MOV directly after the fuse
Isolation	PRI-Chassis 2500 Vdc Basic PRI-SEC 4000 VAC Reinforced 2xMOPP SEC-Chassis 500 Vdc

Environmental Specifications

Operating temperature	-40 °C to +70 °C, linear derating to 75% from 60 °C to 70 °C
Storage temperature	-40 °C to +85 °C
Humidity	20 to 90%, non-condensing. Operating. Conformal coat option available
Fan noise	< 45 dBA, 100% load at 30 °C
Altitude	Operating - 16,405 feet (5,000 m) Storage - 30,000 feet
Shock	MIL-STD-810F 516.5, Procedure I, VI. Storage
Vibration	MIL-STD-810F 514.5, Cat. 4, 10. Storage

Safety

ULcUL Recognized ITE (UL60950-1)
ULcUL Recognized Medical (ANSI/AAMI ES60601-1)
TUV-SuD ITE + Medical (EN60950-1 and EN60601-1)
CE LVD (EN60950-1 + ROHS)
BSMI
CB Report
- Through Demko for IEC60950-1
- Through TUV-SuD for IEC60601-1
CCC Approval

Electrical Specifications

Output		
Output rating	See table 1	90-264 Vac
Set point	±0.5%	90-264 Vac
Total regulation range	Main output ±2% 5 Vsb ±1%	Combined line/load/transient when measured at output terminal
Rated load	1000 W maximum	Derate linear to 50% from 50 °C to 70 °C
Minimum load	Main output @ 0.0 A 5 Vsb @ 0.0 A	No loss of regulation
Output noise (PARD)	1% max p-p 50 mV max p-p	Main output 5 Vsb output Measured with a 0.1 µF Ceramic and 10 µF Tantalum Capacitor on any output, 20 MHz
Output voltage overshoot	—	No overshoot/undershoot outside the regulation band during on or off cycle
Transient response	< 300 µSec	50% load step @ 1 A/µs Step load valid between 10% to 100% of output rating Recovery time to within 1% of set point at onset of transient
Max units in parallel	—	Up to 10
Short circuit protection	Protected, no damage to occur	Bounce mode
Remote sense	—	Compensation up to 500 mV
Output isolation	—	Standard per safety requirements
Forced load sharing	To within 10% of all shared outputs	Analog sharing control
Overload protection (OCP)	105% to 125% 120% to 170%	Main output 5 Vsb output
Overvoltage protection (OVP)	125% to 145% 110% to 125%	12 V output 5 Vsb output
Overtemp protection	10 - 15 °C above safe operating area	Both PFC and output converter monitored

Ordering Information

Model Number*	Output	Nominal Output Voltage Set Point	Set Point Tolerance	Adjustment Range	Current		Output Ripple P/P (0-50 °C)	Max Continuous Power	Combined Line/Load Regulation
					Min	Max			
LCM1000L	12 V	12 V	±0.5%	10.8 – 13.2 V	0 A	83.3 A	120 mV	1000 W	2%
LCM1000N	15 V	15 V	±0.5%	13.5 – 16.5 V	0 A	66.7 A	150 mV	1000 W	2%
LCM1000Q	24 V	24 V	±0.5%	21.6 – 26.4 V	0 A	41.7 A	240 mV	1000 W	2%
LCM1000U	36 V	36 V	±0.5%	32.4 – 39.6 V	0 A	27.8 A	360 mV	1000 W	2%
LCM1000W	48 V	48 V	±0.5%	43.2 – 52.8 V	0 A	20.8 A	480 mV	1000 W	2%

* For option codes, see Data Sheet

LCM1500

Bulk front end

1500 Watts

Total Power: 1500 W
 # of Outputs: Single
 Output: 12 to 60 V
 Optional 5.0 V standby



Special Features

- 1500 W output power
- Low Cost
- 2.5" x 5.2" x 10.0"
- 12 Watts Per Cubic Inch
- Industrial/Medical safety
- -40 °C to 70 °C with derating
- Optional 5 V @ 2 A Housekeeping
- High Efficiency: 89% typical
- Variable speed "Smart Fans"
- DSP controlled
- Conformal coat option
- ±10% adjustment range
- Margin programming
- OR-ing FET
- Change to EMI Class A
- EN61000 Immunity
- RoHS 2
- PMBUS

Electrical Specifications

Input	
Input range	90 - 264 Vac (Operating) 115/230 Vac (Nominal) TERMINAL BLOCK
Frequency	47 - 440 Hz, Nominal 50/60
Input fusing	Internal 20 A fuses, both lines fused
Inrush current	≤ 25 A peak, either hot or cold start
Power factor	0.99 typical, meets EN61000-3-2
Harmonics	Meets IEC 1000-3-2 requirements
Input current	18 Arms max input current, at 100 Vac
Hold up time	20 ms minimum for Main O/P, at full rated load
Efficiency	> 91% typical at full Load/230 Vac nominal
Leakage current	< 0.3 mA at 264 Vac
ON/OFF power switch	N/A
Power line transient	MOV directly after the fuse
Isolation	PRI-Chassis 2500 Vdc Basic PRI-SEC 2500 Vdc Reinforced SEC-Chassis 500 Vdc

Environmental Specifications

Operating temperature	-40 °C to +70 °C, linear derating to 50% from 50 °C to 70 °C
Storage temperature	-40 °C to +85 °C
Humidity	20 to 90%, non-condensing. Operating. Conformal coat option available
Fan noise	< 45 dBA, 80% load at 30 °C
Altitude	Operating - 16,405 feet (5,000m) Storage - 30,000 feet
Shock	MIL-STD-810F 516.5, Procedure I, VI. Storage
Vibration	MIL-STD-810F 514.5, Cat. 4, 10. Storage

Safety

UL	60950-1 508/1598/1433 60601-1 Ed 3
CSA	60950-1
VDE	60950-1 60601
CB Scheme	Report/Cert

Electrical Specifications

Output		
Output rating	See ordering information table below	90-264 Vac
Set point	±0.5%	90-264 Vac
Total regulation range	Main output ±2% 5 Vsb ±1%	Combined line/load/transient when measured at output terminal
Rated load	1500 W maximum	Derate linear to 50% from 50 °C to 70 °C
Minimum load	Main output @ 0.0 A 5 Vsb @ 0.0 A	No loss of regulation
Output noise (PARD)	1% max p-p 50 mV max p-p	Main output 5 Vsb output Measured with a 0.1 µF ceramic and 10 µF tantalum capacitor on any output, 20 MHz
Output voltage overshoot	—	No overshoot/undershoot outside the regulation band during on or off cycle
Transient response	< 300 µs	50% load step @ 1 A/µs Step load valid between 10% to 100% of output rating Recovery time to within 1% of set point at onset of transient
Max units in parallel	—	Up to 10
Short circuit protection	Protection against damage	Bounce mode
Remote sense	—	Compensation up to 500 mV
Output isolation	—	Standard per safety requirements
Forced load sharing	To within 10% of all shared outputs	Analog sharing control
Overload protection (OCP)	105% to 125% 120% to 170%	Main output 5 Vsb output. Constant current or bounce mode option through software.
Overvoltage protection (OVP)	125% to 145% 110% to 125%	12 V output 5 Vsb output
Overtemp protection	10-15 °C above safe operating area	Both PFC and output converter monitored

Ordering Information

Model Number*	Output	Nominal Output Voltage Set Point	Set Point Tolerance	Adjustment Range	Current		Output Ripple P/P (0-50 °C)	Max Continuous Power	Combined Line/Load Regulation
					Min	Max			
LCM1500L	12 V	12 V	±0.5%	10.8–13.2 V	0 A	133 A	120 mV	1500	2%
LCM1500N	15 V	15 V	±0.5%	13.5–16.5 V	0 A	100 A	150 mV	1500	2%
LCM1500Q	24 V	24 V	±0.5%	21.6–26.4 V	0 A	67 A	240 mV	1500	2%
LCM1500R	28 V	28 V	±0.5%	25.2–30.8 V	0 A	53.6 A	280 mV	1500	2%
LCM1500U	36 V	36 V	±0.5%	32.4–39.6 V	0 A	43 A	360 mV	1500	2%
LCM1500W	48 V	48 V	±0.5%	43.2–52.8 V	0 A	33 A	480 mV	1500	2%

* For option codes, see Data Sheet

LCM3000

Bulk front end

3000 Watts

Total Power: 3000 W
of Outputs: Single
Output: 12 to 48 V

NEW!



Special Features

- 3000 W output power
- Low Cost
- 2.5" x 7.0" x 10.9"
- 15.7 Watts Per Cubic Inch
- Industrial/Medical safety
- -40 °C to 70 °C with derating
- Optional 5 V @ 2 A Housekeeping
- High Efficiency: 91% typical
- Variable speed "Smart Fans"
- DSP controlled
- Conformal coat option
- ±25% adjustment range
- Margin programming
- VAR configurable to any voltage from a single unit
- Five-year warranty

Electrical Specifications

Input	
Input range	90 - 264 Vac (Operating) Derate to 1500 W below 180 Vac input 115/230 Vac (Nominal) 129 - 370 Vdc TERMINAL BLOCK
Frequency	47 - 440 Hz, Nominal 50/60
Input fusing	Internal 30 A fuses, both lines fused
Inrush current	≤ 35 A peak, at 110 Vac and <60 A at 230 Vac
Power factor	0.99 typical, meets EN61000-3-2
Harmonics	Meets IEC 1000-3-2 requirements
Input current	20 A RMS max input current, at 100 Vac
Hold up time	14 ms minimum for nominal output voltage, at full rated load
Efficiency	> 91% typical at full load / 230 Vac nominal
Leakage current	< 0.4 mA at 264 Vac
ON/OFF power switch	N/A
Power line transient	MOV directly after the fuse
Isolation	PRI-Chassis 2500 Vdc Basic PRI-SEC 4000 VAC Reinforced 2xMOPP SEC-Chassis 500 Vdc

Environmental Specifications

Operating temperature	-40 °C to +70 °C, linear derating to 50% from 50 °C to 70 °C Operation at -40 °C requires a 5 minutes operating warm-up at -20 °C
Storage temperature	-40 °C to +85 °C
Humidity	10 to 90%, non-condensing. Operating. Conformal coat option available.
Acoustic noise	< TBD dBA, 80% load at 30 °C
Altitude	Operating - 16,405 feet (5,000 m) Storage - 30,000 feet
Shock	MIL-STD-810F 516.5, Procedure I, VI.
Vibration	MIL-STD-810F 514.5, Cat. 4, 10.

Safety

UL/cUL Recognized ITE (UL60950-1)
UL/cUL Recognized Medical (ANSI/AAMI ES60601-1)
TUV-SuD ITE + Medical (EN60950-1 and EN60601-1)
CE LVD (EN60950-1 + RoHS)
CQC under GB17625.1, GB4943, GB9254
CB Report
- through Demko for IEC60950-1
- through TUV-SuD for IEC60601-1
- through DEMKO for IEC62368-1

Electrical Specifications

Output		
Output rating	See table 1	180 - 264 Vac
Set point	±0.5%	90-264 Vac
Total regulation range	Main output ± 1% 5 Vsb ± 5%	Combined line/load when measured at output terminal
Rated load	3000 W maximum (Derate to 2000 W when input is <180 Vac)	Derate linear to 50% from 50 °C to 70 °C
Minimum load	Main output @ 0.0 A 5 Vsb @ 0.0 A	No loss of regulation
Output noise (PARD)	1% max p-p 100 mV max p-p	Main output 5 Vsb output Measured with a 0.1 µF Ceramic and 10 µF Tantalum Capacitor on any output, 20 MHz
Output voltage overshoot	<3% of voltage setting must settle within 300 mSec	Rise is monotonic
Transient response	< 300 µSec	50% load step @ 1 A/µs Step load valid between 10% to 100% of output rating Recovery time to within 1% of set point at onset of transient
Max units in parallel	—	Up to 8
Short circuit protection	Protected, no damage to occur	Bounce mode
Remote sense	—	Compensation up to 500 mV
Output isolation	—	Standard per safety requirements
Forced load sharing	To within 10% of all shared outputs	Digital sharing control
Overload protection (OCP) – Constant current mode	105% to 125% 120% to 170%	Main output 5 Vsb output
Overvoltage protection (OVP)	125% to 145% 110% to 125%	12 V output 5 Vsb output
Overtemperature protection	10 - 15 °C above safe operating area	Both PFC and output converter monitored

Ordering Information

Model Number*	Nominal Output Voltage Set Point	Adjustment Range		Max I	Output Ripple P/P (0-50 °C)	Combined Line/Load Regulation	Trim Range ± 25%	"Vprog Adjustment" 0 V to 6 V (20% to 125% Vout)
		Max I	Max Power (3000 W)					
LCM3000L-T	12 V	2.4 V - 12 V	12 V - 15 V	250 A	120 mV OR 1% whichever is higher	1%	9 V - 15 V	2.4 V - 15 V
LCM3000O-T	18 V	3.6 V - 18 V	18 V - 22.5 V	166.7 A	180 mV OR 1% whichever is higher	1%	13.5 V - 22.5 V	3.6 V - 22.5 V
LCM3000Q-T	24 V	4.8 V - 24 V	24 V - 30 V	125 A	240 mV OR 1% whichever is higher	1%	18 V - 30 V	4.8 V - 30 V
LCM3000U-T	36 V	7.2 V - 36 V	36 V - 45 V	83.3 A	360 mV OR 1% whichever is higher	1%	27 V - 45 V	7.2 V - 45 V
LCM3000W-T	48 V	9.6 V - 48 V	48 V - 60 V	62.5 A	480 mV OR 1% whichever is higher	1%	36 V - 60 V	9.6 V - 60 V
LCM30007-T	72 V	14.4 V - 72 V	72 V - 90 V	41.7 A	720 mV OR 1% whichever is higher	1%	54 V - 90 V	14.4 V - 90 V

Notes:

- (1) Minimum Current is (0)
- (2) Set Point Tolerance is ±0.5%
- (3) outputs above 60 Vdc are not SELV rated.

HPS & UFE

Distributed power bulk front end

3000-12000 Watts

Special Features

- EN61000-3-2 harmonic compliance
- Built-in EMI filter
- Low output ripple
- +5 V standby output
- Built-in cooling fans
- N + 1 redundant
- Overcurrent protection
- Overvoltage protection
- Overtemperature protection
- Built-in OR-ing diodes
- Active power factor correction



Voltage Availability

Model	HPS3000	UFE
Wattage	3000 W ³	2000 W ⁴
Input Voltage	90-140 Vac 180-264 Vac	90-265 Vac
Available Standard Output Voltages (order code) ¹		
12 (L)		
24 (Q)		●
28 (R)		●
30 (S)		
48 (W)	●	●
54 (X)		●
60 (Y)		
Available Options	See Note 1	
Corresponding Rack	See Note 2	UFR6000J

Notes: 1 = Consult factory for other output voltages and options
 2 = Comes with optional I²C interface
 3 = 3000 W @ 180-264 Vac; 1500 W @ 90-140 Vac
 4 = 2000 W @ 48 V; 1300 W @ 24 V

HPS3000 Electrical Specifications

Input	
Input range (operating)	180-264 Vac 90-140 Vac
Input range (nominal)	200 Vac 110 Vac
Frequency	43-63 Hz
Input fusing	Internal 25 A fuses (both lines fused)
Inrush current	≤ 40 A peak (either hot or cold start)
Power factor	0.97 typical (Meets EN61000-3-2)
Harmonics	Meets IEC 1000-3-2 requirements @ 50% load
Input current	19 A max input current
Holdup time	10 ms min @ full rated load
Leakage current	1.4 mA @ 240 Vac
Power line transient	MOV directly after the fuse

Environmental Specifications

HPS3000	
Operating temp.	-10 °C to 40 °C
Storage temp.	-40 °C to 85 °C
Cooling	External fans with Fan Fail and Fan Speed control
Humidity	Operating/Storage: 5-95% non-condensing
Altitude	Operating: Up to 10,000 feet above sea level Storage: Up to 30,000 feet above sea level
Vibration/Shock	Non-operational 5G Sine sweep from 5-500 Hz, dwelling at resonant frequencies for one hour each
RoHS compliant	Yes

Safety

UL	UL60950 (UL recognized)
NEMKO	EN60950
TÜV	EN60950
CE	Mark
CB	Report



HPR12K

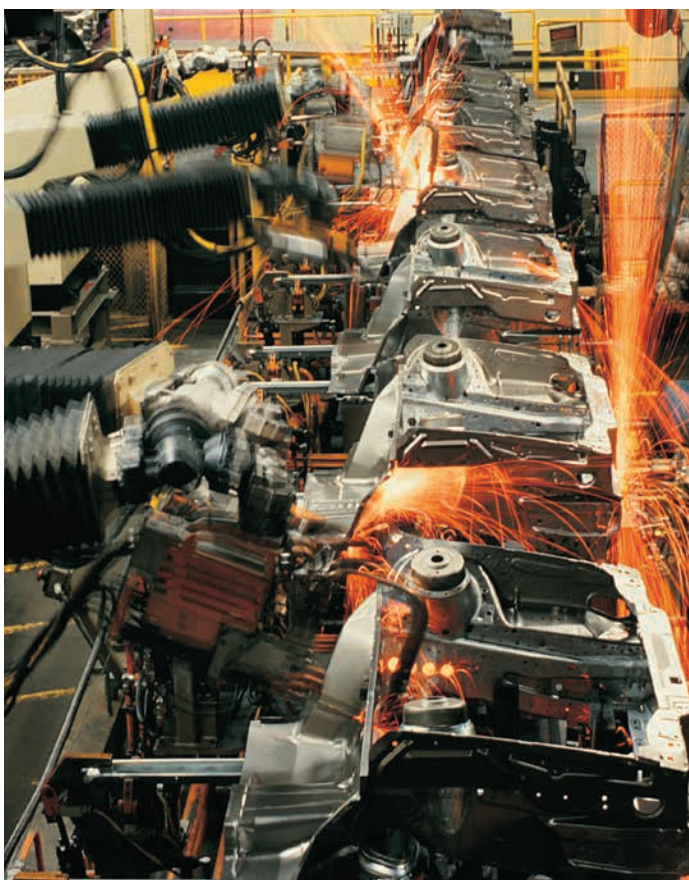

Output	
Output rating	48 V @ 62.0 A (180-264 Vac) 5 Vsb @ 3.0 A
	48 V @ 29.4 A (90-140 Vac) 5 V @ 3 A
Set point	-4% to +17% through I ² C
Total regulation range	48 V ±10%; 5 Vsb ±4% (line/load/transient when measured at output connection)
Rated load	3000 W maximum @ 200 Vac Input 1500 W maximum @ 110 Vac Input (no derating over operating temperature range)
Minimum load	48 V @ 0.0 A; 5 Vsb @ 0.0 A with no loss of regulation
Output noise	480 mV max P-P for 48 V output 100 mV max P-P for 5 Vsb output Measured with a 0.1F Ceramic and 10 F Tantalum capacitor on any input
Output voltage overshoot	±5% maximum of nominal voltage setting
Transient response	5% maximum deviation (50% load step @ 1 A/μs. Step load valid between 10-100% of output rating)
Max units in parallel	Up to 4 (total power in 1U 19" rack is 12 KW)
Short circuit protection	120-130% of rated output (output to return)
Forced load sharing	Within 10% of all shared outputs (digital sharing control)
Overcurrent protection (OCP)	120-130% for 48 V output 100-125% for 5 Vsb output
Overvoltage protection (OVP)	110-120% for 48 V output 110-125% for 5 Vsb output
Overtemperature protection	10 °C to 15 °C above safe operating area. (Both PFC and output converter monitored. 5 Vsb will operate under overtemperature condition. Built-in hysteresis.)

Rack Ordering Information

Module	UFE1300/2000	HPS3000
Rack #	UFR6000	HPR12K
# of Slots	3	4
Total Power	6000 W	12000 W

** See website for option codes on HPR racks.

Ordering Information

HPS3000-9-001	High airflow performance	HPR120K-00-001
HPS3000-9	Standard fans	HPR12K-00

UFE1300/2000 Electrical Specifications

Input	
Input range (operating)	88-264 Vac 176-264 Vac
Input range (nominal)	120 Vac 240 Vac
Frequency	47-63 Hz
Input fusing	30 A (both lines fused)
Power factor	0.98 (50-100% load)
Input current	15 A max.
Leakage current	2 mA max.
Undervoltage lockout (power up)	176 Vac max. (high line range) 88 Vac max. (wide range)
Undervoltage lockout (power down)	162 Vac min. (high line range) 76 Vac min. (wide range)

Output	
Output rating - Main output	48 V 2000 W (high line range) 48 V 1300 W (wide range) 24 V 1300 W (all ranges)
Output rating - Auxiliary output	11 V \pm 15%, 2.875 W
Line regulation	\pm 0.15% max.
Load regulation	\pm 0.15% max.
Turn-on delay	5.0 seconds max.
Ambient temp. coefficient	\pm 0.005%/°C
Voltage adjustability (via PMBus)	48 V 42-57 Vdc 24 V 21-28.5 Vdc
Output setpoint accuracy	\pm 0.5%
Default output voltage (@ 25 °C)	48 V \pm 0.5% @ 41 A 27 V \pm 0.5% @ 48 A
Total error band	\pm 1.0% max.
Overshoot/undershoot	0%
Ripple and noise (20 MHz)	500 mV pk-pk, 150 mV rms
Dynamic regulation (except droop mode)	2.5% max., recovery in 1 ms max.
Current sharing	15% max.
Electrical insulation	4242 Vdc input/output
Switching frequency	450 kHz fixed
Power limit	115%
Current limit	108% typical
Short-circuit	200 ms on; 1/8 second off
Overvoltage	60 V/32 V
Overtemperature	Non-latching

UFE Power Shelf



UFE2000

Ordering Information

Rated Output Power	Output Voltage Vout		Output Current (Min)	Power Limit + 15% / -0% Vout (min)	Line Range at Turn On (Auto Ranging)	Operating Line Range	Current Limit (Vout) < Vout (min)	Model Numbers	Order Number
	Min	Max							
24 Vout Models									
1300 W	21 V	28.5 V	0 A	1300 W	90-264 Vac	65 A	65 A	UFE1300-96S24PJ	UFE1300-5
48 Vout Models									
1300 W	42 V	57 V	0 A	1300 W	90-264 Vac	33 A	33 A	UFE2000-96S48PJ	UFE2000-9
2000 W	42 V	57 V	0 A	2000 W	180-264 Vac	52 A	52 A		
1300 W	42 V	57 V	0 A	1300 W	90-264 Vac	33 A	33 A	UFE2000-96S48PDJ	UFE2000-9-HD
2000 W	42 V	57 V	0 A	2000 W	180-264 Vac	52 A	52 A		
1300 W	42 V	57 V	0 A	1300 W	90-264 Vac	33 A	33 A	UFE2000-96S48PHDJ	UFE2000-9-D
2000 W	42 V	57 V	0 A	2000 W	180-264 Vac	52 A	52 A		

Product Family	Rated Output Power	Input Range	Standard Compliance	Type of Output	Output Voltage	Communications Type	Option Code	Special Modification	RoHS Compliance
UFE	2000	9	6	S	48	P	D	xx	J
UFE = Universal Front-End	1300 = 1300 Watts 2000 = 2000 Watts	9 = Universal Input with PFC	6 = UL/CSA/VDE Class A/B	S = Single	48 = 48 V 24 = 24 V	P = PMBus serial communications	None = Active Ishare D = Droop Ishare HD = PS Enable HI/Droop		J = Pb free (RoHS 6/6 compliant)

Distributed and CRPS Power Systems

AC and DC inputs available

450-3000 Watts



DS450DC

Special Features

- Active power factor correction
- EN61000-3-2 harmonic compliance
- Active AC inrush control
- High density
- Outputs +12 Vdc with some +48 Vdc models available
- 3.3 Vdc standby
- 12.0 Vdc standby on some models
- Options for 5 V standby voltage
- No minimum load required
- Hot plug operation
- N+1 redundant
- Internal OR-ing FETs
- Active current sharing
- Built-in cooling fans
- I²C Interface with EEPROM for FRU data
- Internal fan speed control with fan fail signal
- DC Input
- DSR1 rack for DS650/850. Ordering part number is 73-762-002. Standard 19" 1U fits up to 5 modules (4250 Watts)
- Options for reverse airflow
- Platinum Plus efficiency on some models

Voltage Availability

Model	12 V	24 V	48 V	PMBus
	(-3)	(-5)	(-9)	
DS450	●			
DS450DC	●			
DS460S	●			●
DS460SDC	●			●
DS495SPE	●			
DS500SDC	●			
DS550	●			
DS550DC	●			
DS650	●	●	●	
DS650DC	●			
DS750PED	●			
DS760SL	●			
DS800SL	●			●
DS850	●	●	●	
DS850DC	●			
DS1050	●			●
DS1100PED	●			
DS1100SDC	●			
DS1100SLPE	●			
DS1100TDC-3	●			
DS1200	●			●
DS1200DC	●			●
DS1600SPE	●			
DS2000	●			●
DS2000SPE	●			
DS2400SPE	●			
DS2500PE	●			
DS2700DC	●			
DS3000DC	●			
DS3000TE	●			

Notes: ● Available

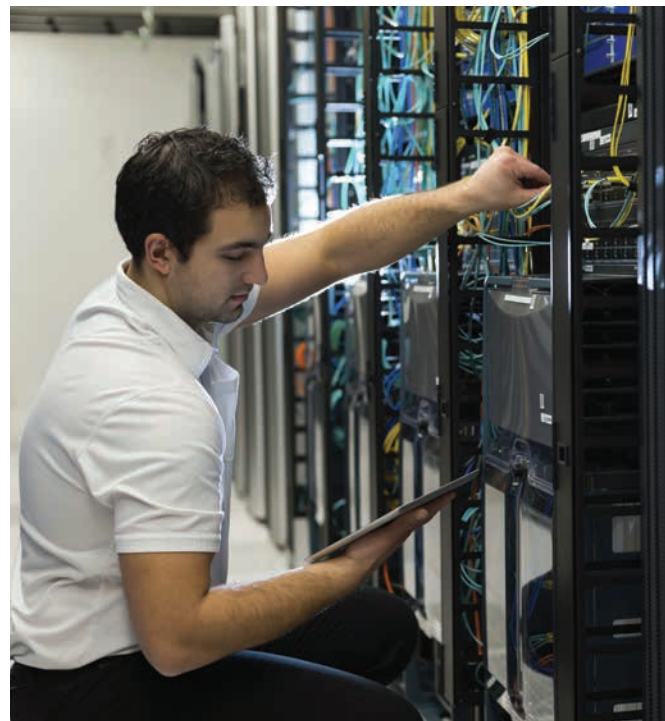

Safety

UL	UL60950 (UL recognized)
NEMKO	EN60950
TÜV	EN60950
CE	Mark
CB	Report



DS460



DS495SPE-3



DS500SDC-3

Electrical Specifications

	DS450-3	DS450DC-3	DS460S-3	DS460SDC	DS495SPE-3	DS500SDC-3
Input						
Input Range	90-264 Vac	40-72 Vdc	90-264 Vac	40-72 Vdc	90-264 Vac	-36 to -72 Vdc
Frequency	47-63 Hz	DC	47-63 Hz	DC	47-63 Hz	N/A
Efficiency	80% Typ	80% Typ	92% Typ	92% Typ	94% Typ Platinum	90% Typ
EMI/RFI	Class B	N/A	Class B	N/A	Class A	Class A
Leakage Current	1.4 mA @ 240 V	N/A	1.0 mA @ 240 V	N/A	1.0 mA	N/A
Outputs						
Output Main	12 V / 37 A	12 V / 37 A	12 V / 38.2 A	12 V / 38.2 A	12 V / 41.2 A	12 V / 41.6 A
Output Stand-By	3.3 Vsb / 3 A	3.3 Vsb / 3 A	12 Vsb / 2.5 A	12 Vsb / 2.5 A	12 V / 3.0 A	12 V / 3.0 A
OCP/OVP/OTP	YES	YES	YES	YES	YES	YES
I ² C Control	YES	YES	YES	YES	YES	YES
Environmental						
Operating Temp	-10 °C to 50 °C	-10 °C to 50 °C	-10 °C to 50 °C	-10 °C to 50 °C	0 °C to 50 °C	0 °C to 50 °C
Derating	N/A	N/A	N/A	N/A	N/A	N/A
Storage	-40 °C to +85 °C	-40 °C to +85 °C	-40 °C to +85 °C	-40 °C to +85 °C	-40 °C to 70 °C	-40 °C to 70 °C
RoHS Compliant	YES	YES	YES	YES	YES	YES
MTBF	300K Hours	500K Hours	500K Hours	500K Hours	> 900K Hours	> 500K Hours
Other						
Size (inch)	1.57 x 3.07 x 11.05	1.57 x 3.07 x 11.05	1.57 x 3.4 x 7.75	1.57 x 3.4 x 7.75	1.57 x 3.39 x 7.73	1.57 x 3.39 x 7.73
Size (mm)	40 x 78 x 280	40 x 78 x 280	40 x 86.4 x 197	40 x 86.4 x 197	40 x 86.3 x 196.5	40 x 86.3 x 196.5
Power Density	8.42	8.42	11.12	11.12	12.2	12.2
Cubic Inches	53.42	53.42	41.37	41.37	41.14	41.14
Pro-E Files	NO	YES	YES	YES	YES	YES
Thermal Data	YES	YES	YES	YES	YES	YES
PQ Airflow Curves	YES	YES	YES	YES	YES	YES
Warranty	Two Years	Two Years	Two Years	Two Years	Two Years	Two Years
Ordering Codes						
Standard	DS450-3	DS450DC-3	DS460S-3-002 DS460S-3-004 (CCC 5,000m altitude)	DS460SDC-3	DS495SPE-3	DS500SDC-3
ALT Standby	DS450-3-001					
Reverse Air	DS450-3-002	DS450DC-3-002	DS460S-3-003 DS460S-3-005 (CCC 5,000m altitude)	DS460SDC-3-001	DS495SPE-3-001	DS500SDC-3-001



DS550DC



DS650

	DS550-3	DS550DC-3	DS650-3	DS650-5	DS650-9	DS650DC-3
Input						
Input Range	90-264 Vac	40-72 Vdc	90-264 Vac	90-264 Vac	90-264 Vac	40-72 Vdc
Frequency	47-63 Hz	DC	47-63 Hz	47-63 Hz	47-63 Hz	DC
Efficiency	80% Typ	80% Typ	80% Typ	80% Typ	82% Typ	80% Typ
EMI/RFI	Class B	N/A	Class B	Class B	Class B	N/A
Leakage Current	1.4 mA @ 240 V	N/A	1.4 mA @ 240 V	1.4 mA @ 240 V	1.4 mA @ 240 V	N/A
Outputs						
Output Main	12 V / 45 A	12 V / 45 A	12 V / 52.5 A	24 V / 26.3 A	48 V / 13.1 A	12 V / 52.5 A
Output Stand-By	3.3 Vsb / 3 A	3.3 Vsb / 3 A	3.3 Vsb / 6 A	3.3 Vsb / 6 A	3.3 Vsb / 6 A	3.3 Vsb / 6 A
OCP/OVP/OTP	YES	YES	YES	YES	YES	YES
ƒC Control	YES	YES	YES	YES	YES	YES
Environmental						
Operating Temp	-10 °C to 50 °C	-10 °C to 50 °C	-10 °C to 50 °C	-10 °C to 50 °C	-10 °C to 50 °C	-10 °C to 50 °C
Derating	N/A	N/A	50% at 70 °C	50% at 70 °C	50% at 70 °C	50% at 70 °C
Storage	-40 °C to +85 °C	-40 °C to +85 °C	-40 °C to +85 °C	-40 °C to +85 °C	-40 °C to +85 °C	-40 °C to +85 °C
RoHS Compliant	YES	YES	YES	YES	YES	YES
MTBF	300K Hours	500K Hours	500K Hours	500K Hours	500K Hours	500K Hours
Other						
Size (inch)	1.57 x 3.07 x 11.05	1.57 x 3.07 x 11.05	1.57 x 3.20 x 11.00	1.57 x 3.20 x 11.00	1.57 x 3.20 x 11.00	1.57 x 3.20 x 11.00
Size (mm)	40 x 78 x 280	40 x 78 x 280	40 x 81.3 x 279.4	40 x 81.3 x 279.4	40 x 81.3 x 279.4	40 x 81.3 x 279.4
Power Density	10.30	10.30	11.76	11.76	11.76	11.76
Cubic Inches	53.42	53.42	55.44	55.44	55.44	55.44
Pro-E Files	NO	YES	YES	YES	YES	YES
Thermal Data	YES	YES	YES	YES	YES	YES
PQ Airflow Curves	YES	YES	YES	YES	YES	YES
Warranty	Two Years	Two Years	Two Years	Two Years	Two Years	Two Years
Ordering Codes						
Standard	DS550-3	DS550DC-3/	DS650-3	DS650-5	DS650-9	DS650DC-3
ALT Standby						DS650DC-3-002
Reverse Air		DS550DC-3-003	DS650-3-007			DS650DC-3-003
ALT Standby & Reverse Air						DS650DC-3-004
Disable External Fan Drive				DS650DC-3-001		



DS750PED



DS800SL



DS760SL



DS850

	DS750PED-3	DS760SL-3	DS800SL-3	DS850-3	DS850-5	DS850-9
Input						
Input Range	90-264 Vac	90-264 Vac	90-264 Vac	90-264 Vac	90-264 Vac	90-264 Vac
Frequency	47-63 Hz	47-63 Hz	47-63 Hz	47-63 Hz	47-63 Hz	47-63 Hz
Efficiency	94% Typ	90% Typ	92% Typ	82% Typ	82% Typ	83% Typ
EMI/RFI	Class A	Class A	Class B	Class B	Class B	Class B
Leakage Current	1.75 mA @ 240 V	0.8 mA @ 240 V	0.8 mA @ 240 V	1.4 mA @ 240 V	1.4 mA @ 240 V	1.4 mA @ 240 V
Outputs						
Output Main	12 V / 62.5 A	12 V / 62.3 A	12 V / 66.7 A	12 V / 70 A	24 V / 35 A	48 V / 17.5 A
Output Stand-By	12 V / 3 A	5.0 Vsb / 3.6 A	5.0 Vsb / 4 A	3.3 Vsb / 6 A	3.3 Vsb / 6 A	3.3 Vsb / 6 A
OCP/OVP/OTP	YES	YES	YES	YES	YES	YES
°C Control	YES	YES	YES	YES	YES	YES
Environmental						
Operating Temp	0 °C to 50 °C	0 °C to 50 °C	0 °C to 50 °C	-10 °C to 50 °C	-10 °C to 50 °C	-10 °C to 50 °C
Derating	N/A	N/A	N/A	50% at 70 °C	50% at 70 °C	50% at 70 °C
Storage	-40 °C to +70 °C	-40 °C to +85 °C	-40 °C to +85 °C	-40 °C to +85 °C	-40 °C to +85 °C	-40 °C to +85 °C
RoHS Compliant	YES	YES	YES	YES	YES	YES
MTBF	200K Hours	300K Hours	500K Hours	500K Hours	500K Hours	500K Hours
Other						
Size (inch)	1.57 x 3.39 x 7.74	1.57 x 2.15 x 12.68	1.57 x 2.15 x 12.68	1.57 x 3.20 x 11.00	1.57 x 3.20 x 11.00	1.57 x 3.20 x 11.00
Size (mm)	41 x 86.3 x 196.5	40 x 54.5 x 322	40 x 54.5 x 322	40 x 81.3 x 279.4	40 x 81.3 x 279.4	40 x 81.3 x 279.4
Power Density	18.23	17.76	18.69	15.38	15.38	15.38
Cubic Inches	41.14	42.8	42.8	55.44	55.44	55.44
Pro-E Files	YES	YES	YES	YES	YES	YES
Thermal Data	YES	YES	YES	YES	YES	YES
PQ Airflow Curves	YES	YES	YES	YES	YES	YES
Warranty	Two Years	Two Years	Two Years	Two Years	Two Years	Two Years
Ordering Codes						
Standard	DS750PED-3	DS760SL-3	DS800SL-3	DS850-3	DS850-5	DS850-9
ALT Standby		DS760SL-3-002		DS850-3-005		
Reverse Air	DS750PED-3-001	DS760SL-3-001	DS800SL-3-001	DS850-3-006		
ALT Standby & Reverse Air		DS760SL-3-003				



DS850DC



DS1100PED



DS1100TDC

	DS850DC-3	DS1050-3	DS1100PED-3	DS1100SDC-3	DS1100SLPE-3	DS1100TDC-3
Input						
Input Range	40-72 Vdc	90-264 Vac	90-264 Vac	-36 to -72 Vdc	90-264 Vac	-40 to -72 Vdc
Frequency	DC	47-63 Hz	47-63 Hz	N/A	47-63 Hz	N/A
Efficiency	80% Typ	92% Typ GLD	94% Typ	90% Typ	94% Typ	90% Typ
EMI/RFI	N/A	Class B	Class A	Class A	Class A	Class A
Leakage Current	N/A	1.4 mA @ 240 V	1.75 mA @ 240 V	N/A	1.75 mA	N/A
Outputs						
Output Main	12 V / 70 A	12 V / 85.5 A	12 V / 91.67 A	12 V / 91.67 A	12 V / 90 A	12 V / 91.67 A
Output Stand-By	3.3 Vsb / 6 A	3.3 Vsb / 6 A	12 V / 3 A	12 V / 3 A	3.3 V / 3 A	3.3 V / 3 A
OCP/OVP/OTP	YES	YES	YES	YES	YES	YES
ƒC Control	YES	YES	YES	YES	YES	YES
Environmental						
Operating Temp	-10 °C to 50 °C	-10 °C to 50 °C	0 °C to 50 °C	0 °C to 50 °C	0 °C to 50 °C	0 °C to 50 °C
Derating	50% at 70 °C	50% at 70 °C	N/A	N/A	60% at 65 °C	N/A
Storage	-40 °C to +85 °C	-40 °C to +85 °C	-40 °C to +70 °C	-40 °C to 70 °C	-40 °C to +85 °C	-40 °C to 70 °C
RoHS Compliant	YES	YES	YES	Yes	YES	YES
MTBF	500K Hours	500K Hours	200K Hours	> 200K Hours	300K Hours	> 300K Hours
Other						
Size (inch)	1.57 x 3.20 x 11.00	1.57 x 3.20 x 11.00	1.57 x 3.39 x 7.75	1.57 x 3.39 x 7.75	1.57 x 2.15 x 12.66	1.57 x 2.14 x 12.67
Size (mm)	40 x 81.3 x 279.4	40 x 81.3 x 279.4	42 x 86.3 x 196.5	42 x 86.3 x 196.5	40 x 54.6 x 321.56	40 x 54.5 x 322.0
Power Density	15.38	18.95	26.74	26.7	25.7	25.8
Cubic Inches	55.44	55.44	41.14	41.14	42.73	42.57
Pro-E Files	YES	YES	YES	YES	YES	YES
Thermal Data	YES	YES	YES	YES	YES	YES
PQ Airflow Curves	YES	YES	YES	YES	YES	YES
Warranty	Two Years	Two Years	Two Years	Two Years	Two Years	Two Years
Ordering Codes						
Standard	DS850DC-3	DS1050-3	DS1100PED-3	DS1100SDC-3	DS1100SLPE-3	DS1100TDC-3
ALT Standby	DS850DC-3-003	DS1050-3-002				
Reverse Air	DS850DC-3-004	DS1050-3-001	DS1100PED-3-001	DS1100SDC-3-001	DS1100SLPE-3-001	DS1100TDC-3-001
ALT Standby & Reverse Air		DS1050-3-003				



DS2000SPE-3



DS2000-3



DS2400SPE-3

NEW!

	DS1600SPE-3	DS2000-3	DS2000SPE-3	DS2400SPE-3
Input				
Input Range	180-264 Vac	90-264 Vac	90-140 Vac/180-264 Vac	90-140 Vac/180-264 Vac
Frequency	47-63 Hz	47-63 Hz	47-63 Hz	47-63 Hz
Efficiency	94% Typ	87% Typ	94% Typ Platinum	94% Typ Platinum
EMI/RFI	Class A	Class B	Class A	Class A
Leakage Current	1.75 mA @ 240 V	1.4 mA @ 240 V	0.75 mA	0.6 mA
Outputs				
Output Main	12 V / 133.3 A ¹	12 V / 165 A ¹	12 V / 163.9 A ¹	12.2 V / 196.7 A ¹
Output Stand-By	12 V / 4.5 A	3.3 Vsb / 9 A	12 V / 3.5 A	12 V / 3.5 A
OCP/OVP/OTP	YES	YES	YES	YES
I ² C Control	YES	YES	YES	YES
Environmental				
Operating Temp	0 °C to 50 °C	-10 °C to 50 °C	0 °C to 50 °C	0 °C to 50 °C
Derating	70% at 60 °C	N/A	N/A	70% at 60 °C
Storage	-40 °C to +85 °C	-40 °C to +85 °C	-40 °C to 70 °C	-40 °C to 70 °C
RoHS Compliant	YES	YES	YES	YES
MTBF	200K Hours	500K Hours	> 500K Hours	500K Hours
Other				
Size (inch)	1.57 x 3.39 x 7.76	1.57 x 4.2 x 11.6	1.57 x 3.39 x 7.75	1.57 x 3.39 x 7.75
Size (mm)	40 x 86.3 x 196.5	40 x 106.7 x 295.7	40 x 86.3 x 196.5	40 x 86.3 x 196.5
Power Density	38.89	26.2	48.6	58.2
Cubic Inches	41.14	76.5	41.14	41.14
Pro-E Files	YES	YES	YES	YES
Thermal Data	YES	YES	YES	YES
PQ Airflow Curves	YES	YES	YES	YES
Warranty	Two Years	Two Years	Two Years	Two Years
Ordering Codes				
Standard	DS1600SPE-3	DS2000-3	DS2000SPE-3	DS2400SPE-3
ALT Standby		DS2000-3-002		DS2400SPE-3-001
Reverse Air	DS1600SPE-3-001	DS2000-3-001	DS2000SPE-3-001	
ALT Standby & Reverse Air				

¹ Low line derating will apply

DS2500PE-3



DS3000



NEW!

NEW!

	DS2500PE-3	DS3000DC-3	DS3000TE-3
Input			
Input Range	180-264 Vac	-40 to -72 Vdc	208-264 Vac
Frequency	47-63 Hz	N/A	47-63 Hz
Efficiency	94% Typ	90% Typ	96% Typ Titanium
EMI/RFI	Class A	Class A	Class A
Leakage Current	0.75 mA @ 240 V	N/A	0.75 mA
Outputs			
Output Main	12 V / 208.3 A	12 V / 248 A	12 V / 250 A
Output Stand-By	3.3 V / 2.7 A	12 V / 4.5 A	12 V / 4.5 A
OCP/OVP/OTP	YES	YES	YES
I ² C Control	YES	YES	YES
Environmental			
Operating Temp	10 °C to 50 °C	0 °C to 40 °C	0 °C to 40 °C
Derating	N/A		25% at 50 °C
Storage	-40 °C to +60 °C	-40 °C to 70 °C	-40 °C to 85 °C
RoHS Compliant	YES	YES	YES
MTBF	750K Hours	> 400K Hours	400K Hours
Other			
Size (inch)	1.69 x 5.47 x 10.63	4.15 x 2.78 x 11.8	4.15 x 2.78 x 11.12
Size (mm)	42.9 x 139 x 270	105.5 x 70.6 x 299.7	105.5 x 70.6 x 282.6
Power Density	25.44	22.0	26.26
Cubic Inches	98.27	136	114.23
Pro-E Files	YES	YES	YES
Thermal Data	YES	YES	YES
PQ Airflow Curves	YES	YES	YES
Warranty	Two Years	Two Years	Two Years
Ordering Codes			
Standard	DS2500PE-3	DS3000DC-3	DS3000TE-3
ALT Standby			
Reverse Air		DS3000DC-3-001	DS3000TE-3-001
ALT Standby & Reverse Air			



CSU800AP-3



CSU2000AP-3



CSU2400AP-3

NEW!

NEW!

NEW!

NEW!

	CSU550AP-3	CSU800AP-3	CSU1300AP-3	CSU1800AP-3	CSU2000AP-3	CSU2400AP-3
Input						
Input Range	90-264 Vac	90-264 Vac	90-264 Vac	90-264 Vac	90-264 Vac	90-264 Vac
Frequency	47-63 Hz	47-63 Hz	47-63 Hz	47-63 Hz	47-63 Hz	47-63 Hz
Efficiency	94% Typ Platinum	94% Typ Platinum	94% Typ Platinum	94% Typ Platinum	94% Typ Platinum	94% Typ Platinum
EMI/RFI	Class A	Class A	Class A	Class A	Class A	Class A
Leakage Current	0.85 mA	1.75 mA	1.75 mA	0.6 mA	0.6 mA	0.6 mA
Outputs						
Output Main	12 V / 45.0 A	12 V / 66.7 A	12.2 V / 108.3 A	12.2 V / 147.5 A	12.2 V / 163.9 A ¹	12.2 V / 196.7 A
Output Stand-by	12 V / 2.5 A	12 V / 2.5 A	12 V / 3.5 A	12 V / 3.5 A	12 V / 3.5 A	12 V / 3.5 A
OCP/OVP/OTP	YES	YES	YES	YES	YES	YES
I ² C Control	YES	YES	YES	YES	YES	YES
Environmental						
Operating Temp	0 °C to 50 °C	0 °C to 50 °C	0 °C to 55 °C	0 °C to 55 °C	0 °C to 55 °C	0 °C to 55 °C
Derating						
Storage	-40 °C to 70 °C	-40 °C to 70 °C	-40 °C to 70 °C	-40 °C to 70 °C	-40 °C to 60 °C	-40 °C to 70 °C
RoHS Compliant	YES	YES	YES	YES	YES	YES
MTBF	> 250K Hours	> 250K Hours	> 250K Hours	> 250K Hours	> 250K Hours	> 250K Hours
Other						
Size (inch)	1.57 x 2.89 x 7.28	1.57 x 2.89 x 7.28	1.57 x 2.89 x 7.28	1.57 x 2.89 x 7.28	1.57 x 2.89 x 7.28	1.57 x 2.89 x 7.28
Size (mm)	40 x 73.5 x 185	40 x 73.5 x 185	40 x 73.5 x 185	40 x 73.5 x 185	40 x 73.5 x 185	40 x 73.5 x 185
Power Density	16.7	16.7	40.6	56	62.6	75
Cubic Inches	33	33	33	33	33	33
Pro-E files	YES	YES	YES	YES	YES	YES
Thermal Data	YES	YES	YES	YES	YES	YES
PQ Airflow Curves	YES	YES	YES	YES	YES	YES
Warranty	Two years	Two years	Two years	Two years	Two years	Two years
Ordering Codes						
Standard	CSU550AP-3	CSU800AP-3	CSU1300AP-3	CSU1800AP-3-100	CSU2000AP-3-100 ² CSU2000AP-3-200 ³	CSU2400AP-3-100
ALT Standby						
Reverse Air	CSU550AP-3-001	CSU800AP-3-001	CSU1300AP-3-001	CSU1800AP-3-101	CSU2000AP-3-101 ² CSU2000AP-3-201 ³	CSU2400AP-3-101
ALT Standby & Reverse Air						

¹ Low line derating will apply

² IEC C14 AC inlet

³ IEC C20 AC inlet



CSV1100BP-3



CSV1600BP-3



CSV2000BP-3

NEW!

NEW!

NEW!

NEW!

	CSV1100BP-3	CSV1300BP-3	CSV1600BP-3	CSV2000BP-3
Input				
Input Range	90-264 Vac	90-264 Vac	180-264 Vac	180-264 Vac
Frequency	47-63 Hz	47-63 Hz	47-63 Hz	47-63 Hz
Efficiency	94% Typ Platinum	94% Typ Platinum	94% Typ Platinum	94% Typ Platinum
EMI/RFI	Class A	Class A	Class A	Class A
Leakge Current	< 3.45 mA	< 3.45 mA	< 3.45 mA	< 3.45 mA
Outputs				
Output Main	12.2 V / 90.1 A	12 V / 106.6 A	12.2 V / 131.1 A	12.2 V / 163.9 A
Output Stand-by	12 V / 2.5 A	12 V / 3.0 A	12 V / 2.5 A	12 V / 2.5 A
OCP/OVP/OTP	YES	YES	YES	YES
I ² C Control	YES	YES	YES	YES
Environmental				
Operating Temp	0 °C to 50 °C	0 °C to 50 °C	0 °C to 50 °C	0 °C to 50 °C
Derating				
Storage	-40 °C to 70 °C	-40 °C to 60 °C	-40 °C to 70 °C	-40 °C to 70 °C
RoHS Compliant	YES	YES	YES	YES
MTBF	> 500K Hours	> 500K Hours	> 500K Hours	> 500K Hours
Other				
Size (inch)	1.57 x 3.15 x 7.73	1.57 x 3.15 x 7.73	1.57 x 3.15 x 7.73	1.57 x 3.15 x 7.73
Size (mm)	40 x 80 x 195	40 x 80 x 195	40 x 80 x 195	40 x 80 x 195
Power Density	28.8	34.0	41.8	52.3
Cubic Inches	38.22	38.22	38.22	38.22
Pro-E files	YES	YES	YES	YES
Thermal Data	YES	YES	YES	YES
PQ Airflow Curves	YES	YES	YES	YES
Warranty	Two years	Two years	Two years	Two years
Ordering Codes				
Standard	700-014189-1400	700-013496-J100	700-014190-1000	700-014265-1000
ALT Standby				
Reverse Air				
ALT Standby & Reverse Air				

PS1000 and PL1000

High Availability Power Supply Units

1000 Watts

Total Power: 1000 W
Output: 12.25 V



Special Features

- Fault mode resiliency
- AC feed failure, automatic switchover
- N+1 internal redundant
- Dynamic maximum input power limit (DMIPL)
- Inrush current control
- PMBus® compliant

Electrical Specifications

PS1000		
Output power	1000 W total	
Redundancy	680 W N+1 (3 x 340 W PSU modules in parallel)	
Output voltage	12.25 Vdc	
Phases	Dual three-phase AC input with input voltage selector (IVS)	
Efficiency	>92% at full load	
Input voltage	Three-phase 415/400 Vac Wye or 208 Vac Delta or Single-phase 200-240 Vac	
Operating temp	10 °C to 48 °C	
PL1000		
BBU	Embedded 8-cell, 32 V pack battery backup unit	
BBU specification	The battery shall operate for up to 1.0 second at 680 W. Then after that the PSU shall be capable to output 105 kJ between 100 W and 300 W. Typical run times are shown below:	
Power Level (W)	Runtime (s)	Energy (kJ)
100	1050	105
150	700	105
200	525	105
250	420	105
300	350	105
Operating temp	10 °C to 48 °C	

Compliance

EMC Conducted/Radiated Class A
EMC EN/IEC 61000
RoHS

Safety

UL/CSA 60950 (UL recognized)
IEC 60950
CE Mark

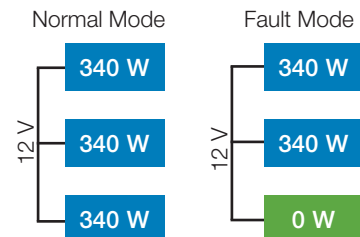

Mechanical Drawings

Front view



Rear view



Ordering Information

Model Number	Main Output	With Batteries
PL1000	12.25 V	Y
PS1000	12.25 V	N

PS1650

High Availability Power Supply Unit

1650 Watts

Total Power: 1650 W
Output: 12.25 V



Special Features

- Fault mode resiliency
- Dynamic maximum input power limit (DMIPL)
- Inrush current control
- N+1 internal and external redundancy, up to four (4) PSUs in a system
- PMBus® compliant
- Hot pluggable

Electrical Specifications

PS1650	
Output power	1650 W total
Redundancy	1100 W N+1 (3 x 550 W PSU modules in parallel) internal and external redundancy, supports up to four (4) PSUs in a system
Output voltage	12.25 Vdc
Efficiency	91%
Input voltage	Three-phase 415/400 Vac Wye or 208 Vac Delta or Single-phase 200-240 Vac
PSU operating temperature	10 °C to 45 °C

Compliance

- EMC Conducted/Radiated Class A
- EMC EN/IEC 61000
- RoHS

Safety

- UL/CSA 60950 (UL recognized)
- IEC 60950
- CE Mark

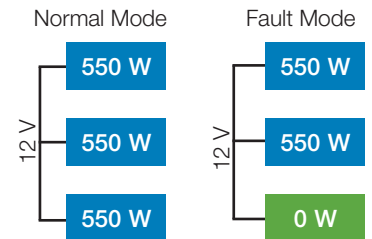

Mechanical Drawings

Front view



Rear view



Ordering Information

Model Number	Main Output
PS1650	12.25 V

12 V, 18kW 1U 19" and 21" Power Shelf

NEW!



18,000 Watts

Total Power: 18,000 W

Electrical Specifications

INPUT			
	MIN	NOM	MAX
Voltage (3P Delta 4W) VAC	180	200/240	264
Voltage (3P Wye 5W) VAC	342	380/480	528
Voltage (3x of 1P) VAC	180	200/277	305
OUTPUT			
	MIN	NOM	MAX
Set Point VDC	12.375	12.5	12.625
Regulation VDC	11.875	12.5	13.125
Current A	0	1440	1584
Ripple & Noise (@ 20MHz BW) mVpp			200
Output excursion (from nominal voltage) during transient loading mV			200
*Max Current Step: 60% of max load	-200		
*Dynamic Load: 50Hz / 50% Duty			
*Slew Rate: 2A/uS			
Current Sharing Error %			5
*From 20% to 100% loading			

Special Features

- 18000 W at 12.5 V with active current share
- Houses 6 x 3000 W power modules and a removable shelf controller
- Dual AC Inputs (Source-1 & Source-2)
- Accepts 3 types of input configurations (3P Delta 4 W, 3P Wye 5 W, 3 x of 1P)

Compliance

EN61000-4-5 Cat-B for surges
EN61000-3-2 Class-A for harmonics
EN55022, FCC Part 15, CISPR 22, Class-A for EMC

Safety

UL 60950
IEC 60950

12V, 3kW Dual Input PSU

NEW!



3,000 Watts

Total Power: 3,000 W

Special Features

- Greater than 96% efficiency @ 277 Vac for 50% loading
- Dual AC inputs (Source-1 & Source-2)
- 200 Vac to 277 Vac input
- With built-in source transfer switch
- Active current sharing
- OCP compliant
- Hot pluggable PSUs
- Status LEDs for fault monitoring

Electrical Specifications

INPUT			
	MIN	NOM	MAX
Voltage VAC	180	200/277	305
Hold up (@100% Load 200-277 VAC) msec		20	
iTHD (Load >20%) %			5
Power Factor (10% to 30% loading) %	90		
Power Factor (30% to 50% loading) %	96		
Power Factor (above 50% loading) %	98		
OUTPUT			
	MIN	NOM	MAX
Set Point VDC	12.375	12.5	12.625
Regulation VDC	11.875	12.5	13.125
Current A	0	240	264
Ripple & Noise (@ 20MHz BW) mVpp			200
Output excursion (from nominal voltage) during transient loading mV			200
*Max Current Step: 60% of max load	-200		
*Dynamic Load: 50Hz / 50% Duty			
*Slew Rate: 2A/uS			

ADN-C Series Single Phase

120-960 Watts

Special Features

- Slim form factor
- Five year warranty
- High efficiency > 90% typical
- Full power at 60 °C
- PowerBoost technology
- Industrial grade design
 - Metal mounting clip
 - Metal case
- MTBF > 450,000h demonstrated at 40 °C
- Active PFC > 0.92
- Adjustable output
- Overvoltage protection with auto recovery
- Continuous short-circuit and overload protection
- SEMI F47 Sag Immunity
- New visual diagnostic LED
- Three Status LEDs
 - Input, Output, Alarm
- DC OK Relay
- Parallel operation capability
- Screw terminal connections
- RoHS compliant
- No tools required for mounting



Electrical Specifications

Input	
AC Input range	Nominal: 115-230 Vac 85-264 Vac
DC Input range	90-375 Vdc
Frequency	47-67 Hz
Efficiency	> 90%
Inrush current	ADN5-24-1PM-C: < 15 A ADN10-24-1PM-C: < 30 A ADN20-24-1PM-C: < 40 A
PFC	Active, better than 0.92

Output	
Nominal voltage	ADN5-24-1PM-C & ADN10-24-1PM-C: 24 Vdc (22.5-28.5 Vdc Adj) ADN20-24-1PM-C: 24 Vdc (24-28 Vdc Adj)
Initial voltage setting	24.5 V ±1%
Hold-up time	> 20 ms at full load (100 Vac Input @ Tamb = +25 °C)
Voltage regulation	< ±2% (combination line, load, time and temperature related changes)
Ripple	ADN5-24-1PM-C & ADN10-24-1PM-C: < 50 mVpp ADN20-24-1PM-C: < 100 mVpp
Back EMF immunity	< 35 Vdc
PowerBoost	1.5x nominal current for 4 seconds
Short-circuit current	1.5x nominal current at near zero volts at short-circuit condition
Parallel operation	Switch selectable single unit or parallel unit operation. Units will not be damaged by parallel operation (regardless of switch position setting)
Output noise suppression	Radiated EMI values below EN61000-6-2
Overvoltage protection	> 30.5 Vdc but < 33 Vdc, auto recovery
Line and load regulation	< 0.5%
Time and temperature drift	< 1%



Power	Voltage	Current	Size L x W x H (mm)	Model Number
120 W	85-264 Vac 90-375 Vdc	5 A	4.85" x 1.97" x 4.37" (123 x 50 x 111)	ADN5-24-1PM-C
240 W	85-264 Vac 90-375 Vdc	10 A	4.85" x 2.36" x 4.37" (123 x 60 x 111)	ADN10-24-1PM-C
480 W	85-264 Vac 90-375 Vdc	20 A	4.85" x 3.42" x 4.96" (123 x 87 x 126)	ADN20-24-1PM-C
960 W	85-264 Vac 90-375 Vdc	40 A	4.81" x 7.09" x 4.85" (122.2 x 180 x 123.3)	ADN40-24-1PM-C

ADN-C Series 3-Phase

120-960 Watts



Special Features

- Slim form factor
- Five year warranty
- High efficiency > 93% typical
- Full power at 60 °C
- PowerBoost technology
- Industrial grade design – metal cases
- MTBF > 450,000h demonstrated at 40 °C
- Active PFC
- Adjustable output
- Overvoltage protection with auto recovery
- Continuous short-circuit and overload protection
- Three Status LEDs – Input, Output, Alarm
- DC OK Relay
- Parallel operation capability
- Screw terminal connections
- RoHS compliant
- No tools required for mounting

Electrical Specifications

Input

Nominal voltage	380-480 Vac
AC Input range	320-540 Vac
DC Input range	450-720 Vdc for ADN20
Frequency	50-60 Hz
Efficiency	93% for ADN20; 94% for ADN40
PFC	Active power factor correction
Two phase input	Derate to 75% and 50% for ADN20 and ADN40 respectively under loss of 1 phase. Units will shut down if thermal threshold is exceeded under this condition

Output

Nominal voltage	24 V (24.0-28.0 Vdc Adj.)
Hold-up time	> 20 ms for ADN20; > 15 ms for ADN40
Voltage regulation	< ±2% overall
Ripple	< 100 mVpp
PowerBoost	1.5x nominal current for 4 seconds
Peak current	1.5x nominal current for 4 seconds minimum while holding voltage > 20 Vdc
Parallel operation	Single or parallel operation selectable via front switch. For redundant operation use of external diode module is preferred; ADN40 uses active paralleling
Power back immunity	> 35 V
Overvoltage protection	> 30.5 Vdc but < 33 Vdc, auto recovery



Power	Voltage	Current	Size L x W x H (mm)	Model Number
120 W	320-540 Vac 450-760 Vdc	5 A @ 24 Vdc	4.85" x 1.97" x 4.37" (123 x 50 x 111)	ADN5-24-3PM-C
240 W	320-540 Vac 450-760 Vdc	10 A @ 24 Vdc	4.85" x 2.36" x 4.37" (123 x 60 x 111)	ADN10-24-3PM-C
480 W	320-540 Vac 450-760 Vdc	20 A @ 24 Vdc	4.68" x 3.34" x 4.85" (119 x 85 x 123)	ADN20-24-3PM-C
960 W	320-540 Vac	40 A @ 24 Vdc	4.85" x 7.09" x 4.85" (123 x 180 x 123)	ADN40-24-3PM-C



DC–DC Converters

Artesyn Embedded Power is widely acknowledged as an industry leader in distributed power applications and produces an exceptionally wide range of DC–DC conversion products.

Distributed Power Architecture

Artesyn Embedded Power understands the needs and nuances of developing power systems using Distributed Power Architecture. We know it is your job to create the most efficient, cost-effective, quality system, and deliver it in a timely fashion.

From full-system power to board-level components, high-power isolated front ends to a full line of isolated and non-isolated DC-DC modules, Artesyn Embedded Power is the source for today's power systems.

Distributed Power Architecture DC-DC Conversion

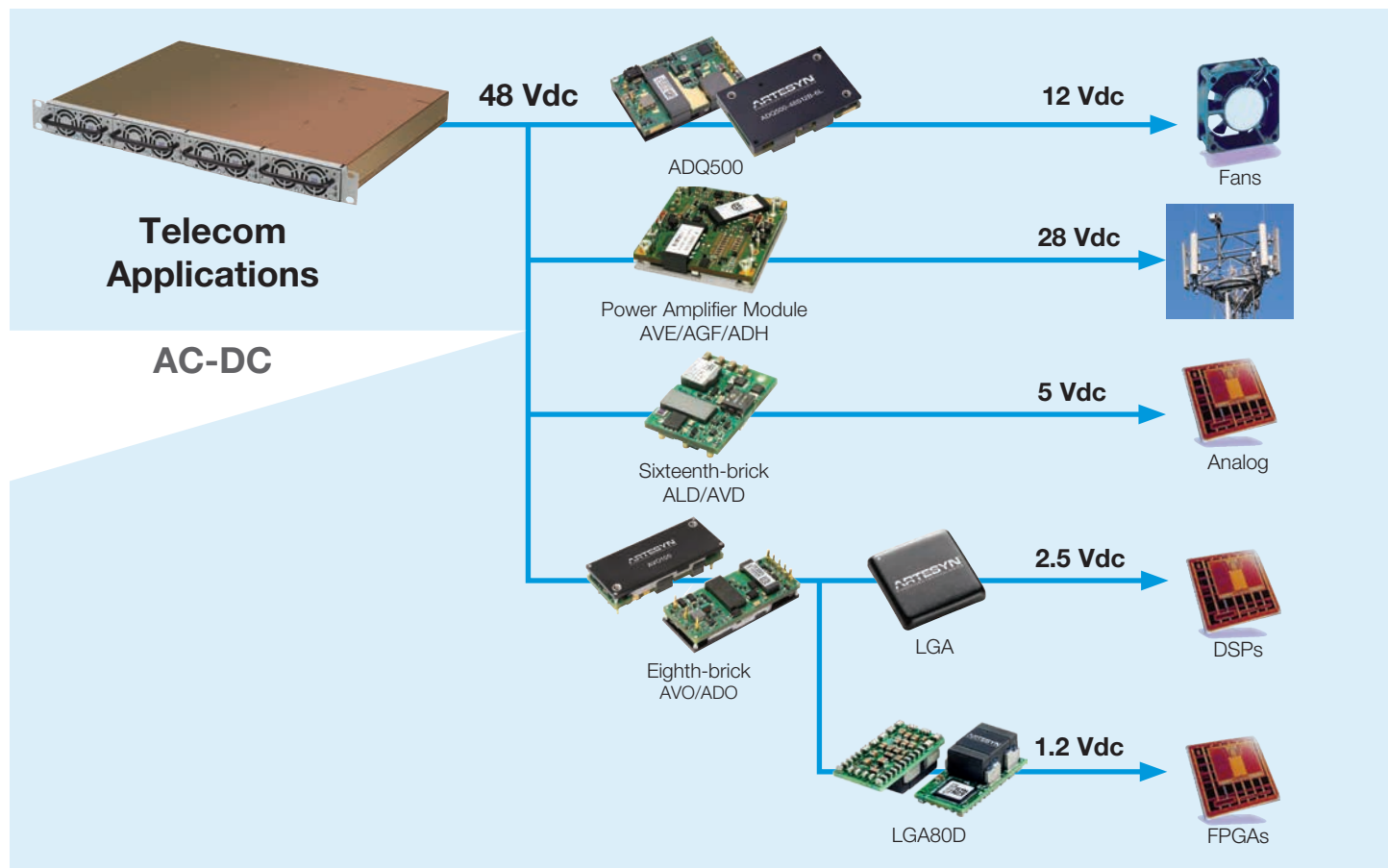
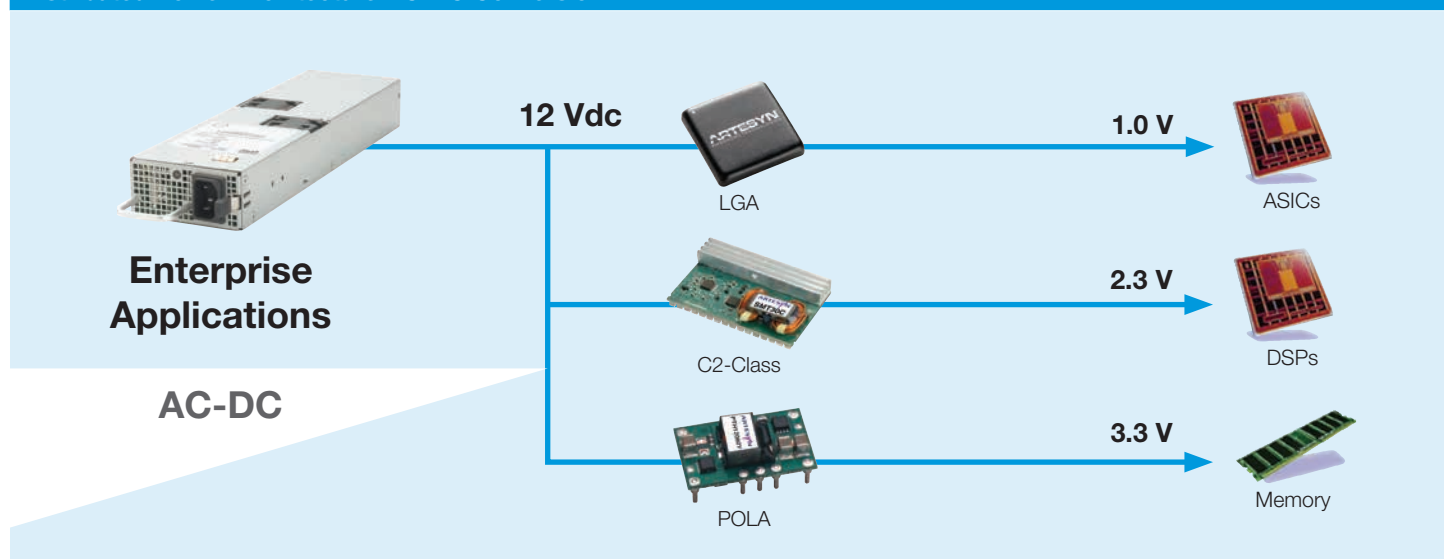

Sixteenth-Brick



AVD85



AVD120

Special Features

- Industry leading sixteenth-brick standard package and feature sets
- Scalable offering: 35 W, 50 W, 75 W, 85 W and 120 W platforms
- Mechanical options for optimum mounting flexibility: Through-hole (default) or surface mount (suffix “-S”) termination; 5 mm (default) or 3.7 mm through-hole pin length option
- Meets basic insulation
- Power densities as high as 146.5 W per cubic inch
- International safety standards approvals – UL, CSA, TÜV

V _{out}	I _{out}	Input Voltage	Package L x W x H (mm)	Efficiency	Model Number	
1.2 V	Open-frame					
	15 A	48 V (36-75 V)	1.3" x 0.9" x 0.35" (33 x 22.9 x 8.89)	84%	ALD15K48N-L	
	25 A	48 V (36-75 V)	1.3" x 0.9" x 0.34" (33 x 22.9 x 8.5)	84%	AVD75-48S1V2-6L	
	Baseplate					
	25 A	48 V (36-75 V)	1.3" x 0.9" x 0.5" (33 x 22.9 x 12.7)	84%	AVD75-48S1V2B-6L	
	3.3 V	Open-frame				
15 A		48 V (36-75 V)	1.3" x 0.9" x 0.37" (33 x 22.9 x 9.5)	91%	AVD50B-48S3V3-6L	
20 A		48 V (36-75 V)	1.3" x 0.9" x 0.39" (33 x 22.9 x 10)	92%	AVD75-48S3V3-6L	
23 A		48 V (36-75 V)	1.3" x 0.9" x 0.36" (33 x 22.9 x 9.2)	91.5%	AVD75B-48S3V3-6L	
25 A		48 V (36-75 V)	1.3" x 0.9" x 0.39" (33 x 22.9 x 10)	92%	AVD85-48S3V3-6L	
Baseplate						
15 A		48 V (36-75 V)	1.3" x 0.9" x 0.47" (33 x 22.9 x 12)	92%	AVD50B-48S3V3B-6L	
20 A		48 V (36-75 V)	1.3" x 0.9" x 0.5" (33 x 22.9 x 12.7)	92%	AVD75-48S3V3B-6L	
23 A		48 V (36-75 V)	1.3" x 0.9" x 0.47" (33 x 22.9 x 12)	91.5%	AVD75B-48S3V3B-6L	
25 A		48 V (36-75 V)	1.3" x 0.9" x 0.5" (33 x 22.9 x 12.7)	92%	AVD85-48S3V3B-6L	
SMT pin with reel tape package						
15 A		48 V (36-75 V)	1.3" x 0.9" x 0.37" (33 x 22.9 x 9.4)	92%	AVD50B-48S3V3TL	
23 A		48 V (36-75 V)	1.3" x 0.9" x 0.37" (33 x 22.9 x 9.4)	91.5%	AVD75B-48S3V3TL	
5 V		Open-frame				
		7 A	48 V (36-75 V)	1.3" x 0.9" x 0.35" (33 x 22.9 x 8.89)	91%	ALD07A48N-L
	10 A	48 V (36-75 V)	1.3" x 0.9" x 0.36" (33 x 22.9 x 9.2)	91.5%	AVD50B-48S05-6L	
	10 A	48 V (36-75 V)	1.3" x 0.9" x 0.37" (33 x 22.9 x 9.5)	92%	AVD50-48S05-6L	
	15 A	48 V (36-75 V)	1.3" x 0.9" x 0.36" (33 x 22.9 x 9.2)	91.5%	AVD75B-48S05-6L	
	17 A	48 V (36-75 V)	1.3" x 0.9" x 0.36" (33 x 22.9 x 9.2)	91.5%	AVD85B-48S05-6L	
	17 A	48 V (36-75 V)	1.3" x 0.9" x 0.39" (33 x 22.9 x 10)	92%	AVD85-48S05-6L	
	20 A	48 V (36-75 V)	1.3" x 0.9" x 0.39" (33 x 22.9 x 10)	92%	AVD100-48S05-6L	
	Baseplate					
	10 A	48 V (36-75 V)	1.3" x 0.9" x 0.47" (33 x 22.9 x 12)	91.5%	AVD50B-48S05B-6L	
	15 A	48 V (36-75 V)	1.3" x 0.9" x 0.47" (33 x 22.9 x 12)	91.5%	AVD75B-48S05B-6L	
	17 A	48 V (36-75 V)	1.3" x 0.9" x 0.47" (33 x 22.9 x 12)	91.5%	AVD85B-48S05B-6L	
	17 A	48 V (36-75 V)	1.3" x 0.9" x 0.5" (33 x 22.9 x 12.7)	92%	AVD85-48S05B-6L	
	20 A	48 V (36-75 V)	1.3" x 0.9" x 0.5" (33 x 22.9 x 12.7)	92%	AVD100-48S05B-6L	
	SMT pin with reel tape package					
	10 A	48 V (36-75 V)	1.3" x 0.9" x 0.37" (33 x 22.9 x 9.4)	91.5%	AVD50B-48S05TL	
	15 A	48 V (36-75 V)	1.3" x 0.9" x 0.37" (33 x 22.9 x 9.4)	91.5%	AVD75B-48S05TL	
	17 A	48 V (36-75 V)	1.3" x 0.9" x 0.37" (33 x 22.9 x 9.4)	91.5%	AVD85B-48S05TL	

Vout	Iout	Input Voltage	Package L x W x H (mm)	Efficiency	Model Number
12 V	Open-frame				
	2.75 A	48 V (36-75 V)	1.3" x 0.9" x 0.35" (33 x 22.9 x 8.89)	92%	ALD03B48N-L
	4.17 A	48 V (36-75 V)	1.3" x 0.9" x 0.36" (33 x 22.9 x 9.2)	93%	AVD50B-48S12-6L
	6.25 A	48 V (36-75 V)	1.3" x 0.9" x 0.36" (33 x 22.9 x 9.2)	93.3%	AVD75B-48S12-6L
	7 A	48 V (36-75 V)	1.3" x 0.9" x 0.39" (33 x 22.9 x 10)	92%	AVD85-48S12-6L
	7.1 A	48 V (36-75 V)	1.3" x 0.9" x 0.36" (33 x 22.9 x 9.2)	93.3%	AVD85B-48S12-6L
	10 A	48 V (36-75 V)	1.3" x 0.9" x 0.39" (33 x 22.9 x 10)	92%	AVD120-48S12-6L
	Baseplate				
	4.17 A	48 V (36-75 V)	1.3" x 0.9" x 0.47" (33 x 22.9 x 12)	93%	AVD50B-48S12B-6L
	6.25 A	48 V (36-75 V)	1.3" x 0.9" x 0.47" (33 x 22.9 x 12)	93.3%	AVD75B-48S12B-6L
	7 A	48 V (36-75 V)	1.3" x 0.9" x 0.5" (33 x 22.9 x 12.7)	92%	AVD85-48S12B-6L
	7.1 A	48 V (36-75 V)	1.3" x 0.9" x 0.47" (33 x 22.9 x 12)	93.3%	AVD85B-48S12B-6L
	10 A	48 V (36-75 V)	1.3" x 0.9" x 0.5" (33 x 22.9 x 12.7)	92%	AVD120-48S12B-6L
	SMT pin with reel tape package				
	4.17 A	48 V (36-75 V)	1.3" x 0.9" x 0.37" (33 x 22.9 x 9.4)	93%	AVD50B-48S12TL
	6.25 A	48 V (36-75 V)	1.3" x 0.9" x 0.37" (33 x 22.9 x 9.4)	93.3%	AVD75B-48S12TL
	7.1 A	48 V (36-75 V)	1.3" x 0.9" x 0.37" (33 x 22.9 x 9.4)	93.3%	AVD85B-48S12TL

Eighth-Brick



Special Features

- Industry leading eighth-brick standard package and feature sets
- Scalable output power offering: Low power 80 W series or up to 300 W high power series
- Mechanical options for optimum mounting flexibility: Open-frame (ALO, LES, AVO) or baseplate (AEO or AVO-B) construction; Through-hole (default) or surface mount (suffix "-S") termination; 5 mm (default) or 3.7 mm through-hole pin length option
- PMBus interface
- Meets basic insulation
- Power densities as high as 181 W per cubic inch
- Wide operating temperature range
- International safety standards approvals – UL, CSA, TÜV

Vout	Iout	Input Voltage	Package L x W x H (mm)	Efficiency	Model Number
1.2 V	Open-frame				
	20 A	48 V (36-75 V)	2.3" x 0.9" x 0.38" (57.9 x 22.9 x 9.6)	86%	AVO50-48S1V2-4
	25 A	48 V (36-75 V)	2.3" x 0.9" x 0.38" (57.9 x 22.9 x 9.6)	86%	AVO75-48S1V2-4
3.3 V	Baseplate				
	50 A	48 V (36-75 V)	2.3" x 0.9" x 0.5" (57.9 x 22.9 x 12.7)	85.5%	AVO100-48S1V2B-6L
3.3 V	Open-frame				
	15 A	48 V (36-75 V)	2.3" x 0.9" x 0.38" (57.9 x 22.9 x 9.6)	90%	AVO50C-48S3V3-6
	20 A	24 V/48 V (19-60 V)	2.3" x 0.9" x 0.32" (57.9 x 22.9 x 8.13)	91%	ALO20F36N-L
	20 A	48 V (36-75 V)	2.3" x 0.9" x 0.38" (57.9 x 22.9 x 9.6)	91%	AVO75-48S3V3-4
	30 A	48 V (36-75 V)	2.3" x 0.9" x 0.38" (57.9 x 22.9 x 9.6)	91%	AVO100B-48S3V3-6L
	60 A	48 V (36-75 V)	2.3" x 0.9" x 0.44" (58.4 x 22.9 x 11.2)	93.5%	ADO300-48S3V3-6L
	60 A	48 V (36-75 V)	2.3" x 0.9" x 0.44" (58.4 x 22.9 x 11.2)	93.5%	ADO300-48S3V3-6LI
	Baseplate				
	30 A	48 V (36-75 V)	2.3" x 0.9" x 0.4" (57.9 x 22.9 x 10.16)	91%	AVO100C-48S3V3B-4L
	60 A	48 V (36-75 V)	2.3" x 0.9" x 0.53" (58.4 x 22.9 x 13.5)	93.5%	ADO300-48S3V3B-6L
	60 A	48 V (36-75 V)	2.3" x 0.9" x 0.53" (58.4 x 22.9 x 13.5)	93.5%	ADO300-48S3V3B-6LI

Vout	Iout	Input Voltage	Package L x W x H (mm)	Efficiency	Model Number
5 V	Open-frame				
	10 A	48 V (36-75 V)	2.3" x 0.9" x 0.38" (57.9 x 22.9 x 9.6)	91%	AVO50-48S05-4
	15 A	48 V (36-75 V)	2.3" x 0.9" x 0.38" (57.9 x 22.9 x 9.6)	91%	AVO75-48S05-6
	20 A	48 V (36-75 V)	2.3" x 0.9" x 0.38" (57.9 x 22.9 x 9.6)	92.8%	AVO100-48S05-6L
	40 A	48 V (36-75 V)	2.3" x 0.9" x 0.38" (57.9 x 22.9 x 9.6)	94%	AVO200-48S05-6L
	60 A	48 V (36-75 V)	2.3" x 0.9" x 0.44" (58.4 x 22.9 x 11.2)	95%	ADO300-48S05-6L
	60 A	48 V (36-75 V)	2.3" x 0.9" x 0.44" (58.4 x 22.9 x 11.2)	95%	ADO300-48S05-6LI
	Baseplate				
	20 A	48 V (36-75 V)	2.3" x 0.9" x 0.5" (57.9 x 22.9 x 12.7)	92.8%	AVO100-48S05B-6L
	40 A	48 V (36-75 V)	2.3" x 0.9" x 0.5" (57.9 x 22.9 x 12.7)	94%	AVO200-48S05B-6L
	60 A	48 V (36-75 V)	2.3" x 0.9" x 0.53" (58.4 x 22.9 x 13.5)	95%	ADO300-48S05B-6L
	60 A	48 V (36-75 V)	2.3" x 0.9" x 0.53" (58.4 x 22.9 x 13.5)	95%	ADO300-48S05B-6LI
	60 A	48 V (36-75 V)	2.3" x 0.9" x 0.53" (58.4 x 22.9 x 13.5)	95%	ADO300-48S05PB-6L
	10.1 V	Baseplate			
50 A		48 V (45-56 V)	2.3" x 0.91" x 0.48" (58.4 x 23.2 x 12.2)	96.5%	ADO500-48S10-4L
55 A		48 V (45-56 V)	2.3" x 0.91" x 0.57" (58.4 x 23.2 x 14.5)	96.5%	ADO550-48S10B-4L
12 V	Open-frame				
	4.2 A	48 V (36-75 V)	2.3" x 0.9" x 0.38" (57.9 x 22.9 x 9.6)	91%	AVO50-48S12-6L
	6.3 A	48 V (36-75 V)	2.3" x 0.9" x 0.38" (57.9 x 22.9 x 9.6)	91%	AVO75-48S12P-4
	10 A	48 V (36-75 V)	2.3" x 0.9" x 0.38" (57.9 x 22.9 x 9.6)	93%	AVO120-48S12-6L
	17 A	48 V (36-75 V)	2.3" x 0.9" x 0.38" (57.9 x 22.9 x 9.6)	94%	AVO200-48S12-6L
	20 A	48 V (41-75 V)	2.3" x 0.9" x 0.38" (57.9 x 22.9 x 9.6)	94%	AVO240-48S12-6L
	26 A	48 V (36-75 V)	2.3" x 0.9" x 0.44" (57.9 x 22.9 x 11.2)	95%	ADO300-48S12-6L
	26 A	48 V (36-75 V)	2.3" x 0.9" x 0.44" (57.9 x 22.9 x 11.2)	95%	ADO300-48S12-6LI
	Baseplate				
	4 A	48 V (36-75 V)	2.3" x 0.9" x 0.4" (57.9 x 22.9 x 10.16)	93%	AEO04B48N-L
	10 A	48 V (36-75 V)	2.3" x 0.9" x 0.5" (57.9 x 22.9 x 12.7)	93%	AVO120-48S12B-6L
	17 A	48 V (36-75 V)	2.3" x 0.9" x 0.5" (57.9 x 22.9 x 12.7)	94%	AVO200-48S12B-6L
	20 A	48 V (41-75 V)	2.3" x 0.9" x 0.5" (57.9 x 22.9 x 12.7)	94%	AVO240-48S12B-6L
	26 A	48 V (36-75 V)	2.3" x 0.9" x 0.53" (57.9 x 22.9 x 13.5)	95%	ADO300-48S12B-6L
	26 A	48 V (36-75 V)	2.3" x 0.9" x 0.53" (57.9 x 22.9 x 13.5)	95%	ADO300-48S12B-6LI



Quarter-Brick



Special Features

- Industry leading quarter-brick standard package and feature sets
- Up to 100 A offering
- Wide operating temperature range
- Meets basic insulation
- PMBus interface
- Exceptional dynamic response and reactive loading capability
- Monotonic start-up characteristic
- International safety standards approvals – UL, CSA, TÜV

Vout	Iout	Input Voltage	Package L x W x H (mm)	Efficiency	Model Number
3.3 V	Open-frame				
	40 A	48 V (36-75 V)	2.28" x 1.45" x 0.39" (57.9 x 36.8 x 9.8)	91%	AGQ200B-48S3V3-4L
	Baseplate				
	40 A	48 V (36-75 V)	2.28" x 1.45" x 0.50" (57.9 x 36.8 x 12.7)	91%	AGQ200B-48S3V3B-4L
5 V	Open-frame				
	20 A	24 V (18-36 V)	2.28" x 1.45" x 0.39" (57.9 x 36.8 x 9.8)	91%	AVQ100-24S05-4L
	Baseplate				
	20 A	24 V (18-36 V)	2.28" x 1.45" x 0.50" (57.9 x 36.8 x 12.7)	91%	AVQ100-24S05B-4L
10 V	Open-frame				
	60 A	48 V (40-60 V)	2.28" x 1.45" x 0.43" (57.9 x 36.8 x 11)	95%	ADQ600-48S10-6L
	Baseplate				
	60 A	48 V (40-60 V)	2.28" x 1.45" x 0.52" (57.9 x 36.8 x 13.3)	95%	ADQ600-48S10B-6L
12 V	Open-frame				
	25 A	48 V (36-75 V)	2.28" x 1.45" x 0.36" (57.9 x 36.8 x 9.6)	94%	AVQ300-48S12-6L
	33 A	48 V (36-75 V)	2.28" x 1.45" x 0.36" (57.9 x 36.8 x 9.6)	93%	AVQ400-48S12-6L
	42 A	48 V (36-75 V)	2.28" x 1.45" x 0.43" (57.9 x 36.8 x 11)	95%	ADQ500-48S12-6L
	50 A	48 V (40-60 V)	2.28" x 1.45" x 0.43" (57.9 x 36.8 x 11)	95%	ADQ600-48S12-6L
	58 A	48 V (40-60 V)	2.3" x 1.4" x 0.43" (58.4 x 36.8 x 11)	96%	ADQ700-48S12-4L
	58 A	48 V (40-60 V)	2.3" x 1.4" x 0.43" (58.4 x 36.8 x 11)	96%	ADQ700-48S12-4LI
	Baseplate				
	25 A	48 V (36-75 V)	2.28" x 1.45" x 0.50" (57.9 x 36.8 x 12.7)	94%	AVQ300-48S12B-4L
	33 A	48 V (36-75 V)	2.28" x 1.45" x 0.50" (57.9 x 36.8 x 12.7)	93%	AVQ400-48S12B-6L
	42 A	48 V (36-75 V)	2.28" x 1.45" x 0.43" (57.9 x 36.8 x 11)	95%	ADQ500-48S12B-6L
	50 A	48 V (40-60 V)	2.28" x 1.45" x 0.52" (57.9 x 36.8 x 13.3)	95%	ADQ600-48S12B-6L
	58 A	48 V (40-60 V)	2.3" x 1.4" x 0.52" (58.4 x 36.8 x 13.6)	96%	ADQ700-48S12B-4L
	58 A	48 V (40-60 V)	2.3" x 1.4" x 0.52" (58.4 x 36.8 x 13.6)	96%	ADQ700-48S12B-4LI
70 A	48 V (40-60 V)	2.3" x 1.4" x 0.53" (58.4 x 36.8 x 13.6)	96%	ADQ800-48S12B-4L	
NEW! 90 A	48 V (40-60 V)	2.3" x 1.4" x 0.57" (58.4 x 36.8 x 14.5)	97.7%	BCQ1300-48S12B-4L	
NEW! 90 A	48 V (40-60 V)	2.3" x 1.4" x 0.57" (58.4 x 36.8 x 14.5)	97.5%	BDQ1300-48S12B-4L	
NEW! 90 A	48 V (40-60 V)	2.3" x 1.4" x 0.57" (58.4 x 36.8 x 14.5)	97.5%	BDQ1300-48S12B-4LI	

RF Power Bricks



Special Features

- Specialized high power bricks for RF applications such as base station power amplifiers
- Offered in 24 V and 48 V input voltages
- Wide output voltage adjustability
- -40 °C to 85 °C for AVE, AGF baseplate temperature with no derating at rated power
- International safety standard approvals – UL, CSA, VDE, CB Report

Eight-Brick

Vout	Iout	Input Voltage	Package L x W x H (mm)	Efficiency	Model Number
28 V	Open-Frame				
	3.57 A	48 V (36-75 V)	2.3" x 0.9" x 0.39" (57.9 x 22.9 x 9.6)	92%	AVO100-48S28-6L
	Baseplate				
	3.57 A	48 V (36-75 V)	2.3" x 0.9" x 0.5" (57.9 x 22.9 x 12.7)	92%	AVO100-48S28B-6L
	9 A	48 V (36-75 V)	2.3" x 0.9" x 0.5" (57.9 x 22.9 x 12.7)	93%	AVO250-48S28B-6L

Quarter-Brick

Vout	Iout	Input Voltage	Package L x W x H (mm)	Efficiency	Model Number
NEW! 50 V	Baseplate				
	10 A	48 V (36-75 V)	2.28" x 1.45" x 0.5" (57.9 x 36.8 x 12.7)	94%	AGQ500-48S50-6L
	10 A	48 V (36-75 V)	2.28" x 1.45" x 0.5" (57.9 x 36.8 x 12.7)	94%	AGQ500-48S50P-6L

Half-Brick

Vout	Iout	Input Voltage	Package L x W x H (mm)	Efficiency	Model Number
28 V	Aluminum Substrate				
	12.5 A	24 V (18-36 V)	2.4" x 2.3" x 0.5" (61 x 57.9 x 12.7)	93%	AVE350-24S28-6L
	12.5 A	48 V (36-75 V)	2.4" x 2.3" x 0.5" (61 x 57.9 x 12.7)	93%	AVE350B-48S28-6
	16 A	48 V (36-75 V)	2.4" x 2.3" x 0.5" (61 x 57.9 x 12.7)	94%	AVE450B-48S28-6L/M
	25 A	48 V (36-65 V)	2.3" x 2.4" x 0.5" (57.9 x 61 x 12.7)	95%	ADH700-48S28-6L
	25 A	48 V (36-65 V)	2.3" x 2.4" x 0.5" (57.9 x 61 x 12.7)	95%	ADH700-48S28P-6L
50 V	9 A	48 V (36-75 V)	2.3" x 2.4" x 0.5" (57.9 x 61 x 12.7)	95%	AVE450-48S50-6L
	9 A	48 V (36-75 V)	2.3" x 2.4" x 0.5" (57.9 x 61 x 12.7)	95%	AVE450-48S50P-6L
	10 A	48 V (36-75 V)	2.3" x 2.4" x 0.5" (57.9 x 61 x 12.7)	95%	AVE500-48S50-6L
	10 A	48 V (36-75 V)	2.3" x 2.4" x 0.5" (57.9 x 61 x 12.7)	95%	AVE500-48S50P-6L
	14 A	48 V (36-65 V)	2.3" x 2.4" x 0.5" (57.9 x 61 x 12.7)	95%	ADH700-48S50-6L
	14 A	48 V (36-65 V)	2.3" x 2.4" x 0.5" (57.9 x 61 x 12.7)	95%	ADH700-48S50P-6L

Full-Brick

Vout	Iout	Input Voltage	Package L x W x H (mm)	Efficiency	Model Number
14-33 V	Aluminum Substrate				
	21.5 A	24 V (18-36 V)	4.6" x 2.4" x 0.5" (116.8 x 61 x 12.7)	93%	AGF600-24S28-6L
	21.5 A	48 V (36-75 V)	4.6" x 2.4" x 0.5" (116.8 x 61 x 12.7)	93.5%	AGF600-48S28-6L
	25 A	48 V (36-75 V)	4.6" x 2.4" x 0.5" (116.8 x 61 x 12.7)	93%	AGF700-48S30LT
	28.5 A	48 V (36-75 V)	4.6" x 2.4" x 0.5" (116.8 x 61 x 12.7)	94%	AGF800-48S28-6L
48 V	16 A	50 V (36-75 V)	4.6" x 2.4" x 0.5" (116.8 x 61 x 12.7)	94.5%	AGF800-48S48P-6L
	30 V/5 V	23.3 A / 20 A	48 V (36-75 V)	4.6" x 2.4" x 0.5" (116.8 x 61 x 12.7)	93.5%

Wide Input Voltage Series



Special Features

- Wide input voltage range to cover 24 V and 48 V input
- Industry standard brick package
- Open-frame and baseplate construction
- Wide operating temperature

	Vout	Iout	Input Voltage	Efficiency	Package LxWxH (mm)	Model number
Quarter Brick Baseplate	3.3 V	25 A	24 V, 48 V (18-60 V)	90% @ 48 vin, 92% @ 24 vin	2.28" x 1.45" x 0.40" (57.9 x 36.8 x 10.2)	AVQ100-36S3V3B-6L
Quarter Brick Baseplate	12 V	19 A	24 V, 48 V (18-75 V)	94%	2.28" x 1.45" x 0.50" (57.9 x 36.8 x 12.7)	AVQ200-36S12B-6L
Quarter Brick Open-frame	3.3 V	25 A	24 V, 48 V (18-60 V)	90% @ 48 vin, 92% @ 24 vin	2.28" x 1.45" x 0.40" (57.9 x 36.8 x 10.2)	AVQ100-36S3V3-6L
Quarter Brick Open-frame	12 V	19 A	24 V, 48 V (18-75 V)	94%	2.28" x 1.45" x 0.38" (57.9 x 36.8 x 9.6)	AVQ200-36S12-6L

Direct Conversion - Power Stamp Alliance Series

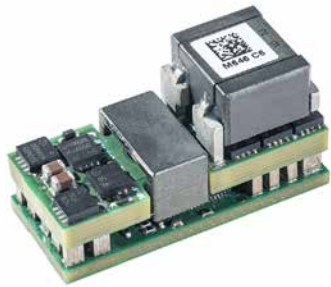

ADC100M

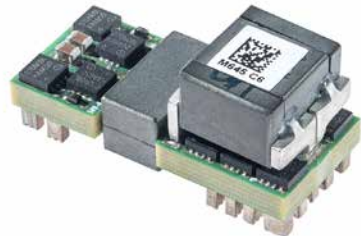

ADC100S

Special Features

- 100 A TDC current
- PSA compliant
- Up to 93% efficient
- Low ripple and noise
- Data center 48 Vdc input range
- Open frame optimized for air cooling
- Surface mount termination
- Fixed switching frequency
- High capacitive load capability
- Pre-bias startup capability
- High reliability
- RoHS 6 compliant
- UL94 V-0 materials

	Output Current	Input Voltage	Output Voltage	Efficiency	Package L x W x H (mm)	Model Number
NEW!	100 A	40-60 Vdc	1.6-2.0 V	92%	1.18" x 0.5" x 0.67" (30 x 12.7 x 17)	ADC100M-04Y
NEW!	100 A	40-60 Vdc	1.6-2.0 V	92%	1.18" x 0.5" x 0.59" (30 x 12.7 x 15)	ADC100S-04Y

C-Class – High Density

The 2nd generation C-Class non-isolated DC–DC converters are designed to provide good efficiency and performance, a smaller footprint, and integrated input and output capacitors.



Special Features

- Wide input voltage ranges: 3-13.8 V or 4.5-13.8 V
- Wide output voltage trim/adjustability: 0.59-5.1 V
- Output current: 3-40 A
- High efficiency up to 94%
- Remote sense (Sxx20C2, Sxx40C2 and Sxx60C2)
- Operating temperature range for LDO03, LDO06, LDO10: -40 °C to 85 °C.
- Operating temperature range for SIL/SMT20C2, SIL/SMT40C2 and SIL60C2: 0 °C to 70 °C
- Cost-optimized design – industry leading value
- Compact footprint, vertical, horizontal and horizontal SMT options
- International safety standard approvals – UL, CSA, TÜV & CB Report

General-Purpose C-Class Non-Isolated DC–DC Converters

Output Current	Input Voltage	Output Voltage	Efficiency	Package L x W x H (mm)	Model Number
Single-In-Line, Through-Hole Mounting					
3 A	3.0-13.8 Vdc	0.59-5.1 V	90%	0.37" x 0.21" x 0.61" (9.4 x 5.33 x 15.49)	LDO03C-005W05-VJ
6 A	3.0-13.8 Vdc	0.59-5.1 V	92%	0.41" x 0.37" x 0.65" (10.41 x 9.4 x 16.51)	LDO06C-005W05-VJ
10 A	3.0-13.8 Vdc	0.59-5.1 V	94%	0.41" x 0.45" x 0.65" (10.41 x 11.43 x 16.51)	LDO10C-005W05-VJ
20 A	4.5-13.8 Vdc	0.59-5.1 V	93%	1.2" x 0.46" x 0.61" (30.48 x 11.68 x 15.49)	SIL20C2-00SADJ-VJ
40 A	4.5-13.8 Vdc	0.6-5.0 V	94%	1.2" x 0.43" x 1.1" (30.48 x 10.92 x 27.94)	SIL40C2-00SADJ-VJ
60 A	10.8-13.2 Vdc	1.2-4.0 V	89%	1.98" x 0.54" x 0.78" (50.29 x 13.72 x 19.81)	SIL60C2-00SADJ-VDJ
Surface-Mounting					
3 A	3.0-13.8 Vdc	0.59-5.1 V	90%	0.61" x 0.37" x 0.29" (15.49 x 9.4 x 7.37)	LDO03C-005W05-SJ
6 A	3.0-13.8 Vdc	0.59-5.1 V	92%	0.65" x 0.41" x 0.44" (16.51 x 10.41 x 11.18)	LDO06C-005W05-SJ
10 A	3.0-13.8 Vdc	0.59-5.1 V	94%	0.65" x 0.41" x 0.52" (16.51 x 10.41 x 13.21)	LDO10C-005W05-SJ
20 A	4.5-13.8 Vdc	0.59-5.1 V	93%	1.2" x 0.61" x 0.48" (30.48 x 15.49 x 12.19)	SMT20C2-00SADJJ
40 A	4.5-13.8 Vdc	0.6-5.0 V	94%	1.2" x 1.1" x 0.44" (30.48 x 27.94 x 11.18)	SMT40C2-00SADJJ





LGA Series

Dual Output Non-isolated Digital DC-DC Converter

Special Features

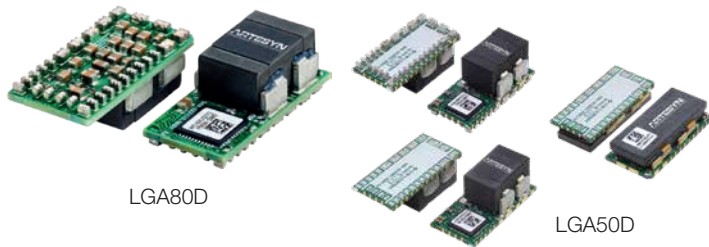

- Two-phase design
- Dual or single output configuration possible
- High efficiency up to 95.5%
- Small size 1" x 0.5" x 0.48" (L x W x H)
- Support PMBus
- No minimum load requirement
- Wide operating temperature range
- Exceptional power density
- Automatic loop compensation
- Excellent transient response
- Analog or digital control
- IPC9592B compliant
- Tape and reel packaging
- Reflow compatible
- Can stack up to 8 phases, with an output of 320 A
- Two year warranty
- Evaluation kit is available

	Output Current	Input Voltage	Output Voltage	Efficiency	Package L x W x H (mm)	Model Number
NEW!	Total Output: 50 A	7.5-14 Vdc	0.6-3.3 Vdc	95.5%	1" x 0.5" x 0.48" (25.4 x 12.7 x 5.85)	LGA50D-01DADJ
	Channel 1: 25 A	7.5-14 Vdc	0.6-5 Vdc	95.5%	1" x 0.5" x 0.48" (25.4 x 12.7 x 12.2)	LGA50D-01DADJ
	Channel 2: 25 A	7.5-14 Vdc	0.6-5 Vdc	95.5%	1" x 0.5" x 0.48" (25.4 x 12.7 x 10.6)	LGA50D-01DADJ
	Total Output: 80 A	7.5-14 Vdc	0.6-5 Vdc	95.5%	1" x 0.5" x 0.48" (25.4 x 12.7 x 12.2)	LGA80D-00DADJJ
	Channel 1: 40 A	7.5-14 Vdc	0.6-5 Vdc	95.5%	1" x 0.5" x 0.48" (25.4 x 12.7 x 12.2)	LGA80D-00DADJJ
	Channel 2: 40 A	7.5-14 Vdc	0.6-5 Vdc	95.5%	1" x 0.5" x 0.48" (25.4 x 12.7 x 12.2)	LGA80D-00DADJJ

C-Class – High Density LGA C Series

The latest addition to the C-Class non-isolated DC-DC converter offering packaged in an ultra-compact, low-profile Land Grid Array with current densities up to 225 A/in³.

Special Features

- High density, ultra low profile surface mount module in Land Grid Array (LGA) package
- Available in 4 different output current levels: 3, 6, 10 and 20 Amps
- Wide input voltage range: 3.0-14.0 V
- Adjustable output voltage: 0.59-5.1 V via external resistor
- High efficiency ~92% typical
- Wide ambient operating temperature range: -40 °C to 85 °C
- Input UVLO; Remote On/Off; Output Adjust; Margin; PGood signal, Differential sense
- Current sink capability for voltage termination applications
- Integrated input and output capacitors resulting in minimal external capacitance required for stable operation



LGA C Series Non-Isolated DC-DC Converters

	Output Current	Input Voltage	Output Voltage	Efficiency	Package L x W x H (mm)	Model Number
Surface-Mounting						
	3 A	3.0-14 Vdc	0.59-5.1 V	92%	0.65" x 0.65" x 0.129" (16.51 x 16.51 x 3.27)	LGA03C-00SADJJ
	6 A	3.0-14 Vdc	0.59-5.1 V	92%	0.65" x 0.65" x 0.129" (16.51 x 16.51 x 3.27)	LGA06C-00SADJJ
	10 A	3.0-14 Vdc	0.59-5.1 V	92%	0.65" x 0.65" x 0.129" (16.51 x 16.51 x 3.27)	LGA10C-00SADJJ
	20 A	4.5-14 Vdc	0.59-5.1 V	91%	0.65" x 0.65" x 0.210" (16.51 x 16.51 x 5.33)	LGA20C-01SADJJ

Note: Optional heatsink kits are available. Ordering part number is LGA-HTSK-KIT-XXX

XXX = Total height of the LGA20C-01SADJJ with heatsink attached: 045 = 0.45"; 048 = 0.48"; 050 = 0.50"

E-Class – Performance

Efficiencies as high as 96% and current densities up to 140 A/in³.

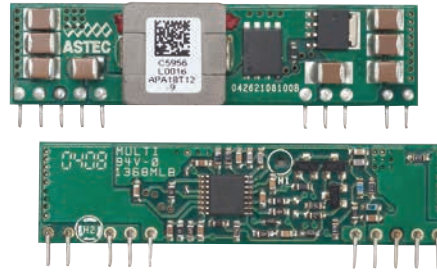
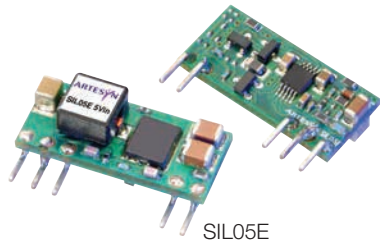

Special Features

Efficiencies as high as 96% and current densities up to 140 A/in³.

- Input voltage ranges: 3-5.5 V, 4.5-5.5 V, 8-14 V, 10-14 V
- Wide output voltage trim ranges: 0.8-3.63 V and 0.75-5.5 V
- Output current: 5-30 A
- Remote on/off
- Remote sense
- Industry standard footprint—vertical and horizontal mounting (low profile SMT/SIP—through-hole)
- Operating temperature range: -40 °C to 85 °C
- Protection: overcurrent/short-circuit
- International safety standard approvals –UL, CSA, TÜV & CB Report

General-Purpose E-Class Non-Isolated DC–DC Converters

Output Current	Input Voltage	Output Voltage	Efficiency	Package L x W x H (mm)	Model Number
Single-In-Line, Through-hole Mounting					
5 A	3.0-5.5 Vdc	0.75-3.63 V	94%	0.9" x 0.28" x 0.4" (22.86 x 7.11 x 10.16)	SIL05E-05W3V3-VJ
10 A	4.5-5.5 Vdc	0.8-3.63 V	95%	2" x 0.31" x 0.5" (50.8 x 7.87 x 12.7)	SIL10E-05W3V3-VJ
10 A	10-14 Vdc	0.8-3.63 V	94%	2" x 0.31" x 0.5" (50.8 x 7.87 x 12.7)	SIL10E-12W3V3-VJ
15 A	3.0-5.5 Vdc	0.8-3.63 V	94%	2" x 0.31" x 0.5" (50.8 x 7.87 x 12.7)	SIL15E-05W3V3-VJ
15 A	10-14 Vdc	0.8-3.63 V	94%	2" x 0.31" x 0.5" (50.8 x 7.87 x 12.7)	SIL15E-12W3V3-VJ
30 A	8.0-14 Vdc	0.8-3.63 V	93%	2" x 0.31" x 0.5" (50.8 x 7.87 x 12.7)	SIL30E-12W3V3-VJ
Surface-Mounting					
5 A	3.0-5.5 Vdc	0.75-3.63 V	94%	0.8" x 0.45" x 0.26" (20.32 x 11.43 x 6.6)	SMT05E-05W3V3J
5 A	10-14 Vdc	0.8-3.63 V	91%	0.8" x 0.45" x 0.24" (20.32 x 11.43 x 6.1)	SMT05E-12W3V3J
10 A	3.0-5.5 Vdc	0.8-3.63 V	96%	1.3" x 0.53" x 0.32" (33.02 x 13.46 x 8.13)	SMT10E-05W3V3J
10 A	10-14 Vdc	0.8-3.63 V	94%	1.3" x 0.53" x 0.32" (33.02 x 13.46 x 8.13)	SMT10E-12W3V3J
15 A	3.0-5.5 Vdc	0.8-3.63 V	95%	1.3" x 0.53" x 0.32" (33.02 x 13.46 x 8.13)	SMT15E-05W3V3J
15 A	10-14 Vdc	0.8-3.63 V	94%	1.3" x 0.53" x 0.32" (33.02 x 13.46 x 8.13)	SMT15E-12W3V3J
30 A	8.0-14 Vdc	0.8-3.63 V	91%	1.3" x 0.53" x 0.32" (33.02 x 13.46 x 8.13)	SMT30E-12W3V3J

POLA – General Purpose

Choose POLA modules for multi-sourced and interoperable parts.

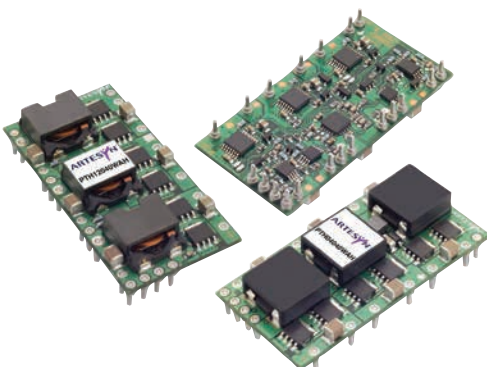

Special Features

- Input voltage ranges: 2.95-3.65 V, 4.5-5.5 V, 10.8-13.2 V
- Wide output voltage trim and adjustability: 0.8-5.5 V
- Output current: 6-60 A
- High efficiency up to 96%
- Auto-Track™ Sequencing
- Margin up/down controls
- Pre-bias start up capability
- Remote on/off
- Remote sense
- POLA compatible
- True multi-sourcing flexibility (form, fit and function)
- Operating temperature range: -40 °C to 85 °C
- Protection: overcurrent/short-circuit
- Through-hole or surface-mount
- International safety standard approvals – UL, CSA, TÜV & CB Report

General Purpose POLA Non-Isolated DC-DC Converters

Output Current	Input Voltage	Output Voltage	Efficiency	Package L x W x H (mm)	Model Number*
6 A	2.95-3.65 Vdc	0.8-2.5 V	94%	0.87" x 0.495" x 0.335" (22.01 x 12.57 x 8.51)	PTH03050WAD
6 A	4.5-5.5 Vdc	0.8-3.6 V	95%	0.87" x 0.495" x 0.335" (22.01 x 12.57 x 8.51)	PTH05050WAD
6 A	10.8-13.2 Vdc	1.2-5.5 V	93%	0.87" x 0.495" x 0.335" (22.01 x 12.57 x 8.51)	PTH12050WAD
8 A	2.95-3.65 Vdc	0.8-2.5 V	93%	0.9" x 0.33" x 0.4" (22.86 x 8.38 x 10.16)	PTV03010WAD
8 A	4.5-5.5 Vdc	0.8-3.6 V	95%	0.9" x 0.33" x 0.4" (22.86 x 8.38 x 10.16)	PTV05010WAD
8 A	10.8-3.2 Vdc	1.2-5.5 V	92%	0.9" x 0.33" x 0.4" (22.86 x 8.38 x 10.16)	PTV12010WAD
10 A	2.95-3.65 Vdc	0.8-2.5 V	93%	0.995" x 0.62" x 0.354" (25.27 x 15.75 x 8.99)	PTH03060WAD
10 A	4.5-5.5 Vdc	0.8-3.6 V	94%	0.995" x 0.62" x 0.354" (25.27 x 15.75 x 8.99)	PTH05060WAD
10 A	10.8-3.2 Vdc	1.2-5.5 V	94%	0.995" x 0.62" x 0.354" (25.27 x 15.75 x 8.99)	PTH12060WAD
12 A	10.8-13.2 Vdc	1.2-5.5 V	94%	1.370" x 0.62" x 0.354" (34.80 x 15.75 x 8.99)	PTH12010WAD
15 A	2.95-3.65 Vdc	0.8-2.5 V	93%	1.370" x 0.62" x 0.354" (34.80 x 15.75 x 8.99)	PTH03010WAD
15 A	4.5-5.5 Vdc	0.8-3.6 V	95%	1.370" x 0.62" x 0.354" (34.80 x 15.75 x 8.99)	PTH05010WAD
16 A	10.8-13.2 Vdc	1.2-5.5 V	93%	1.750" x 0.37" x 0.500" (44.45 x 9.4 x 12.7)	PTV12020WAD
18 A	2.95-3.6 Vdc	0.8-2.5 V	95%	1.750" x 0.37" x 0.500" (44.45 x 9.4 x 12.7)	PTV03020WAD
18 A	4.5-5.5 Vdc	0.8-3.6 V	94%	1.750" x 0.37" x 0.500" (44.45 x 9.4 x 12.7)	PTV05020WAD
18 A	10.8-13.2 Vdc	1.2-5.5 V	95%	1.495" x 0.87" x 0.354" (37.97 x 22.01 x 8.99)	PTH12020WAD
22 A	2.95-3.65 Vdc	0.8-2.5 V	95%	1.495" x 0.87" x 0.354" (37.97 x 22.01 x 8.99)	PTH03020WAD
22 A	4.5-5.5 Vdc	0.8-3.6 V	96%	1.495" x 0.87" x 0.354" (37.97 x 22.01 x 8.99)	PTH05020WAD
26 A	10.2-13.8 Vdc	1.2-5.5 V	95%	1.37" x 1.12" x 0.354" (34.80 x 28.45 x 8.99)	PTH12030WAD
30 A	2.95-3.65 Vdc	0.8-2.5 V	93%	1.37" x 1.12" x 0.354" (34.80 x 28.45 x 8.99)	PTH03030WAD
30 A	4.5-5.5 Vdc	0.8-3.6 V	94%	1.37" x 1.12" x 0.354" (34.80 x 28.45 x 8.99)	PTH05030WAD
50 A	8.0-14 Vdc	0.8-5.5 V	96%	2.045" x 1.045" x 0.357" (51.94 x 26.54 x 9.07)	PTH12040WAD
60 A	2.95-2.5 Vdc	0.8-2.5 V	96%	2.045" x 1.045" x 0.357" (51.94 x 26.54 x 9.07)	PTH04040WAD

* Mounting Option Suffix:

D Horizontal through-hole (RoHS 6/6)

Z Surface-mount solder ball (RoHS 6/6)

Digital DC-DC Converters



Special Features

- PMBus compliant control and monitoring functions available on all digital DC-DC products
- Popular monitoring functions such as temperature, voltage and current are all available
- Control functions for enabling and sequencing are all available.

Isolated DC-DC Special Features

- Isolated DC-DC converters follow the DOSA standard footprints for digital interface bricks

Vout	Iout	Input Voltage	Package size	Efficiency	Model Number
12 Vdc	26 A	48 V (36-75 V)	Eighth brick	95%	ADO300-48S12-6LI
	26 A	48 V (36-75 V)	Eighth brick	95%	ADO300-48S12B-6LI
	42 A	48 V (36-75 V)	Quarter brick	95%	ADQ500-48S12-6LI
	42 A	48 V (36-75 V)	Quarter brick	95%	ADQ500-48S12B-6LI
	58 A	48 V (40-60 V)	Quarter brick	96%	ADQ700-48S12-LI
	58 A	48 V (40-60 V)	Quarter brick	96%	ADQ700-48S12B-6LI
	NEW! 90 A	48 V (40-60 V)	Quarter brick	97.5%	BDQ1300-48S12B-4LI

Non-Isolated DC-DC Special Features

- Non Isolated LGA50D has dual independently controlled channels of up to 25 A per channel
- Non Isolated LGA80D has dual independently controlled channels of up to 40 A per channel
- Provides current density of 160 A per Sq-Inch
- Evaluation Kit available

Output Current	Input Voltage	Output Voltage	Efficiency	Package L x W x H (mm)	Model Number
NEW! Total Output: 50 A	7.5-14 Vdc	0.6-3.3 Vdc	95.5%	1" x 0.5" x 0.48" (25.4 x 12.7 x 5.85)	LGA50D-01DADJ
Channel 1: 25 A	7.5-14 Vdc	0.6-5 Vdc	95.5%	1" x 0.5" x 0.48" (25.4 x 12.7 x 12.2)	LGA50D-01DADJ
Channel 2: 25 A	7.5-14 Vdc	0.6-5 Vdc	95.5%	1" x 0.5" x 0.48" (25.4 x 12.7 x 10.6)	LGA50D-01DADJ
Total Output: 80 A	7.5-14 Vdc	0.6-5 Vdc	95.5%	1" x 0.5" x 0.48" (25.4 x 12.7 x 12.2)	LGA80D-00DADJJ
Channel 1: 40 A	7.5-14 Vdc	0.6-5 Vdc	95.5%	1" x 0.5" x 0.48" (25.4 x 12.7 x 12.2)	LGA80D-00DADJJ
Channel 2: 40 A	7.5-14 Vdc	0.6-5 Vdc	95.5%	1" x 0.5" x 0.48" (25.4 x 12.7 x 12.2)	LGA80D-00DADJJ



LGA80D-00SADJJ



LGA50D-EVAL-KIT

On-board AC-DC Distributed Architecture

- High power and high density AC-DC building blocks for quick-turn and modular power solutions
- Alternative power solutions vs. custom development approach
- No fans and high reliability (1M hours MTBF)
- Suitable for harsh temperature conditions (-40 °C startup/-20 °C to 100 °C operating temperature)
- RTCA-DO Compliant for some AIQ/AIT models

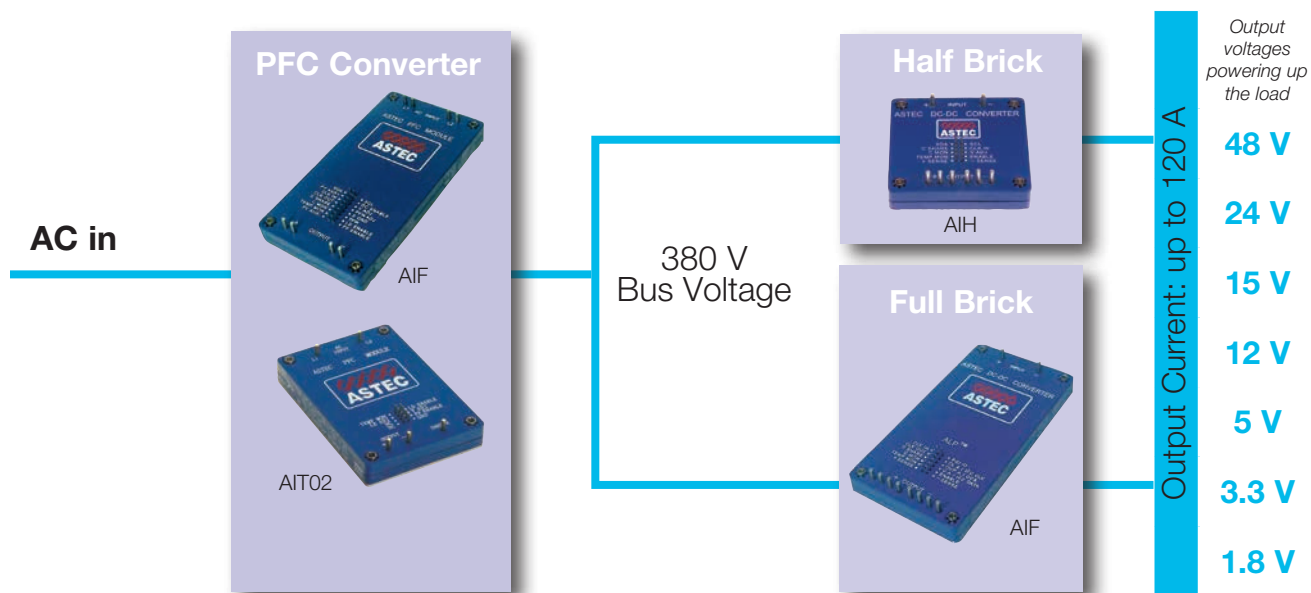

Power Factor Correction (PFC)



Special Features

- 1600 W/720 W/75 W
- Unity power factor
- Universal input and frequency range
- Positive and negative enable
- Paralleling with current share
- IEC 1000-3.2 compliance
- 100 °C baseplate
- Clock synch (in/out)
- Current monitoring
- Vout adjust
- On/off enable
- Remote sense
- 95% efficiency
- Fast transient response

Vout	Iout	Input Voltage	Package L x W x H (mm)	Efficiency	Model Number
PFC Module - Baseplate					
380 V	4.2 A	85-264 Vac	4.6" x 2.4" x 0.5" (116.84 x 60.96 x 12.7)	95%	AIF04ZPFC-01L
380 V	4.2 A	85-264 Vac	4.6" x 2.4" x 0.5" (116.84 x 60.96 x 12.7)	95%	AIF04ZPFC-02L
393 V	0.25 A	100-122 Vac	2.3" x 1.45" x 0.5" (58.42 x 36.83 x 12.7)	90%	AIQ00ZPFC-01NL
393 V	2.08 A	85-264 Vac	3.5" x 2.4" x 0.5" (88.9 x 60.96 x 12.7)	93%	AIT02ZPFC-01NL
NEW! 400 V	6 A	85-264 Vac	4.6" x 2.4" x 0.55" (116.8 x 60.96 x 13.95)	97%	AIF06ZPFC-01L
NEW! 400 V	6 A	85-264 Vac	4.6" x 2.4" x 0.55" (116.8 x 60.96 x 13.95)	97%	AIF06ZPFC-02L

*85 °C temperature

High Power 300 Vin



300 V input 65-600 W output

Special Features

- 300 V input (250-420 V PFC-ready)
- 2nd generation product
- Standard through-hole termination
- Power density > 100 W/in³
- 100 °C max baseplate operating temperature
- Embedded controls on secondary side (Full- and Half-brick):
 - Temp monitor
 - Current sharing
 - Power good signal
 - Current limit & OVP adjust

Vout	Iout	Input Voltage	Package L x W x H (mm)	Efficiency	Model Number
AIF 300 Vin Full-Brick – Baseplate					
1.8 V	120 A	300 V (250-420 V)	4.6" x 2.4" x 0.5" (116.84 x 60.96 x 12.7)	80%	AIF120Y300-L
3.3 V	120 A	300 V (250-420 V)	4.6" x 2.4" x 0.5" (116.84 x 60.96 x 12.7)	87%	AIF120F300-L
5 V	80 A	300 V (250-420 V)	4.6" x 2.4" x 0.5" (116.84 x 60.96 x 12.7)	90%	AIF80A300-L
12 V	50 A	300 V (250-420 V)	4.6" x 2.4" x 0.5" (116.84 x 60.96 x 12.7)	90%	AIF50B300-L
15 V	40 A	300 V (250-420 V)	4.6" x 2.4" x 0.5" (116.84 x 60.96 x 12.7)	90%	AIF40C300-L
24 V	25 A	300 V (250-420 V)	4.6" x 2.4" x 0.5" (116.84 x 60.96 x 12.7)	90%	AIF25H300-L
48 V	12 A	300 V (250-420 V)	4.6" x 2.4" x 0.5" (116.84 x 60.96 x 12.7)	91%	AIF12W300-L
AIH 300 Vin Half-Brick – Baseplate					
1.8 V	50 A	300 V (250-420 V)	2.3" x 2.4" x 0.5" (58.42 x 60.96 x 12.7)	80%	AIH50Y300-L
3.3 V	50 A	300 V (250-420 V)	2.3" x 2.4" x 0.5" (58.42 x 60.96 x 12.7)	85%	AIH50F300-L
5 V	40 A	300 V (250-420 V)	2.3" x 2.4" x 0.5" (58.42 x 60.96 x 12.7)	88%	AIH40A300-L
12 V	20 A	300 V (250-420 V)	2.3" x 2.4" x 0.5" (58.42 x 60.96 x 12.7)	90%	AIH20B300-L
15 V	16 A	300 V (250-420 V)	2.3" x 2.4" x 0.5" (58.42 x 60.96 x 12.7)	90%	AIH16C300-L
24 V	10 A	300 V (250-420 V)	2.3" x 2.4" x 0.5" (58.42 x 60.96 x 12.7)	90%	AIH10H300-L
AIQ 300 Vin Quarter-Brick – Baseplate					
28 V	2.32 A	300 V (250-420 V)	2.3" x 1.45" x 0.5" (58.42 x 36.83 x 12.7)	89%	AIQ02R300L

* 85 °C temperature

Low Power Isolated DC-DC Product



Special Features

- Input voltages 9-36 V, 18-36 V, 18-75 V and 36-75 V
- Single and dual outputs
- Power 2-50 W
- Regulated outputs
- Overcurrent protection
- Operating temperature -40 °C to 71 °C (ambient)
- 1500 Vdc isolation
- CE Mark Safety
- UL Approval (Except AET Series)

	Input Voltage	Output Voltage	Package L x W x H (mm)	I/O Isolation	Efficiency	Model Number
2 W	Enclosed					
	4.5-10 Vdc	3.3 V @ 0.6 A	0.55" x 0.55" x 0.31" (14 x 14 x 8)	1500 Vdc	79%	AYA00F05-L
	4.5-10 Vdc	5 V @ 0.6 A	0.55" x 0.55" x 0.31" (14 x 14 x 8)	1500 Vdc	81%	AYA00A05-L
	4.5-10 Vdc	12 V @ 0.25 A	0.55" x 0.55" x 0.31" (14 x 14 x 8)	1500 Vdc	85%	AYA00B05-L
	4.5-10 Vdc	15 V @ 0.2 A	0.55" x 0.55" x 0.31" (14 x 14 x 8)	1500 Vdc	85%	AYA00C05-L
	4.5-10 Vdc	±5 V @ 0.3 A	0.55" x 0.55" x 0.31" (14 x 14 x 8)	1500 Vdc	82%	AYA00AA05-L
	4.5-10 Vdc	±12 V @ 0.125 A	0.55" x 0.55" x 0.31" (14 x 14 x 8)	1500 Vdc	84%	AYA00BB05-L
	4.5-10 Vdc	±15 V @ 0.1 A	0.55" x 0.55" x 0.31" (14 x 14 x 8)	1500 Vdc	85%	AYA00CC05-L
	9-18 Vdc	3.3 V @ 0.6 A	0.55" x 0.55" x 0.31" (14 x 14 x 8)	1500 Vdc	80%	AYA00F12-L
	9-18 Vdc	5 V @ 0.6 A	0.55" x 0.55" x 0.31" (14 x 14 x 8)	1500 Vdc	83%	AYA00A12-L
	9-18 Vdc	12 V @ 0.25 A	0.55" x 0.55" x 0.31" (14 x 14 x 8)	1500 Vdc	87%	AYA00B12-L
	9-18 Vdc	15 V @ 0.2 A	0.55" x 0.55" x 0.31" (14 x 14 x 8)	1500 Vdc	87%	AYA00C12-L
	9-18 Vdc	±5 V @ 0.3 A	0.55" x 0.55" x 0.31" (14 x 14 x 8)	1500 Vdc	84%	AYA00AA12-L
	9-18 Vdc	±12 V @ 0.125 A	0.55" x 0.55" x 0.31" (14 x 14 x 8)	1500 Vdc	86%	AYA00BB12-L
	9-18 Vdc	±15 V @ 0.1 A	0.55" x 0.55" x 0.31" (14 x 14 x 8)	1500 Vdc	87%	AYA00CC12-L
	18-36 Vdc	3.3 V @ 0.6 A	0.55" x 0.55" x 0.31" (14 x 14 x 8)	1500 Vdc	80%	AYA00F24-L
	18-36 Vdc	5 V @ 0.6 A	0.55" x 0.55" x 0.31" (14 x 14 x 8)	1500 Vdc	83%	AYA00A24-L
	18-36 Vdc	12 V @ 0.25 A	0.55" x 0.55" x 0.31" (14 x 14 x 8)	1500 Vdc	87%	AYA00B24-L
	18-36 Vdc	15 V @ 0.2 A	0.55" x 0.55" x 0.31" (14 x 14 x 8)	1500 Vdc	87%	AYA00C24-L
	18-36 Vdc	±5 V @ 0.3 A	0.55" x 0.55" x 0.31" (14 x 14 x 8)	1500 Vdc	84%	AYA00AA24-L
	18-36 Vdc	±12 V @ 0.125 A	0.55" x 0.55" x 0.31" (14 x 14 x 8)	1500 Vdc	86%	AYA00BB24-L
	18-36 Vdc	±15 V @ 0.1 A	0.55" x 0.55" x 0.31" (14 x 14 x 8)	1500 Vdc	87%	AYA00CC24-L
	36-75 Vdc	3.3 V @ 0.6 A	0.55" x 0.55" x 0.31" (14 x 14 x 8)	1500 Vdc	79%	AYA00F48-L
	36-75 Vdc	5 V @ 0.6 A	0.55" x 0.55" x 0.31" (14 x 14 x 8)	1500 Vdc	82%	AYA00A48-L
	36-75 Vdc	12 V @ 0.25 A	0.55" x 0.55" x 0.31" (14 x 14 x 8)	1500 Vdc	86%	AYA00B48-L
	36-75 Vdc	15 V @ 0.2 A	0.55" x 0.55" x 0.31" (14 x 14 x 8)	1500 Vdc	86%	AYA00C48-L
	36-75 Vdc	±5 V @ 0.3 A	0.55" x 0.55" x 0.31" (14 x 14 x 8)	1500 Vdc	82%	AYA00AA48-L
	36-75 Vdc	±12 V @ 0.125 A	0.55" x 0.55" x 0.31" (14 x 14 x 8)	1500 Vdc	85%	AYA00BB48-L
36-75 Vdc	±15 V @ 0.1 A	0.55" x 0.55" x 0.31" (14 x 14 x 8)	1500 Vdc	85%	AYA00CC48-L	
3 W	Enclosed					
	4.5-10 Vdc	3.3 V @ 0.6 A	0.55" x 0.55" x 0.31" (14 x 14 x 8)	1500 Vdc	79%	AYA01F05-L
	4.5-10 Vdc	5 V @ 0.6 A	0.55" x 0.55" x 0.31" (14 x 14 x 8)	1500 Vdc	81%	AYA01A05-L
	4.5-10 Vdc	12 V @ 0.25 A	0.55" x 0.55" x 0.31" (14 x 14 x 8)	1500 Vdc	85%	AYA01B05-L
	4.5-10 Vdc	15 V @ 0.2 A	0.55" x 0.55" x 0.31" (14 x 14 x 8)	1500 Vdc	85%	AYA01C05-L
	4.5-10 Vdc	±5 V @ 0.3 A	0.55" x 0.55" x 0.31" (14 x 14 x 8)	1500 Vdc	82%	AYA01AA05-L
	4.5-10 Vdc	±12 V @ 0.125 A	0.55" x 0.55" x 0.31" (14 x 14 x 8)	1500 Vdc	84%	AYA01BB05-L
	4.5-10 Vdc	±15 V @ 0.1 A	0.55" x 0.55" x 0.31" (14 x 14 x 8)	1500 Vdc	85%	AYA01CC05-L
	9-18 Vdc	3.3 V @ 0.6 A	0.55" x 0.55" x 0.31" (14 x 14 x 8)	1500 Vdc	80%	AYA01F12-L

Input Voltage	Output Voltage	Package L x W x H (mm)	I/O Isolation	Efficiency	Model Number
9-18 Vdc	5 V @ 0.6 A	0.55" x 0.55" x 0.31" (14 x 14 x 8)	1500 Vdc	83%	AYA01A12-L
9-18 Vdc	12 V @ 0.25 A	0.55" x 0.55" x 0.31" (14 x 14 x 8)	1500 Vdc	87%	AYA01B12-L
9-18 Vdc	15 V @ 0.2 A	0.55" x 0.55" x 0.31" (14 x 14 x 8)	1500 Vdc	87%	AYA01C12-L
9-18 Vdc	±5 V @ 0.3 A	0.55" x 0.55" x 0.31" (14 x 14 x 8)	1500 Vdc	84%	AYA01AA12-L
9-18 Vdc	±12 V @ 0.125 A	0.55" x 0.55" x 0.31" (14 x 14 x 8)	1500 Vdc	86%	AYA01BB12-L
9-18 Vdc	±15 V @ 0.1 A	0.55" x 0.55" x 0.31" (14 x 14 x 8)	1500 Vdc	87%	AYA01CC12-L
9-36 Vdc	3.3 V @ 0.6 A	0.94" x 0.54" x 0.31" (23.8 x 13.7 x 8)	1500 Vdc	75%	ATA00F18-L
9-36 Vdc	3.3 V @ 0.6 A	0.94" x 0.54" x 0.31" (23.8 x 13.7 x 8) SMT	1500 Vdc	75%	ATA00F18S-L
9-36 Vdc	5 V @ 0.6 A	0.94" x 0.54" x 0.31" (23.8 x 13.7 x 8)	1500 Vdc	78%	ATA00A18-L
9-36 Vdc	5 V @ 0.6 A	0.94" x 0.54" x 0.31" (23.8 x 13.7 x 8) SMT	1500 Vdc	78%	ATA00A18S-L
9-36 Vdc	12 V @ 0.25 A	0.94" x 0.54" x 0.31" (23.8 x 13.7 x 8)	1500 Vdc	80%	ATA00B18-L
9-36 Vdc	12 V @ 0.25 A	0.94" x 0.54" x 0.31" (23.8 x 13.7 x 8) SMT	1500 Vdc	80%	ATA00B18S-L
9-36 Vdc	15 V @ 0.2 A	0.94" x 0.54" x 0.31" (23.8 x 13.7 x 8)	1500 Vdc	80%	ATA00C18-L
9-36 Vdc	15 V @ 0.2 A	0.94" x 0.54" x 0.31" (23.8 x 13.7 x 8) SMT	1500 Vdc	80%	ATA00C18S-L
9-36 Vdc	24 V @ 0.125 A	0.94" x 0.54" x 0.31" (23.8 x 13.7 x 8)	1500 Vdc	80%	ATA00H18-L
9-36 Vdc	24 V @ 0.125 A	0.94" x 0.54" x 0.31" (23.8 x 13.7 x 8) SMT	1500 Vdc	80%	ATA00H18S-L
9-36 Vdc	±5 V @ 0.3 A	0.94" x 0.54" x 0.31" (23.8 x 13.7 x 8)	1500 Vdc	77%	ATA00AA18-L
9-36 Vdc	±5 V @ 0.3 A	0.94" x 0.54" x 0.31" (23.8 x 13.7 x 8) SMT	1500 Vdc	77%	ATA00AA18S-L
9-36 Vdc	±12 V @ 0.125 A	0.94" x 0.54" x 0.31" (23.8 x 13.7 x 8)	1500 Vdc	80%	ATA00BB18-L
9-36 Vdc	±12 V @ 0.125 A	0.94" x 0.54" x 0.31" (23.8 x 13.7 x 8) SMT	1500 Vdc	80%	ATA00BB18S-L
9-36 Vdc	±15 V @ 0.1 A	0.94" x 0.54" x 0.31" (23.8 x 13.7 x 8)	1500 Vdc	80%	ATA00CC18-L
9-36 Vdc	±15 V @ 0.1 A	0.94" x 0.54" x 0.31" (23.8 x 13.7 x 8) SMT	1500 Vdc	80%	ATA00CC18S-L
18-36 Vdc	3.3 V @ 0.6 A	0.55" x 0.55" x 0.31" (14 x 14 x 8)	1500 Vdc	80%	AYA01F24-L
18-36 Vdc	5 V @ 0.6 A	0.55" x 0.55" x 0.31" (14 x 14 x 8)	1500 Vdc	83%	AYA01A24-L
18-36 Vdc	12 V @ 0.25 A	0.55" x 0.55" x 0.31" (14 x 14 x 8)	1500 Vdc	87%	AYA01B24-L
18-36 Vdc	15 V @ 0.2 A	0.55" x 0.55" x 0.31" (14 x 14 x 8)	1500 Vdc	87%	AYA01C24-L
18-36 Vdc	±5 V @ 0.3 A	0.55" x 0.55" x 0.31" (14 x 14 x 8)	1500 Vdc	84%	AYA01AA24-L
18-36 Vdc	±12 V @ 0.125 A	0.55" x 0.55" x 0.31" (14 x 14 x 8)	1500 Vdc	86%	AYA01BB24-L
18-36 Vdc	±15 V @ 0.1 A	0.55" x 0.55" x 0.31" (14 x 14 x 8)	1500 Vdc	87%	AYA01CC24-L
18-75 Vdc	3.3 V @ 0.6 A	0.94" x 0.54" x 0.31" (23.8 x 13.7 x 8)	1500 Vdc	75%	ATA00F36-L
18-75 Vdc	3.3 V @ 0.6 A	0.94" x 0.54" x 0.31" (23.8 x 13.7 x 8) SMT	1500 Vdc	75%	ATA00F36S-L
18-75 Vdc	5 V @ 0.6 A	0.94" x 0.54" x 0.31" (23.8 x 13.7 x 8)	1500 Vdc	78%	ATA00A36-L
18-75 Vdc	5 V @ 0.6 A	0.94" x 0.54" x 0.31" (23.8 x 13.7 x 8) SMT	1500 Vdc	78%	ATA00A36S-L
18-75 Vdc	12 V @ 0.25 A	0.94" x 0.54" x 0.31" (23.8 x 13.7 x 8)	1500 Vdc	80%	ATA00B36-L
18-75 Vdc	12 V @ 0.25 A	0.94" x 0.54" x 0.31" (23.8 x 13.7 x 8) SMT	1500 Vdc	80%	ATA00B36S-L
18-75 Vdc	15 V @ 0.2 A	0.94" x 0.54" x 0.31" (23.8 x 13.7 x 8)	1500 Vdc	80%	ATA00C36-L
18-75 Vdc	15 V @ 0.2 A	0.94" x 0.54" x 0.31" (23.8 x 13.7 x 8) SMT	1500 Vdc	80%	ATA00C36S-L
18-75 Vdc	24 V @ 0.125 A	0.94" x 0.54" x 0.31" (23.8 x 13.7 x 8)	1500 Vdc	80%	ATA00H36-L
18-75 Vdc	24 V @ 0.125 A	0.94" x 0.54" x 0.31" (23.8 x 13.7 x 8) SMT	1500 Vdc	80%	ATA00H36S-L
18-75 Vdc	±5 V @ 0.3 A	0.94" x 0.54" x 0.31" (23.8 x 13.7 x 8)	1500 Vdc	77%	ATA00AA36-L
18-75 Vdc	±5 V @ 0.3 A	0.94" x 0.54" x 0.31" (23.8 x 13.7 x 8) SMT	1500 Vdc	77%	ATA00AA36S-L
18-75 Vdc	±12 V @ 0.125 A	0.94" x 0.54" x 0.31" (23.8 x 13.7 x 8)	1500 Vdc	80%	ATA00BB36-L
18-75 Vdc	±12 V @ 0.125 A	0.94" x 0.54" x 0.31" (23.8 x 13.7 x 8) SMT	1500 Vdc	80%	ATA00BB36S-L
18-75 Vdc	±15 V @ 0.1 A	0.94" x 0.54" x 0.31" (23.8 x 13.7 x 8)	1500 Vdc	80%	ATA00CC36-L
18-75 Vdc	±15 V @ 0.1 A	0.94" x 0.54" x 0.31" (23.8 x 13.7 x 8) SMT	1500 Vdc	80%	ATA00CC36S-L
36-75 Vdc	3.3 V @ 0.6 A	0.55" x 0.55" x 0.31" (14 x 14 x 8)	1500 Vdc	79%	AYA01F48-L
36-75 Vdc	5 V @ 0.6 A	0.55" x 0.55" x 0.31" (14 x 14 x 8)	1500 Vdc	82%	AYA01A48-L
36-75 Vdc	12 V @ 0.25 A	0.55" x 0.55" x 0.31" (14 x 14 x 8)	1500 Vdc	86%	AYA01B48-L
36-75 Vdc	15 V @ 0.2 A	0.55" x 0.55" x 0.31" (14 x 14 x 8)	1500 Vdc	86%	AYA01C48-L
36-75 Vdc	±5 V @ 0.3 A	0.55" x 0.55" x 0.31" (14 x 14 x 8)	1500 Vdc	82%	AYA01AA48-L
36-75 Vdc	±12 V @ 0.125 A	0.55" x 0.55" x 0.31" (14 x 14 x 8)	1500 Vdc	85%	AYA01BB48-L
36-75 Vdc	±15 V @ 0.1 A	0.55" x 0.55" x 0.31" (14 x 14 x 8)	1500 Vdc	85%	AYA01CC48-L

	Input Voltage	Output Voltage	Package L x W x H (mm)	I/O Isolation	Efficiency	Model Number
6 W	Enclosed					
	9-36 Vdc	3.3 V @ 1.2 A	0.942" x 0.54" x 0.31" (23.8 x 13.7 x 8)	1500 Vdc	78%	ATA01F18-L
	9-36 Vdc	3.3 V @ 1.2 A	DIP 1.25" x 0.8" x 0.4" (31.75 x 20.32 x 10.16)	1500 Vdc	78%	ASA01F18-LS
	9-36 Vdc	5 V @ 1 A	DIP 1.25" x 0.8" x 0.4" (31.75 x 20.32 x 10.16)	1500 Vdc	81%	ASA01A18-LS
	9-36 Vdc	5 V @ 1.2 A	0.942" x 0.54" x 0.31" (23.8 x 13.7 x 8)	1500 Vdc	82%	ATA01A18-L
	9-36 Vdc	5 V @ ±0.5 A	DIP 1.25" x 0.8" x 0.4" (31.75 x 20.32 x 10.16)	1500 Vdc	81%	ASA00AA18-LS
	9-36 Vdc	15 V @ 0.4 A	DIP 1.25" x 0.8" x 0.4" (31.75 x 20.32 x 10.16)	1500 Vdc	83%	ASA00C18-LS
	9-36 Vdc	12 V @ 0.5 A	0.942" x 0.54" x 0.31" (23.8 x 13.7 x 8)	1500 Vdc	85%	ATA01B18-L
	9-36 Vdc	12 V @ 0.5 A	DIP 1.25" x 0.8" x 0.4" (31.75 x 20.32 x 10.16)	1500 Vdc	82%	ASA00B18-LS
	9-36 Vdc	12 V @ ±0.25 A	DIP 1.25" x 0.8" x 0.4" (31.75 x 20.32 x 10.16)	1500 Vdc	82%	ASA00BB18-LS
	9-36 Vdc	15 V @ 0.4 A	0.942" x 0.54" x 0.31" (23.8 x 13.7 x 8)	1500 Vdc	85%	ATA01C18-L
	9-36 Vdc	15 V @ ±0.2 A	DIP 1.25" x 0.8" x 0.4" (31.75 x 20.32 x 10.16)	1500 Vdc	83%	ASA00CC18-LS
	9-36 Vdc	24 V @ 0.25 A	0.942" x 0.54" x 0.31" (23.8 x 13.7 x 8)	1500 Vdc	86%	ATA01H18-L
	9-36 Vdc	±12 V @ 0.25 A	0.942" x 0.54" x 0.31" (23.8 x 13.7 x 8)	1500 Vdc	85%	ATA01BB18-L
	9-36 Vdc	±15 V @ 0.2 A	0.942" x 0.54" x 0.31" (23.8 x 13.7 x 8)	1500 Vdc	86%	ATA01CC18-L
	18-75 Vdc	3.3 V @ 1.2 A	0.942" x 0.54" x 0.31" (23.8 x 13.7 x 8)	1500 Vdc	78%	ATA01F36-L
	18-75 Vdc	3.3 V @ 1.2 A	DIP 1.25" x 0.8" x 0.4" (31.75 x 20.32 x 10.16)	1500 Vdc	78%	ASA01F36-LS
	18-75 Vdc	5 V @ 1 A	DIP 1.25" x 0.8" x 0.4" (31.75 x 20.32 x 10.16)	1500 Vdc	81%	ASA01A36-LS
	18-75 Vdc	5 V @ 1.2 A	0.942" x 0.54" x 0.31" (23.8 x 13.7 x 8)	1500 Vdc	82%	ATA01A36-L
	18-75 Vdc	5 V @ ±0.5 A	DIP 1.25" x 0.8" x 0.4" (31.75 x 20.32 x 10.16)	1500 Vdc	81%	ASA00AA36-LS
	18-75 Vdc	12 V @ 0.5 A	0.942" x 0.54" x 0.31" (23.8 x 13.7 x 8)	1500 Vdc	85%	ATA01B36-L
	18-75 Vdc	12 V @ 0.5 A	DIP 1.25" x 0.8" x 0.4" (31.75 x 20.32 x 10.16)	1500 Vdc	82%	ASA00B36-LS
	18-75 Vdc	12 V @ ±0.25 A	DIP 1.25" x 0.8" x 0.4" (31.75 x 20.32 x 10.16)	1500 Vdc	82%	ASA00BB36-LS
	18-75 Vdc	15 V @ 0.4 A	0.942" x 0.54" x 0.31" (23.8 x 13.7 x 8)	1500 Vdc	85%	ATA01C36-L
	18-75 Vdc	15 V @ 0.4 A	DIP 1.25" x 0.8" x 0.4" (31.75 x 20.32 x 10.16)	1500 Vdc	83%	ASA00C36-LS
	18-75 Vdc	15 V @ ±0.2 A	DIP 1.25" x 0.8" x 0.4" (31.75 x 20.32 x 10.16)	1500 Vdc	83%	ASA00CC36-LS
18-75 Vdc	24 V @ 0.25 A	0.942" x 0.54" x 0.31" (23.8 x 13.7 x 8)	1500 Vdc	86%	ATA01H36-L	
18-75 Vdc	±12 V @ 0.25 A	0.942" x 0.54" x 0.31" (23.8 x 13.7 x 8)	1500 Vdc	85%	ATA01BB36-L	
18-75 Vdc	±15 V @ 0.2 A	0.942" x 0.54" x 0.31" (23.8 x 13.7 x 8)	1500 Vdc	86%	ATA01CC36-L	
8 W	Enclosed					
	9-36 Vdc	3.3 V @ 2 A	0.942" x 0.54" x 0.31" (23.8 x 13.7 x 8)	1500 Vdc	78%	ATA02F18-L
	9-36 Vdc	5 V @ 1.6 A	0.942" x 0.54" x 0.31" (23.8 x 13.7 x 8)	1500 Vdc	82%	ATA02A18-L
	9-36 Vdc	12 V @ 0.665 A	0.942" x 0.54" x 0.31" (23.8 x 13.7 x 8)	1500 Vdc	85%	ATA02B18-L
	9-36 Vdc	15 V @ 0.535 A	0.942" x 0.54" x 0.31" (23.8 x 13.7 x 8)	1500 Vdc	85%	ATA02C18-L
	9-36 Vdc	24 V @ 0.335 A	0.942" x 0.54" x 0.31" (23.8 x 13.7 x 8)	1500 Vdc	86%	ATA02H18-L
	9-36 Vdc	±12 V @ 0.335 A	0.942" x 0.54" x 0.31" (23.8 x 13.7 x 8)	1500 Vdc	85%	ATA02BB18-L
	9-36 Vdc	±15 V @ 0.265 A	0.942" x 0.54" x 0.31" (23.8 x 13.7 x 8)	1500 Vdc	86%	ATA02CC18-L
	18-75 Vdc	3.3 V @ 2 A	0.942" x 0.54" x 0.31" (23.8 x 13.7 x 8)	1500 Vdc	78%	ATA02F36-L
	18-75 Vdc	5 V @ 1.6 A	0.942" x 0.54" x 0.31" (23.8 x 13.7 x 8)	1500 Vdc	82%	ATA02A36-L
	18-75 Vdc	12 V @ 0.665 A	0.942" x 0.54" x 0.31" (23.8 x 13.7 x 8)	1500 Vdc	85%	ATA02B36-L
	18-75 Vdc	15 V @ 0.535 A	0.942" x 0.54" x 0.31" (23.8 x 13.7 x 8)	1500 Vdc	85%	ATA02C36-L
	18-75 Vdc	24 V @ 0.335 A	0.942" x 0.54" x 0.31" (23.8 x 13.7 x 8)	1500 Vdc	86%	ATA02H36-L
	18-75 Vdc	±12 V @ 0.335 A	0.942" x 0.54" x 0.31" (23.8 x 13.7 x 8)	1500 Vdc	85%	ATA02BB36-L
	18-75 Vdc	±15 V @ 0.265 A	0.942" x 0.54" x 0.31" (23.8 x 13.7 x 8)	1500 Vdc	86%	ATA02CC36-L



	Input Voltage	Output Voltage	Package L x W x H (mm)	I/O Isolation	Efficiency	Model Number
10 W	Enclosed					
	9-36 Vdc	3.3 V @ 2.2 A	1" x 1" x 0.4" (25.4 x 25.4 x 10.16)	1500 Vdc	86%	AXA02F18-L
NEW!	9-36 Vdc	3.3 V @ 2.7 A	0.942" x 0.54" x 0.31" (23.8 x 13.7 x 8)	1500 Vdc	80%	ATA03F18-L
NEW!	9-36 Vdc	5 V @ 2 A	0.942" x 0.54" x 0.31" (23.8 x 13.7 x 8)	1500 Vdc	87%	ATA03B18-L
	9-36 Vdc	5 V @ 2 A	1" x 1" x 0.4" (25.4 x 25.4 x 10.16)	1500 Vdc	84%	AXA02A18-L
	9-36 Vdc	12 V @ 0.83 A	1" x 1" x 0.4" (25.4 x 25.4 x 10.16)	1500 Vdc	86%	AXA00B18-L
NEW!	9-36 Vdc	12 V @ 0.833 A	0.942" x 0.54" x 0.31" (23.8 x 13.7 x 8)	1500 Vdc	88%	ATA03H18-L
	9-36 Vdc	15 V @ 0.66 A	1" x 1" x 0.4" (25.4 x 25.4 x 10.16)	1500 Vdc	87%	AXA00C18-L
NEW!	9-36 Vdc	15 V @ 0.666 A	0.942" x 0.54" x 0.31" (23.8 x 13.7 x 8)	1500 Vdc	83%	ATA03A36-L
	9-36 Vdc	24 V @ 0.41 A	1" x 1" x 0.4" (25.4 x 25.4 x 10.16)	1500 Vdc	86%	AXA000H18-L
NEW!	9-36 Vdc	24 V @ 0.416 A	0.942" x 0.54" x 0.31" (23.8 x 13.7 x 8)	1500 Vdc	87%	ATA03BB36-L
	9-36 Vdc	±5 V @ ±1 A	1" x 1" x 0.4" (25.4 x 25.4 x 10.16)	1500 Vdc	84%	AXA00AA18-L
NEW!	9-36 Vdc	±12 V @ 0.416 A	0.942" x 0.54" x 0.31" (23.8 x 13.7 x 8)	1500 Vdc	87%	ATA03CC18-L
	9-36 Vdc	±12 V @ ±0.41 A	1" x 1" x 0.4" (25.4 x 25.4 x 10.16)	1500 Vdc	86%	AXA000BB18-L
NEW!	9-36 Vdc	±15 V @ 0.333 A	0.942" x 0.54" x 0.31" (23.8 x 13.7 x 8)	1500 Vdc	88%	ATA03C36-L
	9-36 Vdc	±15 V @ ±0.33 A	1" x 1" x 0.4" (25.4 x 25.4 x 10.16)	1500 Vdc	87%	AXA000CC18-L
	18-36 Vdc	2.5 V @ 3 A	DIP 1.25" x 0.8" x 0.4" (31.75 x 20.32 x 10.16)	1500 Vdc	77%	ASA03G24-LS
	18-36 Vdc	3.3 V @ 3 A	DIP 1.25" x 0.8" x 0.4" (31.75 x 20.32 x 10.16)	1500 Vdc	79%	ASA03F24-LS
	18-36 Vdc	5 V @ 2 A	DIP 1.25" x 0.8" x 0.4" (31.75 x 20.32 x 10.16)	1500 Vdc	82%	ASA02A24-LS
	18-36 Vdc	12 V @ 0.835 A	DIP 1.25" x 0.8" x 0.4" (31.75 x 20.32 x 10.16)	1500 Vdc	83%	ASA00B24-LS
	18-75 Vdc	3.3 V @ 2.2 A	1" x 1" x 0.4" (25.4 x 25.4 x 10.16)	1500 Vdc	86%	AXA02F36-L
NEW!	18-75 Vdc	3.3 V @ 2.7 A	0.942" x 0.54" x 0.31" (23.8 x 13.7 x 8)	1500 Vdc	83%	ATA03A18-L
NEW!	18-75 Vdc	5 V @ 2 A	0.942" x 0.54" x 0.31" (23.8 x 13.7 x 8)	1500 Vdc	88%	ATA03C18-L
	18-75 Vdc	5 V @ 2 A	1" x 1" x 0.4" (25.4 x 25.4 x 10.16)	1500 Vdc	84%	AXA02A36-L
	18-75 Vdc	12 V @ 0.83 A	1" x 1" x 0.4" (25.4 x 25.4 x 10.16)	1500 Vdc	86%	AXA00B36-L
NEW!	18-75 Vdc	12 V @ 0.833 A	0.942" x 0.54" x 0.31" (23.8 x 13.7 x 8)	1500 Vdc	87%	ATA03BB18-L
	18-75 Vdc	15 V @ 0.66 A	1" x 1" x 0.4" (25.4 x 25.4 x 10.16)	1500 Vdc	87%	AXA00C36-L
NEW!	18-75 Vdc	15 V @ 0.666 A	0.942" x 0.54" x 0.31" (23.8 x 13.7 x 8)	1500 Vdc	87%	ATA03B36-L
	18-75 Vdc	24 V @ 0.41 A	1" x 1" x 0.4" (25.4 x 25.4 x 10.16)	1500 Vdc	86%	AXA000H36-L
NEW!	18-75 Vdc	24 V @ 0.416 A	0.942" x 0.54" x 0.31" (23.8 x 13.7 x 8)	1500 Vdc	87%	ATA03CC36-L
	18-75 Vdc	±5 V @ ±1 A	1" x 1" x 0.4" (25.4 x 25.4 x 10.16)	1500 Vdc	84%	AXA00AA36-L
NEW!	18-75 Vdc	±12 V @ 0.416 A	0.942" x 0.54" x 0.31" (23.8 x 13.7 x 8)	1500 Vdc	80%	ATA03F36-L
	18-75 Vdc	±12 V @ ±0.41 A	1" x 1" x 0.4" (25.4 x 25.4 x 10.16)	1500 Vdc	86%	AXA000BB36-L
NEW!	18-75 Vdc	±15 V @ 0.333 A	0.942" x 0.54" x 0.31" (23.8 x 13.7 x 8)	1500 Vdc	88%	ATA03H36-L
	18-75 Vdc	±15 V @ ±0.33 A	1" x 1" x 0.4" (25.4 x 25.4 x 10.16)	1500 Vdc	87%	AXA000CC36-L
	36-75 Vdc	2.5 V @ 3 A	DIP 1.25" x 0.8" x 0.4" (31.75 x 20.32 x 10.16)	1500 Vdc	87%	ASA03G48-LS
	36-75 Vdc	3.3 V @ 3 A	DIP 1.25" x 0.8" x 0.4" (31.75 x 20.32 x 10.16)	1500 Vdc	79%	ASA03F48-LS
	36-75 Vdc	5 V @ 2 A	DIP 1.25" x 0.8" x 0.4" (31.75 x 20.32 x 10.16)	1500 Vdc	82%	ASA02A48-LS
	36-75 Vdc	12 V @ 0.835 A	DIP 1.25" x 0.8" x 0.4" (31.75 x 20.32 x 10.16)	1500 Vdc	83%	ASA00B48-LS
15 W	Enclosed					
	9-36 Vdc	3.3 V @ 4 A	1" x 2" x 0.44" (25.4 x 50.8 x 11.30)	1500 Vdc	80%	AEE04F18-LS
	9-36 Vdc	5 V @ 3 A	1" x 2" x 0.44" (25.4 x 50.8 x 11.30)	1500 Vdc	84%	AEE03A18-LS
	9-36 Vdc	12 V @ 1.25 A	1" x 2" x 0.44" (25.4 x 50.8 x 11.30)	1500 Vdc	84%	AEE01B18-LS
	9-36 Vdc	15 V @ 1 A	1" x 2" x 0.44" (25.4 x 50.8 x 11.30)	1500 Vdc	84%	AEE01C18-LS
	9-36 Vdc	5 V @ ±1.5 A	1" x 2" x 0.44" (25.4 x 50.8 x 11.30)	1500 Vdc	79%	AEE01AA18-LS
	9-36 Vdc	12 V @ ±0.625 A	1" x 2" x 0.44" (25.4 x 50.8 x 11.30)	1500 Vdc	83%	AEE00BB18-LS
	9-36 Vdc	15 V @ ±0.5 A	1" x 2" x 0.44" (25.4 x 50.8 x 11.30)	1500 Vdc	83%	AEE00CC18-LS
	18-75 Vdc	3.3 V @ 4 A	1" x 2" x 0.44" (25.4 x 50.8 x 11.30)	1500 Vdc	80%	AEE04F36-LS
	18-75 Vdc	5 V @ 3 A	1" x 2" x 0.44" (25.4 x 50.8 x 11.30)	1500 Vdc	84%	AEE03A36-LS
	18-75 Vdc	12 V @ 1.25 A	1" x 2" x 0.44" (25.4 x 50.8 x 11.30)	1500 Vdc	84%	AEE01B36-LS
	18-75 Vdc	15 V @ 1 A	1" x 2" x 0.44" (25.4 x 50.8 x 11.30)	1500 Vdc	84%	AEE01C36-LS
	18-75 Vdc	5 V @ ±1.5 A	1" x 2" x 0.44" (25.4 x 50.8 x 11.30)	1500 Vdc	79%	AEE01AA36-LS
	18-75 Vdc	12 V @ ±0.625 A	1" x 2" x 0.44" (25.4 x 50.8 x 11.30)	1500 Vdc	83%	AEE00BB36-LS
	18-75 Vdc	15 V @ ±0.5 A	1" x 2" x 0.44" (25.4 x 50.8 x 11.30)	1500 Vdc	83%	AEE00CC36-LS

	Input Voltage	Output Voltage	Package L x W x H (mm)	I/O Isolation	Efficiency	Model Number	
20 W	Isolated						
	9-36 Vdc	3.3 V @ 4.5 A	1" x 1" x 0.4" (25.4 x 25.4 x 10.16)	1500 Vdc	87%	AXA04F18-L	
	9-36 Vdc	5 V @ 4 A	1" x 1" x 0.4" (25.4 x 25.4 x 10.16)	1500 Vdc	89%	AXA04A18-L	
	9-36 Vdc	12 V @ 1.67 A	1" x 1" x 0.4" (25.4 x 25.4 x 10.16)	1500 Vdc	89%	AXA01B18-L	
	9-36 Vdc	15 V @ 1.33 A	1" x 1" x 0.4" (25.4 x 25.4 x 10.16)	1500 Vdc	89%	AXA01C18-L	
	9-36 Vdc	24 V @ 0.835 A	1" x 1" x 0.4" (25.4 x 25.4 x 10.16)	1500 Vdc	88%	AXA00H18-L	
	9-36 Vdc	±12 V @ 0.835 A	1" x 1" x 0.4" (25.4 x 25.4 x 10.16)	1500 Vdc	89%	AXA00BB18-L	
	9-36 Vdc	±15 V @ 0.67 A	1" x 1" x 0.4" (25.4 x 25.4 x 10.16)	1500 Vdc	89%	AXA00CC18-L	
	18-75 Vdc	2.5 V @ 6 A	1.6" x 2" x 0.48" (40.6 x 50.8 x 12.19)	1500 Vdc	79%	AET06G36-L	
	18-75 Vdc	3.3 V @ 4.5 A	1" x 1" x 0.4" (25.4 x 25.4 x 10.16)	1500 Vdc	88%	AXA04F36-L	
	18-75 Vdc	3.3 V @ 6 A	1.6" x 2" x 0.48" (40.6 x 50.8 x 12.19)	1500 Vdc	83%	AET06F36-L	
	18-75 Vdc	5 V @ 4 A	1" x 1" x 0.4" (25.4 x 25.4 x 10.16)	1500 Vdc	89%	AXA04A36-L	
	18-75 Vdc	5 V @ 4 A	1.6" x 2" x 0.48" (40.6 x 50.8 x 12.19)	1500 Vdc	84%	AET04A36-L	
	18-75 Vdc	5 V @ ±2 A	1.6" x 2" x 0.48" (40.6 x 50.8 x 12.19)	1500 Vdc	84%	AET02AA36-L	
	18-75 Vdc	12 V @ 1.67 A	1" x 1" x 0.4" (25.4 x 25.4 x 10.16)	1500 Vdc	89%	AXA01B36-L	
	18-75 Vdc	12 V @ 1.67 A	1.6" x 2" x 0.48" (40.6 x 50.8 x 12.19)	1500 Vdc	85%	AET01B36-L	
	18-75 Vdc	12 V @ ±0.835 A	1.6" x 2" x 0.48" (40.6 x 50.8 x 12.19)	1500 Vdc	85%	AET00BB36-L	
	18-75 Vdc	15 V @ 1.33 A	1" x 1" x 0.4" (25.4 x 25.4 x 10.16)	1500 Vdc	89%	AXA01C36-L	
	18-75 Vdc	15 V @ 1.33 A	1.6" x 2" x 0.48" (40.6 x 50.8 x 12.19)	1500 Vdc	85%	AET01C36-L	
	18-75 Vdc	15 V @ ±0.665 A	1.6" x 2" x 0.48" (40.6 x 50.8 x 12.19)	1500 Vdc	85%	AET00CC36-L	
	18-75 Vdc	24 V @ 0.835 A	1" x 1" x 0.4" (25.4 x 25.4 x 10.16)	1500 Vdc	88%	AXA00H36-L	
	18-75 Vdc	±12 V @ 0.835 A	1" x 1" x 0.4" (25.4 x 25.4 x 10.16)	1500 Vdc	89%	AXA00BB36-L	
	18-75 Vdc	±15 V @ 0.67 A	1" x 1" x 0.4" (25.4 x 25.4 x 10.16)	1500 Vdc	89%	AXA00CC36-L	
	25 W	Enclosed					
		9-36 Vdc	2.5 V @ 6 A	1.6" x 2" x 0.48" (40.6 x 50.8 x 12.19)	1500 Vdc	79%	AET06G18-L
		9-36 Vdc	3.3 V @ 6 A	1.6" x 2" x 0.48" (40.6 x 50.8 x 12.19)	1500 Vdc	83%	AET06F18-L
9-36 Vdc		5 V @ 4 A	1.6" x 2" x 0.48" (40.6 x 50.8 x 12.19)	1500 Vdc	84%	AET04A18-L	
9-36 Vdc		5 V @ ±2 A	1.6" x 2" x 0.48" (40.6 x 50.8 x 12.19)	1500 Vdc	84%	AET02AA18-L	
9-36 Vdc		12 V @ 1.67 A	1.6" x 2" x 0.48" (40.6 x 50.8 x 12.19)	1500 Vdc	85%	AET01B18-L	
9-36 Vdc		12 V @ ±0.835 A	1.6" x 2" x 0.48" (40.6 x 50.8 x 12.19)	1500 Vdc	85%	AET00BB18-L	
9-36 Vdc		15 V @ 1.33 A	1.6" x 2" x 0.48" (40.6 x 50.8 x 12.19)	1500 Vdc	85%	AET01C18-L	
9-36 Vdc		15 V @ ±0.665 A	1.6" x 2" x 0.48" (40.6 x 50.8 x 12.19)	1500 Vdc	85%	AET00CC18-L	
9-36 Vdc		3.3 V @ 6 A	1" x 1" x 0.4" (25.4 x 25.4 x 10.16)	1500 Vdc	87%	AXA06F18-L	
9-36 Vdc		5 V @ 5 A	1" x 1" x 0.4" (25.4 x 25.4 x 10.16)	1500 Vdc	89%	AXA05A18-L	
9-36 Vdc		12 V @ 2.09 A	1" x 1" x 0.4" (25.4 x 25.4 x 10.16)	1500 Vdc	89%	AXA02B18-L	
9-36 Vdc		15 V @ 1.67 A	1" x 1" x 0.4" (25.4 x 25.4 x 10.16)	1500 Vdc	90%	AXA02C18-L	
9-36 Vdc		±12 V @ 1.04 A	1" x 1" x 0.4" (25.4 x 25.4 x 10.16)	1500 Vdc	89%	AXA01BB18-L	
9-36 Vdc	±15 V @ 0.84 A	1" x 1" x 0.4" (25.4 x 25.4 x 10.16)	1500 Vdc	89%	AXA01CC18-L		
18-75 Vdc	3.3 V @ 6 A	1" x 1" x 0.4" (25.4 x 25.4 x 10.16)	1500 Vdc	88%	AXA06F36-L		
18-75 Vdc	5 V @ 5 A	1" x 1" x 0.4" (25.4 x 25.4 x 10.16)	1500 Vdc	90%	AXA05A36-L		
18-75 Vdc	12 V @ 2.09 A	1" x 1" x 0.4" (25.4 x 25.4 x 10.16)	1500 Vdc	90%	AXA02B36-L		
18-75 Vdc	15 V @ 1.67 A	1" x 1" x 0.4" (25.4 x 25.4 x 10.16)	1500 Vdc	90%	AXA02C36-L		
18-75 Vdc	±12 V @ 1.04 A	1" x 1" x 0.4" (25.4 x 25.4 x 10.16)	1500 Vdc	89%	AXA01BB36-L		
18-75 Vdc	±15 V @ 0.84 A	1" x 1" x 0.4" (25.4 x 25.4 x 10.16)	1500 Vdc	89%	AXA01CC36-L		

	Input Voltage	Output Voltage	Package L x W x H (mm)	I/O Isolation	Efficiency	Model Number
30 W	Enclosed					
	9-36 Vdc	2.5 V @ 8 A	1.6" x 2" x 0.48" (40.6 x 50.8 x 12.19)	1500 Vdc	79%	AET08G18-L
	9-36 Vdc	3.3 V @ 7 A	1.6" x 2" x 0.48" (40.6 x 50.8 x 12.19)	1500 Vdc	82%	AET07F18-L
	9-36 Vdc	5 V @ 6 A	1.6" x 2" x 0.48" (40.6 x 50.8 x 12.19)	1500 Vdc	84%	AET06A18-L
	9-36 Vdc	12 V @ 2.5 A	1.6" x 2" x 0.48" (40.6 x 50.8 x 12.19)	1500 Vdc	85%	AET02B18-L
	9-36 Vdc	15 V @ 2 A	1.6" x 2" x 0.48" (40.6 x 50.8 x 12.19)	1500 Vdc	85%	AET02C18-L
	9-36 Vdc	12 V @ ±1.25 A	1.6" x 2" x 0.48" (40.6 x 50.8 x 12.19)	1500 Vdc	85%	AET01BB18-L
	9-36 Vdc	15 V @ ±1 A	1.6" x 2" x 0.48" (40.6 x 50.8 x 12.19)	1500 Vdc	85%	AET01CC18-L
	18-75 Vdc	2.5 V @ 8 A	1.6" x 2" x 0.48" (40.6 x 50.8 x 12.19)	1500 Vdc	79%	AET08G36-L
	18-75 Vdc	3.3 V @ 7 A	1.6" x 2" x 0.48" (40.6 x 50.8 x 12.19)	1500 Vdc	82%	AET07F36-L
	18-75 Vdc	5 V @ 6 A	1.6" x 2" x 0.48" (40.6 x 50.8 x 12.19)	1500 Vdc	84%	AET06A36-L
	18-75 Vdc	12 V @ 2.5 A	1.6" x 2" x 0.48" (40.6 x 50.8 x 12.19)	1500 Vdc	85%	AET02B36-L
	18-75 Vdc	15 V @ 2 A	1.6" x 2" x 0.48" (40.6 x 50.8 x 12.19)	1500 Vdc	85%	AET02C36-L
	18-75 Vdc	12 V @ ±1.25 A	1.6" x 2" x 0.48" (40.6 x 50.8 x 12.19)	1500 Vdc	85%	AET01BB36-L
	18-75 Vdc	15 V @ ±1 A	1.6" x 2" x 0.48" (40.6 x 50.8 x 12.19)	1500 Vdc	85%	AET01CC36-L
40 W	Enclosed					
	9-36 Vdc	3.3 V @ 8 A	2" X 1" X 0.4" (25.4 X 50.8 X 10.2)	1500 Vdc	89%	AEE08F18-L
	9-36 Vdc	5 V @ 8 A	2" X 1" X 0.4" (25.4 X 50.8 X 10.2)	1500 Vdc	90%	AEE08A18-L
	9-36 Vdc	12 V @ 3.33 A	2" X 1" X 0.4" (25.4 X 50.8 X 10.2)	1500 Vdc	89%	AEE03B18-L
	9-36 Vdc	15 V @ 2.67 A	2" X 1" X 0.4" (25.4 X 50.8 X 10.2)	1500 Vdc	89%	AEE02C18-L
	9-36 Vdc	24 V @ 1.67 A	2" X 1" X 0.4" (25.4 X 50.8 X 10.2)	1500 Vdc	91%	AEE01H18-L
	9-36 Vdc	±12 V @ 1.67 A	2" X 1" X 0.4" (25.4 X 50.8 X 10.2)	1500 Vdc	88%	AEE01BB18-L
	9-36 Vdc	±15 V @ 1.67 A	2" X 1" X 0.4" (25.4 X 50.8 X 10.2)	1500 Vdc	88%	AEE01CC18-L
	18-75 Vdc	3.3 V @ 8 A	2" X 1" X 0.4" (25.4 X 50.8 X 10.2)	1500 Vdc	89%	AEE08F36-L
	18-75 Vdc	5 V @ 8 A	2" X 1" X 0.4" (25.4 X 50.8 X 10.2)	1500 Vdc	90%	AEE08A36-L
	18-75 Vdc	12 V @ 3.33 A	2" X 1" X 0.4" (25.4 X 50.8 X 10.2)	1500 Vdc	90%	AEE03B36-L
	18-75 Vdc	15 V @ 2.67 A	2" X 1" X 0.4" (25.4 X 50.8 X 10.2)	1500 Vdc	90%	AEE02C36-L
	18-75 Vdc	24 V @ 1.67 A	2" X 1" X 0.4" (25.4 X 50.8 X 10.2)	1500 Vdc	91%	AEE01H36-L
	18-75 Vdc	±12 V @ 1.67 A	2" X 1" X 0.4" (25.4 X 50.8 X 10.2)	1500 Vdc	88%	AEE01BB36-L
	18-75 Vdc	±15 V @ 1.67 A	2" X 1" X 0.4" (25.4 X 50.8 X 10.2)	1500 Vdc	88%	AEE01CC36-L
50 W	Enclosed					
	9-36 Vdc	3.3 V @ 10 A	2" X 1" X 0.4" (25.4 X 50.8 X 10.2)	1500 Vdc	90%	AEE10F18-L
	9-36 Vdc	5 V @ 10 A	2" X 1" X 0.4" (25.4 X 50.8 X 10.2)	1500 Vdc	91%	AEE10A18-L
	9-36 Vdc	12 V @ 4.17 A	2" X 1" X 0.4" (25.4 X 50.8 X 10.2)	1500 Vdc	92%	AEE04B18-L
	9-36 Vdc	15 V @ 3.33 A	2" X 1" X 0.4" (25.4 X 50.8 X 10.2)	1500 Vdc	92%	AEE03C18-L
	9-36 Vdc	24 V @ 2.08 A	2" X 1" X 0.4" (25.4 X 50.8 X 10.2)	1500 Vdc	91%	AEE02H18-L
	18-75 Vdc	3.3 V @ 10 A	2" X 1" X 0.4" (25.4 X 50.8 X 10.2)	1500 Vdc	90%	AEE10F36-L
	18-75 Vdc	5 V @ 10 A	2" X 1" X 0.4" (25.4 X 50.8 X 10.2)	1500 Vdc	91%	AEE10A36-L
	18-75 Vdc	12 V @ 4.17 A	2" X 1" X 0.4" (25.4 X 50.8 X 10.2)	1500 Vdc	92%	AEE04B36-L
	18-75 Vdc	15 V @ 3.33 A	2" X 1" X 0.4" (25.4 X 50.8 X 10.2)	1500 Vdc	92%	AEE03C36-L
	18-75 Vdc	24 V @ 2.08 A	2" X 1" X 0.4" (25.4 X 50.8 X 10.2)	1500 Vdc	91%	AEE02H36-L

DC-DC Converter for Railway Application



ERM40W

	Input Voltage	Output	Package	I/O Isolation	Efficiency	Model Number
10 W	24 (9-36 V)	5 V @ 2 A	2" x 1" x 0.43" (50.8 x 25.4 x 11)	3000 Vac rms	84%	ERM02A18
	24 (9-36 V)	12 V @ 0.83 A	2" x 1" x 0.43" (50.8 x 25.4 x 11)	3000 Vac rms	86%	ERM00B18
	24 (9-36 V)	15 V @ 0.67 A	2" x 1" x 0.43" (50.8 x 25.4 x 11)	3000 Vac rms	86%	ERM00C18
	24 (9-36 V)	24 V @ 0.41 A	2" x 1" x 0.43" (50.8 x 25.4 x 11)	3000 Vac rms	85%	ERM00H18
	24 (9-36 V)	±12 V @ 0.417 A	2" x 1" x 0.43" (50.8 x 25.4 x 11)	3000 Vac rms	86%	ERM00BB18
	24 (9-36 V)	±15 V @ 0.335 A	2" x 1" x 0.43" (50.8 x 25.4 x 11)	3000 Vac rms	87%	ERM00CC18
	48 (18-75 V)	5 V @ 2 A	2" x 1" x 0.43" (50.8 x 25.4 x 11)	3000 Vac rms	84%	ERM02A36
	48 (18-75 V)	12 V @ 0.83 A	2" x 1" x 0.43" (50.8 x 25.4 x 11)	3000 Vac rms	86%	ERM00B36
	48 (18-75 V)	15 V @ 0.67 A	2" x 1" x 0.43" (50.8 x 25.4 x 11)	3000 Vac rms	86%	ERM00C36
	48 (18-75 V)	24 V @ 0.41 A	2" x 1" x 0.43" (50.8 x 25.4 x 11)	3000 Vac rms	85%	ERM00H36
	48 (18-75 V)	±12 V @ 0.417 A	2" x 1" x 0.43" (50.8 x 25.4 x 11)	3000 Vac rms	89%	ERM00BB36
	48 (18-75 V)	±15 V @ 0.335 A	2" x 1" x 0.43" (50.8 x 25.4 x 11)	3000 Vac rms	88%	ERM00CC36
	72, 110 (40-160 V)	5 V @ 2 A	2" x 1" x 0.43" (50.8 x 25.4 x 11)	3000 Vac rms	82%	ERM02A110
	72, 110 (40-160 V)	12 V @ 0.83 A	2" x 1" x 0.43" (50.8 x 25.4 x 11)	3000 Vac rms	85%	ERM00B110
	72, 110 (40-160 V)	15 V @ 0.67 A	2" x 1" x 0.43" (50.8 x 25.4 x 11)	3000 Vac rms	85%	ERM00C110
72, 110 (40-160 V)	24 V @ 0.41 A	2" x 1" x 0.43" (50.8 x 25.4 x 11)	3000 Vac rms	84%	ERM00H110	
72, 110 (40-160 V)	±12 V @ 0.417 A	2" x 1" x 0.43" (50.8 x 25.4 x 11)	3000 Vac rms	86%	ERM00BB110	
72, 110 (40-160 V)	±15 V @ 0.335 A	2" x 1" x 0.43" (50.8 x 25.4 x 11)	3000 Vac rms	86%	ERM00CC110	
20 W	24 (9-36 V)	5 V @ 4 A	2" x 1" x 0.43" (50.8 x 25.4 x 11)	3000 Vac rms	85%	ERM04A18
	24 (9-36 V)	12 V @ 1.67 A	2" x 1" x 0.43" (50.8 x 25.4 x 11)	3000 Vac rms	87%	ERM01B18
	24 (9-36 V)	15 V @ 1.33 A	2" x 1" x 0.43" (50.8 x 25.4 x 11)	3000 Vac rms	87%	ERM01C18
	24 (9-36 V)	24 V @ 0.833 A	2" x 1" x 0.43" (50.8 x 25.4 x 11)	3000 Vac rms	86%	ERM01H18
	24 (9-36 V)	±12 V @ 0.833 A	2" x 1" x 0.43" (50.8 x 25.4 x 11)	3000 Vac rms	86%	ERM01BB18
	24 (9-36 V)	±15 V @ 0.667 A	2" x 1" x 0.43" (50.8 x 25.4 x 11)	3000 Vac rms	86%	ERM01CC18
	48 (18-75 V)	5 V @ 4 A	2" x 1" x 0.43" (50.8 x 25.4 x 11)	3000 Vac rms	85%	ERM04A36
	48 (18-75 V)	12 V @ 1.67 A	2" x 1" x 0.43" (50.8 x 25.4 x 11)	3000 Vac rms	87%	ERM01B36
	48 (18-75 V)	15 V @ 1.33 A	2" x 1" x 0.43" (50.8 x 25.4 x 11)	3000 Vac rms	87%	ERM01C36
	48 (18-75 V)	24 V @ 0.833 A	2" x 1" x 0.43" (50.8 x 25.4 x 11)	3000 Vac rms	86%	ERM01H36
	48 (18-75 V)	±12 V @ 0.833 A	2" x 1" x 0.43" (50.8 x 25.4 x 11)	3000 Vac rms	87%	ERM01BB36
	48 (18-75 V)	±15 V @ 0.667 A	2" x 1" x 0.43" (50.8 x 25.4 x 11)	3000 Vac rms	86%	ERM01CC36
	72, 110 (40-160 V)	5 V @ 4 A	2" x 1" x 0.43" (50.8 x 25.4 x 11)	3000 Vac rms	83%	ERM04A110
	72, 110 (40-160 V)	12 V @ 1.67 A	2" x 1" x 0.43" (50.8 x 25.4 x 11)	3000 Vac rms	86%	ERM01B110
	72, 110 (40-160 V)	15 V @ 1.33 A	2" x 1" x 0.43" (50.8 x 25.4 x 11)	3000 Vac rms	86%	ERM01C110
72, 110 (40-160 V)	24 V @ 0.833 A	2" x 1" x 0.43" (50.8 x 25.4 x 11)	3000 Vac rms	85%	ERM01H110	
72, 110 (40-160 V)	±12 V @ 0.833 A	2" x 1" x 0.43" (50.8 x 25.4 x 11)	3000 Vac rms	86%	ERM01BB110	
72, 110 (40-160 V)	±15 V @ 0.667 A	2" x 1" x 0.43" (50.8 x 25.4 x 11)	3000 Vac rms	86%	ERM01CC110	
40 W	36-160 V	5 V @ 8 A	2" x 1" x 0.43" (50.8 x 25.4 x 11)	3000 Vac rms	88%	ERM08A100
	36-160 V	12 V @ 3.33 A	2" x 1" x 0.43" (50.8 x 25.4 x 11)	3000 Vac rms	89%	ERM03B100
	36-160 V	15 V @ 2.67 A	2" x 1" x 0.43" (50.8 x 25.4 x 11)	3000 Vac rms	89%	ERM02C100
	36-160 V	24 V @ 1.67 A	2" x 1" x 0.43" (50.8 x 25.4 x 11)	3000 Vac rms	89%	ERM01H100
	36-160 V	54 V @ 0.741 A	2" x 1" x 0.43" (50.8 x 25.4 x 11)	3000 Vac rms	90%	ERM01U100
	36-160 V	±12V @ 1.67 A	2" x 1" x 0.43" (50.8 x 25.4 x 11)	3000 Vac rms	89%	ERM02BB100
	36-160 V	±15V @ 1.33 A	2" x 1" x 0.43" (50.8 x 25.4 x 11)	3000 Vac rms	89%	ERM02CC100

	Input Voltage	Output	Package	I/O Isolation	Efficiency	Model Number
50 W	72 (43-101 V)	5 V @ 10 A	2.28" x 1.45" x 0.5" (57.9 x 36.8 x 12.7)	3000 Vac rms	90%	ERM10A72
	72 (43-101 V)	12 V @ 4.17 A	2.28" x 1.45" x 0.5" (57.9 x 36.8 x 12.7)	3000 Vac rms	92%	ERM04B72
	72 (43-101 V)	15 V @ 3.33 A	2.28" x 1.45" x 0.5" (57.9 x 36.8 x 12.7)	3000 Vac rms	92%	ERM03C72
	72 (43-101 V)	24 V @ 2.08 A	2.28" x 1.45" x 0.5" (57.9 x 36.8 x 12.7)	3000 Vac rms	91%	ERM02H72
	110 (66-160 V)	5 V @ 10 A	2.28" x 1.45" x 0.5" (57.9 x 36.8 x 12.7)	3000 Vac rms	90%	ERM10A110
	110 (66-160 V)	12 V @ 4.17 A	2.28" x 1.45" x 0.5" (57.9 x 36.8 x 12.7)	3000 Vac rms	91%	ERM04B110
	110 (66-160 V)	15 V @ 3.33 A	2.28" x 1.45" x 0.5" (57.9 x 36.8 x 12.7)	3000 Vac rms	92%	ERM03C110
	110 (66-160 V)	24 V @ 2.08 A	2.28" x 1.45" x 0.5" (57.9 x 36.8 x 12.7)	3000 Vac rms	91%	ERM02H110
75 W	72 (43-101 V)	5 V @ 15 A	2.28" x 1.45" x 0.5" (57.9 x 36.8 x 12.7)	3000 Vac rms	89%	ERM15A72
	72 (43-101 V)	12 V @ 6.25 A	2.28" x 1.45" x 0.5" (57.9 x 36.8 x 12.7)	3000 Vac rms	92%	ERM06B72
	72 (43-101 V)	15 V @ 5 A	2.28" x 1.45" x 0.5" (57.9 x 36.8 x 12.7)	3000 Vac rms	92%	ERM05C72
	72 (43-101 V)	24 V @ 3.125 A	2.28" x 1.45" x 0.5" (57.9 x 36.8 x 12.7)	3000 Vac rms	91%	ERM03H72
	110 (66-160 V)	5 V @ 15 A	2.28" x 1.45" x 0.5" (57.9 x 36.8 x 12.7)	3000 Vac rms	89%	ERM15A110
	110 (66-160 V)	12 V @ 6.25 A	2.28" x 1.45" x 0.5" (57.9 x 36.8 x 12.7)	3000 Vac rms	91%	ERM06B110
	110 (66-160 V)	15 V @ 5 A	2.28" x 1.45" x 0.5" (57.9 x 36.8 x 12.7)	3000 Vac rms	91%	ERM05C110
	110 (66-160 V)	24 V @ 3.125 A	2.28" x 1.45" x 0.5" (57.9 x 36.8 x 12.7)	3000 Vac rms	90%	ERM03H110

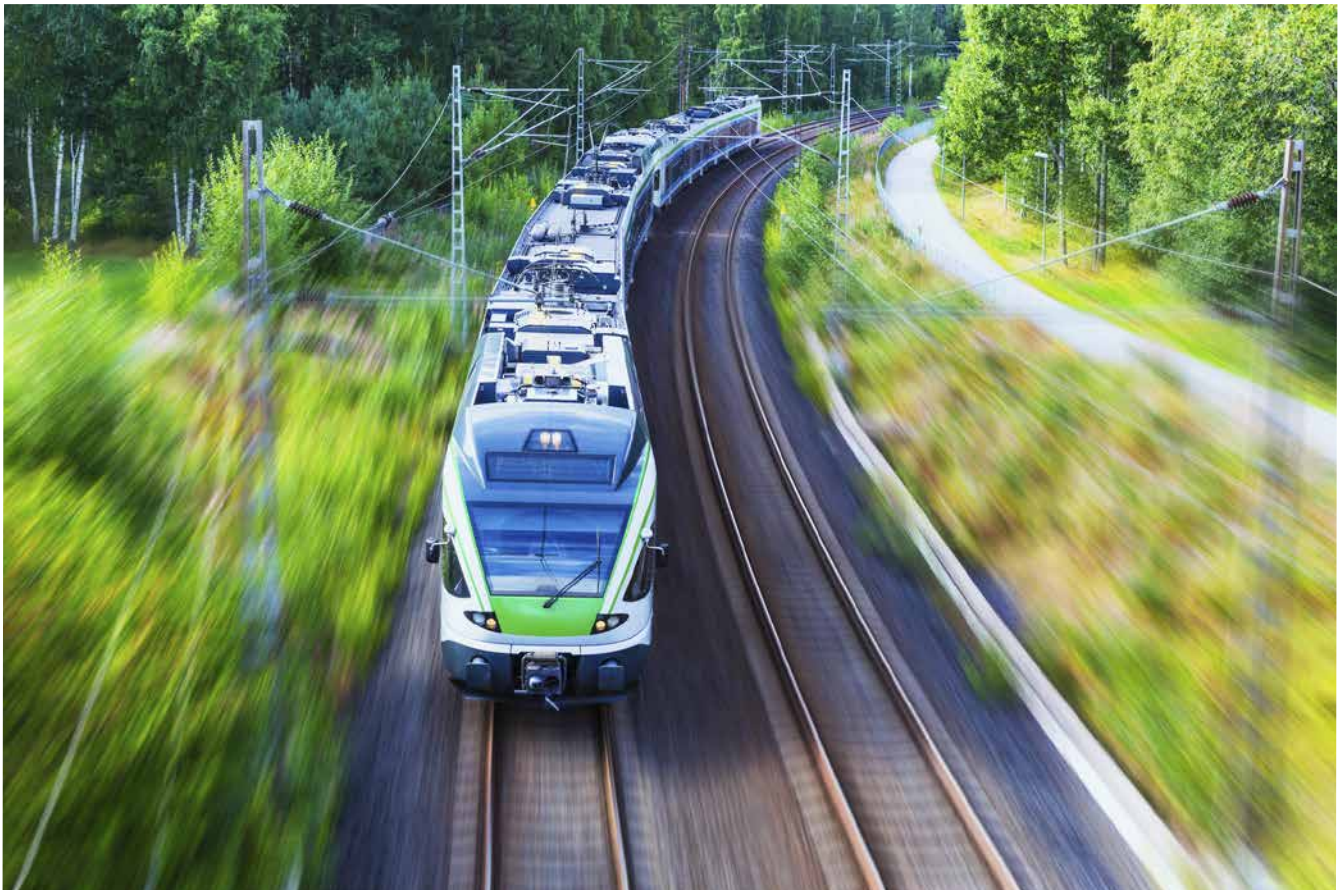

DC-DC Converter for Medical Application



Special Features

Medical Safety to UL / CSA / IEC / EN 60601-1 3rd Edition

- 4200 VAC reinforced insulation
- 2 MOOP rated
- Low leakage current
- Operating Temperature Range -40 °C to +85 °C (with derating)
- Input filter meet EN 55022, Class A and FCC, Level A
- 3 years product warranty

	Input Voltage	Output 1 Voltage	Output 2 Voltage	Package L x W x H (mm)	I/O Isolation	Efficiency	Model Number
5 W	Enclosed						
	9-18 V	5 V @ 1 A		1.25" x 0.8" x 0.41" (31.8 x 20.3 x 10.5)	4200 VACrms	75%	ASA01A12-M
	18-36 V	5 V @ 1 A		1.25" x 0.8" x 0.41" (31.8 x 20.3 x 10.5)	4200 VACrms	77%	ASA01A24-M
	36-75 V	5 V @ 1 A		1.25" x 0.8" x 0.41" (31.8 x 20.3 x 10.5)	4200 VACrms	77%	ASA01A48-M
6 W	Enclosed						
	9-18 V	12 V @ 0.5 A		1.25" x 0.8" x 0.41" (31.8 x 20.3 x 10.5)	4200 VACrms	78%	ASA01B12-M
	9-18 V	12 V @ 0.25 A		1.25" x 0.8" x 0.41" (31.8 x 20.3 x 10.5)	4200 VACrms	78%	ASA01BB12-M
	9-18 V	15 V @ 0.2 A		1.25" x 0.8" x 0.41" (31.8 x 20.3 x 10.5)	4200 VACrms	78%	ASA01CC12-M
	18-36 V	12 V @ 0.5 A		1.25" x 0.8" x 0.41" (31.8 x 20.3 x 10.5)	4200 VACrms	80%	ASA01B24-M
	18-36 V	12 V @ 0.25 A		1.25" x 0.8" x 0.41" (31.8 x 20.3 x 10.5)	4200 VACrms	80%	ASA01BB24-M
	18-36 V	15 V @ 0.2 A		1.25" x 0.8" x 0.41" (31.8 x 20.3 x 10.5)	4200 VACrms	80%	ASA01CC24-M
	36-75 V	12 V @ 0.5 A		1.25" x 0.8" x 0.41" (31.8 x 20.3 x 10.5)	4200 VACrms	80%	ASA01B48-M
	36-75 V	12 V @ 0.25 A		1.25" x 0.8" x 0.41" (31.8 x 20.3 x 10.5)	4200 VACrms	80%	ASA01BB48-M
	36-75 V	15 V @ 0.2 A		1.25" x 0.8" x 0.41" (31.8 x 20.3 x 10.5)	4200 VACrms	80%	ASA01CC48-M
8 W 10 W	9-18 V	5 V @ 1.6 A		2" x 1" x 0.4" (50.8 x 25.4 x 10.2)	4200 VACrms	76%	AEE01A12-M
	9-18 V	12 V @ 0.835 A		2" x 1" x 0.4" (50.8 x 25.4 x 10.2)	4200 VACrms	80%	AEE00B12-M
	9-18 V	12 V @ 0.417 A	-12 V @ 0.417 A	2" x 1" x 0.4" (50.8 x 25.4 x 10.2)	4200 VACrms	80%	AEE00BB12-M
	9-18 V	15 V @ 0.333 A	-15 V @ 0.333 A	2" x 1" x 0.4" (50.8 x 25.4 x 10.2)	4200 VACrms	81%	AEE00CC12-M
	18-36 V	5 V @ 2 A		2" x 1" x 0.4" (50.8 x 25.4 x 10.2)	4200 VACrms	77%	AEE02A24-M
	18-36 V	12 V @ 0.835 A		2" x 1" x 0.4" (50.8 x 25.4 x 10.2)	4200 VACrms	81%	AEE00B24-M
	18-36 V	12 V @ 0.417 A	-12 V @ 0.417 A	2" x 1" x 0.4" (50.8 x 25.4 x 10.2)	4200 VACrms	81%	AEE00BB24-M
	18-36 V	15 V @ 0.333 A	-15 V @ 0.333 A	2" x 1" x 0.4" (50.8 x 25.4 x 10.2)	4200 VACrms	82%	AEE00CC24-M
	36-75 V	5 V @ 2 A		2" x 1" x 0.4" (50.8 x 25.4 x 10.2)	4200 VACrms	77%	AEE02A48-M
	36-75 V	12 V @ 0.835 A		2" x 1" x 0.4" (50.8 x 25.4 x 10.2)	4200 VACrms	81%	AEE00B48-M
	36-75 V	12 V @ 0.417 A	-12 V @ 0.417 A	2" x 1" x 0.4" (50.8 x 25.4 x 10.2)	4200 VACrms	81%	AEE00BB48-M
	36-75 V	15 V @ 0.333 A	-15 V @ 0.333 A	2" x 1" x 0.4" (50.8 x 25.4 x 10.2)	4200 VACrms	82%	AEE00CC48-M



DC-DC Converter for Medical Application

Medical Safety to UL / CSA / IEC / EN 60601-1 3rd Edition



	Input Voltage	Output 1 Voltage	Output 2 Voltage	Package L x W x H (mm)	I/O Isolation	Efficiency	Model Number
15 W	Enclosed						
	9-18 V	5 V @ 3 A		2" x 1" x 0.47" (50.8 x 25.4 x 12)	4200 VACrms	85%	AEE03A12-M
	9-18 V	12 V @ 1.25 A		2" x 1" x 0.47" (50.8 x 25.4 x 12)	4200 VACrms	89%	AEE01B12-M
	9-18 V	15 V @ 1 A		2" x 1" x 0.47" (50.8 x 25.4 x 12)	4200 VACrms	88%	AEE01C12-M
	9-18 V	24 V @ 0.625 A		2" x 1" x 0.47" (50.8 x 25.4 x 12)	4200 VACrms	88%	AEE01H12-M
	9-18 V	12 V @ 0.625 A	-12 V @ 0.625 A	2" x 1" x 0.47" (50.8 x 25.4 x 12)	4200 VACrms	88%	AEE01BB12-M
	9-18 V	15 V @ 0.5 A	-15 V @ 0.5 A	2" x 1" x 0.47" (50.8 x 25.4 x 12)	4200 VACrms	89%	AEE01CC12-M
	18-36 V	5 V @ 3 A		2" x 1" x 0.47" (50.8 x 25.4 x 12)	4200 VACrms	87%	AEE03A24-M
	18-36 V	12 V @ 1.25 A		2" x 1" x 0.47" (50.8 x 25.4 x 12)	4200 VACrms	89%	AEE01B24-M
	18-36 V	15 V @ 1 A		2" x 1" x 0.47" (50.8 x 25.4 x 12)	4200 VACrms	88%	AEE01C24-M
	18-36 V	24 V @ 0.625 A		2" x 1" x 0.47" (50.8 x 25.4 x 12)	4200 VACrms	90%	AEE01H24-M
	18-36 V	12 V @ 0.625 A	-12 V @ 0.625 A	2" x 1" x 0.47" (50.8 x 25.4 x 12)	4200 VACrms	90%	AEE01BB24-M
	18-36 V	15 V @ 0.5 A	-15 V @ 0.5 A	2" x 1" x 0.47" (50.8 x 25.4 x 12)	4200 VACrms	89%	AEE01CC24-M
	36-75 V	5 V @ 3 A		2" x 1" x 0.47" (50.8 x 25.4 x 12)	4200 VACrms	88%	AEE03A48-M
	36-75 V	12 V @ 1.25 A		2" x 1" x 0.47" (50.8 x 25.4 x 12)	4200 VACrms	88%	AEE01B48-M
	36-75 V	15 V @ 1 A		2" x 1" x 0.47" (50.8 x 25.4 x 12)	4200 VACrms	87%	AEE01C48-M
	36-75 V	24 V @ 0.625 A		2" x 1" x 0.47" (50.8 x 25.4 x 12)	4200 VACrms	88%	AEE01H48-M
	36-75 V	12 V @ 0.625 A	-12 V @ 0.625 A	2" x 1" x 0.47" (50.8 x 25.4 x 12)	4200 VACrms	88%	AEE01BB48-M
36-75 V	15 V @ 0.5 A	-15 V @ 0.5 A	2" x 1" x 0.47" (50.8 x 25.4 x 12)	4200 VACrms	88%	AEE01CC48-M	
20 W	9-18 V	5 V @ 4 A		2" x 1" x 0.47" (50.8 x 25.4 x 12)	4200 VACrms	85%	AEE04A12-M
	9-18 V	12 V @ 1.67 A		2" x 1" x 0.47" (50.8 x 25.4 x 12)	4200 VACrms	89%	AEE02B12-M
	9-18 V	15 V @ 1.33 A		2" x 1" x 0.47" (50.8 x 25.4 x 12)	4200 VACrms	88%	AEE02C12-M
	9-18 V	24 V @ 0.84 A		2" x 1" x 0.47" (50.8 x 25.4 x 12)	4200 VACrms	89%	AEE02H12-M
	9-18 V	12 V @ 0.84 A	-12 V @ 0.84 A	2" x 1" x 0.47" (50.8 x 25.4 x 12)	4200 VACrms	89%	AEE02BB12-M
	9-18 V	15 V @ 0.67 A	-15 V @ 0.67 A	2" x 1" x 0.47" (50.8 x 25.4 x 12)	4200 VACrms	89%	AEE02CC12-M
	18-36 V	5 V @ 4 A		2" x 1" x 0.47" (50.8 x 25.4 x 12)	4200 VACrms	87%	AEE04A24-M
	18-36 V	12 V @ 1.67 A		2" x 1" x 0.47" (50.8 x 25.4 x 12)	4200 VACrms	89%	AEE02B24-M
	18-36 V	15 V @ 1.33 A		2" x 1" x 0.47" (50.8 x 25.4 x 12)	4200 VACrms	88%	AEE02C24-M
	18-36 V	24 V @ 0.84 A		2" x 1" x 0.47" (50.8 x 25.4 x 12)	4200 VACrms	90%	AEE02H24-M
	18-36 V	12 V @ 0.84 A	-12 V @ 0.84 A	2" x 1" x 0.47" (50.8 x 25.4 x 12)	4200 VACrms	90%	AEE02BB24-M
	18-36 V	15 V @ 0.67 A	-15 V @ 0.67 A	2" x 1" x 0.47" (50.8 x 25.4 x 12)	4200 VACrms	89%	AEE02CC24-M
	36-75 V	5 V @ 4 A		2" x 1" x 0.47" (50.8 x 25.4 x 12)	4200 VACrms	88%	AEE04A48-M
	36-75 V	12 V @ 1.67 A		2" x 1" x 0.47" (50.8 x 25.4 x 12)	4200 VACrms	89%	AEE02B48-M
	36-75 V	15 V @ 1.33 A		2" x 1" x 0.47" (50.8 x 25.4 x 12)	4200 VACrms	88%	AEE02C48-M
	36-75 V	24 V @ 0.84 A		2" x 1" x 0.47" (50.8 x 25.4 x 12)	4200 VACrms	88%	AEE02H48-M
	36-75 V	12 V @ 0.84 A	-12 V @ 0.84 A	2" x 1" x 0.47" (50.8 x 25.4 x 12)	4200 VACrms	88%	AEE02BB48-M
	36-75 V	15 V @ 0.67 A	-15 V @ 0.67 A	2" x 1" x 0.47" (50.8 x 25.4 x 12)	4200 VACrms	89%	AEE02CC48-M



Rapid Modification and Value-Added Solutions

Why use a Modified Standard Power Supply?

Time-to-market, reliability and costs have the greatest impact on your ROI. Fully custom solutions can delay your time-to-market and undermine your competitive advantage. So why pay custom development costs when Artesyn can deliver a modified standard power supply sample the way you want it, delivered in days at a standard price.

Artesyn has you Covered!

No matter what type of power supply you need, Artesyn has you covered!

While Artesyn Embedded Power offers a broad range of standard products that address the needs of many industries, there are occasions when a standard product does not address all your application requirements. Also, a custom solution does not always make economic sense, especially in terms of your schedule needs. This is where the knowledge and expertise of Artesyn really pays dividends. By using proven standard platforms as building blocks, we can develop cost-effective turnkey power solutions that meet your exact needs.

- Sample lead time varies with complexity.

Rapid Modification

Simple to Complex Modifications – Initial Samples Can be Available in Days!

Value-Add & Changes Made

- Modified output termination from single to 3-way contact
- AC_OK and POK Logic and timing signal changes via firmware
- Custom enclosure and accessories
- Ruggedization for shock and vibration
- Firmware changes for heavy peak loading startup; and load adaptive fan speed.

Modified Advantage

What you will get from Artesyn's modified power supplies:

- Broad portfolio of power supplies to leverage from
- Quick time to market vs. custom solutions
- Low risk - using proven reliable platforms as building blocks
- Cost effective (Lower development cost)
- Quality, high reliability products



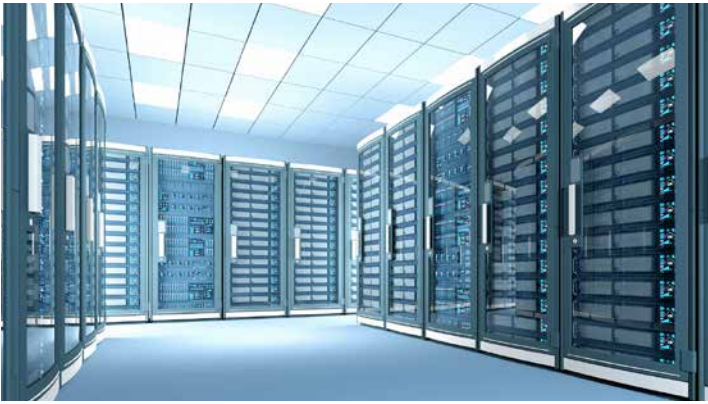

Modified Solutions

Artesyn provides modified standard products and value-add solutions in varying degrees of complexity. These meet specific customer needs in a wide range of applications, such as:



Communications

- Access Solutions
- Enterprise Networking
- Wireless Communications
- Wireline Communications
- Optical Communications



Healthcare

- Bio Life Sciences
- Dental
- Imaging
- Laboratory
- Medical



Industrial

- Process Control
- Robotics
- Test & Measurement

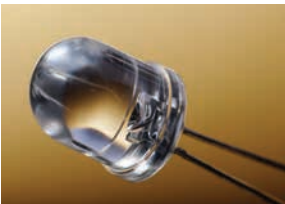

Lighting & Signage

- Displays
- Illuminated Signs



Mil/Aero (COTS)

- Avionics
- In-flight Entertainment

Capabilities

The exact specifications you require that's within your budget

Electrical Parameters



- Factory Vout Preset
- Low Noise
- Power & Efficiency Upgrades
- Hot Swap Control
- Inrush Current Control
- Integrated PDU Assemblies
- Compliance to Industry Standards

Connectivity



- Cable Wire Assemblies
- Connector Changes
- Busbar Design
- Overmoulding
- Interposer Boards

Packaging



- Conformal Coating
- Custom Chassis/Sled
- Ruggedization for Shock, Vibration and Hazardous Locations
- Shielding for High Magnetic Environment
- Sealed/IP Rated Enclosures
- Customized Print/Marking/Labels

Communications & Control



- Logic Signal/Timing Changes
- Adaptive Fan Control
- Output Sequencing
- Peak Load/Efficiency Optimization

Terms and Conditions of Sale

The Artesyn Embedded Technologies company that accepts Buyer's order for Goods is herein referred to as the "Seller" and the person or entity purchasing goods or services ("Goods") and/or licensing software and/or firmware which are preloaded, or to be loaded into Goods ("Software") from Seller is referred to as the "Buyer." These Terms and Conditions, together with any price list or schedule, quotation, acknowledgment or invoice from Seller relevant to the sale of the Goods and licensing of Software and all documents incorporated by specific reference herein or therein constitute the complete and exclusive statement of the terms governing the sale of Goods and license of Software by Seller to Buyer. Seller's acceptance of Buyer's purchase order is expressly conditional on Buyer's assent to all of Seller's terms and conditions of sale, including terms and conditions that are different from or additional to the terms and conditions of Buyer's purchase order, and Seller expressly rejects any additional or conflicting terms specified in Buyer's purchase order or any other document provided by Buyer. Buyer's acceptance of the Goods and/or Software will manifest Buyer's assent to these Terms and Conditions. Seller reserves the right in its sole discretion to refuse orders. Notwithstanding anything to the contrary, in the event that the provisions of these Terms and Conditions conflict with the provisions of an effective agreement signed by a duly authorized representative of both parties ("Effective Agreement") that applies to the transaction(s) contemplated herein, the Effective Agreement shall control.

1. **PRICES:** Unless otherwise specified in writing by Seller, the price quoted or specified by Seller for the Goods and/or Software shall remain in effect for 30 days after the date of Seller's quotation or acknowledgment of Buyer's order for the Goods and/or Software, whichever occurs first, provided an unconditional authorization from Buyer for the shipment of the Goods and/or Software is received and accepted by Seller within such time period. If such authorization is not received by Seller within such 30 day period, Seller shall have the right to change the price and other terms applicable to the Goods and/or Software to Seller's standard price and terms for the Goods and/or Software at the time of shipment. All prices and licensee fees are exclusive of taxes, transportation and insurance, which are to be borne by Buyer.

2. **TAXES:** Any current or future tax or governmental charge (or increase in same) affecting Seller's costs of production, sale, or shipment, or which Seller is otherwise required to pay or collect in connection with the sale, purchase, delivery, storage, processing, use or consumption of Goods and/or Software, shall be for Buyer's account and shall be added to the price or billed to Buyer separately, at Seller's election.

3. **TERMS OF PAYMENT:** Unless otherwise specified by Seller, terms are net 30 days from date of Seller's invoice by bank wire transfer or automated clearing house in U.S. currency. Seller shall have the right, among other remedies, either to terminate this agreement and/or any other agreements between Seller and Buyer, or to suspend further performance under this and/or other agreements with Buyer in the event Buyer fails to make any payment when due, which other agreements Buyer and Seller hereby amend accordingly. Buyer shall be liable for all expenses, including attorneys' fees, relating to the collection of past due amounts. If any payment owed to Seller is not paid when due, it shall bear interest, at a rate to be determined by Seller, which shall not exceed the maximum rate permitted by law, from the date on which it is due until it is paid. Any payment due to either party under this agreement shall be made in full without any set-off, restriction, condition deduction or withholding for or on account of any counterclaim. Should Buyer's financial responsibility become unsatisfactory to Seller, Seller may require Buyer to immediately pay in full all amounts due to Seller, and cash payments or security satisfactory to Seller may be required by Seller for future deliveries of the Goods and/or Software. If such cash payment or security is not provided, in addition to Seller's other rights and remedies, Seller may discontinue deliveries.

4. **SHIPMENT AND DELIVERY:** While Seller will use commercially reasonable efforts to maintain the delivery date(s) acknowledged or quoted by Seller, all shipping dates are approximate and not guaranteed. Seller reserves the right to make partial shipments. Seller, at its option, shall not be bound to tender delivery of any Goods and/or Software for which Buyer has not provided shipping instructions and other required information. If the shipment of the Goods and/or Software is postponed or delayed by Buyer for any reason, Buyer agrees to reimburse Seller for any and all storage costs and other additional expenses resulting therefrom. Risk of loss and

legal title to the Goods shall transfer from Seller to Buyer upon delivery to and receipt by carrier at Seller's shipping point. As permitted by local law, as collateral security for the payment of the purchase price of the Goods, Buyer hereby grants to Seller a lien on and security interest in and to all of the right, title and interest of Buyer in, to and under the Goods, wherever located, and whether now existing or hereafter arising or acquired from time to time, and in all accessions thereto and replacements or modifications thereof, as well as all proceeds (including insurance proceeds) of the foregoing. The security interest granted under this provision constitutes a purchase money security interest under applicable law. Unless otherwise specified by Seller, all shipments are F.C.A. Seller's shipping point (Incoterms 2010). Any claims for shortages or damages suffered in transit are the responsibility of Buyer and shall be submitted by Buyer directly to the carrier. Shortages or damages must be identified and signed for at the time of delivery.

Buyer shall inspect Goods delivered to it by Seller immediately upon receipt, and, any course of dealing to the contrary notwithstanding, failure of Buyer to give Seller notice of any claim within 10 days after receipt of such Goods shall be an unqualified acceptance of such Goods.

5. **LIMITED WARRANTY:** Subject to the limitations of Section 6 and unless otherwise specified by Seller in writing, Seller warrants that the Goods manufactured by Seller will be free from defects in material and workmanship and substantially meet Seller's published specifications at the time of shipment under normal use and regular service and maintenance for (a) the period specified in Seller's then current product data sheets from the date of manufacture by Seller in the case of standard Embedded Power Goods, and (b) the period, if any, specified by Seller in writing in the case of custom Embedded Power Goods. Services will be performed in a professional manner and in accordance with industry standards. Unless otherwise stated in writing in a separate Software license agreement or otherwise, Seller makes no warranty as to any Goods/Software. **THE WARRANTIES SET FORTH IN SECTIONS 5 AND 7 ARE THE SOLE AND EXCLUSIVE WARRANTIES GIVEN BY SELLER WITH RESPECT TO THE GOODS AND SOFTWARE AND ARE IN LIEU OF AND EXCLUDE ALL OTHER WARRANTIES, EXPRESS OR IMPLIED, ARISING BY OPERATION OF LAW OR OTHERWISE, INCLUDING WITHOUT LIMITATION, MERCHANTABILITY AND FITNESS FOR A PARTICULAR PURPOSE WHETHER OR NOT THE PURPOSE OR USE HAS BEEN DISCLOSED TO SELLER IN SPECIFICATIONS, DRAWINGS OR OTHERWISE, AND WHETHER OR NOT SELLER'S PRODUCTS ARE SPECIFICALLY DESIGNED AND/OR MANUFACTURED BY SELLER FOR BUYER'S USE OR PURPOSE.**

These warranties do not extend to any losses or damages due to misuse, accident, abuse, neglect, negligence (other than Seller's), unauthorized modification or alteration, use beyond rated capacity, unsuitable power sources or environmental conditions, improper installation, repair, handling, maintenance or application or any other cause not the fault of Seller. To the extent that Buyer or its agents have supplied specifications, information, representation of operating conditions or other data to Seller in the selection or design of the Goods and the preparation of Seller's quotation, and in the event that actual operating conditions or other conditions differ from those represented by Buyer, any warranties or other provisions contained herein that are affected by such conditions shall be null and void.

If within 30 days after Buyer's discovery of any warranty defects within the warranty period, Buyer notifies Seller thereof in writing, Seller shall, at its option and as Buyer's exclusive remedy, repair, correct or replace per its return policy, or refund the purchase price for, that portion of the Goods found by Seller to be defective. Failure by Buyer to give such written notice within the applicable time period shall be deemed an absolute and unconditional waiver of Buyer's claim for such defects. Advance written permission to return Goods must be obtained from Seller. Such Goods must be shipped transportation prepaid to Seller. Returns made without proper written permission will not be accepted by Seller. Seller reserves the right to inspect Goods prior to authorizing return. Goods repaired or replaced during the warranty period shall be covered by the foregoing warranties for the remainder of the original warranty period or 90 days from the date of shipment, whichever is longer.

Buyer assumes all other responsibility for any loss, damage, or injury to persons or property arising out of, connected with, or resulting from the use of Goods and/or Software, either alone or in combination with other products/components.

PRE-PRODUCTION (Prototype, Engineering Verification Test, or Design Verification Test) UNITS ARE SOLD "WHERE IS, AS IS, WITH ALL FAULTS" WITHOUT WARRANTY OF ANY KIND, EXPRESS OR IMPLIED, INCLUDING, WITHOUT LIMITATION, IMPLIED WARRANTIES OF MERCHANTABILITY OR FITNESS FOR INTENDED PURPOSE.

6. LIMITATION OF REMEDY AND LIABILITY: OTHER THAN WITH RESPECT TO THE PATENT AND COPYRIGHT WARRANTY PROVIDED UNDER SECTION 7 (FOR WHICH THE EXCLUSIVE REMEDIES ARE THOSE EXPRESSLY SET FORTH IN THAT SECTION), BUYER'S SOLE AND EXCLUSIVE REMEDY RELATING TO THIS AGREEMENT OR ANY GOODS OR SOFTWARE PROVIDED HEREUNDER, WHETHER ARISING UNDER CONTRACT, TORT, OR ANY OTHER THEORY OF LIABILITY, SHALL BE LIMITED TO REPAIR, CORRECTION OR REPLACEMENT, OR REFUND OF THE PURCHASE PRICE UNDER SECTION 5.

SELLER SHALL NOT BE LIABLE FOR DAMAGES CAUSED BY DELAY IN PERFORMANCE AND THE REMEDIES OF BUYER SET FORTH IN THIS AGREEMENT ARE EXCLUSIVE. EXCEPT FOR DAMAGES ARISING FROM DEATH, BODILY INJURY OR PROPERTY DAMAGE, IN NO EVENT, REGARDLESS OF THE FORM OF THE CLAIM OR CAUSE OF ACTION (WHETHER BASED IN CONTRACT, INFRINGEMENT, NEGLIGENCE, STRICT LIABILITY, OTHER TORT OR OTHERWISE), SHALL SELLER'S LIABILITY TO BUYER AND/OR ITS CUSTOMERS FOR ANY DIRECT DAMAGES OF ANY VARIETY (INCLUDING ANY BREACH OF SECTION 19 BELOW) EXCEED THE PRICE PAID BY BUYER FOR THE SPECIFIC GOODS OR SOFTWARE PROVIDED BY SELLER GIVING RISE TO THE CLAIM OR CAUSE OF ACTION. BUYER AGREES THAT IN NO EVENT SHALL SELLER'S LIABILITY TO BUYER AND/OR ITS CUSTOMERS EXTEND TO INCLUDE INCIDENTAL, CONSEQUENTIAL OR PUNITIVE DAMAGES. The term "consequential damages" shall include, but not be limited to, loss of anticipated profits, business interruption, loss of use, revenue, reputation and data, costs of procurement of substitute goods or services, costs incurred, including without limitation, for capital, fuel, power, cover and loss or damage to property or equipment.

It is expressly understood that any technical advice furnished by Seller with respect to the use of the Goods and/or Software is given without charge, and Seller assumes no obligation or liability for the advice given, or results obtained, all such advice being given and accepted at Buyer's risk.

7. PATENTS AND COPYRIGHTS: Subject to the limitations of the second paragraph of Section 6, Seller warrants that the Goods sold, except as are made specifically for Buyer according to Buyer's specifications, do not infringe any valid U.S. patent or copyright in existence as of the date of shipment. This warranty is given upon the condition that Buyer promptly notifies Seller of any claim or suit involving Buyer in which such infringement is alleged and cooperates fully with Seller and permits Seller to control completely the defense, settlement or compromise of any such allegation of infringement. Seller's warranty as to utility patents only applies to infringement arising solely out of the inherent operation according to Seller's specifications and instructions of such Goods. In the event such Goods are held to infringe such a U.S. patent or copyright in such suit, and / or the use of such Goods is enjoined, or in the case of a compromise or settlement by Seller, Seller shall have the right, at its option and expense and as Buyer's sole and exclusive remedy for a violation of the warranty contained in this Section, to procure for Buyer the right to continue using such Goods, or replace them with non-infringing Goods, or modify same to become non-infringing, or grant Buyer a credit for the depreciated value of such Goods and accept return of them. In the event of the foregoing or, if in Seller's opinion, Seller receives a credible allegation of infringement, Seller may also, at its option, cancel or suspend this agreement as to future deliveries of such Goods, without liability.

8. EXCUSE OF PERFORMANCE: Seller shall not be liable for delays in performance or for non-performance due to acts of God; acts of Buyer; war; fire; flood; weather; sabotage; epidemics; strikes or labor disputes; civil disturbances or riots; governmental requests, restrictions, allocations, laws, regulations, orders or actions; unavailability of or delays in transportation; restrictions, allocations or disruption of suppliers or default of suppliers; or unforeseen circumstances or any events or causes beyond Seller's reasonable control. Deliveries or other performance may be suspended for an appropriate period of time or canceled by Seller upon notice to Buyer in the event of any of the foregoing, but the balance of the agreement shall otherwise remain unaffected as a result of the foregoing.

If Seller determines that its ability to supply the total demand for the Goods, or to obtain material used directly or indirectly in the manufacture of the Goods, is hindered, limited or made impracticable due to causes set forth in the preceding paragraph, Seller may allocate its available supply of the Goods or such material (without obligation to acquire other supplies of any such Goods or material) among its purchasers on such basis as Seller determines to be equitable without liability for any failure of performance which may result therefrom.

9. RESCHEDULE/CANCELLATION: Unless otherwise agreed in writing by Seller, orders under this agreement may not be rescheduled or canceled by Buyer for any reason.

10. CHANGES: Buyer may request changes or additions to the Goods and/or Software consistent with Seller's specifications and criteria. In the event such changes or additions are accepted by Seller, Seller may revise the price, license fees and dates of delivery.

Seller reserves the right to change designs and specifications for the Goods and/or Software without prior notice to Buyer, except with respect to Goods and/or Software being made to order for Buyer. Seller shall have no obligation to install or make such change in any Goods and/or Software manufactured prior to the date of such change.

11. NUCLEAR/MEDICAL: GOODS AND SOFTWARE SOLD HEREUNDER ARE NOT FOR USE IN CONNECTION WITH ANY NUCLEAR, MEDICAL, LIFE-SUPPORT, AIRCRAFT CONTROL, AND OTHER HIGH RISK APPLICATIONS WHERE GOODS OR SOFTWARE FAILURE COULD LEAD TO LOSS OF LIFE OR CATASTROPHIC PROPERTY DAMAGE. Buyer accepts Goods and Software with the foregoing understanding, agrees to communicate the same in writing to any subsequent purchasers or users and to defend, indemnify and hold harmless Seller from any claims, losses, suits, judgments and damages, including incidental and consequential damages, arising from such use, whether the cause of action be based in tort, contract or otherwise, including allegations that the Seller's liability is based on negligence or strict liability.

12. ASSIGNMENT: Buyer shall not assign its rights or delegate its duties hereunder or any interest herein without the prior written consent of Seller, and any such assignment, without such consent, shall be void.

13. SOFTWARE: Notwithstanding any other provision herein to the contrary, Seller or applicable third party licensor to Seller shall retain all rights of ownership and title in its respective Software, including without limitation all rights of ownership and title in its respective copies of such Software. Except as otherwise provided herein, Buyer is hereby granted a nonexclusive, non-transferable royalty free license to use the Software incorporated into the Goods solely for purposes of Buyer properly utilizing such Goods purchased from Seller. All other Software shall be furnished to, and used by, Buyer only after execution of Seller's (or the licensor's) applicable standard license agreement, the terms of which are incorporated herein by reference. The Software is Seller's own or Seller's supplier's proprietary information, and Buyer and its employees and agents shall not disclose the Software or any part thereof to others without Seller's prior written consent.

14. **TOOLING:** Tool, die, and pattern charges, if any, are in addition to the price of the Goods and are due and payable upon completion of the tooling. All such tools, dies and patterns shall be and remain the property of Seller. Charges for tools, dies, and patterns do not convey to Buyer, title, ownership interest in, or rights to possession or removal, or prevent their use by Seller for other purchasers, except as otherwise expressly provided by Seller and Buyer in writing with reference to this provision.

15. **INTELLECTUAL PROPERTY:** Seller's intellectual property, including without limitation, all patents, copyrights, trade secrets, trade-dress and any other intellectual property of any kind (including without limitation, that which exists in the underlying technology), furnished by or on behalf of Seller in connection with this agreement is the property of Seller and Seller retains all rights, including without limitation, exclusive rights of use, licensing, and sale. Possession of Goods, pre-production units, specifications, prints or drawings, or any other materials does not convey to Buyer any rights or license thereto.

16. **BUYER'S COMPLIANCE WITH LAWS:** In connection with the transactions contemplated by this agreement, Buyer is familiar with and shall fully comply with all applicable laws, regulations, rules and other requirements of the United States and of any applicable state, foreign and local governmental body in connection with the purchase, license, receipt, use, transfer and disposal of the Goods and/or Software.

17. **EXPORT/IMPORT:** Buyer agrees that all applicable import and export control laws, regulations, orders and requirements, including without limitation those of the United States and the European Union, and the jurisdictions in which the Seller and Buyer are established or from which Goods and/or Software may be supplied, will apply to their receipt and use. In no event shall Buyer use, transfer, release, import, export, Goods and/or Software in violation of such applicable laws, regulations, orders or requirements.

18. **GOVERNMENT CONTRACT CONDITIONS:** In the event Buyer supplies Goods or Software to the U.S. Government or to a prime contractor selling to the U.S. Government, the following Federal Acquisition Regulation (FAR) clauses are accepted by Seller and are made part of this agreement applicable to such supply: 52.222-21 Prohibition of Segregated Facilities; 52.222-26 Equal Opportunity; 52.222-35 Equal Opportunity For Special Disabled Veterans, Veterans of Vietnam Era, and Other Eligible Veterans; 52.222-36 Affirmative Action For Workers with Disabilities; and 52.219-8 Utilization of Small Business Concerns. No additional FAR or FAR Supplement clauses are accepted by Seller. In the event Buyer elects to sell Goods or Software to the U.S. Government or any national, state, provincial or local non-U.S. governmental entity or to a prime contractor selling to such entities, Buyer does so solely at its own option and risk, and agrees not to obligate Seller as a subcontractor or otherwise to the U.S. Government or other governmental entity except as described in this Section 18. Buyer remains solely and exclusively responsible for compliance with all statutes and regulations governing sales to the U.S. Government or any national, state, provincial or local non-U.S. governmental entity. Seller makes no representations, certifications or warranties whatsoever with respect to the ability of its Goods, Software, or prices to satisfy any such statutes and regulations.

19. **CONFIDENTIALITY:** All non-public, confidential or proprietary information of a party that (i) is marked as "confidential" or "proprietary" or (ii) is reasonably understood to be confidential or proprietary given the content of the information and the circumstances of disclosure ("Confidential Information"). Each party (as a "Receiving Party") shall (a) hold all Confidential Information of the other party (as the "Disclosing Party") in strict confidence; (b) not disclose Disclosing Party's Confidential Information to any third party without express prior written approval from Disclosing Party; (c) disclose Disclosing Party's Confidential Information only to such of its employees as actually require knowledge thereof in order to carry out their duties and are bound by confidentiality obligations at least as protective as the provisions contained in this agreement; and (d) use Disclosing Party's Confidential Information only for the purpose of performing its obligations hereunder. Upon Disclosing Party's request, Receiving Party shall promptly return all Confidential Information to Disclosing Party, as well as all documents and other materials incorporating any Disclosing Party Confidential Information. Disclosing Party shall be entitled to injunctive relief for any violation of this Section without the necessity of posting bond. This Section does not

apply to information that is: (x) freely available in the public domain; (y) known to Receiving Party at the time of disclosure without any obligation of confidentiality; or (z) rightfully obtained by Receiving Party on a non-confidential basis from a third party. The obligations of this provision shall continue as to each piece of Confidential Information for a period of three (3) years following the date of disclosure of such Confidential Information, except as to Confidential Information that constitutes a trade secret under applicable law and is expressly identified as a trade secret in writing, in which case the foregoing obligations shall continue in perpetuity. In the event the parties have separately entered into a separate Non-Disclosure Agreement, the terms of such separate Non-Disclosure Agreement shall supersede this provision.

20. **GENERAL PROVISIONS:** These terms and conditions supersede all other communications, negotiations and prior oral or written statements regarding the subject matter of these terms and conditions. No change, modification, rescission, discharge, abandonment, or waiver of these terms and conditions shall be binding upon the Seller unless made in writing and signed on its behalf by a duly authorized representative of Seller. No conditions, usage of trade, course of dealing or performance, understanding or agreement purporting to modify, vary, explain, or supplement these terms and conditions shall be binding unless hereafter made in writing and signed by the party to be bound, and no modification or additional terms shall be applicable to this agreement by Seller's receipt, acknowledgment, or acceptance of purchase orders, shipping instruction forms, or other documentation containing terms at variance with or in addition to those set forth herein. Any such modifications or additional terms are specifically rejected and deemed a material alteration hereof. If this document shall be deemed an acceptance of a prior offer by Buyer, such acceptance is expressly conditional upon Buyer's assent to any additional or different terms set forth herein. No waiver by either party with respect to any breach or default or of any right or remedy, and no course of dealing, shall be deemed to constitute a continuing waiver of any other breach or default or of any other right or remedy, unless such waiver be expressed in writing and signed by the party to be bound. All typographical or clerical errors made by Seller in any quotation, acknowledgment or publication are subject to correction. In the event that any provision or portion thereof contained in this agreement is held to be unenforceable, this agreement shall be construed without such provision or portion thereof. Provisions of this agreement which by their nature should apply beyond the termination of this agreement shall survive any such termination and will remain in full force and effect, including, but not limited to, Sections 6 (Limitation of Remedy and Liability), 11 (Nuclear/Medical), 12 (Assignment), 13 (Software), 14 (Tooling), 15 (Intellectual Property), 17 (Export/Import), 19 (Confidentiality), 20 and 21 (General Provisions).

(A) If Seller is a U.S. incorporated entity: This agreement shall be governed by the laws of the State of Delaware, U.S.A., without reference to its choice or conflict of laws principles. The parties agree to submit to the exclusive jurisdiction of the courts of the State of Delaware for all actions arising in connection herewith.

(B) If Seller is a European incorporated entity: This agreement shall be governed by the laws of England. Any dispute arising out of or in connection with this agreement that cannot be resolved through friendly consultation shall be referred to and finally resolved by arbitration in London, England before the London Court of International Arbitration in accordance with its arbitration rules. The arbitral award shall be final and binding on the parties.

(C) If Seller is an entity incorporated in the Asia Pacific region: This agreement shall be governed by the laws of the Hong Kong Special Administrative Region of the People's Republic of China. Any dispute arising out of or in connection with this agreement that cannot be resolved through friendly consultation shall be referred to and finally resolved by arbitration in Hong Kong before the Hong Kong International Arbitration Centre in accordance with its arbitration rules. The arbitral award shall be final and binding on the parties.

(D) No action, regardless of form, arising out of transactions relating to this agreement, may be brought by either party more than two (2) years after the cause of action has accrued. The U.N. Convention on Contracts for the International Sales of Goods shall not apply to this agreement.

Revised September 24, 2019

Technology Index

Section	Page	Section	Page	Section	Page
Low Power		Intelligent Medium Power		Industry Standard Non-Isolated	
CNS	12, 15, 16	iMP	29, 30, 31	LDO	73
CPS	12, 13, 14			LGA	74
LCC	17, 18, 19	Intelligent High Power		PTH	76
LPQ	11	iVS	32, 33, 34	PTV	76
LPS	9, 10, 11, 12	Precision High Power System		SIL	73, 75
LPT	9, 10, 12	iHP	35, 36, 37	SMT	73, 75
NLP	10, 12	Bulk Power		High Power	
NPS	9, 10	HPR	49	AIF	79
TLP	11	HPS	48, 49	AIH	79
External Power		LCM	38-47	AIQ	79
AD	21	UFE	48-50	AIT	79
DA	20, 21	Distributed Power		Low Power DC-DC Product	
DP	21	CSU	58	AEE	82, 85, 88, 89
Medical Power		CSV	59	AET	84, 85
CNS	24	DS	51-57	ASA	82, 83, 88
CPS	24	Din Rail		ATA	81, 82, 83
DA	26	ADN	63, 64	AXA	83, 84
DP	26	Industry Standard Isolated		AYA	80, 81
iHP	25	ADC	72	DC-DC Converter for Railway Application	
iMP	25	ADO	69, 77	ERM	86, 87
iVS	25	ADQ	70, 77		
LCC	24	AEO	69		
LCM	25	AGF	71		
LPQ	24	AGQ	70		
LPS	22, 23, 24	ALD	67, 68		
LPT	22, 23	ALO	69		
NLP	23	AVD	67, 68		
NPS	22, 23	AVE	71		
TLP	23	AVO	68, 69, 71		
μMP	25	AVQ	70, 72		
Micro Medium Power		BCQ	70		
μMP	27, 28	BDQ	70		

About Artesyn Embedded Power

Artesyn Embedded Power, an Advanced Energy company, is a global leader in the design and manufacture of highly reliable power conversion solutions for a wide range of industries including communications, computing, server storage, healthcare and industrial. For more than 40 years, customers have trusted Artesyn to help them accelerate time-to-market and reduce risk with cost-effective power conversion solutions. Artesyn has over 8,000 employees worldwide across multiple engineering centers of excellence, wholly-owned world-class manufacturing facilities, and global sales and support offices. Artesyn Embedded Power is a registered, assumed name of Artesyn Embedded Technologies, Inc., an Advanced Energy company.

About Advanced Energy

Advanced Energy (Nasdaq: AEIS) is a global leader in the design and manufacturing of highly engineered, precision power conversion, measurement and control solutions for mission-critical applications and processes. AE's power solutions enable customer innovation in complex applications for a wide range of industries including semiconductor equipment, industrial manufacturing, telecommunications, data center computing server storage and healthcare. With engineering know-how and responsive service and support around the globe, the company builds collaborative partnerships to meet technology advances, propel growth for its customers and innovate the future of power. Advanced Energy has devoted more than three decades to perfecting power for its global customers and is headquartered in Fort Collins, Colorado, USA. For more information, visit www.advancedenergy.com.

Advanced Energy | Precision. Power. Performance.

WORLDWIDE OFFICES

Americas

2900 South Diablo Way
Suite B100
Tempe, AZ 85282, USA
+1 888 412 7832

Europe (UK)

Ground Floor Offices, Barberry
House
4 Harbour Buildings, Waterfront
West Brierley Hill, West Midlands
DY5 1LN, UK
+44 (0) 1384 842 211

Asia (HK)

14/F, Lu Plaza
2 Wing Yip Street
Kwun Tong, Kowloon
Hong Kong
+852 2176 3333

Artesyn Embedded Technologies, Artesyn Embedded Power, Artesyn, and all Artesyn related logos are trademarks and service marks of Artesyn Embedded Technologies, Inc. All other names and logos referred to are trade names, trademarks, or registered trademarks of their respective owners. Specifications are subject to change without notice. © 2020 Artesyn Embedded Technologies, Inc. All rights reserved. For full legal terms and conditions, please visit www.artesyn.com/legal.

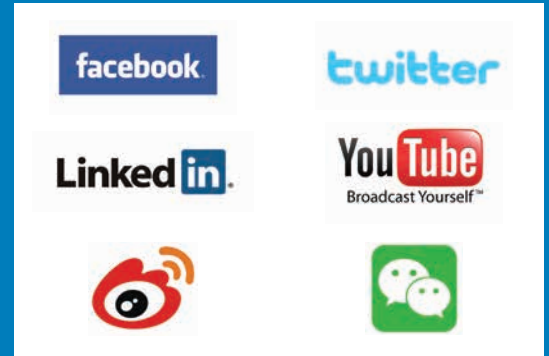

Stay Connected.

The latest happenings are being posted on LinkedIn, Twitter, Facebook, Weibo and WeChat! Sign up for one or all of the sites below and stay connected with Artesyn Embedded Power!

www.linkedin.com/company/artesyn
www.facebook.com/artesynembedded
www.twitter.com/artesynembedded
www.youtube.com/user/artesynembedded
www.weibo.com/artesynchina

ARTESYNTM
An Advanced Energy Company

www.artesyn.com

For more information: www.artesyn.com
For support: productsupport.ep@artesyn.com

Issue API 01.03.2020