

Raspberry Pi-4 Power-Hat Case Assembly with Axial Fan

multicomp PRO

Pi-4 Case Assembly

**RoHS
Compliant**



Contents Includes

- Black ABS case
- Power-HAT PCB Assembly with Fan Bracket
- 30mm 5V DC fan – MP001243

Diagram

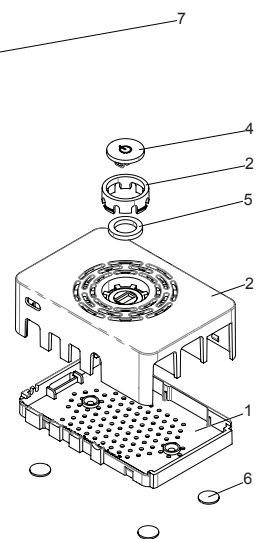
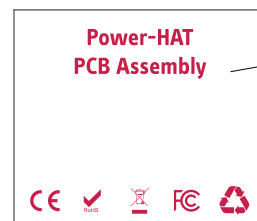
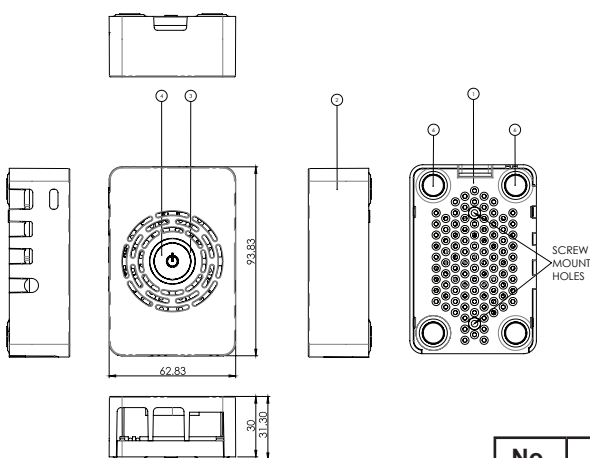

No.	Description	Qty.
1	Pi-4 Standard Base Moulding	1
2	Pi-4 Power Hat Upper Moulding	
3	Pi-4 LED Moulding	
4	Pi-4 Button Moulding	
5	Pi-4 Power Button Foam Pad	4
6	TECHNI-3 Foam Rubber Foot	
7	Power-Hat PCB Assembly INC Fan Bracket	1

Mechanical Dimensions

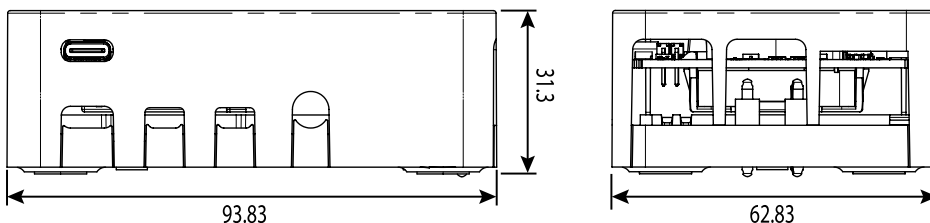

Dimensions : Millimetres

Newark.com/multicomp-pro
Farnell.com/multicomp-pro
Element14.com/multicomp-pro

multicomp PRO

Raspberry Pi-4 Power-Hat Case Assembly with Axial Fan

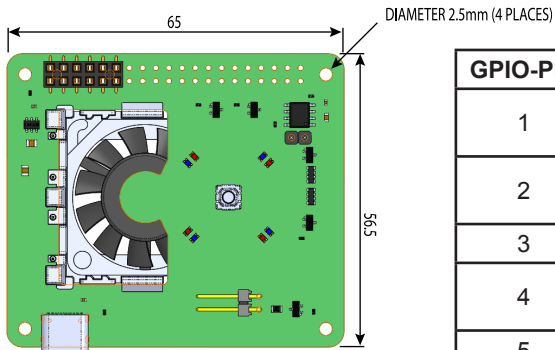

GPIO-PIN	BCM-Name	Signal	Description
1	3.3V	Power	Used by Power-HAT to enable Green LEDs
2	5.0V	Power	Switched 5V power from Power-HAT to Pi
3	I2C_SDA	Not Used	
4	5.0V	Power	Switched 5V power from Power-HAT to Pi
5	I2C_SCL	Not Used	
6	GND	GND	
7	GPIO4	Not Used	
8	GPIO14	Fan Control	Set GPIO14 HIGH to enable fan
9	GND	GND	
10	GPIO15	IR Input	Optional IR receiver (Not Fitted)
11	GPIO17	Shutdown_Req	Signal from Power-HAT to Pi to request a shut-down.
12	GPIO18	Shutdown_Done	Signal from Pi to indicate shutdown has completed. The Power-HAT removes the power from the Pi once this signal is asserted.

Mechanics

Board Thickness	1.6mm
Overall Size	65mm × 56.5mm
Max. Fan size	30mm × 30mm × 6.9mm

Dimensions : Millimetres

30mm 5V DC Axial Fan



Mechanical Characteristic

Motor Design	: Single phase, 4-poles Brushless DC motor
Bearing System	: Vapo bearing system
Materials of Frame	: Thermoplastic PBT of UL 94V-0
Materials of Fan Blade	: Thermoplastic PBT of UL 94V-0
Direction of Rotation	: Counter-clockwise viewed from front of fan blade
Mounting Holes	: Diameter 3.2mm in 3 holes
Weight	: 6g

Raspberry Pi-4 Power-Hat Case Assembly with Axial Fan



Electric Characteristic

Rated Voltage : 5V DC
 Rated Current : 112mA / Max. 124mA
 Rated Power Consumption : 0.56 Watts / Max. 0.62 Watts
 Safety Power Consumption : 0.72 Watts
 Operating Voltage Range : 2.5V DC to 6V DC
 Starting Voltage : 2.5V DC (25°C power On/Off)
 Operating Temperature Range : -10°C to +70°C
 Storage Temperature Range : -40°C to +70°C

Performance Characteristic

Rated Speed : 9100 RPM \pm 15% at rated voltage
 Air Flow : 4.9 CFM
 Static Pressure : 0.17 Inch - H₂O / Min. 0.14 Inch - H₂O
 Acoustic Noise : 23.6dB(A) / Max. 28.3dB(A)
 Insulation Class : UL Class A
 Insulation Resistance : 10M Ω at 500V DC between internal stator and Lead wire (+)
 Plastic Housing : Applied AC 500V for one minute or AC 600V for 2 Seconds between housing and lead wire (+)
 Life Expectancy : 60,000 Hours at 40°C, 65% humidity, 90% CL
 Protection : Automatic Restart
 Note: The motor will shut down when rotor was locked, then auto restart within 10 seconds
 Polarity Protection

Performance Curves

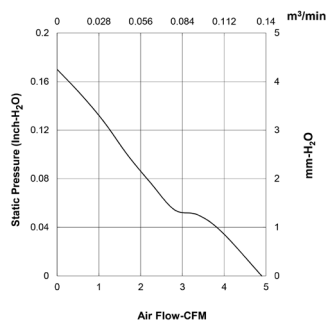

Diagram

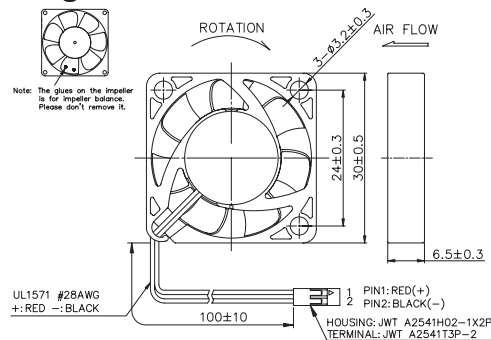

Dimensions : Millimetres

Part Number Table

Description	Part Number
Raspberry Pi-4 Power-HAT Case Assembly with Axial Fan	MP001926

Important Notice : This data sheet and its contents (the "Information") belong to the members of the AVNET group of companies (the "Group") or are licensed to it. No licence is granted for the use of it other than for information purposes in connection with the products to which it relates. No licence of any intellectual property rights is granted. The Information is subject to change without notice and replaces all data sheets previously supplied. The Information supplied is believed to be accurate but the Group assumes no responsibility for its accuracy or completeness, any error in or omission from it or for any use made of it. Users of this data sheet should check for themselves the Information and the suitability of the products for their purpose and not make any assumptions based on information included or omitted. Liability for loss or damage resulting from any reliance on the Information or use of it (including liability resulting from negligence or where the Group was aware of the possibility of such loss or damage arising) is excluded. This will not operate to limit or restrict the Group's liability for death or personal injury resulting from its negligence. Multicomp Pro is the registered trademark of Premier Farnell Limited 2019.

Newark.com/multicomp-pro
 Farnell.com/multicomp-pro
 Element14.com/multicomp-pro

