

---

---

**SAM E51 Curiosity Nano User Guide**

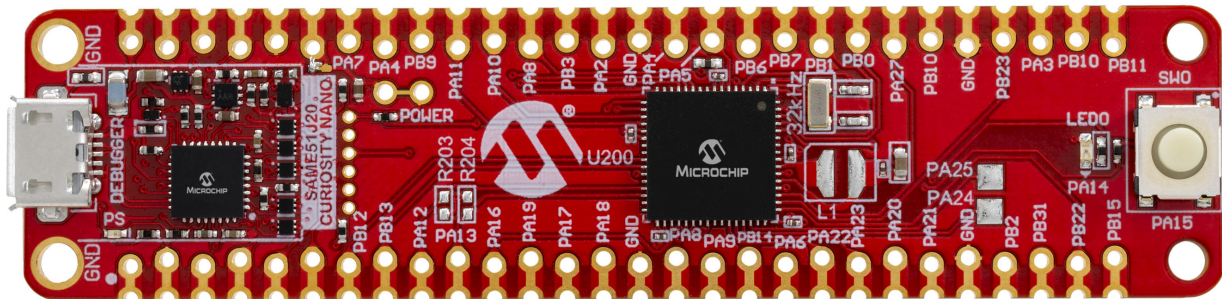
---

---

**Preface**

---

The SAME51J20A Curiosity Nano Evaluation Kit (EV76S68A) is a hardware platform used to evaluate the SAME51J20A microcontroller (MCU), and it is supported by the MPLAB® X Integrated Development Environment (IDE). The evaluation kit provides easy access to the features of the SAME51J20A to integrate the device into a custom design. The Curiosity Nano series of evaluation kits includes an On-Board Nano Debugger, therefore no external tools are necessary to program the SAME51J20A device. The SAME51J20A Curiosity Nano Evaluation Kit is shown in the following figure.



---

## Table of Contents

---

Preface.....	1
1. Introduction.....	3
1.1. Features.....	3
1.2. Kit Overview.....	3
2. Getting Started.....	4
2.1. Curiosity Nano Quick Start.....	4
3. Curiosity Nano.....	5
3.1. On-Board Debugger.....	5
3.2. Curiosity Nano Standard Pinout.....	6
3.3. Power Supply.....	7
3.4. Disconnecting the On-Board Debugger.....	8
3.5. Current Measurement.....	10
4. Hardware.....	11
4.1. Connectors.....	11
4.2. Peripherals.....	12
4.3. On-Board Debugger Implementation.....	13
5. Hardware Revision History.....	15
5.1. Identifying Product ID and Revision.....	15
6. Schematics.....	16
7. Revision History.....	19
The Microchip Website.....	20
Product Change Notification Service.....	20
Customer Support.....	20
Microchip Devices Code Protection Feature.....	20
Legal Notice.....	20
Trademarks.....	21
Quality Management System.....	21
Worldwide Sales and Service.....	22

## 1. Introduction

The SAME51J20A Curiosity Nano Evaluation Kit is a hardware platform used to evaluate the SAME51J20A microcontroller (MCU). Supported by the MPLAB® X Integrated Development Environment (IDE), the kit provides easy access to the features of the SAME51J20A, and explains how to integrate the device into a custom design. The Curiosity Nano series of evaluation kits include an on-board debugger. No external tools are necessary to program the SAME51J20A.

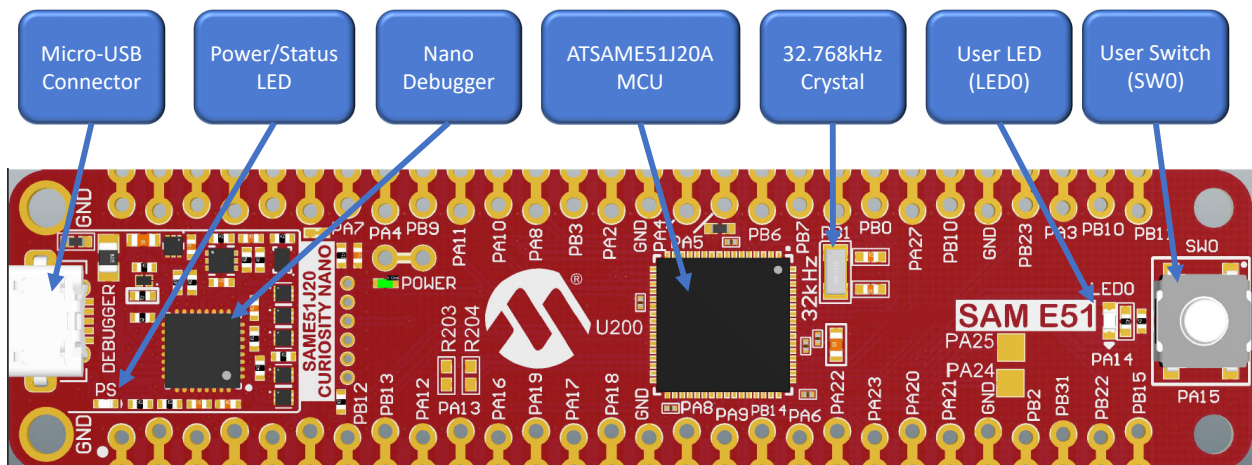
### 1.1 Features

- SAME51J20A microcontroller
- One user LED (yellow)
- One mechanical user switch
- On-board debugger
  - Board identification in MPLAB X IDE
  - One Green power/status LED
  - Programming and debugging
  - Virtual COM port (CDC)
  - One logic analyzer (DGI GPIO)
- USB powered
- Adjustable target voltage
  - MIC5353 LDO regulator controlled by the on-board debugger
  - 1.8-3.6v output voltage
  - 500 mA maximum output current (limited by ambient temperature and output voltage)

### 1.2 Kit Overview

The SAME51J20A Curiosity Nano evaluation kit is a hardware platform used to evaluate the SAME51J20A, as shown in the figure below.

Figure 1-1. SAME51J20A



## **2. Getting Started**

### **2.1 Curiosity Nano Quick Start**

Follow these steps to exploring the Curiosity Nano platform:

1. Download MPLAB X IDE.
2. Launch MPLAB X IDE.
3. Connect a USB cable (Standard-A to Micro-B or Micro-AB) between the PC and the debug USB port on the kit.

When the Curiosity Nano kit is connected to the user computer for the first time, the operating system will perform a driver software installation. The driver file supports both 32-bit and 64-bit versions of Microsoft® Windows® XP, Windows Vista®, Windows 7, Windows 8, and Windows 10. The drivers for the kit are included with MPLAB X IDE.

Once the Curiosity Nano board is powered, the green status LED will be lit and MPLAB X IDE will auto-detect which Curiosity Nano board is connected. MPLAB X IDE will present relevant information, such as data sheets and kit documentation. The SAME51J20A device is programmed and debugged by the on-board debugger, therefore no external programmer or debugger tool is required.

### 3. Curiosity Nano

The Curiosity Nano is an evaluation platform that provides a set of small boards with access to most of the microcontroller's I/O. The platform consists of a series of low pin-count microcontroller (MCU) boards, which are integrated with MPLAB X IDE to present relevant user guides, application notes, data sheets, and example code. The platform features a virtual COM port (CDC) for serial communication to a host PC, and a Data Gateway Interface (DGI) GPIO.

#### 3.1 On-Board Debugger

The SAME51J20A Curiosity Nano contains an on-board debugger for programming and debugging. The on-board debugger is a composite USB device of several interfaces: a debugger, a mass storage device, a data gateway, and a virtual COM port (CDC). Together with MPLAB X IDE, the on-board debugger interface can program and debug the SAME51J20A. A Data Gateway Interface (DGI) is available for use with logic analyzer channels for code instrumentation, and to visualize program flow. DGI GPIOs can be graphed using the Data Visualizer. The Virtual COM port is connected to a UART on the SAME51J20A and provides an easy way to communicate with the target application through terminal software. The on-board debugger controls one Power/Status LED (marked PS) on the SAME51J20A Curiosity Nano board. The following table shows how the LED is controlled in different operation modes.

**Table 3-1. On-Board Debugger LED Control**

Operation Mode	Status LED
Boot Loader mode	LED blink at 1 Hz during power up.
Power-up	LED is lit - constant.
Normal operation	LED is lit - constant.
Programming	Activity indicator; the LED flashes slowly during programming or debugging.
Fault	The LED flashes fast if a power fault is detected.
Sleep/Off	LED is Off. The on-board debugger is either in Sleep mode or powered down. This can occur if the kit is externally powered.

##### 3.1.1 Virtual COM Port

A general-purpose USB serial bridge between a host PC and a target device.

###### 3.1.1.1 Overview

The debugger implements a composite USB device that includes a standard Communications Device Class (CDC) interface, which appears on the host as a virtual COM Port. The CDC can be used to stream arbitrary data in both directions between the host and the target. Characters sent from the host will appear in UART form on the CDC TX pin, and UART characters sent into the CDC RX pin will be sent back to the host. On Windows machines, the CDC will enumerate as the Curiosity Virtual COM Port and appear in the Ports section of the device manager. The COM port number is usually shown here.



**Tip:** On older Windows systems a USB driver is required for the CDC. This driver is included in MPLAB X IDE installations. On Linux machines, the CDC will enumerate and appear as `/dev/ttyACM#`. On MAC machines, the CDC will enumerate and appear as `/dev/tty.usbmodem#`. Depending on which terminal program is used, it will appear in the available list of modems as `usbmodem#`.

###### 3.1.1.2 Limitations

Not all UART features are implemented in the debugger CDC. The constraints are outlined here:

- **Baud rate:** Must be in the range of 1200 bps to 500 kbps. Values outside this range will be capped to these values without warning. Baud rate can be changed on-the-fly.

- **Character format:** Only 8-bit characters are supported
- **Parity:** Can be odd, even, or none
- **Hardware flow control:** Not supported
- **Stop bits:** One or two bits are supported

### 3.1.1.3 Signaling

During USB enumeration, the host OS will start both communication and data pipes of the CDC interface. At this point, it is possible to set and read back the baud rate and other UART parameters of the CDC, but data sending and receiving will not be enabled. When a terminal connects on the host, it must assert the DTR signal. This is a virtual control signal that is implemented on the USB interface but not in the hardware on the debugger. Asserting a DTR from the host will indicate to the debugger that a CDC session is active, and it will enable its level shifters (if available), and start the CDC data send and receive mechanisms. Disserting the DTR signal will not disable the level shifters, but it will disable the receiver, hence no further data will be streamed to the host. Data packets that are already queued up for sending to the target will continue to be sent out, but no further data will be accepted.

### 3.1.1.4 Advanced Use

In CDC Override mode in normal operation, the on-board debugger is a true UART bridge between the host and the device. However, under certain use cases, the debugger can override the Basic Operating mode and use the CDC pins for other purposes. Dropping a text file (with extension .txt) into the debugger's mass storage drive can be used to send characters out of the CDC TX pin. The text file must start with the characters "`CMD: SEND_UART =`". The maximum message length is 50 characters, and all remaining data in the frame is ignored. The default baud rate used in this mode is 9600 bps, but if the CDC is already active or has been configured, the baud rate last used still applies.

#### USB-Level Framing Considerations

Sending data from the host to the CDC can be done byte-wise or in blocks, which will be divided into 64-byte USB frames. Each frame will be queued up for sending to the CDC TX pin. Sending a small amount of data per frame can be inefficient, particularly at low baud rates, since the debugger buffers per frame, not byte. A maximum of 4 x 64-byte frames can be active at any time, the debugger will throttle the incoming frames accordingly. Sending full 64-byte frames containing data is the most efficient.

When receiving data from the target, the debugger will queue up incoming bytes into 64-byte frames, which are sent to the USB queue for transmission to the host when they are full. Incomplete frames are also pushed to the USB queue at approximately 100 ms intervals, triggered by USB start-of-frame tokens. Up to 8 x 64-byte frames can be active at any time. If the host, or software running on it, fails to receive the data fast enough, an overrun will occur. When this happens the last-filled buffer frame will be recycled instead of being sent to the USB queue, and a full frame of data will be lost. To prevent this occurrence, the user must ensure that the CDC data pipe is being read continuously, or the incoming data rate must be reduced.

## 3.2 Curiosity Nano Standard Pinout

The twelve edge connections closest to the USB connector on the Curiosity Nano kits have a standardized pinout. The program/debug pins have different functions depending on the target programming interface as shown in the following table and figure.

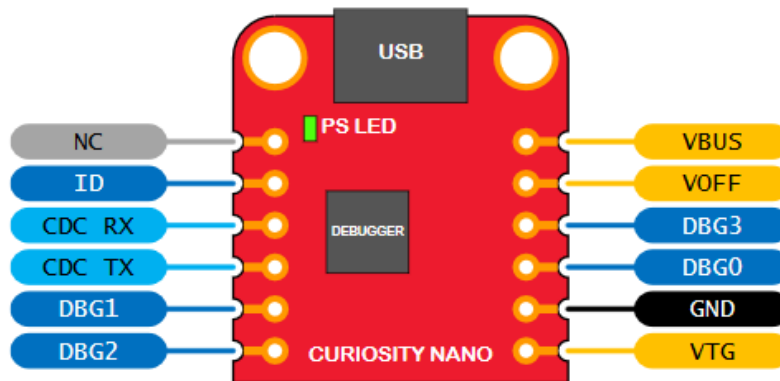
**Table 3-2. Curiosity Nano Standard Pinout**

Debugger Signal	ICSP Target	Description
NC	-	No connect.
ID	-	ID line for extensions.
CDC RX	UART TX	USB CDC RX line.
CDC TX	UART RX	USB CDC TX line.
DBG1	SWCLK	Debug clock line
DBG2	GPIO	DGI GPIO

.....continued

Debugger Signal	ICSP Target	Description
VTG	-	Target voltage
GND	-	Common ground.
DBG0	SWDATA	Debug data line.
DBG3	nRESET	Reset line
VOFF	-	Voltage Off input.
VBUS	-	VBUS voltage for external use.

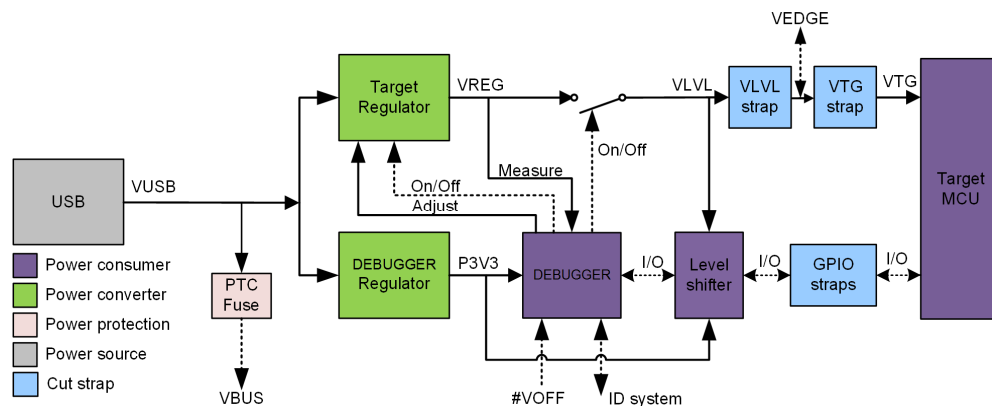
Figure 3-1. Curiosity Nano Standard Pinout



### 3.3 Power Supply

The kit is powered through the USB port and contains two regulators for generating 3.3V for the debugger, and an adjustable regulator for the target. The voltage from the USB connector can vary between 4.4V to 5.25V (according to the USB specification) and will limit the maximum voltage to the target. The following figure shows the entire power supply system on the SAME51J20A Curiosity Nano.

Figure 3-2. Power Supply Block Diagram

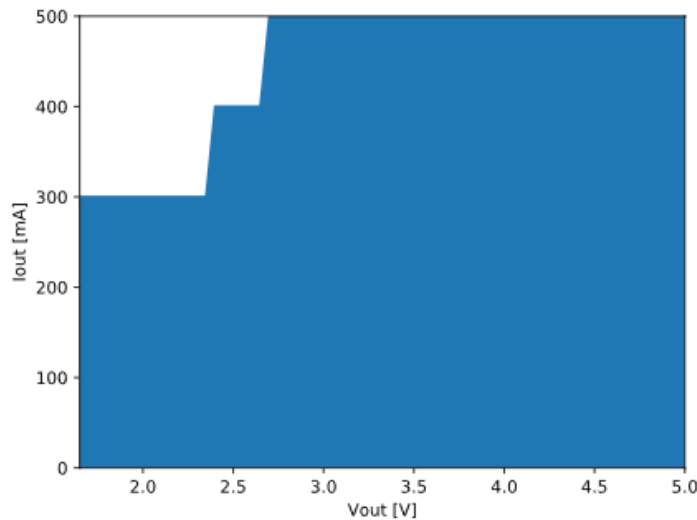


#### 3.3.1 Target Regulator

The target voltage regulator is a MIC5353 variable output LDO. The on-board debugger can adjust the voltage output that is supplied to the kit target section by manipulating the feedback voltage of the MIC5353. The hardware implementation is limited to an approximate voltage range from 1.8V to 5.1V. Additional output voltage limits are

configured in the debugger firmware to ensure that the output voltage never exceeds the hardware limits of the SAME51J20A microcontroller. The voltage limits configured in the on-board debugger on the SAME51J20A Curiosity Nano are 1.8V–3.6V. The target voltage is set to 3.3V in production and can be changed through MPLAB X IDE. Any change to the target voltage done in MPLAB X IDE is persistent, even through a power toggle. The MIC5353 supports a maximum current load of 500 mA. It is an LDO regulator in a small package, placed on a small PCB, and the thermal shutdown condition can be reached at lower loads than 500 mA. The maximum current load depends on the input voltage, set output voltage, and the ambient temperature. The following figure shows the safe operation area for the regulator, with an input voltage of 5.1V and an ambient temperature of 23°C.

**Figure 3-3. Target Regulator Safe Operation Area**



### 3.3.2 External Supply

The SAME51J20A Curiosity Nano can be powered by an external voltage instead of the on-board target regulator. When the Voltage Off (VOFF) pin is shorted to ground (GND) the on-board debugger firmware disables the target regulator and it is safe to apply an external voltage to the VTG pin.

**WARNING** Applying an external voltage to the VTG pin without shorting the VOFF to GND may cause permanent damage to the kit.

**WARNING** Absolute maximum external voltage is 5.5V for the level shifters on the board. Applying a higher voltage may cause permanent damage to the kit.

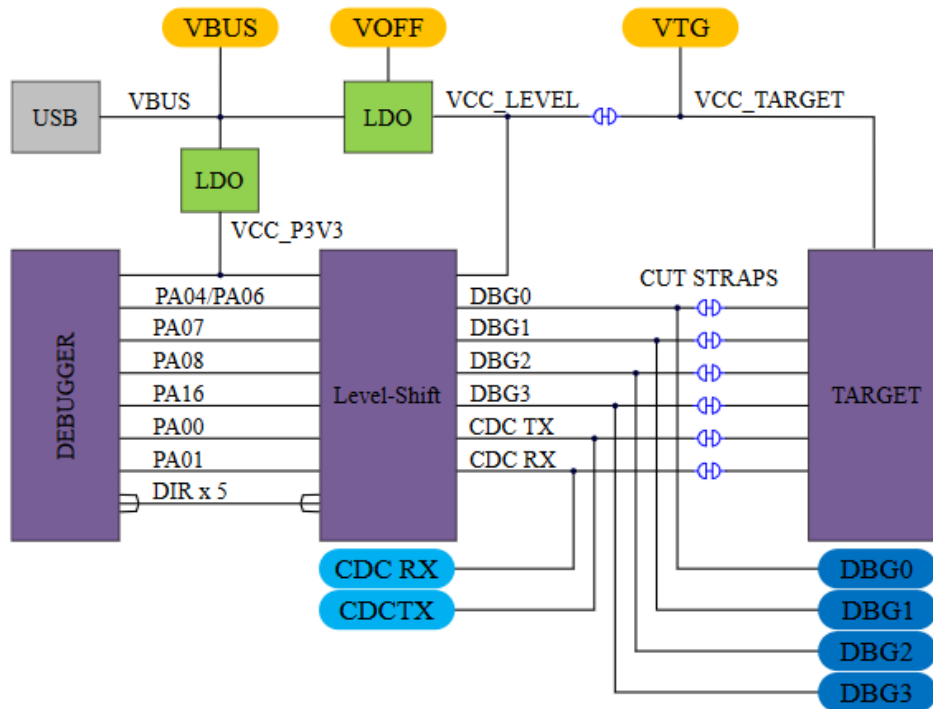
Programming, debugging, and data streaming is still possible while using external power: the debugger and signal level shifters will be powered from the USB cable. Both regulators, the debugger, and the level shifters are powered down when the USB cable is removed.

### 3.4 Disconnecting the On-Board Debugger

The following block diagram shows all the connections between the debugger and the SAME51J20A microcontroller. The rounded boxes represent connections to the board edge on the SAME51J20A Curiosity Nano. The signal names are shown in the following figure and printed in silkscreen on the bottom side of the board.

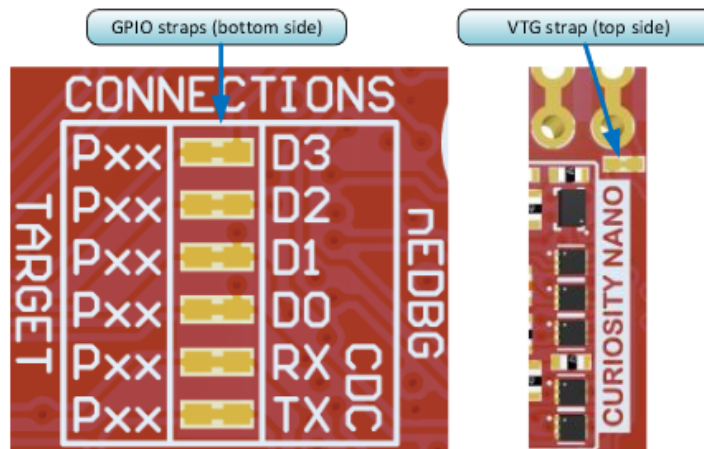


Figure 3-4. On-Board Debugger Connections



By cutting the GPIO straps with a sharp tool, as shown in the following figure, all I/O connected between the debugger and the SAME51J20A are completely disconnected. To completely disconnect the target regulator, cut the VTG strap shown in the following figure:

Figure 3-5. Location of GPIO Straps and VTG Strap



**Tip:**

1. Cutting the connections to the debugger will disable programming, debugging, data streaming, and the target power supply. The signals will also be disconnected from the board edge next to the on-board debugger section.
2. Solder in 0Ω resistors across the footprints or short-circuit them with tin solder to reconnect any cut signals.

### 3.5 Current Measurement

The power to the SAME51J20A is connected from the on-board power supply to the target voltage supply (VTG) with a cut strap as shown in [Disconnecting the On-Board Debugger](#). To measure the power consumption of the SAME51J20A and other peripherals connected to the board, cut the strap and connect an ammeter over the strap. The ammeter can be connected between the target VTG pad edge connector and an external power supply for easy measurement. Alternatively, an external power supply can be used as described in [External Supply](#).



**Important:** The on-board level shifters will draw a small amount of current even when they are not in use. A maximum of 10  $\mu\text{A}$  can be drawn from the VTG net and an additional 2  $\mu\text{A}$  can be drawn from each I/O pin connected to a level shifter for a total of 20  $\mu\text{A}$ . Disconnect the on-board debugger and level shifters as described in [Disconnecting the On-Board Debugger](#) to prevent any leakage.

---

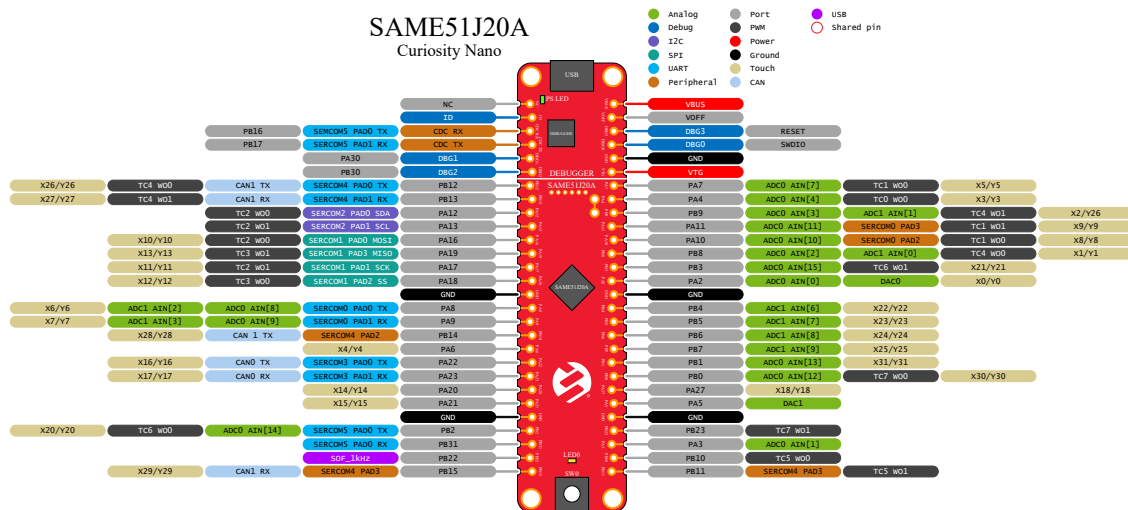
## 4. Hardware

### 4.1 Connectors

#### 4.1.1 SAME51J20A Curiosity Nano Pinout

All of the SAME51J20A I/O pins are accessible at the edge connectors on the SAME51J20A Curiosity Nano except the button and LED (PA15, PA14). The RA30 and RA31 pins are only available at the edge connector in the debugger section as long as the straps on the bottom are not cut.

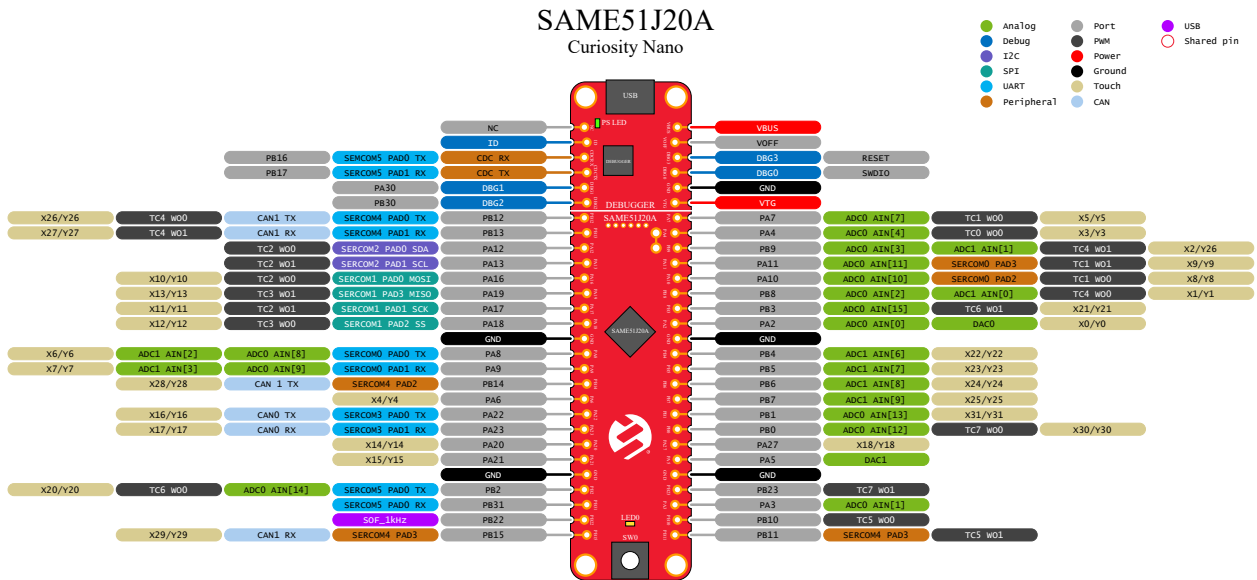
Figure 4-1. SAME51J20A Curiosity Nano Pinout



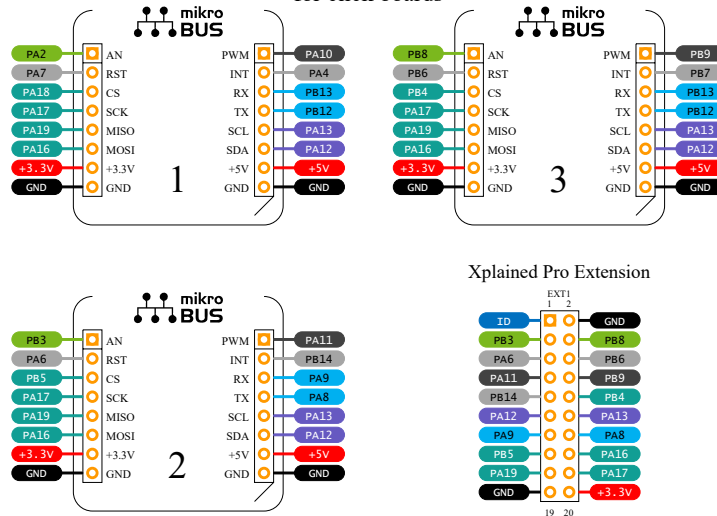
**Note:** Not all pin functions are listed in the diagram. Additional functions are available on these pins, for a list of additional functions please consult the latest data sheet available at [www.microchip.com](http://www.microchip.com).

#### 4.1.2 SAME51J20A Curiosity Nano Base Quick Reference

The SAME51J20A is compatible with the Curiosity Nano Base for click boards™ (AC164162). The following figure shows a simplified reference to enable quicker development. For additional information, visit [www.microchip.com/developmenttools/ProductDetails/AC164162](http://www.microchip.com/developmenttools/ProductDetails/AC164162).



### Curiosity Nano Base for click boards™



## 4.2 Peripherals

### 4.2.1 LED

One yellow user LED is available on the SAME51J20A Curiosity Nano kit that can be controlled with either GPIO or PWM. The LED can be activated by driving the connected I/O line to GND.

Table 4-1. LED Connection

SAME51J20A	Function	Shared Functionality
PA14	Yellow LED0	None

### 4.2.2 Mechanical Switch

The SAME51J20A Curiosity Nano has one mechanical switch. This is a generic user configurable switch. When the switch is pressed, it will drive the I/O line to ground (GND).



**Tip:** There is no pull-up resistor connected to the generic user switch. Remember to enable the internal pull-up in the SAME51J20A to use the switch.

**Table 4-2. Mechanical Switch**

SAME51J20A	Function	Shared Functionality
PA15	User Switch SW0	None

### 4.2.3 Crystal

The SAME51J20A Curiosity Nano board has a 32.768 kHz crystal.

By default, the crystal is populated and connected to the SAME51J20A and these pins are not usable as a GPIO. To use the crystal, no hardware modifications are required.

**Table 4-3. Crystal Connections**

SAME51J20A pin	Function	Shared Functionality
PA00	XIN32	None
PA01	XOUT32	None

## 4.3 On-Board Debugger Implementation

The SAME51J20A Curiosity Nano features an on-board debugger that can be used to program and debug the SAME51J20A using a Serial Wire Debug (SWD). The on-board debugger also includes a virtual COM port interface over UART and DGI GPIO. MPLAB X IDE can be used as a front-end for the on-board debugger for programming and debugging. A data visualizer can be used as a front-end for the CDC and DGI GPIO.

### 4.3.1 On-Board Debugger Connections

The following table shows the connections between the target and the debugger section. All connections between the target and the debugger are tri-stated as long as the debugger is not actively using the interface, therefore there is little contamination of the signals and the pins can be configured to the application requirements. For additional information on how to use the capabilities of the on-board debugger, see [Curiosity Nano](#).

**Table 4-4. On-Board Debugger Connections**

SAME51J20A pin	Debugger pin	Function	Shared Functionality
PB17	CDC TX	UART TX (SAME51J20A RX line)	Edge Connector
PB16	CDC RX	UART RX (SAME51J20A TX line)	Edge Connector
PA31	DBG0	SWDATA	Edge Connector
PA30	DBG1	SWCLK	Edge Connector
PB30	DBG2	SWO	Edge Connector
nRESET	DBG3	nRESET	Edge Connector
VCC_TARGET	VCC_LEVEL	1.8-3.6v supply voltage	Edge Connector
GND	GND	Common ground	Edge Connector

### 4.3.2 Extra Ports

This implementation has two pins that are not brought out to the edge connector, the access to these are provided as surface mount test points.

**Table 4-5. Extra Ports**

Pin	Port	Functions				
45	PA24	USB/DM	CAN0/TX	TC5/WO[0]	SERCOM3 & SERCOM5 -PAD[2]	CCL/IN[8]
46	PA25	USB/DP	CAN0/RX	TC5/WO[1]	SERCOM3 & SERCOM5 -PAD[3]	CCL/OUT[2]

## **5. Hardware Revision History**

This user guide provides the latest available revision of the kit. This chapter contains information about known issues, a revision history of older revisions, and how older revisions differ from the latest revision.

### **5.1 Identifying Product ID and Revision**

The revision and product identifier of Curiosity Nano boards can be found in two ways: either through the MPLAB X IDE or by looking at the sticker on the bottom side of the PCB. By connecting a Curiosity Nano board to a computer with MPLAB X IDE running, an information window will pop up. The first six digits of the serial number, which is listed under kit details, contains the product identifier and revision. The same information can be found on the sticker on the bottom side of the PCB. Most kits will print the identifier and revision in plain text as A09-nnn\rr, where nnn is the identifier and rr is the revision. Boards with limited space have a sticker with only a QR-code, which contains a serial number string. The serial number string has the following format:

“nnnnrrssssssss”

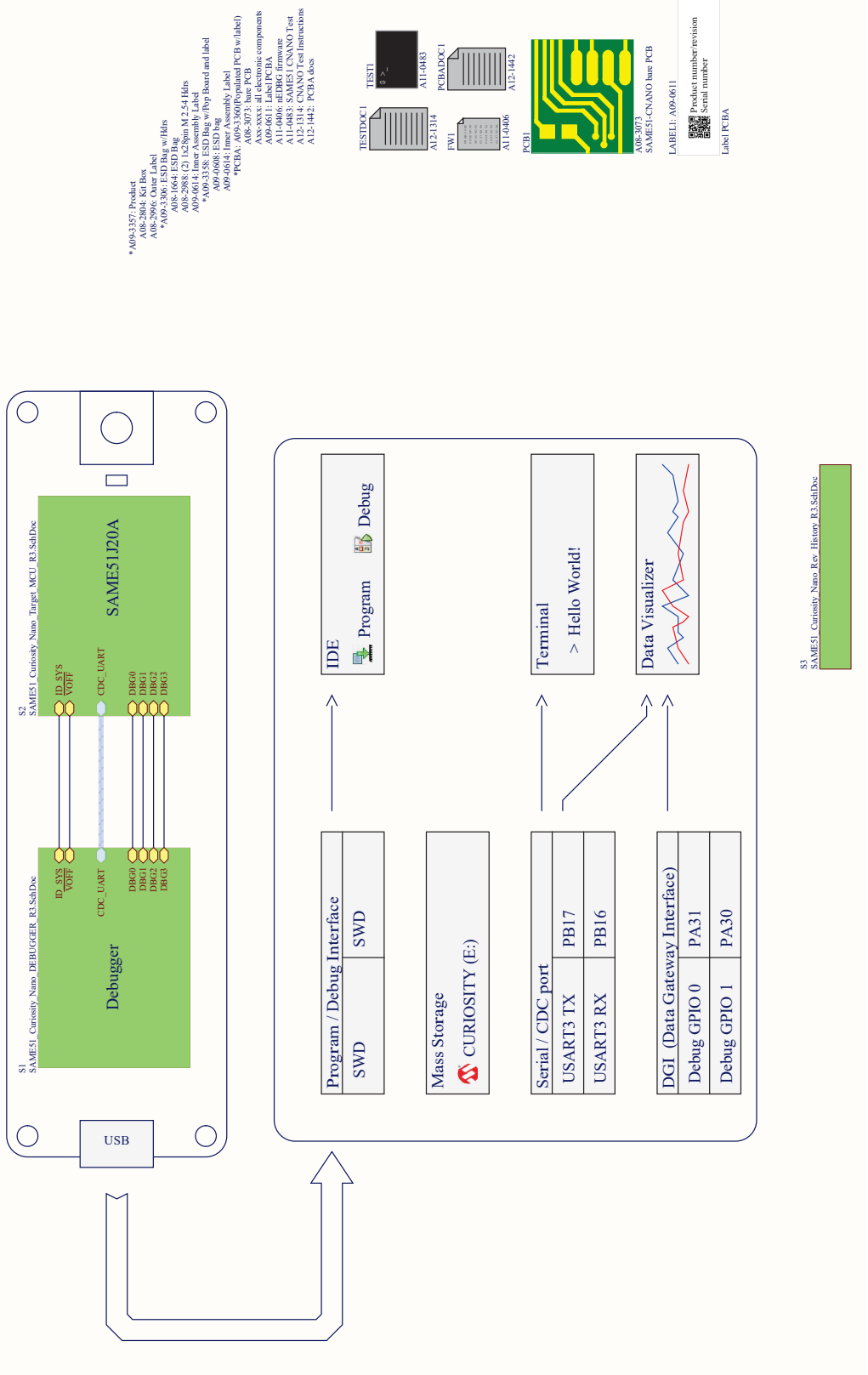
n = product identifier

r = revision

s = serial number

**6. Schematics**

# SAME51 Curiosity Nano



\*A09-3357: Product  
 A08-3073: PCB w/label  
 A08-2996: Outer Label  
 \*A09-3306: ESD Bag w/ Hdr's  
 A08-1664: ESD Bag  
 A09-3358: ESD Bag, M2 & 1 Hdr's  
 A09-0611: Assembly Label  
 A09-0611: Assembly Label  
 \*A09-3358: ESD Bag w/ Pop Board and label  
 A09-0608: ESD bag  
 A09-0608: ESD bag  
 A09-0608: ESD bag  
 A08-3073: bare PCB  
 A08-3073: bare PCB  
 Axx-xxxx: all electronic components  
 A09-0611: Label PCBA  
 A09-0611: Label PCBA  
 A11-0483: SAME51 CNANO Test  
 A12-1314: CNANO Test Instructions  
 A12-1442: PCBA.dcs







## **7. Revision History**

**Rev. A (08/2020)**

This is the initial released version of this document.

---

## The Microchip Website

---

Microchip provides online support via our website at [www.microchip.com/](http://www.microchip.com/). This website is used to make files and information easily available to customers. Some of the content available includes:

- **Product Support** – Data sheets and errata, application notes and sample programs, design resources, user's guides and hardware support documents, latest software releases and archived software
- **General Technical Support** – Frequently Asked Questions (FAQs), technical support requests, online discussion groups, Microchip design partner program member listing
- **Business of Microchip** – Product selector and ordering guides, latest Microchip press releases, listing of seminars and events, listings of Microchip sales offices, distributors and factory representatives

---

## Product Change Notification Service

---

Microchip's product change notification service helps keep customers current on Microchip products. Subscribers will receive email notification whenever there are changes, updates, revisions or errata related to a specified product family or development tool of interest.

To register, go to [www.microchip.com/pcn](http://www.microchip.com/pcn) and follow the registration instructions.

---

## Customer Support

---

Users of Microchip products can receive assistance through several channels:

- Distributor or Representative
- Local Sales Office
- Embedded Solutions Engineer (ESE)
- Technical Support

Customers should contact their distributor, representative or ESE for support. Local sales offices are also available to help customers. A listing of sales offices and locations is included in this document.

Technical support is available through the website at: [www.microchip.com/support](http://www.microchip.com/support)

---

## Microchip Devices Code Protection Feature

---

Note the following details of the code protection feature on Microchip devices:

- Microchip products meet the specification contained in their particular Microchip Data Sheet.
- Microchip believes that its family of products is one of the most secure families of its kind on the market today, when used in the intended manner and under normal conditions.
- There are dishonest and possibly illegal methods used to breach the code protection feature. All of these methods, to our knowledge, require using the Microchip products in a manner outside the operating specifications contained in Microchip's Data Sheets. Most likely, the person doing so is engaged in theft of intellectual property.
- Microchip is willing to work with the customer who is concerned about the integrity of their code.
- Neither Microchip nor any other semiconductor manufacturer can guarantee the security of their code. Code protection does not mean that we are guaranteeing the product as "unbreakable."

Code protection is constantly evolving. We at Microchip are committed to continuously improving the code protection features of our products. Attempts to break Microchip's code protection feature may be a violation of the Digital Millennium Copyright Act. If such acts allow unauthorized access to your software or other copyrighted work, you may have a right to sue for relief under that Act.

---

## Legal Notice

---

Information contained in this publication regarding device applications and the like is provided only for your convenience and may be superseded by updates. It is your responsibility to ensure that your application meets with

your specifications. MICROCHIP MAKES NO REPRESENTATIONS OR WARRANTIES OF ANY KIND WHETHER EXPRESS OR IMPLIED, WRITTEN OR ORAL, STATUTORY OR OTHERWISE, RELATED TO THE INFORMATION, INCLUDING BUT NOT LIMITED TO ITS CONDITION, QUALITY, PERFORMANCE, MERCHANTABILITY OR FITNESS FOR PURPOSE. Microchip disclaims all liability arising from this information and its use. Use of Microchip devices in life support and/or safety applications is entirely at the buyer's risk, and the buyer agrees to defend, indemnify and hold harmless Microchip from any and all damages, claims, suits, or expenses resulting from such use. No licenses are conveyed, implicitly or otherwise, under any Microchip intellectual property rights unless otherwise stated.

---

## **Trademarks**

---

The Microchip name and logo, the Microchip logo, Adaptec, AnyRate, AVR, AVR logo, AVR Freaks, BesTime, BitCloud, chipKIT, chipKIT logo, CryptoMemory, CryptoRF, dsPIC, FlashFlex, flexPWR, HELDO, IGLOO, JukeBlox, KeeLoq, Kleer, LANCheck, LinkMD, maXStylus, maXTouch, MediaLB, megaAVR, Microsemi, Microsemi logo, MOST, MOST logo, MPLAB, OptoLyzer, PackeTime, PIC, picoPower, PICSTART, PIC32 logo, PolarFire, Prochip Designer, QTouch, SAM-BA, SenGenuity, SpyNIC, SST, SST Logo, SuperFlash, Symmetricom, SyncServer, Tachyon, TempTrackr, TimeSource, tinyAVR, UNI/O, Vectron, and XMEGA are registered trademarks of Microchip Technology Incorporated in the U.S.A. and other countries.

APT, ClockWorks, The Embedded Control Solutions Company, EtherSynch, FlashTec, Hyper Speed Control, HyperLight Load, IntelliMOS, Libero, motorBench, mTouch, Powermite 3, Precision Edge, ProASIC, ProASIC Plus, ProASIC Plus logo, Quiet-Wire, SmartFusion, SyncWorld, Temux, TimeCesium, TimeHub, TimePictra, TimeProvider, Vite, WinPath, and ZL are registered trademarks of Microchip Technology Incorporated in the U.S.A.

Adjacent Key Suppression, AKS, Analog-for-the-Digital Age, Any Capacitor, AnyIn, AnyOut, BlueSky, BodyCom, CodeGuard, CryptoAuthentication, CryptoAutomotive, CryptoCompanion, CryptoController, dsPICDEM, dsPICDEM.net, Dynamic Average Matching, DAM, ECAN, EtherGREEN, In-Circuit Serial Programming, ICSP, INICnet, Inter-Chip Connectivity, JitterBlocker, KleerNet, KleerNet logo, memBrain, Mindi, MiWi, MPASM, MPF, MPLAB Certified logo, MPLIB, MPLINK, MultiTRAK, NetDetach, Omniscient Code Generation, PICDEM, PICDEM.net, PICkit, PICtail, PowerSmart, PureSilicon, QMatrix, REAL ICE, Ripple Blocker, SAM-ICE, Serial Quad I/O, SMART-I.S., SQI, SuperSwitcher, SuperSwitcher II, Total Endurance, TSHARC, USBCheck, VariSense, ViewSpan, WiperLock, Wireless DNA, and ZENA are trademarks of Microchip Technology Incorporated in the U.S.A. and other countries.

SQTP is a service mark of Microchip Technology Incorporated in the U.S.A.

The Adaptec logo, Frequency on Demand, Silicon Storage Technology, and Symmcom are registered trademarks of Microchip Technology Inc. in other countries.

GestIC is a registered trademark of Microchip Technology Germany II GmbH & Co. KG, a subsidiary of Microchip Technology Inc., in other countries.

All other trademarks mentioned herein are property of their respective companies.

© 2020, Microchip Technology Incorporated, Printed in the U.S.A., All Rights Reserved.

ISBN: 978-1-5224-6605-5

---

## **Quality Management System**

---

For information regarding Microchip's Quality Management Systems, please visit [www.microchip.com/quality](http://www.microchip.com/quality).

## Worldwide Sales and Service

AMERICAS	ASIA/PACIFIC	ASIA/PACIFIC	EUROPE
<p><b>Corporate Office</b> 2355 West Chandler Blvd. Chandler, AZ 85224-6199 Tel: 480-792-7200 Tel: 480-792-7277 Technical Support: <a href="http://www.microchip.com/support">www.microchip.com/support</a> Web Address: <a href="http://www.microchip.com">www.microchip.com</a></p> <p><b>Atlanta</b> Duluth, GA Tel: 678-957-9614 Fax: 678-957-1455</p> <p><b>Austin, TX</b> Tel: 512-257-3370</p> <p><b>Boston</b> Westborough, MA Tel: 774-760-0087 Fax: 774-760-0088</p> <p><b>Chicago</b> Itasca, IL Tel: 630-285-0071 Fax: 630-285-0075</p> <p><b>Dallas</b> Addison, TX Tel: 972-818-7423 Fax: 972-818-2924</p> <p><b>Detroit</b> Novi, MI Tel: 248-848-4000</p> <p><b>Houston, TX</b> Tel: 281-894-5983</p> <p><b>Indianapolis</b> Noblesville, IN Tel: 317-773-8323 Fax: 317-773-5453 Tel: 317-536-2380</p> <p><b>Los Angeles</b> Mission Viejo, CA Tel: 949-462-9523 Fax: 949-462-9608 Tel: 951-273-7800</p> <p><b>Raleigh, NC</b> Tel: 919-844-7510</p> <p><b>New York, NY</b> Tel: 631-435-6000</p> <p><b>San Jose, CA</b> Tel: 408-735-9110 Tel: 408-436-4270</p> <p><b>Canada - Toronto</b> Tel: 905-695-1980 Fax: 905-695-2078</p>	<p><b>Australia - Sydney</b> Tel: 61-2-9868-6733</p> <p><b>China - Beijing</b> Tel: 86-10-8569-7000</p> <p><b>China - Chengdu</b> Tel: 86-28-8665-5511</p> <p><b>China - Chongqing</b> Tel: 86-23-8980-9588</p> <p><b>China - Dongguan</b> Tel: 86-769-8702-9880</p> <p><b>China - Guangzhou</b> Tel: 86-20-8755-8029</p> <p><b>China - Hangzhou</b> Tel: 86-571-8792-8115</p> <p><b>China - Hong Kong SAR</b> Tel: 852-2943-5100</p> <p><b>China - Nanjing</b> Tel: 86-25-8473-2460</p> <p><b>China - Qingdao</b> Tel: 86-532-8502-7355</p> <p><b>China - Shanghai</b> Tel: 86-21-3326-8000</p> <p><b>China - Shenyang</b> Tel: 86-24-2334-2829</p> <p><b>China - Shenzhen</b> Tel: 86-755-8864-2200</p> <p><b>China - Suzhou</b> Tel: 86-186-6233-1526</p> <p><b>China - Wuhan</b> Tel: 86-27-5980-5300</p> <p><b>China - Xian</b> Tel: 86-29-8833-7252</p> <p><b>China - Xiamen</b> Tel: 86-592-2388138</p> <p><b>China - Zhuhai</b> Tel: 86-756-3210040</p>	<p><b>India - Bangalore</b> Tel: 91-80-3090-4444</p> <p><b>India - New Delhi</b> Tel: 91-11-4160-8631</p> <p><b>India - Pune</b> Tel: 91-20-4121-0141</p> <p><b>Japan - Osaka</b> Tel: 81-6-6152-7160</p> <p><b>Japan - Tokyo</b> Tel: 81-3-6880-3770</p> <p><b>Korea - Daegu</b> Tel: 82-53-744-4301</p> <p><b>Korea - Seoul</b> Tel: 82-2-554-7200</p> <p><b>Malaysia - Kuala Lumpur</b> Tel: 60-3-7651-7906</p> <p><b>Malaysia - Penang</b> Tel: 60-4-227-8870</p> <p><b>Philippines - Manila</b> Tel: 63-2-634-9065</p> <p><b>Singapore</b> Tel: 65-6334-8870</p> <p><b>Taiwan - Hsin Chu</b> Tel: 886-3-577-8366</p> <p><b>Taiwan - Kaohsiung</b> Tel: 886-7-213-7830</p> <p><b>Taiwan - Taipei</b> Tel: 886-2-2508-8600</p> <p><b>Thailand - Bangkok</b> Tel: 66-2-694-1351</p> <p><b>Vietnam - Ho Chi Minh</b> Tel: 84-28-5448-2100</p>	<p><b>Austria - Wels</b> Tel: 43-7242-2244-39 Fax: 43-7242-2244-393</p> <p><b>Denmark - Copenhagen</b> Tel: 45-4485-5910 Fax: 45-4485-2829</p> <p><b>Finland - Espoo</b> Tel: 358-9-4520-820</p> <p><b>France - Paris</b> Tel: 33-1-69-53-63-20 Fax: 33-1-69-30-90-79</p> <p><b>Germany - Garching</b> Tel: 49-8931-9700</p> <p><b>Germany - Haan</b> Tel: 49-2129-3766400</p> <p><b>Germany - Heilbronn</b> Tel: 49-7131-72400</p> <p><b>Germany - Karlsruhe</b> Tel: 49-721-625370</p> <p><b>Germany - Munich</b> Tel: 49-89-627-144-0 Fax: 49-89-627-144-44</p> <p><b>Germany - Rosenheim</b> Tel: 49-8031-354-560</p> <p><b>Israel - Ra'anana</b> Tel: 972-9-744-7705</p> <p><b>Italy - Milan</b> Tel: 39-0331-742611 Fax: 39-0331-466781</p> <p><b>Italy - Padova</b> Tel: 39-049-7625286</p> <p><b>Netherlands - Drunen</b> Tel: 31-416-690399 Fax: 31-416-690340</p> <p><b>Norway - Trondheim</b> Tel: 47-72884388</p> <p><b>Poland - Warsaw</b> Tel: 48-22-3325737</p> <p><b>Romania - Bucharest</b> Tel: 40-21-407-87-50</p> <p><b>Spain - Madrid</b> Tel: 34-91-708-08-90 Fax: 34-91-708-08-91</p> <p><b>Sweden - Gothenberg</b> Tel: 46-31-704-60-40</p> <p><b>Sweden - Stockholm</b> Tel: 46-8-5090-4654</p> <p><b>UK - Wokingham</b> Tel: 44-118-921-5800 Fax: 44-118-921-5820</p>