

(<https://www.dfrobot.com/product-1122.html>)

Introduction

It's time to get Bluetooth 4.0 into your project, together with your phone! For aficionados of smart devices and wearables, now you can go further than hacking things bought in the market to building your own prototype out of garage. The Bluno board (<https://www.dfrobot.com/category-250.html>) is first of its kind in intergrating BT 4.0(BLE) module into Arduino Uno (<https://www.dfrobot.com/product-610.html>), making it an ideal prototyping platform for both software and hardware developers to go wireless. You will be able to develop your own smart bracelet , smart pedometer and more. Through the low- power Bluetooth 4.0 (<https://www.dfrobot.com/category-79.html>) technology, real-time low energy communication can be made really easy.

Bluno integrates with a TI CC2540 BT 4.0 chip with the Arduino UNO development board. It allows wireless programming via BLE, supports Bluetooth HID, supports AT command to config the BLE, and you can upgrade BLE firmware easily. Bluno is also compatible with all Arduino Uno pins which means any project made with Uno can directly go wireless!

What's more, we also developed the App for the Bluno (both Android and IOS), and they are completely opensource, so that you can modify and develop your own BLE-hardware platform. Below is a quick demo video covering some of the major features of Bluno with the help of an Accessory Shield for Bluno, which will also be available very soon.

In short, you can use Bluno with any Bluetooth 4.0 compatible devices and enjoy features such as wireless transmission, master and slave settings, wireless burning, and even establishing a Bluetooth HID connection with the PC between devices.

! Note: Version difference, **Nano, 328** but not Uno. It is for the two batches of 2015.09.21 or 2015.10.08 which you can notice the date on the lable of the Nano's package, if you bought one or more in those, please choose the **Board** in the menu bar of Arduino IDE as **Nano, 328** instead of Uno.

Specification

- On-board BLE chip: TI CC2540
- Transmission range: more than 20m
- Wireless Programming Via BLE
- Support Bluetooth HID
- Support iBeacons
- Support AT command to config the BLE
- Transparent communication through Serial
- Easy to use BLE firmware updating
- DC Supply:USB Powered
- Microcontroller: Atmega328
- Bootloader: Arduino Uno
- Compatible with the Arduino Uno pin mapping
- Size: 53mmx19mmx12mm
- Weight: 20g
- Support Device List
(https://www.dfrobot.com/wiki/index.php/Bluno_SKU:DFR0267#Device_Support)

PinOut

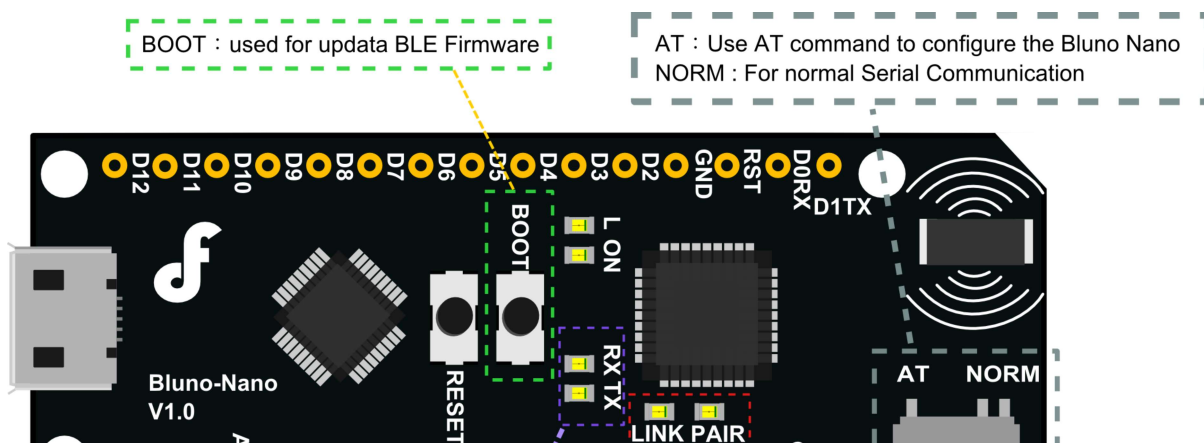

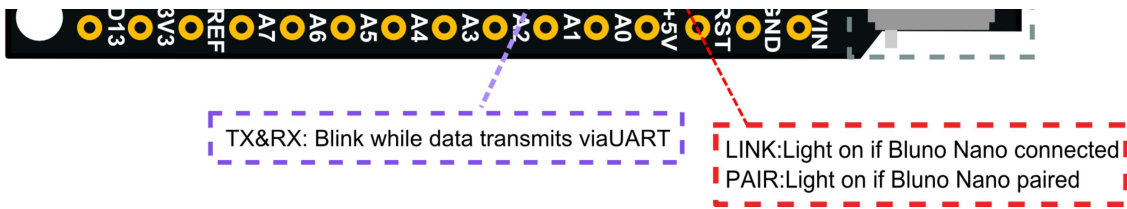

Basic Demo with Bluno nano

In this section, you can use the BLUNO nano to connect with the Android phone or iPhone .

Tools required

- Bluno nano x1
- Android 4.3 + Devices with BLE or IOS 7.0 + Devices
- Micro USB cable x1

Step by Step

The Step by Step tutorial of the Bluno nano is almost the same with the Bluno.

Step by Step Basic Demo tutorial.

(https://www.dfrobot.com/wiki/index.php/Bluno_SKU:DFR0267#Bluno_Basic_Demo)

Wireless Programming via BLE

In this section, we will learn how to Upload the sketch on air via BLE. It is really amazing that you can even use your mobile phone to do uploading process.

Tools required

- Bluno nano (<https://www.dfrobot.com/product-1122.html>) x2
- Micro USB cable x1
- XBee expansion shield x1

Step by Step

The Step by Step tutorial of the Bluno nano is almost the same with the Bluno.

How to Wireless Programming through BLE.

(https://www.dfrobot.com/wiki/index.php/Bluno_SKU:DFR0267#Wireless_Programming_via_BLE)

Forum page about BLE LINK Wireless Programming

(<https://www.dfrobot.com/forum/index.php?topic=17274.msg21490#msg21490>)

Update BLE Firmware

It is better to update the newest firmware for the better experience

It is better to update the newest firmware for the better experience.

As BLE Link is using CC2540 chip, the method of the updating is same as BLUNO

How to update the BLE firmware

(https://www.dfrobot.com/wiki/index.php/Bluno_SKU:DFR0267#Update_BLE_Firmware_on_Bluno.EF.BC.88AT.2BVERSION_to_check_the_version.EF.BC.89).

Configure the BLE through AT command

There are three revolutionary BLE firmware versions now, maybe it will be more.

For the reason of unified management, we will put all BLE AT command on the BLUNO wiki page

BLE AT Command Configuration

(https://www.dfrobot.com/wiki/index.php/Bluno_SKU:DFR0267#Configure_the_BLE_through_AT_command)

More

- BLE-link Documents shared with Bluno

(https://www.dfrobot.com/wiki/index.php/Bluno_SKU:DFR0267#Documents)



Get it from **Bluno Nano - An Arduino Nano with Bluetooth 4.0**

(<https://www.dfrobot.com/product-1122.html>) or **DFRobot Distributor**.

(<https://www.dfrobot.com/index.php?route=information/distributorslogo>)

Category: DFRobot (<https://www.dfrobot.com/>) > Arduino (<https://www.dfrobot.com/category-35.html>) > Arduino Microcontroller (<https://www.dfrobot.com/category-104.html>) category: Product Manual (category__Product_Manual) category: MicroControllers (category__MicroControllers) category: Wireless (category__Wireless)