



Product Change Notification / SYST-09XAWH858

Date:

12-Oct-2020

Product Category:

16-Bit - Microcontrollers and Digital Signal Controllers, 32-bit Microcontrollers

PCN Type:

Document Change

Notification Subject:

ERRATA - dsPIC33EPXXXGP50X, dsPIC33EPXXXMC20X/50X AND PIC24EPXXXGP/MC20X Errata Document Revision

Affected CPNs:

[SYST-09XAWH858_Affected_CPN_10122020.pdf](#)

[SYST-09XAWH858_Affected_CPN_10122020.csv](#)

Notification Text:

SYST-09XAWH858

Microchip has released a new Product Documents for the dsPIC33EPXXXGP50X, dsPIC33EPXXXMC20X/50X AND PIC24EPXXXGP/MC20X Errata of devices. If you are using one of these devices please read the document located at [dsPIC33EPXXXGP50X, dsPIC33EPXXXMC20X/ 50X AND PIC24EPXXXGP/ MC20X Errata](#).

Notification Status: Final

Description of Change: Added data sheet clarifications 1 (Pin Diagrams), 2 (Electrical Characteristics), 3 (Packaging Information) and 4 (Product Identification System).

Impacts to Data Sheet: None

Reason for Change: To Improve Productivity

Change Implementation Status: Complete

Date Document Changes Effective: 12 Oct 2020

NOTE: Please be advised that this is a change to the document only the product has not been changed.

Markings to Distinguish Revised from Unrevised Devices: N/A

Attachments:

[dsPIC33EPXXXGP50X, dsPIC33EPXXXMC20X/ 50X AND PIC24EPXXXGP/ MC20X Errata](#)

Please contact your local [Microchip sales office](#) with questions or concerns regarding this notification.

Terms and Conditions:

If you wish to receive Microchip PCNs via email please register for our PCN email service at our [PCN home page](#) select register then fill in the required fields. You will find instructions about registering for Microchips PCN email service in the [PCN FAQ](#) section.

If you wish to change your PCN profile, including opt out, please go to the [PCN home page](#) select login and sign into your myMicrochip account. Select a profile option from the left navigation bar and make the applicable selections.

Affected Catalog Part Numbers (CPN)

DSPIC33EP512GP502-E/MM
DSPIC33EP512MC202-E/MM
DSPIC33EP512MC502-E/MM
DSPIC33EP512GP502-E/SP
DSPIC33EP512MC202-E/SP
DSPIC33EP512MC502-E/SP
DSPIC33EP512MC502-E/SO
DSPIC33EP512GP506-E/MR
DSPIC33EP512MC206-E/MR
DSPIC33EP512MC506-E/MR
DSPIC33EP512GP504-E/MV
DSPIC33EP512MC204-E/MV
DSPIC33EP512MC504-E/MV
DSPIC33EP512GP504-E/ML
DSPIC33EP512MC204-E/ML
DSPIC33EP512MC504-E/ML
DSPIC33EP512GP504-E/PT
DSPIC33EP512MC504-E/PT
DSPIC33EP512GP506-E/PT
DSPIC33EP512MC206-E/PT
DSPIC33EP512MC506-E/PT
DSPIC33EP512GP506-E/PTVAO
DSPIC33EP512GP502-I/MM
DSPIC33EP512MC202-I/MM
DSPIC33EP512MC502-I/MM
DSPIC33EP512GP502-I/SP
DSPIC33EP512MC202-I/SP
DSPIC33EP512MC502-I/SP
DSPIC33EP512GP502-I/SO
DSPIC33EP512MC202-I/SO
DSPIC33EP512MC502-I/SO
DSPIC33EP512GP506-I/MR
DSPIC33EP512MC206-I/MR
DSPIC33EP512MC506-I/MR
DSPIC33EP512GP504-I/MV
DSPIC33EP512MC204-I/MV
DSPIC33EP512MC504-I/MV
DSPIC33EP512GP504-I/ML
DSPIC33EP512MC204-I/ML
DSPIC33EP512MC504-I/ML
DSPIC33EP512GP504-I/PT
DSPIC33EP512MC204-I/PT
DSPIC33EP512MC504-I/PT
DSPIC33EP512GP506-I/PT
DSPIC33EP512MC206-I/PT
DSPIC33EP512MC506-I/PT

DSPIC33EP512GP504T-H/TL
DSPIC33EP512MC204T-H/TL
DSPIC33EP512MC504T-H/TL
DSPIC33EP512GP502T-H/MM
DSPIC33EP512MC202T-H/MM
DSPIC33EP512MC502T-H/MM
DSPIC33EP512GP506T-H/MR
DSPIC33EP512MC206T-H/MR
DSPIC33EP512MC506T-H/MR
DSPIC33EP512GP504T-H/MV
DSPIC33EP512MC204T-H/MV
DSPIC33EP512MC504T-H/MV
DSPIC33EP512GP504T-H/ML
DSPIC33EP512MC204T-H/ML
DSPIC33EP512MC504T-H/ML
DSPIC33EP512GP504T-H/PT
DSPIC33EP512MC204T-H/PT
DSPIC33EP512MC504T-H/PT
DSPIC33EP512GP506T-H/PT
DSPIC33EP512MC206T-H/PT
DSPIC33EP512MC506T-H/PT
DSPIC33EP512GP504-H/TL
DSPIC33EP512MC204-H/TL
DSPIC33EP512MC504-H/TL
DSPIC33EP512GP502-H/MM
DSPIC33EP512MC202-H/MM
DSPIC33EP512MC502-H/MM
DSPIC33EP512GP502-H/SP
DSPIC33EP512MC502-H/SP
DSPIC33EP512GP506-H/MR
DSPIC33EP512MC206-H/MR
DSPIC33EP512MC506-H/MR
DSPIC33EP512GP504-H/MV
DSPIC33EP512MC204-H/MV
DSPIC33EP512MC504-H/MV
DSPIC33EP512GP504-H/ML
DSPIC33EP512MC204-H/ML
DSPIC33EP512MC504-H/ML
DSPIC33EP512GP504-H/PT
DSPIC33EP512MC204-H/PT
DSPIC33EP512MC504-H/PT
DSPIC33EP512GP506-H/PT
DSPIC33EP512MC206-H/PT
DSPIC33EP512MC506-H/PT
DSPIC33EP512GP502T-I/MM
DSPIC33EP512GP502T-I/SO
DSPIC33EP512GP506T-I/MR
DSPIC33EP512MC206T-I/MR
DSPIC33EP512MC506T-I/MR

DSPIC33EP512GP504T-I/MV
DSPIC33EP512MC204T-I/MV
DSPIC33EP512MC504T-I/MV
DSPIC33EP512GP504T-I/ML
DSPIC33EP512MC204T-I/ML
DSPIC33EP512MC504T-I/ML
DSPIC33EP512GP506T-I/PT
DSPIC33EP512GP502T-E/MM
DSPIC33EP512MC502T-E/MM
DSPIC33EP512GP506T-E/MR
DSPIC33EP512MC206T-E/MR
DSPIC33EP512MC506T-E/MR
DSPIC33EP512GP504T-E/MV
DSPIC33EP512MC204T-E/MV
DSPIC33EP512MC504T-E/MV
DSPIC33EP512MC204T-E/ML
DSPIC33EP512MC504T-E/ML
DSPIC33EP512GP506T-E/PTVAO
DSPIC33EP64MC202-E/4NV07
DSPIC33EP64MC204-E/TL
DSPIC33EP64MC504-E/TL
DSPIC33EP64MC203-E/TL
DSPIC33EP64MC503-E/TL
DSPIC33EP64GP502-E/MM
DSPIC33EP64MC202-E/MM
DSPIC33EP64MC502-E/MM
DSPIC33EP64MC202-E/MMV05
DSPIC33EP64GP502-E/SP
DSPIC33EP64MC202-E/SP
DSPIC33EP64MC502-E/SP
DSPIC33EP64GP502-E/SS
DSPIC33EP64MC202-E/SS
DSPIC33EP64MC502-E/SS
DSPIC33EP64MC202-E/SSVAO
DSPIC33EP64GP502-E/SSVAO
DSPIC33EP64GP502-E/SO
DSPIC33EP64MC202-E/SO
DSPIC33EP64MC502-E/SO
DSPIC33EP64GP506-E/MR
DSPIC33EP64MC206-E/MR
DSPIC33EP64MC506-E/MR
DSPIC33EP64GP504-E/MV
DSPIC33EP64MC204-E/MV
DSPIC33EP64MC504-E/MV
DSPIC33EP64GP503-E/M5
DSPIC33EP64MC503-E/M5
DSPIC33EP64MC203-E/M5
DSPIC33EP64GP504-E/ML
DSPIC33EP64MC204-E/ML

DSPIC33EP64MC504-E/ML
DSPIC33EP64GP504-E/PT
DSPIC33EP64MC204-E/PT
DSPIC33EP64MC504-E/PT
DSPIC33EP64MC204-E/PTV02
DSPIC33EP64MC504-E/PTVAO
DSPIC33EP64MC204-E/PTVAO
DSPIC33EP64GP506-E/PT
DSPIC33EP64MC206-E/PT
DSPIC33EP64MC506-E/PT
DSPIC33EP64MC206-E/PTA8
DSPIC33EP64MC506-E/PTVAO
DSPIC33EP64GP504-I/TL
DSPIC33EP64MC204-I/TL
DSPIC33EP64MC504-I/TL
DSPIC33EP64GP503-I/TL
DSPIC33EP64MC203-I/TL
DSPIC33EP64MC503-I/TL
DSPIC33EP64GP502-I/MM
DSPIC33EP64MC202-I/MM
DSPIC33EP64MC502-I/MM
DSPIC33EP64GP502-I/SP
DSPIC33EP64MC202-I/SP
DSPIC33EP64MC502-I/SP
DSPIC33EP64GP502-I/SS
DSPIC33EP64MC202-I/SS
DSPIC33EP64MC502-I/SS
DSPIC33EP64GP502-I/SO
DSPIC33EP64MC202-I/SO
DSPIC33EP64MC502-I/SO
DSPIC33EP64GP506-I/MRA3
DSPIC33EP64GP506-I/MR
DSPIC33EP64MC206-I/MR
DSPIC33EP64MC506-I/MR
DSPIC33EP64GP504-I/MV
DSPIC33EP64MC204-I/MV
DSPIC33EP64MC504-I/MV
DSPIC33EP64GP503-I/M5
DSPIC33EP64MC503-I/M5
DSPIC33EP64MC203-I/M5
DSPIC33EP64GP504-I/MLA3
DSPIC33EP64GP504-I/ML
DSPIC33EP64MC204-I/ML
DSPIC33EP64MC504-I/ML
DSPIC33EP64MC204-I/PTC02
DSPIC33EP64GP504-I/PT
DSPIC33EP64MC204-I/PT
DSPIC33EP64MC504-I/PT
DSPIC33EP64GP504-I/PTVAO

DSPIC33EP64MC206-I/PTA3
DSPIC33EP64GP506-I/PT
DSPIC33EP64MC206-I/PT
DSPIC33EP64MC506-I/PT
DSPIC33EP64MC206-I/PTV06
DSPIC33EP64GP506-I/PTVAO
DSPIC33EP64GP502T-H/MM
DSPIC33EP64MC202T-H/MM
DSPIC33EP64MC502T-H/MM
DSPIC33EP64MC202T-H/MMVAO
DSPIC33EP64MC202T-H/SSV11
DSPIC33EP64MC202T-H/SSVAO
DSPIC33EP64GP506T-H/MR
DSPIC33EP64MC206T-H/MR
DSPIC33EP64MC506T-H/MR
DSPIC33EP64GP504T-H/MV
DSPIC33EP64MC204T-H/MV
DSPIC33EP64MC504T-H/MV
DSPIC33EP64GP504T-H/ML
DSPIC33EP64MC204T-H/ML
DSPIC33EP64MC504T-H/ML
DSPIC33EP64MC204T-H/MLVAO
DSPIC33EP64MC204T-H/PT
DSPIC33EP64MC204T-H/PTV01
DSPIC33EP64MC504T-H/PTV03
DSPIC33EP64MC204T-H/PTV09
DSPIC33EP64MC204T-H/PTVAO
DSPIC33EP64MC206T-H/PT
DSPIC33EP64MC506T-H/PTVAO
DSPIC33EP64GP502-H/MM
DSPIC33EP64MC202-H/MM
DSPIC33EP64MC502-H/MM
DSPIC33EP64MC202-H/MMVAO
DSPIC33EP64MC502-H/SP
DSPIC33EP64MC202-H/SSV11
DSPIC33EP64GP506-H/MR
DSPIC33EP64MC206-H/MR
DSPIC33EP64MC506-H/MR
DSPIC33EP64GP504-H/MV
DSPIC33EP64MC204-H/MV
DSPIC33EP64MC504-H/MV
DSPIC33EP64GP503-H/M5
DSPIC33EP64MC503-H/M5
DSPIC33EP64MC203-H/M5
DSPIC33EP64GP504-H/ML
DSPIC33EP64MC204-H/ML
DSPIC33EP64MC504-H/ML
DSPIC33EP64MC204-H/MLVAO
DSPIC33EP64MC204-H/PT

DSPIC33EP64MC504-H/PT
DSPIC33EP64MC204-H/PTV01
DSPIC33EP64MC204-H/PTV09
DSPIC33EP64MC206-H/PT
DSPIC33EP64MC204T-I/TL
DSPIC33EP64MC504T-I/TL
DSPIC33EP64MC203T-I/TL
DSPIC33EP64MC503T-I/TL
DSPIC33EP64MC202T-I/MM
DSPIC33EP64MC502T-I/MM
DSPIC33EP64GP502T-I/SS
DSPIC33EP64MC202T-I/SS
DSPIC33EP64MC502T-I/SS
DSPIC33EP64GP502T-I/SO
DSPIC33EP64MC202T-I/SO
DSPIC33EP64MC502T-I/SO
DSPIC33EP64GP506T-I/MR
DSPIC33EP64MC206T-I/MR
DSPIC33EP64MC506T-I/MR
DSPIC33EP64GP504T-I/MV
DSPIC33EP64MC204T-I/MV
DSPIC33EP64MC504T-I/MV
DSPIC33EP64GP504T-I/ML
DSPIC33EP64MC204T-I/ML
DSPIC33EP64MC504T-I/ML
DSPIC33EP64MC204T-I/PTC01
DSPIC33EP64MC204T-I/PT
DSPIC33EP64MC504T-I/PT
DSPIC33EP64GP504T-I/PTVAO
DSPIC33EP64MC206T-I/PT
DSPIC33EP64MC506T-I/PT
DSPIC33EP64MC206T-I/PTV06
DSPIC33EP64MC202T-E/4NV07
DSPIC33EP64MC204T-E/TL
DSPIC33EP64MC504T-E/TL
DSPIC33EP64GP502T-E/MM
DSPIC33EP64MC202T-E/MM
DSPIC33EP64MC502T-E/MM
DSPIC33EP64MC202T-E/MMV05
DSPIC33EP64MC502T-E/MMV10
DSPIC33EP64MC202T-E/SSC05
DSPIC33EP64MC202T-E/SS
DSPIC33EP64MC502T-E/SS
DSPIC33EP64GP502T-E/SSVAO
DSPIC33EP64MC202T-E/SO
DSPIC33EP64MC502T-E/SO
DSPIC33EP64MC206T-E/MRC04
DSPIC33EP64GP506T-E/MR
DSPIC33EP64MC206T-E/MR

DSPIC33EP64MC506T-E/MR
DSPIC33EP64GP504T-E/MV
DSPIC33EP64MC204T-E/MV
DSPIC33EP64MC504T-E/MV
DSPIC33EP64GP504T-E/ML
DSPIC33EP64MC204T-E/ML
DSPIC33EP64MC504T-E/ML
DSPIC33EP64MC204T-E/MLVAO
DSPIC33EP64MC204T-E/PT
DSPIC33EP64MC504T-E/PT
DSPIC33EP64MC204T-E/PTV02
DSPIC33EP64MC504T-E/PTVAO
DSPIC33EP64MC204T-E/PTVAO
DSPIC33EP64MC206T-E/PT
DSPIC33EP64MC506T-E/PT
DSPIC33EP64MC206T-E/PTV08
DSPIC33EP64MC506T-E/PTVAO
DSPIC33EP128MC204-E/TL
DSPIC33EP128MC504-E/TL
DSPIC33EP128MC202-E/MM
DSPIC33EP128GP502-E/MMVAO
DSPIC33EP128GP502-E/SS
DSPIC33EP128MC502-E/SS
DSPIC33EP128MC202-E/SO
DSPIC33EP128GP506-E/MR
DSPIC33EP128MC206-E/MR
DSPIC33EP128MC506-E/MR
DSPIC33EP128GP504-E/MV
DSPIC33EP128MC204-E/MV
DSPIC33EP128MC504-E/MV
DSPIC33EP128MC504-E/MVVAO
DSPIC33EP128GP504-E/ML
DSPIC33EP128MC204-E/ML
DSPIC33EP128MC504-E/ML
DSPIC33EP128MC504-E/MLVAO
DSPIC33EP128MC204-E/PT
DSPIC33EP128MC504-E/PT
DSPIC33EP128GP504-E/PTVAO
DSPIC33EP128MC504-E/PTVAO
DSPIC33EP128MC506-E/PT
DSPIC33EP128GP506-E/PT
DSPIC33EP128MC506-E/PTVAO
DSPIC33EP128GP504-I/TL
DSPIC33EP128MC204-I/TL
DSPIC33EP128MC504-I/TL
DSPIC33EP128GP502-I/MM
DSPIC33EP128MC202-I/MM
DSPIC33EP128MC502-I/MM
DSPIC33EP128GP502-I/SP

DSPIC33EP128MC202-I/SP
DSPIC33EP128MC502-I/SP
DSPIC33EP128GP502-I/SS
DSPIC33EP128MC202-I/SS
DSPIC33EP128MC502-I/SS
DSPIC33EP128GP502-I/SO
DSPIC33EP128MC202-I/SO
DSPIC33EP128MC502-I/SO
DSPIC33EP128GP506-I/MRA3
DSPIC33EP128MC206-I/MRA3
DSPIC33EP128MC506-I/MRA3
DSPIC33EP128GP506-I/MR
DSPIC33EP128MC206-I/MR
DSPIC33EP128MC506-I/MR
DSPIC33EP128GP504-I/MV
DSPIC33EP128MC204-I/MV
DSPIC33EP128MC504-I/MV
DSPIC33EP128GP504-I/ML
DSPIC33EP128MC204-I/ML
DSPIC33EP128MC504-I/ML
DSPIC33EP128MC204-I/PTA3
DSPIC33EP128GP504-I/PT
DSPIC33EP128MC204-I/PT
DSPIC33EP128MC504-I/PT
DSPIC33EP128MC206-I/PTA3
DSPIC33EP128GP506-I/PT
DSPIC33EP128MC206-I/PT
DSPIC33EP128MC506-I/PT
DSPIC33EP128MC206T-H/MR
DSPIC33EP128MC206T-H/MRV10
DSPIC33EP128MC206T-H/MRVAO
DSPIC33EP128MC506T-H/MRVAO
DSPIC33EP128GP504T-H/MV
DSPIC33EP128MC204T-H/MV
DSPIC33EP128MC504T-H/MV
DSPIC33EP128MC504T-H/ML
DSPIC33EP128MC204T-H/MLV11
DSPIC33EP128MC204T-H/MLVAO
DSPIC33EP128MC504T-H/PTV04
DSPIC33EP128MC504T-H/PTV07
DSPIC33EP128MC504T-H/PTVAO
DSPIC33EP128MC506T-H/PTVAO
DSPIC33EP128GP506-H/MR
DSPIC33EP128MC206-H/MR
DSPIC33EP128MC506-H/MR
DSPIC33EP128GP504-H/MV
DSPIC33EP128MC204-H/MV
DSPIC33EP128MC504-H/MV
DSPIC33EP128GP504-H/ML

DSPIC33EP128MC204-H/ML
DSPIC33EP128MC504-H/ML
DSPIC33EP128MC204-H/MLVAO
DSPIC33EP128GP504-H/PT
DSPIC33EP128MC204-H/PT
DSPIC33EP128MC504-H/PT
DSPIC33EP128MC504-H/PTVAO
DSPIC33EP128GP506-H/PT
DSPIC33EP128MC206-H/PT
DSPIC33EP128MC506-H/PT
DSPIC33EP128MC204T-I/TL
DSPIC33EP128MC504T-I/TL
DSPIC33EP128GP502T-I/MM
DSPIC33EP128MC202T-I/MM
DSPIC33EP128MC502T-I/MM
DSPIC33EP128GP502T-I/MMV01
DSPIC33EP128GP502T-I/MMV09
DSPIC33EP128GP506T-I/MR
DSPIC33EP128MC206T-I/MR
DSPIC33EP128MC506T-I/MR
DSPIC33EP128GP504T-I/MV
DSPIC33EP128MC204T-I/MV
DSPIC33EP128MC504T-I/MV
DSPIC33EP128GP504T-I/ML
DSPIC33EP128MC204T-I/ML
DSPIC33EP128MC504T-I/ML
DSPIC33EP128MC204T-I/PTA3
DSPIC33EP128MC204T-I/PT
DSPIC33EP128MC206T-I/PTA3
DSPIC33EP128GP506T-I/PT
DSPIC33EP128MC206T-I/PT
DSPIC33EP128MC506T-I/PT
DSPIC33EP128MC502T-E/MM
DSPIC33EP128MC202T-E/MM
DSPIC33EP128MC202T-E/MMVAO
DSPIC33EP128MC502T-E/SS
DSPIC33EP128GP504T-E/MV
DSPIC33EP128MC204T-E/MV
DSPIC33EP128MC504T-E/MV
DSPIC33EP128GP504T-E/ML
DSPIC33EP128MC204T-E/ML
DSPIC33EP128MC504T-E/ML
DSPIC33EP128MC504T-E/MLVAO
DSPIC33EP128GP504T-E/PTVAO
DSPIC33EP128MC504T-E/PTVAO
DSPIC33EP128MC206T-E/PT
DSPIC33EP128GP506T-E/PTV03
DSPIC33EP128GP506T-E/PTV06
DSPIC33EP128MC506T-E/PTVAO

DSPIC33EP256GP502-E/MM
DSPIC33EP256MC202-E/MM
DSPIC33EP256MC502-E/MM
DSPIC33EP256GP502-E/MMVAO
DSPIC33EP256GP502-E/SP
DSPIC33EP256MC202-E/SP
DSPIC33EP256MC502-E/SP
DSPIC33EP256GP502-E/SS
DSPIC33EP256MC202-E/SS
DSPIC33EP256MC502-E/SS
DSPIC33EP256GP502-E/SO
DSPIC33EP256MC202-E/SO
DSPIC33EP256MC502-E/SO
DSPIC33EP256GP506-E/MR
DSPIC33EP256MC206-E/MR
DSPIC33EP256MC506-E/MR
DSPIC33EP256MC206-E/MRRA3
DSPIC33EP256GP504-E/MV
DSPIC33EP256MC204-E/MV
DSPIC33EP256MC504-E/MV
DSPIC33EP256GP504-E/ML
DSPIC33EP256MC204-E/ML
DSPIC33EP256MC504-E/ML
DSPIC33EP256GP504-E/PT
DSPIC33EP256MC204-E/PT
DSPIC33EP256MC504-E/PTVAO
DSPIC33EP256MC206-E/PT
DSPIC33EP256MC506-E/PT
DSPIC33EP256GP506-E/PTV02
DSPIC33EP256GP506-E/PTV07
DSPIC33EP256MC206-E/PTVAO
DSPIC33EP256MC506-E/PTVAO
DSPIC33EP256GP504-I/TL
DSPIC33EP256MC204-I/TL
DSPIC33EP256MC504-I/TL
DSPIC33EP256GP502-I/MM
DSPIC33EP256MC202-I/MM
DSPIC33EP256MC502-I/MM
DSPIC33EP256GP502-I/SP
DSPIC33EP256MC202-I/SP
DSPIC33EP256MC502-I/SP
DSPIC33EP256GP502-I/SS
DSPIC33EP256MC202-I/SS
DSPIC33EP256MC502-I/SS
DSPIC33EP256GP502-I/SO
DSPIC33EP256MC202-I/SO
DSPIC33EP256MC502-I/SO
DSPIC33EP256GP506-I/MR
DSPIC33EP256MC206-I/MR

DSPIC33EP256MC506-I/MR
DSPIC33EP256GP504-I/MV
DSPIC33EP256MC204-I/MV
DSPIC33EP256MC504-I/MV
DSPIC33EP256GP504-I/ML
DSPIC33EP256MC204-I/ML
DSPIC33EP256MC504-I/ML
DSPIC33EP256GP504-I/PT
DSPIC33EP256MC204-I/PT
DSPIC33EP256MC504-I/PT
DSPIC33EP256MC504-I/PTVAO
DSPIC33EP256GP506-I/PT
DSPIC33EP256MC206-I/PT
DSPIC33EP256MC506-I/PT
DSPIC33EP256MC206-I/PTA3
DSPIC33EP256GP502T-H/MM
DSPIC33EP256MC202T-H/MM
DSPIC33EP256MC502T-H/MM
DSPIC33EP256GP502T-H/SS
DSPIC33EP256MC202T-H/SS
DSPIC33EP256MC502T-H/SS
DSPIC33EP256GP502T-H/SO
DSPIC33EP256MC202T-H/SO
DSPIC33EP256MC502T-H/SO
DSPIC33EP256GP504T-H/MV
DSPIC33EP256MC204T-H/MV
DSPIC33EP256MC504T-H/MV
DSPIC33EP256GP504T-H/ML
DSPIC33EP256MC204T-H/ML
DSPIC33EP256MC504T-H/ML
DSPIC33EP256MC204T-H/MLVAO
DSPIC33EP256GP504T-H/PT
DSPIC33EP256MC204T-H/PT
DSPIC33EP256MC504T-H/PT
DSPIC33EP256MC504T-H/PTV08
DSPIC33EP256MC206T-H/PT
DSPIC33EP256MC506T-H/PT
DSPIC33EP256MC506T-H/PTVAO
DSPIC33EP256GP502-H/MM
DSPIC33EP256MC202-H/MM
DSPIC33EP256MC502-H/MM
DSPIC33EP256GP502-H/SP
DSPIC33EP256MC202-H/SP
DSPIC33EP256MC502-H/SP
DSPIC33EP256GP502-H/SS
DSPIC33EP256MC202-H/SS
DSPIC33EP256MC502-H/SS
DSPIC33EP256GP502-H/SO
DSPIC33EP256MC202-H/SO

DSPIC33EP256MC502-H/SO
DSPIC33EP256GP506-H/MR
DSPIC33EP256GP504-H/MV
DSPIC33EP256MC204-H/MV
DSPIC33EP256MC504-H/MV
DSPIC33EP256GP504-H/ML
DSPIC33EP256MC204-H/ML
DSPIC33EP256MC504-H/ML
DSPIC33EP256MC204-H/MLVAO
DSPIC33EP256MC206-H/PT
DSPIC33EP256MC506-H/PT
DSPIC33EP256MC506-H/PTVAO
DSPIC33EP256GP502T-I/MM
DSPIC33EP256MC202T-I/MM
DSPIC33EP256MC502T-I/MM
DSPIC33EP256GP502T-I/SS
DSPIC33EP256MC202T-I/SS
DSPIC33EP256MC502T-I/SS
DSPIC33EP256GP502T-I/SO
DSPIC33EP256MC202T-I/SO
DSPIC33EP256MC502T-I/SO
DSPIC33EP256GP504T-I/MV
DSPIC33EP256MC204T-I/MV
DSPIC33EP256MC504T-I/MV
DSPIC33EP256GP504T-I/ML
DSPIC33EP256MC204T-I/ML
DSPIC33EP256MC504T-I/ML
DSPIC33EP256MC206T-I/PT
DSPIC33EP256MC506T-I/PT
DSPIC33EP256MC206T-I/PTA3
DSPIC33EP256GP502T-E/MM
DSPIC33EP256MC202T-E/MM
DSPIC33EP256MC502T-E/MM
DSPIC33EP256GP502T-E/SS
DSPIC33EP256MC202T-E/SS
DSPIC33EP256MC502T-E/SS
DSPIC33EP256GP502T-E/SO
DSPIC33EP256MC202T-E/SO
DSPIC33EP256MC502T-E/SO
DSPIC33EP256MC206T-E/MRRA3
DSPIC33EP256GP504T-E/MV
DSPIC33EP256MC204T-E/MV
DSPIC33EP256MC504T-E/MV
DSPIC33EP256MC204T-E/MLC02
DSPIC33EP256GP504T-E/ML
DSPIC33EP256MC204T-E/ML
DSPIC33EP256MC504T-E/ML
DSPIC33EP256MC504T-E/PTVAO
DSPIC33EP256MC206T-E/PT

DSPIC33EP256MC506T-E/PT
DSPIC33EP256GP506T-E/PTV02
DSPIC33EP256GP506T-E/PTV07
DSPIC33EP256MC506T-E/PTV09
DSPIC33EP256MC206T-E/PTV10
DSPIC33EP256MC506T-E/PTVAO
DSPIC33EP32GP502-E/MM
DSPIC33EP32MC202-E/MM
DSPIC33EP32MC502-E/MM
DSPIC33EP32GP502-E/MMVAO
DSPIC33EP32GP502-E/SP
DSPIC33EP32MC202-E/SP
DSPIC33EP32GP502-E/SS
DSPIC33EP32MC202-E/SS
DSPIC33EP32MC502-E/SS
DSPIC33EP32GP502-E/SSVAO
DSPIC33EP32MC502-E/SSVAO
DSPIC33EP32MC202-E/SSVAO
DSPIC33EP32GP502-E/SO
DSPIC33EP32MC202-E/SO
DSPIC33EP32MC502-E/SO
DSPIC33EP32GP504-E/MV
DSPIC33EP32MC204-E/MV
DSPIC33EP32MC504-E/MV
DSPIC33EP32GP503-E/M5
DSPIC33EP32MC503-E/M5
DSPIC33EP32GP504-E/ML
DSPIC33EP32MC204-E/ML
DSPIC33EP32MC504-E/ML
DSPIC33EP32GP504-E/PT
DSPIC33EP32MC204-E/PT
DSPIC33EP32MC504-E/PT
DSPIC33EP32MC204-E/PTA8
DSPIC33EP32MC204-E/PTV01
DSPIC33EP32GP504-E/PTVAO
DSPIC33EP32MC204-E/PTVAO
DSPIC33EP32MC504-E/PTVAO
DSPIC33EP32MC202-I/WC03
DSPIC33EP32GP502-I/MM
DSPIC33EP32MC202-I/MM
DSPIC33EP32MC502-I/MM
DSPIC33EP32GP502-I/SP
DSPIC33EP32MC202-I/SP
DSPIC33EP32MC502-I/SP
DSPIC33EP32GP502-I/SS
DSPIC33EP32MC202-I/SS
DSPIC33EP32MC502-I/SS
DSPIC33EP32GP502-I/SSVAO
DSPIC33EP32MC202-I/SSVAO

DSPIC33EP32GP502-I/SO
DSPIC33EP32MC202-I/SO
DSPIC33EP32MC502-I/SO
DSPIC33EP32GP504-I/MV
DSPIC33EP32MC204-I/MV
DSPIC33EP32MC504-I/MV
DSPIC33EP32GP503-I/M5
DSPIC33EP32MC503-I/M5
DSPIC33EP32GP504-I/ML
DSPIC33EP32MC204-I/ML
DSPIC33EP32MC504-I/ML
DSPIC33EP32GP504-I/PT
DSPIC33EP32MC204-I/PT
DSPIC33EP32MC504-I/PT
DSPIC33EP32MC204-I/PTVAO
DSPIC33EP32MC504-I/PTVAO
DSPIC33EP32MC202T-H/MMVAO
DSPIC33EP32MC202T-H/SSV03
DSPIC33EP32MC202T-H/SSVAO
DSPIC33EP32GP504T-H/MV
DSPIC33EP32MC204T-H/MV
DSPIC33EP32MC504T-H/MV
DSPIC33EP32GP504T-H/ML
DSPIC33EP32MC204T-H/ML
DSPIC33EP32MC504T-H/ML
DSPIC33EP32MC204T-H/MLVAO
DSPIC33EP32GP504T-H/PT
DSPIC33EP32MC204T-H/PT
DSPIC33EP32MC504T-H/PT
DSPIC33EP32MC202-H/MM
DSPIC33EP32MC202-H/MMV04
DSPIC33EP32MC202-H/MMVAO
DSPIC33EP32MC202-H/SS
DSPIC33EP32MC202-H/SSVAO
DSPIC33EP32GP504-H/MV
DSPIC33EP32MC204-H/MV
DSPIC33EP32MC504-H/MV
DSPIC33EP32GP503-H/M5
DSPIC33EP32MC503-H/M5
DSPIC33EP32GP504-H/ML
DSPIC33EP32MC204-H/ML
DSPIC33EP32MC504-H/ML
DSPIC33EP32MC204-H/MLVAO
DSPIC33EP32GP504-H/PT
DSPIC33EP32MC204-H/PT
DSPIC33EP32MC504-H/PT
DSPIC33EP32GP502T-I/MM
DSPIC33EP32MC202T-I/MM
DSPIC33EP32MC502T-I/MM

DSPIC33EP32GP502T-I/SS
DSPIC33EP32MC202T-I/SS
DSPIC33EP32GP502T-I/SSVAO
DSPIC33EP32MC202T-I/SSVAO
DSPIC33EP32GP502T-I/SO
DSPIC33EP32MC202T-I/SO
DSPIC33EP32MC502T-I/SO
DSPIC33EP32GP504T-I/MV
DSPIC33EP32MC204T-I/MV
DSPIC33EP32MC504T-I/MV
DSPIC33EP32GP504T-I/ML
DSPIC33EP32MC204T-I/ML
DSPIC33EP32MC504T-I/ML
DSPIC33EP32GP504T-I/PT
DSPIC33EP32MC204T-I/PT
DSPIC33EP32MC504T-I/PT
DSPIC33EP32MC204T-I/PTVAO
DSPIC33EP32GP502T-E/MM
DSPIC33EP32MC202T-E/MM
DSPIC33EP32MC502T-E/MM
DSPIC33EP32GP502T-E/MMVAO
DSPIC33EP32GP502T-E/SS
DSPIC33EP32MC202T-E/SS
DSPIC33EP32MC502T-E/SS
DSPIC33EP32MC202T-E/SSV02
DSPIC33EP32GP502T-E/SSVAO
DSPIC33EP32MC502T-E/SSVAO
DSPIC33EP32MC202T-E/SSVAO
DSPIC33EP32GP502T-E/SO
DSPIC33EP32MC502T-E/SO
DSPIC33EP32GP504T-E/MV
DSPIC33EP32MC204T-E/MV
DSPIC33EP32MC504T-E/MV
DSPIC33EP32GP504T-E/ML
DSPIC33EP32MC204T-E/ML
DSPIC33EP32MC504T-E/ML
DSPIC33EP32GP504T-E/PT
DSPIC33EP32MC204T-E/PT
DSPIC33EP32MC204T-E/PTV01
DSPIC33EP32GP504T-E/PTVAO
DSPIC33EP32MC204T-E/PTVAO
PIC24EP512GP202-E/MM
PIC24EP512GP202-E/SP
PIC24EP512MC202-E/SP
PIC24EP512GP202-E/SO
PIC24EP512GP206-E/MR
PIC24EP512MC206-E/MR
PIC24EP512GP204-E/MV
PIC24EP512MC204-E/MV

PIC24EP512GP204-E/ML
PIC24EP512MC204-E/ML
PIC24EP512GP206-E/PT
PIC24EP512GP202-I/MM
PIC24EP512MC202-I/MM
PIC24EP512GP202-I/SP
PIC24EP512MC202-I/SP
PIC24EP512GP202-I/SO
PIC24EP512MC202-I/SO
PIC24EP512GP206-I/MR
PIC24EP512MC206-I/MR
PIC24EP512GP204-I/MV
PIC24EP512MC204-I/MV
PIC24EP512GP204-I/ML
PIC24EP512MC204-I/ML
PIC24EP512GP204-I/PT
PIC24EP512MC204-I/PT
PIC24EP512GP206-I/PT
PIC24EP512MC206-I/PT
PIC24EP512GP204T-H/TL
PIC24EP512MC204T-H/TL
PIC24EP512GP202T-H/MM
PIC24EP512MC202T-H/MM
PIC24EP512GP206T-H/MR
PIC24EP512MC206T-H/MR
PIC24EP512GP204T-H/MV
PIC24EP512MC204T-H/MV
PIC24EP512GP204T-H/ML
PIC24EP512MC204T-H/ML
PIC24EP512GP204T-H/PT
PIC24EP512MC204T-H/PT
PIC24EP512MC206T-H/PT
PIC24EP512GP206T-H/PT
PIC24EP512GP204-H/TL
PIC24EP512MC204-H/TL
PIC24EP512GP202-H/MM
PIC24EP512MC202-H/MM
PIC24EP512MC202-H/SO
PIC24EP512GP206-H/MR
PIC24EP512MC206-H/MR
PIC24EP512GP204-H/MV
PIC24EP512MC204-H/MV
PIC24EP512GP204-H/ML
PIC24EP512MC204-H/ML
PIC24EP512GP204-H/PT
PIC24EP512MC204-H/PT
PIC24EP512GP206-H/PT
PIC24EP512MC206-H/PT
PIC24EP512GP206T-I/MR

PIC24EP512MC206T-I/MR
PIC24EP512GP204T-I/MV
PIC24EP512MC204T-I/MV
PIC24EP512GP204T-I/ML
PIC24EP512MC204T-I/ML
PIC24EP512GP204T-I/PT
PIC24EP512GP206T-E/MR
PIC24EP512MC206T-E/MR
PIC24EP512GP204T-E/ML
PIC24EP512MC204T-E/ML
PIC24EP64MC204-E/TL
PIC24EP64MC203-E/TL
PIC24EP64GP202-E/MM
PIC24EP64MC202-E/MM
PIC24EP64MC202-E/SP
PIC24EP64MC202-E/SS
PIC24EP64GP202-E/SO
PIC24EP64MC202-E/SO
PIC24EP64GP206-E/MR
PIC24EP64MC206-E/MR
PIC24EP64GP204-E/MV
PIC24EP64MC204-E/MV
PIC24EP64GP203-E/M5
PIC24EP64MC203-E/M5
PIC24EP64GP204-E/ML
PIC24EP64MC204-E/ML
PIC24EP64GP204-E/PT
PIC24EP64MC204-E/PT
PIC24EP64GP206-E/PT
PIC24EP64MC206-E/PT
PIC24EP64MC204-I/TL
PIC24EP64GP203-I/TL
PIC24EP64MC203-I/TL
PIC24EP64GP202-I/MM
PIC24EP64MC202-I/MM
PIC24EP64GP202-I/SP
PIC24EP64MC202-I/SP
PIC24EP64GP202-I/SS
PIC24EP64MC202-I/SS
PIC24EP64GP202-I/SO
PIC24EP64MC202-I/SO
PIC24EP64GP206-I/MRA3
PIC24EP64GP206-I/MR
PIC24EP64MC206-I/MR
PIC24EP64GP204-I/MV
PIC24EP64MC204-I/MV
PIC24EP64GP203-I/M5
PIC24EP64MC203-I/M5
PIC24EP64GP204-I/ML

PIC24EP64MC204-I/ML
PIC24EP64GP204-I/PTC03
PIC24EP64MC204-I/PTC06
PIC24EP64GP204-I/PT
PIC24EP64MC204-I/PT
PIC24EP64GP206-I/PT
PIC24EP64MC206-I/PT
PIC24EP64GP202T-H/MM
PIC24EP64MC202T-H/MM
PIC24EP64GP206T-H/MR
PIC24EP64MC206T-H/MR
PIC24EP64GP204T-H/MV
PIC24EP64MC204T-H/MV
PIC24EP64GP204T-H/ML
PIC24EP64MC204T-H/ML
PIC24EP64GP202-H/MM
PIC24EP64MC202-H/MM
PIC24EP64GP206-H/MR
PIC24EP64MC206-H/MR
PIC24EP64GP204-H/MV
PIC24EP64MC204-H/MV
PIC24EP64GP203-H/M5
PIC24EP64MC203-H/M5
PIC24EP64GP204-H/ML
PIC24EP64MC204-H/ML
PIC24EP64MC204T-I/TL
PIC24EP64MC203T-I/TL
PIC24EP64GP202T-I/MM
PIC24EP64MC202T-I/MM
PIC24EP64GP202T-I/SS
PIC24EP64MC202T-I/SS
PIC24EP64MC202T-I/SO
PIC24EP64GP206T-I/MR
PIC24EP64MC206T-I/MR
PIC24EP64GP204T-I/MV
PIC24EP64MC204T-I/MV
PIC24EP64GP204T-I/ML
PIC24EP64MC204T-I/ML
PIC24EP64GP204T-I/PT
PIC24EP64MC204T-I/PT
PIC24EP64MC206T-I/PT
PIC24EP64MC204T-E/TL
PIC24EP64MC202T-E/MM
PIC24EP64MC202T-E/SS
PIC24EP64MC202T-E/SO
PIC24EP64GP206T-E/MR
PIC24EP64MC206T-E/MR
PIC24EP64GP204T-E/MV
PIC24EP64MC204T-E/MV

PIC24EP64GP204T-E/ML
PIC24EP64MC204T-E/ML
PIC24EP64MC204T-E/PT
PIC24EP64MC206T-E/PT
PIC24EP128GP202-E/MM
PIC24EP128GP206-E/MR
PIC24EP128MC206-E/MR
PIC24EP128GP204-E/MV
PIC24EP128MC204-E/MV
PIC24EP128GP204-E/ML
PIC24EP128MC204-E/ML
PIC24EP128GP204-E/PT
PIC24EP128GP204-E/PTVAO
PIC24EP128GP204-I/TL
PIC24EP128MC204-I/TL
PIC24EP128GP202-I/MM038
PIC24EP128GP202-I/MM
PIC24EP128GP202-I/SP
PIC24EP128MC202-I/SP
PIC24EP128GP202-I/SS
PIC24EP128MC202-I/SS
PIC24EP128GP202-I/SO
PIC24EP128MC202-I/SO
PIC24EP128GP206-I/MR022
PIC24EP128GP206-I/MRA3
PIC24EP128MC206-I/MRA3
PIC24EP128GP206-I/MR
PIC24EP128MC206-I/MR
PIC24EP128GP204-I/MV029
PIC24EP128GP204-I/MV
PIC24EP128MC204-I/MV
PIC24EP128GP204-I/ML
PIC24EP128MC204-I/ML
PIC24EP128GP204-I/PT030
PIC24EP128GP204-I/PT035
PIC24EP128GP204-I/PT037
PIC24EP128GP204-I/PT
PIC24EP128MC204-I/PT
PIC24EP128GP206-I/PT
PIC24EP128MC206-I/PT
PIC24EP128GP206-I/PTV08
PIC24EP128GP206-I/PTVAO
PIC24EP128GP204T-H/MV
PIC24EP128MC204T-H/MV
PIC24EP128GP206-H/MR
PIC24EP128MC206-H/MR
PIC24EP128GP204-H/MV
PIC24EP128MC204-H/MV
PIC24EP128GP204-H/ML

PIC24EP128MC204-H/ML
PIC24EP128GP204-H/PT
PIC24EP128MC204-H/PT
PIC24EP128GP206-H/PT
PIC24EP128MC206-H/PT
PIC24EP128GP202T-I/MM020
PIC24EP128GP202T-I/MM021
PIC24EP128GP202T-I/MM027
PIC24EP128GP202T-I/MM038
PIC24EP128GP202T-I/MMV02
PIC24EP128GP202T-I/MMV05
PIC24EP128GP202T-I/SS
PIC24EP128GP206T-I/MR022
PIC24EP128GP206T-I/MR
PIC24EP128MC206T-I/MR
PIC24EP128GP204T-I/MV029
PIC24EP128GP204T-I/MV
PIC24EP128MC204T-I/MV
PIC24EP128GP204T-I/ML
PIC24EP128MC204T-I/ML
PIC24EP128GP204T-I/PT030
PIC24EP128GP204T-I/PT032
PIC24EP128GP204T-I/PT033
PIC24EP128GP204T-I/PT035
PIC24EP128GP204T-I/PT037
PIC24EP128GP204T-I/PT
PIC24EP128GP206T-I/PT
PIC24EP128GP206T-I/PTV08
PIC24EP128GP206T-I/PTVAO
PIC24EP128GP202T-E/SS
PIC24EP128GP204T-E/MV
PIC24EP128MC204T-E/MV
PIC24EP128GP204T-E/PTVAO
PIC24EP256GP204-E/TL
PIC24EP256GP202-E/MM
PIC24EP256MC202-E/MM
PIC24EP256GP202-E/SP
PIC24EP256MC202-E/SP
PIC24EP256GP202-E/SS
PIC24EP256MC202-E/SS
PIC24EP256GP202-E/SO
PIC24EP256MC202-E/SO
PIC24EP256GP206-E/MR
PIC24EP256GP204-E/MV
PIC24EP256MC204-E/MV
PIC24EP256GP204-E/ML
PIC24EP256MC204-E/ML
PIC24EP256GP204-E/PT
PIC24EP256MC204-E/PT

PIC24EP256GP204-E/PTVAO
PIC24EP256GP206-E/PT
PIC24EP256GP204-I/TL
PIC24EP256MC204-I/TL
PIC24EP256GP202-I/MM
PIC24EP256MC202-I/MM
PIC24EP256GP202-I/SP
PIC24EP256MC202-I/SP
PIC24EP256GP202-I/SS
PIC24EP256MC202-I/SS
PIC24EP256GP202-I/SO
PIC24EP256MC202-I/SO
PIC24EP256GP206-I/MR
PIC24EP256MC206-I/MR
PIC24EP256GP204-I/MV
PIC24EP256MC204-I/MV
PIC24EP256GP204-I/ML
PIC24EP256MC204-I/ML
PIC24EP256GP204-I/PT
PIC24EP256MC204-I/PT
PIC24EP256GP206-I/PT
PIC24EP256MC206-I/PT
PIC24EP256GP202T-H/MM
PIC24EP256MC202T-H/MM
PIC24EP256GP202T-H/SS
PIC24EP256MC202T-H/SS
PIC24EP256GP202T-H/SO
PIC24EP256MC202T-H/SO
PIC24EP256GP204T-H/MV
PIC24EP256MC204T-H/MV
PIC24EP256GP204T-H/ML
PIC24EP256MC204T-H/ML
PIC24EP256GP204T-H/PT
PIC24EP256MC204T-H/PT
PIC24EP256GP202-H/MM
PIC24EP256MC202-H/MM
PIC24EP256GP202-H/SP
PIC24EP256MC202-H/SP
PIC24EP256GP202-H/SS
PIC24EP256MC202-H/SS
PIC24EP256GP202-H/SO
PIC24EP256MC202-H/SO
PIC24EP256GP204-H/MV
PIC24EP256MC204-H/MV
PIC24EP256GP204-H/ML
PIC24EP256MC204-H/ML
PIC24EP256GP202T-I/MM
PIC24EP256MC202T-I/MM
PIC24EP256GP202T-I/MMV01

PIC24EP256GP202T-I/MMV05
PIC24EP256GP202T-I/SS
PIC24EP256MC202T-I/SS
PIC24EP256GP202T-I/SO
PIC24EP256MC202T-I/SO
PIC24EP256GP206T-I/MR
PIC24EP256MC206T-I/MR
PIC24EP256GP204T-I/MV030
PIC24EP256GP204T-I/MV
PIC24EP256MC204T-I/MV
PIC24EP256GP204T-I/ML029
PIC24EP256GP204T-I/ML
PIC24EP256MC204T-I/ML
PIC24EP256GP204T-I/PT
PIC24EP256MC204T-I/PT
PIC24EP256GP206T-I/PT
PIC24EP256MC206T-I/PT
PIC24EP256GP206T-I/PTV03
PIC24EP256GP206T-I/PTV06
PIC24EP256GP202T-E/MM
PIC24EP256MC202T-E/MM
PIC24EP256GP202T-E/SS
PIC24EP256MC202T-E/SS
PIC24EP256GP202T-E/SO
PIC24EP256MC202T-E/SO
PIC24EP256GP204T-E/MV
PIC24EP256MC204T-E/MV
PIC24EP256GP204T-E/ML
PIC24EP256MC204T-E/ML
PIC24EP256GP204T-E/PTVAO
PIC24EP256GP206T-E/PT
PIC24EP32MC202-E/MM021
PIC24EP32GP202-E/MM
PIC24EP32MC202-E/MM
PIC24EP32GP202-E/SP
PIC24EP32MC202-E/SP
PIC24EP32GP202-E/SS
PIC24EP32MC202-E/SS
PIC24EP32GP202-E/SO
PIC24EP32MC202-E/SO
PIC24EP32GP204-E/MV
PIC24EP32MC204-E/MV
PIC24EP32GP203-E/M5
PIC24EP32MC203-E/M5
PIC24EP32GP204-E/ML
PIC24EP32MC204-E/ML
PIC24EP32GP204-E/PT
PIC24EP32GP202-I/MM
PIC24EP32MC202-I/MM

PIC24EP32GP202-I/SP
PIC24EP32MC202-I/SP
PIC24EP32GP202-I/SS
PIC24EP32MC202-I/SS
PIC24EP32GP202-I/SO
PIC24EP32MC202-I/SO
PIC24EP32GP204-I/MV
PIC24EP32MC204-I/MV
PIC24EP32GP203-I/M5
PIC24EP32MC203-I/M5
PIC24EP32GP204-I/ML
PIC24EP32MC204-I/ML
PIC24EP32GP204-I/PT
PIC24EP32MC204-I/PT
PIC24EP32GP204T-H/MV
PIC24EP32MC204T-H/MV
PIC24EP32GP204T-H/ML
PIC24EP32MC204T-H/ML
PIC24EP32GP204T-H/PT
PIC24EP32MC204T-H/PT
PIC24EP32GP204-H/MV
PIC24EP32MC204-H/MV
PIC24EP32GP203-H/M5
PIC24EP32MC203-H/M5
PIC24EP32GP204-H/ML
PIC24EP32MC204-H/ML
PIC24EP32GP204-H/PT
PIC24EP32MC204-H/PT
PIC24EP32GP202T-I/MM
PIC24EP32GP202T-I/SS
PIC24EP32GP202T-I/SO
PIC24EP32GP204T-I/MV
PIC24EP32MC204T-I/MV
PIC24EP32GP204T-I/ML
PIC24EP32MC204T-I/ML
PIC24EP32GP204T-I/PT
PIC24EP32MC202T-E/MM021
PIC24EP32GP202T-E/MM
PIC24EP32GP202T-E/SS
PIC24EP32MC202T-E/SS
PIC24EP32GP202T-E/SO
PIC24EP32GP204T-E/MV
PIC24EP32MC204T-E/MV
PIC24EP32GP204T-E/ML
PIC24EP32MC204T-E/ML
PIC24EP32GP204T-E/PT



dsPIC33EPXXXGP50X, dsPIC33EPXXXMC20X/50X and PIC24EPXXXGP/MC20X

dsPIC33EPXXXGP50X, dsPIC33EPXXXMC20X/50X and PIC24EPXXXGP/MC20X Family Silicon Errata and Data Sheet Clarification

The dsPIC33EPXXXGP50X, dsPIC33EPXXXMC20X/50X and PIC24EPXXXGP/MC20X family devices that you have received conform functionally to the current Device Data Sheet (DS70000657J), except for the anomalies described in this document.

The silicon issues discussed in the following pages are for silicon revisions with the Device and Revision IDs listed in [Table 1](#). The silicon issues are summarized in [Table 2](#).

The errata described in this document will be addressed in future revisions of dsPIC33EPXXXGP50X, dsPIC33EPXXXMC20X/50X and PIC24EPXXXGP/MC20X silicon.

Data Sheet clarifications and corrections start on [Page 27](#), following the discussion of silicon issues.

The silicon revision level can be identified using the current version of MPLAB® IDE and Microchip's programmers, debuggers and emulation tools, which are available at the Microchip corporate website (www.microchip.com).

For example, to identify the silicon revision level using MPLAB IDE in conjunction with MPLAB ICD 3 or PICKIT™ 3:

1. Using the appropriate interface, connect the device to the MPLAB ICD 3 programmer/debugger or PICKIT 3.
2. From the main menu in MPLAB IDE, select *Configure>Select Device*, and then select the target part number in the dialog box.
3. Select the MPLAB hardware tool (*Debugger>Select Tool*).
4. Perform a "Connect" operation to the device (*Debugger>Connect*). Depending on the development tool used, the part number *and* Device Revision ID value appear in the **Output** window.

Note: This document summarizes all silicon errata issues from the revisions of silicon, previous as well as current. The released silicon revision levels are:

dsPIC33/PIC24EP32	A3, A8
dsPIC33/PIC24EP64	A2, A3, A8
dsPIC33/PIC24EP128	A3, A8
dsPIC33/PIC24EP256	A3, A8, A9
dsPIC33/PIC24EP512	A7

Note: If you are unable to extract the silicon revision level, please contact your local Microchip sales office for assistance.

Note: The current silicon revision levels are identified by shaded columns:

Device	A2	A3	A7	A8	A9
dsPIC33/PIC24EP32					
dsPIC33/PIC24EP64					
dsPIC33/PIC24EP128					
dsPIC33/PIC24EP256					
dsPIC33/PIC24EP512					

The Device and Revision ID values for the various silicon revisions are shown in [Table 1](#).

TABLE 1: SILICON DEVREV VALUES

Part Number	Device ID ⁽¹⁾	Silicon Revision/Device ID ⁽²⁾							
PIC24EP32GP202	0x1C19	—	A3 0x4003	A8 0x4008	—				
PIC24EP32GP203	0x1C1A								
PIC24EP32GP204	0x1C18								
dsPIC33EP32GP502	0x1C0D								
dsPIC33EP32GP503	0x1C0E								
dsPIC33EP32GP504	0x1C0C								
PIC24EP32MC202	0x1C11								
PIC24EP32MC203	0x1C12								
PIC24EP32MC204	0x1C10								
dsPIC33EP32MC202	0x1C01								
dsPIC33EP32MC203	0x1C02								
dsPIC33EP32MC204	0x1C00								
dsPIC33EP32MC502	0x1C05								
dsPIC33EP32MC503	0x1C06								
dsPIC33EP32MC504	0x1C04								
dsPIC33EP32MC506	0x1D27								
PIC24EP64GP202	0x1D39					A2 0x4002	A3 0x4003	A8 0x4008	—
PIC24EP64GP203	0x1D3A								
PIC24EP64GP204	0x1D38								
PIC24EP64GP206	0x1D3B								
dsPIC33EP64GP502	0x1D2D								
dsPIC33EP64GP503	0x1D2E								
dsPIC33EP64GP504	0x1D2C								
dsPIC33EP64GP506	0x1D2F								
PIC24EP64MC202	0x1D31								
PIC24EP64MC203	0x1D32								
PIC24EP64MC204	0x1D30								
PIC24EP64MC206	0x1D33								
dsPIC33EP64MC202	0x1D21								
dsPIC33EP64MC203	0x1D22								
dsPIC33EP64MC204	0x1D20								
dsPIC33EP64MC206	0x1D23								
dsPIC33EP64MC502	0x1D25								
dsPIC33EP64MC503	0x1D26								
dsPIC33EP64MC504	0x1D24								
dsPIC33EP64MC506	0x1D27								

Note 1: The Device and Revision IDs (DEVID and DEVREV) are located at the last two implemented addresses in program memory.

2: Refer to the “dsPIC33E/PIC24E Flash Programming Specification for Devices with Volatile Configuration Bits” (DS70663) for detailed information on Device and Revision IDs for your specific device.

TABLE 1: SILICON DEVREV VALUES (CONTINUED)

Part Number	Device ID ⁽¹⁾	Silicon Revision/Device ID ⁽²⁾			
PIC24EP128GP202	0x1E59	—	A3 0x4003	A8 0x4008	—
PIC24EP128GP204	0x1E58				
PIC24EP128GP206	0x1E5B				
dsPIC33EP128GP502	0x1E4D				
dsPIC33EP128GP504	0x1E4C				
dsPIC33EP128GP506	0x1E4F				
PIC24EP128MC202	0x1E51				
PIC24EP128MC204	0x1E50				
PIC24EP128MC206	0x1E53				
dsPIC33EP128MC202	0x1E41				
dsPIC33EP128MC204	0x1E40				
dsPIC33EP128MC206	0x1E43				
dsPIC33EP128MC502	0x1E45				
dsPIC33EP128MC504	0x1E44				
dsPIC33EP128MC506	0x1E47				
PIC24EP256GP202	0x1F79				
PIC24EP256GP204	0x1F78				
PIC24EP256GP206	0x1F7B				
dsPIC33EP256GP502	0x1F6D				
dsPIC33EP256GP504	0x1F6C				
dsPIC33EP256GP506	0x1F6F				
PIC24EP256MC202	0x1F71				
PIC24EP256MC204	0x1F70				
PIC24EP256MC206	0x1F73				
dsPIC33EP256MC202	0x1F61				
dsPIC33EP256MC204	0x1F60				
dsPIC33EP256MC206	0x1F63				
dsPIC33EP256MC502	0x1F65				
dsPIC33EP256MC504	0x1F64				
dsPIC33EP256MC506	0x1F67				

Note 1: The Device and Revision IDs (DEVID and DEVREV) are located at the last two implemented addresses in program memory.

2: Refer to the “dsPIC33E/PIC24E Flash Programming Specification for Devices with Volatile Configuration Bits” (DS70663) for detailed information on Device and Revision IDs for your specific device.

TABLE 1: SILICON DEVREV VALUES (CONTINUED)

Part Number	Device ID ⁽¹⁾	Silicon Revision/Device ID ⁽²⁾			
PIC24EP512GP202	0x1799	—	A7 0x4007	—	—
PIC24EP512GP204	0x1798				
PIC24EP512GP206	0x179B				
dsPIC33EP512GP502	0x178D				
dsPIC33EP512GP504	0x178C				
dsPIC33EP512GP506	0x178F				
PIC24EP512MC202	0x1791				
PIC24EP512MC204	0x1790				
PIC24EP512MC206	0x1793				
dsPIC33EP512MC202	0x1781				
dsPIC33EP512MC204	0x1780				
dsPIC33EP512MC206	0x1783				
dsPIC33EP512MC502	0x1785				
dsPIC33EP512MC504	0x1784				
dsPIC33EP512MC506	0x1787				

- Note 1:** The Device and Revision IDs (DEVID and DEVREV) are located at the last two implemented addresses in program memory.
- 2:** Refer to the “*dsPIC33E/PIC24E Flash Programming Specification for Devices with Volatile Configuration Bits*” (DS70663) for detailed information on Device and Revision IDs for your specific device.

TABLE 2: SILICON ISSUE SUMMARY

Module	Feature	Item Number	Issue Summary
CPU	div.sd	1.	When using the div.sd instruction, the Overflow bit is not getting set when an overflow occurs.
CPU	DO Loop	2.	PSV access, including Table Reads or Writes in the first or last instruction of a DO loop, is not allowed.
SPI	Frame Sync Pulse	3.	Frame Sync pulse is not generated in Master mode when FRMPOL = 0.
SPI	Frame Sync Pulse	4.	When in SPI Slave mode, with the Frame Sync pulse set as an input, FRMDLY must be set to '0'.
UART	TX Interrupt	5.	A Transmit (TX) interrupt may occur before the data transmission is complete.
Power System	Flash Regulator	6.	The VREGSF (RCON[11]) bit always reads back as '0'.
ADC	DONE bit	7.	The ADC Conversion Status bit (DONE) does not work when an external interrupt is selected as the ADC trigger source.
PTG	Strobe Output	8.	Strobe output pulse width is incorrectly dependent on the PTGPWD[3:0] (PTGCON[7:4]) bits setting.
Op Amp	Enabling Op Amp mode	9.	When using any of these op amp modules, or Analog Channels AN0, AN3 or AN6, to sample external signals, bit 11 of the CMxCON register must be set to '1'.
Op Amp	AC/DC Electrical Characteristics	10.	The AC/DC electrical characteristics for the op amp module (and the related ADC specifications) are not within the specifications published in the current data sheet.
PWM	Dead-Time Compensation	11.	Dead-time compensation is not enabled for Center-Aligned PWM mode.
Flash	Flash Programming	12.	The Stall mechanism may not function properly when erasing or programming Flash memory.
QEI	Index Counter	13.	The QEI Index Counter does not count correctly in Quadrature Detector mode.
QEI	Modulo Mode	14.	Modulo mode functionality is incorrect when the count polarity bit is set.
PWM	Master Time Base Mode	15.	In Master Time Base mode, writing to the period register and any other timing parameter of the PWMx module, will cause the update of the other timing parameter to take effect one PWM cycle after the period update is effective.
ADC	1.1 Msps Sampling	16.	Selecting the same ANx input (AN0 or AN3) for CH0 and CH1 to achieve a 1.1 Msps sampling rate results in erroneous readings for CH1.
ADC	Channel Scan	17.	Channel scanning is limited to AN0 through AN15.
Output Compare	Interrupt	18.	Under certain circumstances, an output compare match may cause the Output Compare x Interrupt Flag (OCxIF) bit to become set prior to the Change-of-State (COS) of the OCx pin.
CAN	DMA	19.	Write collisions on a DMA-enabled CAN module does not generate DMAC error traps.
PWM	Immediate Update	20.	Dead time is not asserted when PDCx is updated to cause an immediate transition on the PWMxH and PWMxL outputs.
PWM	Center-Aligned Mode	21.	PWMxH is asserted for 100% of the PWM period in Complementary mode under certain circumstances.
PWM	Complementary Mode	22.	With dead time greater than zero, 0% and 100% duty cycle cannot be obtained on PWMxL and PWMxH outputs.

TABLE 2: SILICON ISSUE SUMMARY (CONTINUED)

Module	Feature	Item Number	Issue Summary
CPU	Program Memory	23.	Address error trap may occur while accessing certain program memory locations.
PWM	Center-Aligned Mode	24.	Updates to active MDC/PDCx/ALTDTRx/PHASEx registers occur only once every two PWM periods.
PWM	Independent Time Base Mode	25.	Under certain circumstances, updates to the OVRENH and OVRENL bits may be ignored by the PWMx module.
PWM	Center-Aligned Mode	26.	PHASEx register updates are delayed.
CTMU	ADC Operation	27.	CTMU does not work with the ADC Converter in 12-bit mode.
Input Capture	External Synchronization	28.	Input capture and output compare modules cannot be synchronized.
JTAG	—	29.	—
I/O	Pin Functions that are Not 5V Tolerant	30.	Select pins are not 5V tolerant.
JTAG	I/O	31.	Active-high logic pulse on the I/O pin with TMS function at POR.
QE1	Velocity Counter	32.	Under certain circumstances, the Velocity Counter 1 register (VEL1CNT) misses count pulses.
QE1	Position Capture	33.	Under certain conditions, the captured position may be off by ± 1 count.
QE1	Position Capture	34.	Position count captured at the rising edge of the HOME signal and not the INDEX signal.
PWM	Center-Aligned Mode	35.	Under certain conditions, PWMxH and PWMxL are deasserted.
PWM	Current Reset Mode	36.	When the PWM generator is configured to operate in Current Reset mode, the PWM Reset will happen only in every alternate PWM cycle.
Op Amp/Comparator	External Reference	37.	Op Amp/Comparator Voltage Reference fails when the voltage on VREF+ is less than 1.33V.
PWM	PWM Override	38.	Glitch on PWMxH or PWMxL pins when override is turned off.
PWM	PWM SWAP	39.	When in Complementary mode, PWM SWAP feature does not function properly.
PWM	PWM Override	40.	PWM override feature is not functional.
CAN	Receive Buffer	41.	Read-Modify-Write operation on a CxRXFULx register may not update it correctly.
PWM	Edge-Aligned Mode	42.	Missing dead time under certain conditions.
PWM	Output Modes	43.	Output glitch pulse.
PWM	Complementary Output Mode	44.	Missing dead time between complementary outputs under certain conditions.
PWM	PWM SWAP	45.	In Center-Aligned mode, there is missing dead time when SWAP is disabled.
PWM	Center-Aligned Mode	46.	Updates to the PHASEx registers occur only at the middle of the Center-Aligned PWM cycle.
CPU	Data Flash Reads	47.	Given a specific set of preconditions, when two or more data Flash read instructions (via Program Space Visibility (PSV) read or Table Read) are executed back-to-back, one or more subsequent instructions will be misexecuted.

Silicon Errata Issues

Note: This document summarizes all silicon errata issues from all revisions of silicon, previous as well as current. The **Affected Families and Silicon Revisions** tables display an X when a silicon revision is affected by the silicon errata issue. If a cell is empty, the corresponding silicon revision either is not available or is not affected by the errata.

1. Module: CPU

When using the Signed 32-by-16-bit Division instruction, `div.sd`, the overflow bit does not always get set when an overflow occurs.

Work around

Test for and handle overflow conditions outside of the `div.sd` instruction.

Affected Families and Silicon Revisions

Device	A2	A3	A7	A8	A9
dsPIC33/PIC24EP32		X		X	
dsPIC33/PIC24EP64	X	X		X	
dsPIC33/PIC24EP128		X		X	
dsPIC33/PIC24EP256		X		X	X
dsPIC33/PIC24EP512			X		

2. Module: CPU

Table Write (`TBLWTx`), Table Read (`TBLRDx`) and PSV Flash read instructions should not be used in the first or last instruction locations of a `DO` loop.

Work around

None.

Affected Families and Silicon Revisions

Device	A2	A3	A7	A8	A9
dsPIC33/PIC24EP32		X		X	
dsPIC33/PIC24EP64	X	X		X	
dsPIC33/PIC24EP128		X		X	
dsPIC33/PIC24EP256		X		X	X
dsPIC33/PIC24EP512			X		

3. Module: SPI

When using the Frame Sync pulse output feature (FRMEN bit (`SPIxCON2[15]`) = 1) in Master mode (SPIFSD bit (`SPIxCON2[14]`) = 0), the Frame Sync pulse is not being generated with an active-low pulse (FRMPOL bit (`SPIxCON2[13]`) = 0).

Work around

The `SSx` pin is used as the Frame Sync pulse when the Frame Sync pulse output feature is used. Mapping the `SSx` input function and output function to the same pad, by using the Peripheral Pin Select (PPS) feature, resolves this issue.

Affected Families and Silicon Revisions

Device	A2	A3	A7	A8	A9
dsPIC33/PIC24EP32		X		X	
dsPIC33/PIC24EP64	X	X		X	
dsPIC33/PIC24EP128		X		X	
dsPIC33/PIC24EP256		X		X	X
dsPIC33/PIC24EP512			X		

4. Module: SPI

When in SPI Slave mode (MSTEN bit (`SPIxCON1[5]`) = 0) and using the Frame Sync pulse output feature (FRMEN bit (`SPIxCON2[15]`) = 1) in Slave mode (SPIFSD bit (`SPIxCON2[14]`) = 1), the Frame Sync Pulse Edge Select bit must be set to '0' (FRMDLY bit (`SPIxCON2[1]`) = 0).

Work around

There is no work around. The Frame Sync Pulse Edge Select bit, FRMDLY, cannot be set to produce a Frame Sync pulse that coincides with the first bit clock.

Affected Families and Silicon Revisions

Device	A2	A3	A7	A8	A9
dsPIC33/PIC24EP32		X		X	
dsPIC33/PIC24EP64	X	X		X	
dsPIC33/PIC24EP128		X		X	
dsPIC33/PIC24EP256		X		X	X
dsPIC33/PIC24EP512			X		

5. Module: UART

When using `UTXISEL[1:0] = 01` (interrupt when last character is shifted out of the Transmit Shift Register) and the final character is being shifted out through the Transmit Shift Register (TSR), the Transmit (TX) interrupt may occur before the final bit is shifted out.

Work around

If it is critical that the interrupt processing occurs only when all transmit operations are complete. Hold off the interrupt routine processing by adding a loop at the beginning of the routine that polls the Transmit Shift Register Empty bit (TRMT) before processing the rest of the interrupt.

Affected Families and Silicon Revisions

Device	A2	A3	A7	A8	A9
dsPIC33/PIC24EP32		X		X	
dsPIC33/PIC24EP64	X	X		X	
dsPIC33/PIC24EP128		X		X	
dsPIC33/PIC24EP256		X		X	X
dsPIC33/PIC24EP512			X		

6. Module: Power System

The VREGSF bit functions as documented, but will always read back as '0'. Because of the Read-Modify-Write process, any `BSET` or `BCLR` instruction of the RCON register will also write a '0' to the VREGSF bit.

Work around

If the VREGSF bit is intended to be set to '1', the user software must also write a '1' to the VREGSF bit when setting or clearing any other bit in the RCON register.

Affected Families and Silicon Revisions

Device	A2	A3	A7	A8	A9
dsPIC33/PIC24EP32		X		X	
dsPIC33/PIC24EP64	X	X		X	
dsPIC33/PIC24EP128		X		X	
dsPIC33/PIC24EP256		X		X	X
dsPIC33/PIC24EP512			X		

7. Module: ADC

The ADC Conversion Status (DONE) bit (`ADxCON1[0]`) does not indicate completion of conversion when an external interrupt is selected as the ADC trigger source (`SSRC[2:0]` bits (`AD1CON1[7:5] = 0x1`)).

Work around

Use an ADC interrupt or poll the `ADxIF` bit in the `IFSx` registers to determine the completion of conversion.

Affected Families and Silicon Revisions

Device	A2	A3	A7	A8	A9
dsPIC33/PIC24EP32		X		X	
dsPIC33/PIC24EP64	X	X		X	
dsPIC33/PIC24EP128		X		X	
dsPIC33/PIC24EP256		X		X	X
dsPIC33/PIC24EP512			X		

8. Module: PTG

When using the strobe output Step commands ('`PTGCTRL 0b1110`', '`PTGCTRL 0b1100`' and '`PTGCTRL 0b1101`') to write to the `AD1CHS0` register, the `PTGPWD[3:0]` bits (`PTGCON[7:4]`) determine the number of times the PTG module will write to the `AD1CHS0` register.

Work around

Set the `PTGPWD[3:0]` bits to '0000' so that the PTG module does not write to the `AD1CHS0` register multiple times.

Affected Families and Silicon Revisions

Device	A2	A3	A7	A8	A9
dsPIC33/PIC24EP32		X		X	
dsPIC33/PIC24EP64	X	X		X	
dsPIC33/PIC24EP128		X		X	
dsPIC33/PIC24EP256		X		X	X
dsPIC33/PIC24EP512			X		

9. Module: Op Amp

When using any of these op amp modules or analog channels, AN0, AN3 or AN6, to sample external signals, bit 11 of the CMxCON register must be set to '1'.

If Using This Feature:	These Conditions Must be Met:	
	OPMODE (CMxCON[10])	CMxCON[11]
AN0	OPMODE (CM2CON[10]) = 0	CM2CON[11] = 1
AN3	OPMODE (CM1CON[10]) = 0	CM1CON[11] = 1
AN6	OPMODE (CM3CON[10]) = 0	CM3CON[11] = 1
Op Amp 1	OPMODE (CM1CON[10]) = 1	CM1CON[11] = 1
Op Amp 2	OPMODE (CM2CON[10]) = 1	CM2CON[11] = 1
Op Amp 3	OPMODE (CM3CON[10]) = 1	CM3CON[11] = 1

Work around

None.

Affected Families and Silicon Revisions

Device	A2	A3	A7	A8	A9
dsPIC33/PIC24EP32					
dsPIC33/PIC24EP64	X				
dsPIC33/PIC24EP128					
dsPIC33/PIC24EP256					
dsPIC33/PIC24EP512					

10. Module: Op Amp

The AC/DC electrical characteristics for the op amp module (and the related ADC module specifications) differ from the specifications in the published data sheet. Refer to [Table 3](#) and [Table 4](#) (below) for the A2 revision silicon specifications.

Work around

None.

Affected Families and Silicon Revisions

Device	A2	A3	A7	A8	A9
dsPIC33/PIC24EP32					
dsPIC33/PIC24EP64	X				
dsPIC33/PIC24EP128					
dsPIC33/PIC24EP256					
dsPIC33/PIC24EP512					

TABLE 3: AC/DC CHARACTERISTICS: OP AMP

Param. No.	Symbol	Minimum	Typical	Maximum	Units	Conditions
CM21a	PM	—	40	—	Degree	—
CM21b	PM	—	30	—	Degree	—
CM23a	GBW	—	7	—	MHz	—
CM23b	GBW	—	2	—	MHz	—
CM49a	VOADC	AVSS + 0.350	—	AVDD – 0.350	V	IOUT = 390 µA, Op Amps 1 and 2 IOUT = 390 µA, Op Amp 3
		AVSS + 0.500	—	AVDD – 0.500	V	
CM49b	VOUT	AVSS + 0.375	—	AVDD – 0.375	V	IOUT = 390 µA, Op Amps 1 and 2 IOUT = 390 µA, Op Amp 3
		AVSS + 0.525	—	AVDD – 0.525	V	
CM51a	RINT1	351	468	613	Ω	—

TABLE 4: AC/DC CHARACTERISTICS: ADC

Parameter No.	Symbol	Minimum	Typical	Maximum	Units	Conditions
AD57b	TSAMP	5 TAD	—	—	—	Op Amps 1 and 2, 12-bit mode, Configuration B
		5 TAD	—	—	—	Op Amp 3, 10-bit mode, Configuration B
		7 TAD	—	—	—	Op Amp 3, 12-bit mode, Configuration B

11. Module: PWM

When dead-time compensation is enabled (DTC[1:0] (PWMCONx[7:6]) = 11) in Center-Aligned mode (CAM (PWMCONx[2]) = 1), the dead time, as specified in the ALTDTRx register, is not being applied to the PWMxH output. The leading and trailing edges of the PWMxL output are extended by one-half the value of the ALTDTRx register, but the PWMxH leading and trailing edges are unaffected.

Work around

Using the values from “High-Speed PWM” (DS70645) in the “dsPIC33/PIC24 Family Reference Manual”, adjust the PWM parameters as follows:

- Subtract one-half of the ALTDTR dead time from PDCx
- Use twice the value for ALTDTR. For example:
 - Frequency of 60 kHz, duty cycle of 50%
 - Desired dead time of 833 ns and dead-time compensation of 833 ns

Using the specified values from “High-Speed PWM” (DS70645):

- PHASEx = 1000
- PDCx = 500
- ALTDTRx = 833 ns/8.33 ns = 100
- DTRx = (833 ns/8.33 ns)/2 = 50

Applying the work around:

- ALTDTRx = 2 * 100 = 200
- PDCx = PDCx – 25 = 475

Affected Families and Silicon Revisions

Device	A2	A3	A7	A8	A9
dsPIC33/PIC24EP32		X		X	
dsPIC33/PIC24EP64	X	X		X	
dsPIC33/PIC24EP128		X		X	
dsPIC33/PIC24EP256		X		X	X
dsPIC33/PIC24EP512			X		

12. Module: Flash

The processor stalls while performing Run-Time Self-Programming (RTSP) erase and write operations on the same Flash segment (General or Auxiliary) from which code is being executed. The Stall mechanism does not always function properly and can cause unexpected behavior.

Work around

Two options are available to avoid this issue:

1. If you are required to execute code, including an Interrupt Service Routine (ISR), from the same segment (either General or Auxiliary) that you are performing RTSP operations on, you must disable global interrupts until the erase or programming operation is complete (see [Example 1](#)).
2. If possible, structure your project such that RTSP operations are performed on a segment from which no code is being executed. For example, place all of your executable code in the General Segment and all reprogrammable data in the Auxiliary Segment, or vice versa. This solution has the added advantage that no CPU Stalls occur since the programming operation is not being performed on the same segment that is executing the code.

EXAMPLE 1: WORK AROUND CODE

```

; Load write latches if programming ...
; Setup NVMCON register to erase or program
as required ...
; Disable interrupts
PUSH W0
PUSH W1
MOV INTCON2, W1
BCLR INTCON2, #15
; Write the KEY sequence
MOV #0x55, W0
MOV W0, NVMKEY
MOV #0xAA, W0
MOV W0, NVMKEY
; Start the programming sequence
BSET NVMCON, #15
; Insert two NOPs after programming
NOP
NOP
; Wait for operation to complete
prog_wait:
BTSC NVMCON, #15
BRA prog_wait
; Re-enable interrupts,
BTSC W1, #15
BSET INTCON2, #15
POP W1
POP W0
    
```

Affected Families and Silicon Revisions

Device	A2	A3	A7	A8	A9
dsPIC33/PIC24EP32					
dsPIC33/PIC24EP64	X	X		X	
dsPIC33/PIC24EP128					
dsPIC33/PIC24EP256					
dsPIC33/PIC24EP512					

13. Module: QEI

In Quadrature Encoder mode (CCM[1:0] (QEIXCON[1:0]) = 00), the Index Counter registers (INDXxCNTH and INDXxCNTL) cannot be relied upon to increment when the last known direction was positive and an index pulse occurs. The Index Counter register can decrement even if the last known direction was positive. This does not apply to the External Clock or Internal Timer QEI modes.

Work around

The index event can be used to implement a software counter. The direction could be determined by comparing the current POSxCNT value to that of the previous Index Event.

Affected Families and Silicon Revisions

Device	A2	A3	A7	A8	A9
dsPIC33/PIC24EP32		X		X	
dsPIC33/PIC24EP64	X	X		X	
dsPIC33/PIC24EP128		X		X	
dsPIC33/PIC24EP256		X		X	X
dsPIC33/PIC24EP512			X		

14. Module: QEI

When Modulo Count mode (Mode 6) is selected for the position counter (PIMOD[2:0] (QEIXCON[12:10]) = 110), and the counter direction is set to negative (CNTPOL (QEIXCON[3]) = 1), the functions of the QEIXLEC and QEIXGEC registers are reversed.

Work around

When using Modulo Count mode in conjunction with a negative count direction (polarity), use the QEIXLEC register as the upper count limit and the QEIXGEC as the lower count limit.

Affected Families and Silicon Revisions

Device	A2	A3	A7	A8	A9
dsPIC33/PIC24EP32		X		X	
dsPIC33/PIC24EP64	X	X		X	
dsPIC33/PIC24EP128		X		X	
dsPIC33/PIC24EP256		X		X	X
dsPIC33/PIC24EP512			X		

15. Module: PWM

The PWMx module can operate with variable period, duty cycle, dead-time and phase values. The master period and other timing parameters can be updated in the same PWM cycle. With immediate updates disabled, the new values should take effect at the start of the next PWM cycle.

As a result of this issue, the updated master period takes effect on the next PWM cycle, while the update of the additional timing parameter is delayed by one PWM cycle. The parameters affected by this erratum are as follows:

Master Period Registers – Update effective on the next PWM cycle (PTPER).

Additional PWM Timing Parameters – Update effective one PWM cycle after master period update:

- Duty Cycle – PDCx and MDC registers
- Phase – PHASEx register
- Dead Time – DTRx and ALTDTRx registers and dead-time compensation signals
- Clearing of current-limit and Fault conditions, and application of External Period Reset signal

Work around

If the application requires the master period and other parameters to be updated at the same time, enable both immediate updates:

- EIPU (PTCON[10]) = 1 – To enable immediate period updates
- IUE (PWMCONx[0]) = 1 – To enable immediate updates of additional parameters listed above

Enabling immediate updates will allow updates to the master period and the other parameter to take effect immediately after writing to the respective registers.

Affected Families and Silicon Revisions

Device	A2	A3	A7	A8	A9
dsPIC33/PIC24EP32		X		X	
dsPIC33/PIC24EP64	X	X		X	
dsPIC33/PIC24EP128		X		X	
dsPIC33/PIC24EP256		X		X	X
dsPIC33/PIC24EP512			X		

16. Module: ADC

Selecting the same ANx input (AN0 or AN3) for CH0 and CH1 to achieve a 1.1 Msps sampling rate results in erroneous readings for CH1.

Work around

Bring the analog signal into the device using both AN0 and AN3, connect externally, and then assign one input to CH0 and the other to CH1.

If selecting AN0 on CH1 (CH123Sx = 0), select AN3 on CH0 (CH0Sx = 3). Conversely, if selecting AN3 on CH1 (CH123Sx = 1), select AN0 on CH0 (CH0Sx = 0).

Affected Families and Silicon Revisions

Device	A2	A3	A7	A8	A9
dsPIC33/PIC24EP32		X		X	
dsPIC33/PIC24EP64	X	X		X	
dsPIC33/PIC24EP128		X		X	
dsPIC33/PIC24EP256		X		X	X
dsPIC33/PIC24EP512			X		

17. Module: ADC

Selection of channels for channel scan operation is limited to those available in the AD1CSSL register (AN0 through AN15). Selections in the AD1CSSH register, (OA1 through OA3, CTMU TEMP and CTMU Open) are not available.

Work around

There is no work around of the CTMU TEMP and CTMU Open selections. OA1 through OA3 can be scanned using AN3, AN0 and AN6 for Op Amp 1, Op Amp 2 and Op Amp 3, respectively.

Affected Families and Silicon Revisions

Device	A2	A3	A7	A8	A9
dsPIC33/PIC24EP32		X		X	
dsPIC33/PIC24EP64	X	X		X	
dsPIC33/PIC24EP128		X		X	
dsPIC33/PIC24EP256		X		X	X
dsPIC33/PIC24EP512			X		

18. Module: Output Compare

Under certain circumstances, an output compare match may cause the Output Compare Interrupt Flag (OCxIF) to become set prior to the Change-of-State (COS) of the OCx pin. This has been observed when all of the following are true:

- The module is in One-Shot mode (OCM[2:0] = 001, 010 or 100);
- One of the timer modules is being used as the time base; and
- A timer prescaler other than 1:1 is selected

If the module is re-initialized by clearing OCM[2:0] after the One-Shot compare, the OCx pin may not be driven as expected.

Work around

After OCxIF is set, allow an interval (in CPU cycles) of at least twice the prescaler factor to elapse before clearing OCM[2:0]. For example, for a prescaler value of 1:8, allow 16 CPU cycles to elapse after the interrupt.

Affected Families and Silicon Revisions

Device	A2	A3	A7	A8	A9
dsPIC33/PIC24EP32		X		X	
dsPIC33/PIC24EP64	X	X		X	
dsPIC33/PIC24EP128		X		X	
dsPIC33/PIC24EP256		X		X	X
dsPIC33/PIC24EP512			X		

19. Module: CAN

When DMA is used with the CAN module, and the CPU and DMA write to an CAN Special Function Register (SFR) at the same time, the DMAC error trap is not occurring. In addition, neither the PWCOL[3:0] bits of the DMAPWC SFR or the DMACERR bit of the INTCON1 SFR are being set. Since the PWCOLx bits are not set, subsequent DMA requests to that channel are not ignored.

Work around

There is no work around; however, under normal circumstances, this situation should not arise. When DMA is used with the CAN module, the application should not be writing to the CAN SFRs.

Affected Families and Silicon Revisions

Device	A2	A3	A7	A8	A9
dsPIC33/PIC24EP32		X		X	
dsPIC33/PIC24EP64	X	X		X	
dsPIC33/PIC24EP128		X		X	
dsPIC33/PIC24EP256		X		X	X
dsPIC33/PIC24EP512			X		

20. Module: PWM

The PWM generator may not assert dead time on the edges of transitions. This has been observed when all of the following conditions are present:

- The PWM generator is configured to operate in Complementary mode with Independent Time Base (ITB) or master time base;
- Immediate update is enabled; and
- The value in the PDC register is updated in such a manner that the PWMxH and PWMxL outputs make an immediate transition.

The current duty cycle, PDC_{OLD}, newly calculated duty cycle, PDC_{NEW}, and the point at which a write to the Duty Cycle register occurs within the PWM

time base, will determine if the PWMxH and PWMxL outputs make an immediate transition. PWMxH and PWMxL outputs make an immediate transition if the Duty Cycle register is written with a new value, PDC_{NEW}, at a point of time when the PWM time base is counting a value that is between PDC_{NEW} and PDC_{OLD}. Additionally, writing to the Duty Cycle register, close to the instant of time where dead time is being applied, may result in a reduced dead time effective on the PWMxH and PWMxL transition edges.

In Figure 1, if the duty cycle write occurred in the shaded box, then PWMxH and PWMxL will make an immediate transition without dead time.

FIGURE 1: TIMING DIAGRAMS FOR CENTER-ALIGNED AND EDGE-ALIGNED MODES

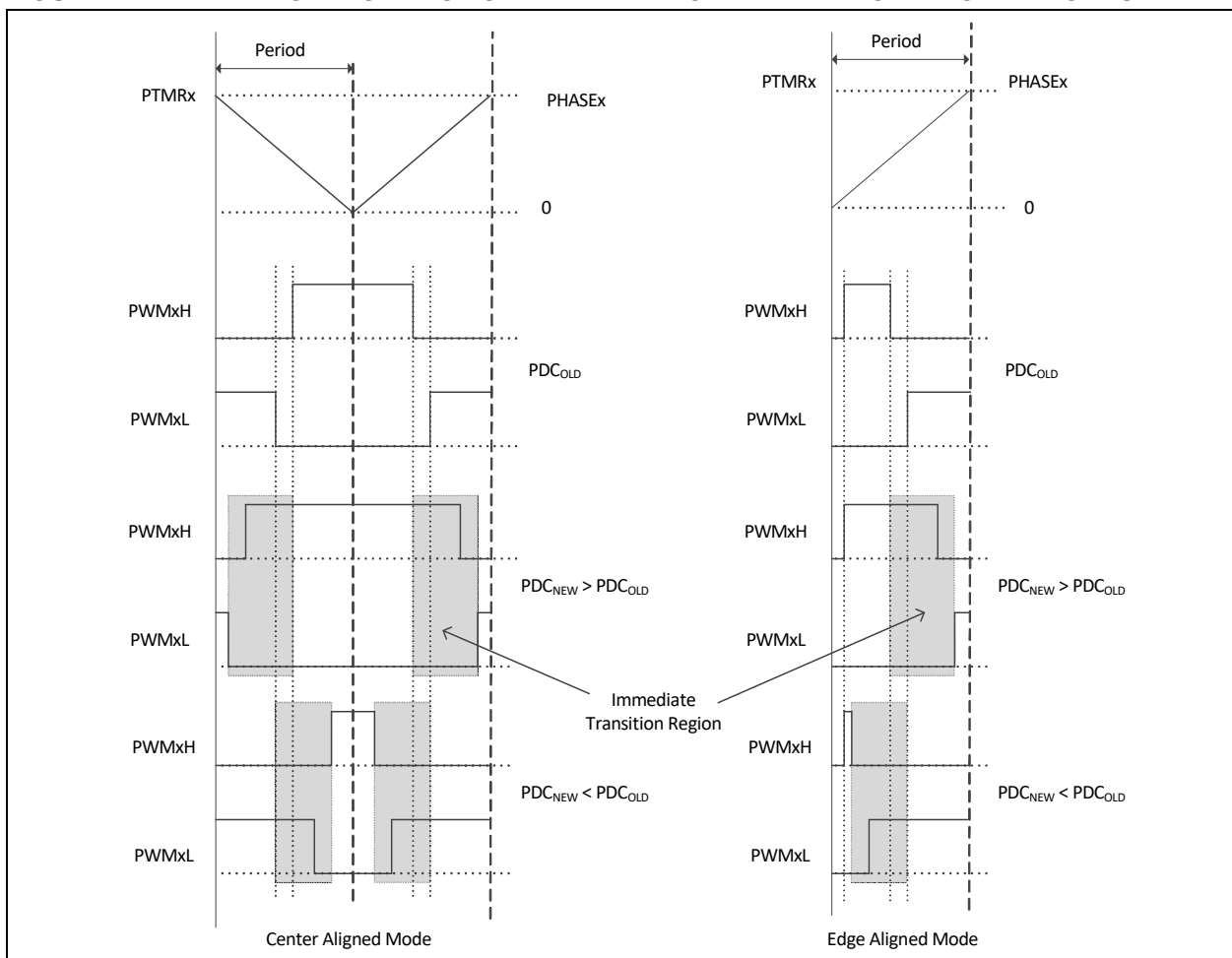

Work around

None.

However, in most applications the duty cycle update timing can be controlled using the TRIGx trigger, or Special Event Trigger, such that the above mentioned conditions are avoided altogether.

Affected Families and Silicon Revisions

Device	A2	A3	A7	A8	A9
dsPIC33/PIC24EP32		X		X	
dsPIC33/PIC24EP64	X	X		X	
dsPIC33/PIC24EP128		X		X	
dsPIC33/PIC24EP256		X		X	X
dsPIC33/PIC24EP512			X		

21. Module: PWM

In Center-Aligned Complementary mode with Independent Time Base, the PWM generator may assert the PWMxH output for 100% of the duty cycle. This has been observed when the value in its PDCx register is less than one-half the value in its ALTDTRx register.

Work around

Include a software routine to check that the duty cycle value written to the PDCx register is always at least one-half of the value in ALTDTRx.

Example 2 shows one way of doing this, with PDCtemp representing the value to be written to the PDCx register.

EXAMPLE 2: WORK AROUND CODE

```

Altdtr_by2 = ALTDTRx / 2;
if (PDCtemp < Altdtr_by2)
{
    PDCx = Altdtr_by2;
}
else
{
    PDCx = PDCtemp;
}
    
```

Affected Families and Silicon Revisions

Device	A2	A3	A7	A8	A9
dsPIC33/PIC24EP32		X			
dsPIC33/PIC24EP64	X	X			
dsPIC33/PIC24EP128		X			
dsPIC33/PIC24EP256		X			
dsPIC33/PIC24EP512					

22. Module: PWM

This issue is applicable when a PWM generator is configured to operate in Independent Time Base mode with either Center-Aligned Complementary mode or Edge-Aligned Complementary mode. When dead time is non-zero, PWMxL is not asserted for 100% of the time when PDCx is zero. Similarly, when dead time is non-zero, PWMxH is not asserted for 100% of the time when PDCx is equal to PHASEx. This issue applies to Master Time Base mode as well.

Work around

In Center-Aligned mode:

- To obtain 0% duty cycle, first zero out the ALTDTRx register, then write zero to the PDCx register.
- To obtain 100% duty cycle, first zero out the ALTDTRx register, then write (PHASEx + 2) to the PDCx register.

In Edge-Aligned mode:

- To obtain 0% duty cycle, first zero out the registers, DTRx and ALTDTRx, then write zero to the PDCx register.
- To obtain 100% duty cycle, first zero out the registers, DTRx and ALTDTRx, then write (PHASEx + 1) to the PDCx register.

Alternatively, in both Center-Aligned and Edge-Aligned PWM modes, 0% and 100% duty cycle can be obtained by enabling the PWM override (IOCONx[9:8] = 0b11) with the Output Override Synchronization bit (IOCONx[0]) set as '1':

- For 0% duty cycle, set the Override Data bits (IOCONx[7:6]) for PWMxH and PWMxL as '0b01'
- For 100% duty cycle, set the Override Data bits (IOCONx[7:6]) for PWMxH and PWMxL as '0b10'

Affected Families and Silicon Revisions

Device	A2	A3	A7	A8	A9
dsPIC33/PIC24EP32		X		X	
dsPIC33/PIC24EP64	X	X		X	
dsPIC33/PIC24EP128		X		X	
dsPIC33/PIC24EP256		X		X	X
dsPIC33/PIC24EP512			X		

23. Module: CPU

An unexpected address error trap may occur during accesses to program memory addresses, 0x001 through 0x200. This has been observed when one or more interrupt requests are asserted while reading or writing program memory addresses, using TBLRDx, TBLWTx or PSV-based instructions.

Work around

Before executing instructions that read or write program memory addresses, 0x001 through 0x200, disable interrupts using the DISI instruction.

Affected Families and Silicon Revisions

Device	A2	A3	A7	A8	A9
dsPIC33/PIC24EP32		X		X	
dsPIC33/PIC24EP64	X	X		X	
dsPIC33/PIC24EP128		X		X	
dsPIC33/PIC24EP256		X		X	X
dsPIC33/PIC24EP512			X		

24. Module: PWM

In Center-Aligned mode, updates to active MDC/PDCx/ALTDTRx/PHASEx registers occur only once every two PWM periods; that is, when the PWM timer matches the PHASEx register. In other words, the double update feature is not available. Figure 2 illustrates this relationship.

Work around

None.

Affected Families and Silicon Revisions

Device	A2	A3	A7	A8	A9
dsPIC33/PIC24EP32		X			
dsPIC33/PIC24EP64	X	X			
dsPIC33/PIC24EP128		X			
dsPIC33/PIC24EP256		X			
dsPIC33/PIC24EP512					

FIGURE 2: PWM TIMING DIAGRAM

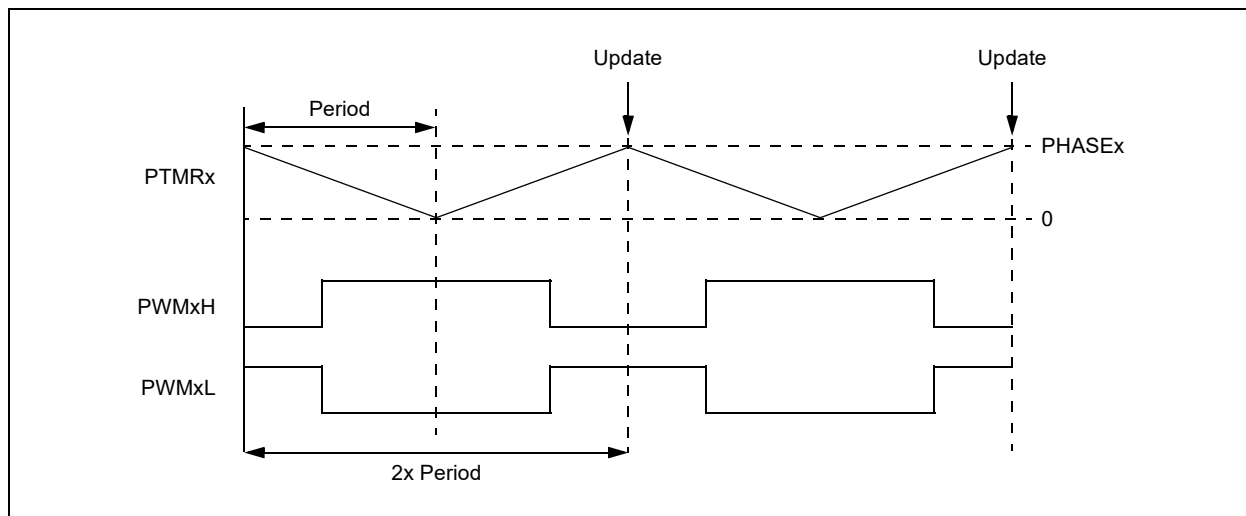

25. Module: PWM

Under certain circumstances, an update to the IOCONx register to turn off the override will be ignored by the PWMx module. The issue has been observed to occur when the IOCONx update to turn off the override occurs close to the time when dead time is being applied.

Work around

1. Turn off the PWM dead time.
2. Alternatively, turn off the PWM override with the following procedure:
 - a) Disable the PWMx module (PTEN = 0)
 - b) Clear the Override Enable bits (OVRENH = 0 and OVRENL = 0)
 - c) Enable the PWMx module (PTEN = 1)

Affected Families and Silicon Revisions

Device	A2	A3	A7	A8	A9
dsPIC33/PIC24EP32		X			
dsPIC33/PIC24EP64	X	X			
dsPIC33/PIC24EP128		X			
dsPIC33/PIC24EP256		X			
dsPIC33/PIC24EP512	See Silicon Issue 40 .				

26. Module: PWM

In Center-Aligned Complementary mode with Independent Time Base, updates to the PHASEx register take effect after a delay of two PWM periods.

This occurs only when the Immediate Update feature is disabled (IUE = 0). If Immediate Update is enabled (IUE = 1), the PHASEx register updates will take effect immediately.

Work around

None.

Affected Families and Silicon Revisions

Device	A2	A3	A7	A8	A9
dsPIC33/PIC24EP32		X			
dsPIC33/PIC24EP64	X	X			
dsPIC33/PIC24EP128		X			
dsPIC33/PIC24EP256		X			
dsPIC33/PIC24EP512					

27. Module: CTMU

The CTMU cannot be used with the A/D Converter when the converter is operating in 12-bit mode.

Work around

None.

Affected Families and Silicon Revisions

Device	A2	A3	A7	A8	A9
dsPIC33/PIC24EP32		X		X	
dsPIC33/PIC24EP64	X	X		X	
dsPIC33/PIC24EP128		X		X	
dsPIC33/PIC24EP256		X		X	X
dsPIC33/PIC24EP512			X		

28. Module: Input Capture

When an input capture module is selected as the Sync source for either an output compare module or another input capture module, synchronization may fail.

Work around

None.

Affected Families and Silicon Revisions

Device	A2	A3	A7	A8	A9
dsPIC33/PIC24EP32		X		X	
dsPIC33/PIC24EP64	X	X		X	
dsPIC33/PIC24EP128		X		X	
dsPIC33/PIC24EP256		X		X	X
dsPIC33/PIC24EP512			X		

29. Module: JTAG

This is no longer an issue to any silicon revisions and has been removed.

Work around

No work around necessary.

Affected Families and Silicon Revisions

Device	A2	A3	A7	A8	A9
dsPIC33/PIC24EP32					
dsPIC33/PIC24EP64					
dsPIC33/PIC24EP128					
dsPIC33/PIC24EP256					
dsPIC33/PIC24EP512					

30. Module: I/O

On all packages, pins with the following functions are not 5V tolerant:

- RC3
- RC4
- RC5
- RA9

Work around

None.

Affected Families and Silicon Revisions

Device	A2	A3	A7	A8	A9
dsPIC33/PIC24EP32		X			
dsPIC33/PIC24EP64	X	X			
dsPIC33/PIC24EP128		X			
dsPIC33/PIC24EP256		X			
dsPIC33/PIC24EP512					

31. Module: JTAG

At a Power-on Reset (POR), when JTAG is disabled in the Configuration bits, the I/O pin with TMS function produces an active-high logic pulse with a pulse width in the order of milliseconds.

Work around

None.

Affected Families and Silicon Revisions

Device	A2	A3	A7	A8	A9
dsPIC33/PIC24EP32		X			
dsPIC33/PIC24EP64	X	X			
dsPIC33/PIC24EP128		X			
dsPIC33/PIC24EP256		X			
dsPIC33/PIC24EP512					

32. Module: QEI

The Velocity Counter x (VELxCNT) register is a 16-bit wide register that increments or decrements based on the signal from the quadrature decoder logic. Reading this register results in a Counter Reset. Typically, the user application should read the Velocity Counter at a rate of 1-4 kHz.

As a result of this issue, the Velocity Counter may miss a count if the user application reads the Velocity Counter 1 register at the same time as a (+1 or -1) count increment occurs.

Work around

None.

Affected Families and Silicon Revisions

Device	A2	A3	A7	A8	A9
dsPIC33/PIC24EP32		X		X	
dsPIC33/PIC24EP64	X	X		X	
dsPIC33/PIC24EP128		X		X	
dsPIC33/PIC24EP256		X		X	X
dsPIC33/PIC24EP512			X		

33. Module: QEI

When index count position capture is being used (QEIXIOC.QCAPEN = 1), the position count may be one more or one less than the correct value, depending on the direction of the count.

This is only observed when the leading edge of the index pulse occurs prior to the leading edge of the index match event. When the index pulse starts after the leading edge of the index match event, the position count is captured correctly.

Figure 3 shows how this occurs. In these cases, Encoder Signals A, B and (index) Z are shown, with the module being configured for index match when A and B are '0'. The effects of a correct and incorrect capture are shown side by side (shaded area indicates the index match event); the position count is shown along the bottom.

FIGURE 3: CORRECT AND INCORRECT POSITION COUNT CAPTURES

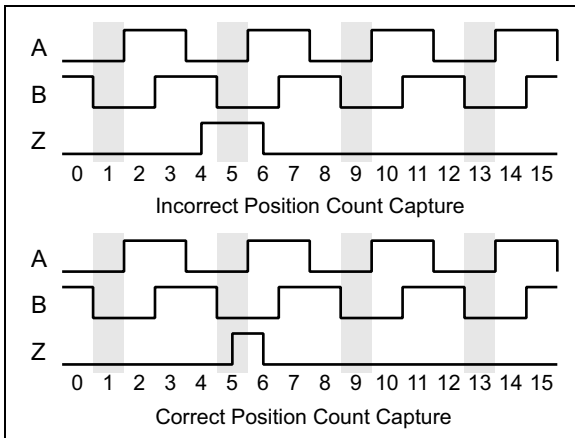

Work around

There are two different work arounds depending on the encoder type.

For encoder signals with timing that ensures the index pulse always starts prior to the start of the index match event (i.e., encoders with a non-gated index pulse), measure the direction of the encoder motion. If the encoder is counting up, add one to the captured position count; if the encoder is counting down, subtract one from the captured position count.

For encoder signals where the index pulse leading edge approximately coincides with the start of the index match event (i.e., encoders with a gated index pulse), a small delay can be added to the index pulse, for instance, by using a simple R-C filter.

If the encoder does not meet either of these criteria, no work around is available.

Affected Families and Silicon Revisions

Device	A2	A3	A7	A8	A9
dsPIC33/PIC24EP32					
dsPIC33/PIC24EP64					
dsPIC33/PIC24EP128					
dsPIC33/PIC24EP256					
dsPIC33/PIC24EP512			X		

34. Module: QEI

When QCAPEN (QEIXIOC[15]) is enabled, the position count is captured at the rising edge of the HOME signal, instead of the index match event as indicated by the data sheet.

Work around

None.

Affected Families and Silicon Revisions

Device	A2	A3	A7	A8	A9
dsPIC33/PIC24EP32		X			
dsPIC33/PIC24EP64	X	X			
dsPIC33/PIC24EP128		X			
dsPIC33/PIC24EP256		X			
dsPIC33/PIC24EP512					

35. Module: PWM

In Center-Aligned Complementary mode with Independent Time Base, if the value in the PDCx register is less than one-half the value in the ALTDTRx register, the PWM generator will force the PWMxL to low, and on the PWMxH, generate pulses of width less than twice the dead time, as shown in Figure 4.

FIGURE 4: PWM GENERATOR TIMING DIAGRAM

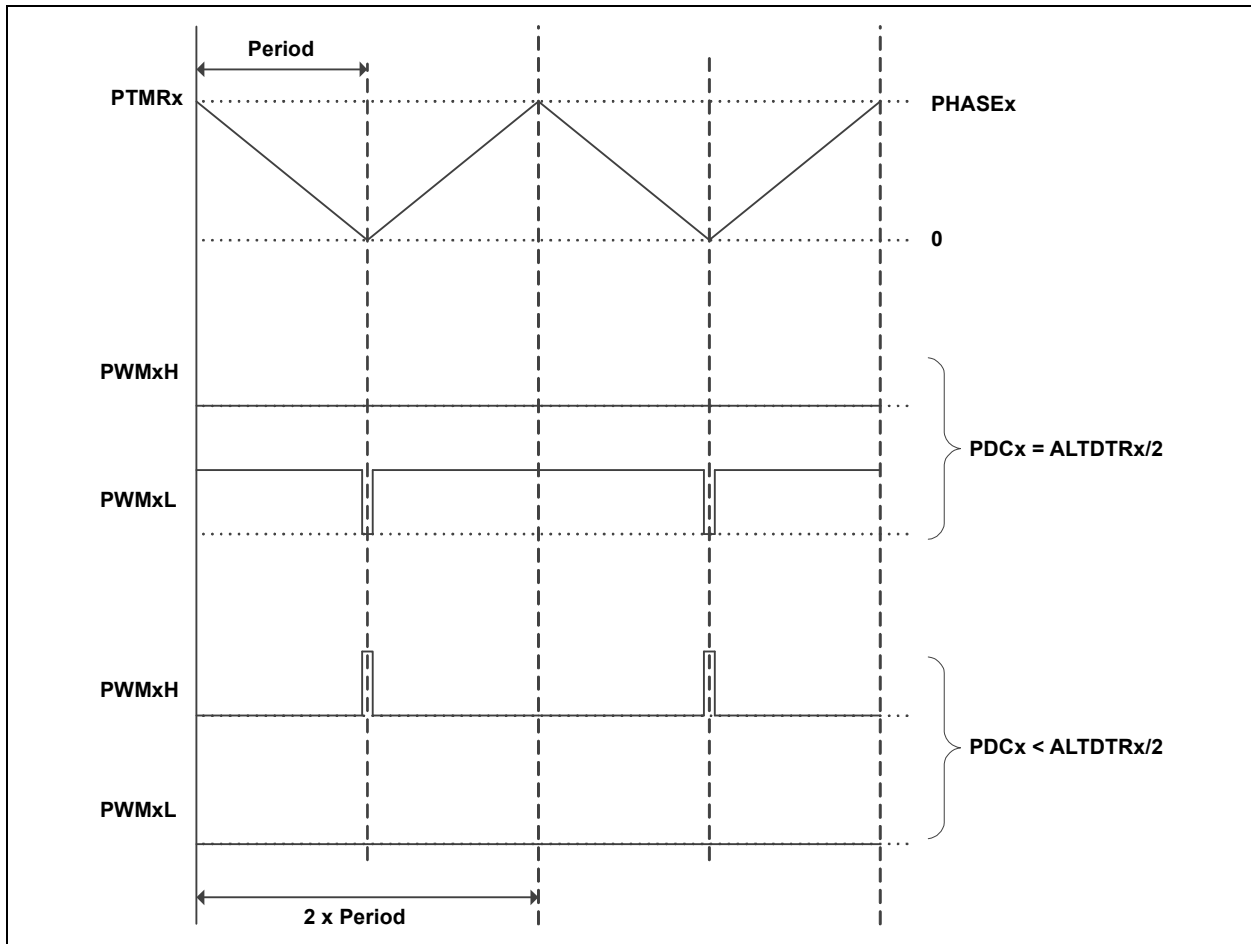

Work around

Include a software routine to ensure that the duty cycle value written to the PDCx register is always at least one-half of the value in ALTDTRx. [Example 3](#) shows one method, with PDCtemp representing the variable which has the value to be written to the PDCx register. Alternatively, for duty cycle values less than half the desired dead-time value, zero out the ALTDTRx register or dynamically reduce the value in the ALTDTRx register, such that ALTDTRx is always equal to 2 * PDCx, as shown in [Example 4](#).

EXAMPLE 3: WORK AROUND CODE

```
Altdtr_by2 = ALTDTRx / 2;
if (PDCtemp < Altdtr_by2)
{
PDCx = Altdtr_by2;
}
else
{
PDCx = PDCtemp;
}
```

EXAMPLE 4: WORK AROUND CODE

```
#define DESIRED_DEADTIME 100
if (PDCtemp < (DESIRED_DEADTIME/2))
{
ALTDTRx = PDCtemp * 2;
PDCx = PDCtemp;
}
else
{
ALTDTRx = DESIRED_DEADTIME;
PDCx = PDCtemp;
}
```

Affected Families and Silicon Revisions

Device	A2	A3	A7	A8	A9
dsPIC33/PIC24EP32				X	
dsPIC33/PIC24EP64				X	
dsPIC33/PIC24EP128				X	
dsPIC33/PIC24EP256				X	X
dsPIC33/PIC24EP512			X		

36. Module: PWM

When the PWM generator is configured to operate in Current Reset mode (XPRES (PWMCONx[1]) = 1 with Independent Time Base mode (ITB (PWMCONx[9]) = 1), the PWM Reset will happen only in every alternate PWM cycle.

Work around

1. Generate an interrupt when the comparator state changes. This interrupt should be high priority and could be either a comparator interrupt or PWM Fault interrupt. The current-limit interrupt does not function in this mode. Inside the interrupt, update PHASEx (period value) with a value less than the programmed duty cycle and then immediately update the PHASEx register with the value, as required by the application (PWM_period), shown in [Example 5](#).

EXAMPLE 5: WORK AROUND CODE

```
PWMx_ISR:
{
PHASEx = PDCx - 100;
PHASEx = PWM_period;
PWMxIF = 0;
}
```

2. When the External Current Reset signal is applied to the PWM generator (configured using Current-Limit Signal Source Select bits (CLSRC[4:0]) in the PWMx Fault Current-Limit Control registers (FCLCONx[14:10]), depending on the PWM resolution selected, PCLKDIV[2:0] (PTCON2[2:0]), the maximum pulse width of the External Current Reset signal is to be restricted to less than the values, as shown in [Table 5](#).

TABLE 5: MAXIMUM EXTERNAL CURRENT RESET SIGNAL WIDTH

PCLKDIV[2:0]	Max. External Current Reset Signal Width (in nS)
000	20
001	40
010	80
011	160
100	320
101	640
110	1280

Affected Families and Silicon Revisions

Device	A2	A3	A7	A8	A9
dsPIC33/PIC24EP32		X			
dsPIC33/PIC24EP64	X	X			
dsPIC33/PIC24EP128		X			
dsPIC33/PIC24EP256		X			
dsPIC33/PIC24EP512			X		

37. Module: Op Amp/Comparator

Op amp/comparator voltage reference can choose its source either from VREF+ or AVDD, depending on the CVRSS bit (CVRCON[4]) setting.

If the CVRSS bit is set to '1', the comparator voltage reference source will be CVRSRC = (VREF+) – (AVSS). Due to this issue, if the CVRSS bit is set to '1' and the voltage on VREF+ is less than 1.33V, the op amp/comparator voltage reference will malfunction.

Work around

None.

Affected Families and Silicon Revisions

Device	A2	A3	A7	A8	A9
dsPIC33/PIC24EP32		X		X	
dsPIC33/PIC24EP64	X	X		X	
dsPIC33/PIC24EP128		X		X	
dsPIC33/PIC24EP256		X		X	X
dsPIC33/PIC24EP512			X		

38. Module: PWM

In Complementary mode after the PWMx module is enabled (PTEN = 1), if the PWM override is turned off, a 1 T_{osc} glitch will be present on the rising edge of either PWMxH or PWMxL, whichever occurs first, as shown in Figure 5. The glitch will be present on PWMxH/PWMxL every time the override state is changed from enabled to disabled. The width of this glitch is equal to 1 T_{osc} when PCLKDIV[2:0] = 000; increasing the PWM input clock prescaler setting will increase the width of the glitch accordingly.

Since the width of the glitch is just 1 T_{osc} at higher values of F_{osc}, the glitch may not be visible on the PWMxH/PWMxL pins due to pin and PCB trace capacitances.

Work around

None.

Affected Families and Silicon Revisions

Device	A2	A3	A7	A8	A9
dsPIC33/PIC24EP32				X	
dsPIC33/PIC24EP64				X	
dsPIC33/PIC24EP128				X	
dsPIC33/PIC24EP256				X	X
dsPIC33/PIC24EP512					

FIGURE 5: ILLUSTRATION OF 1 T_{osc} GLITCH WHEN PWM OVERRIDE IS TURNED OFF

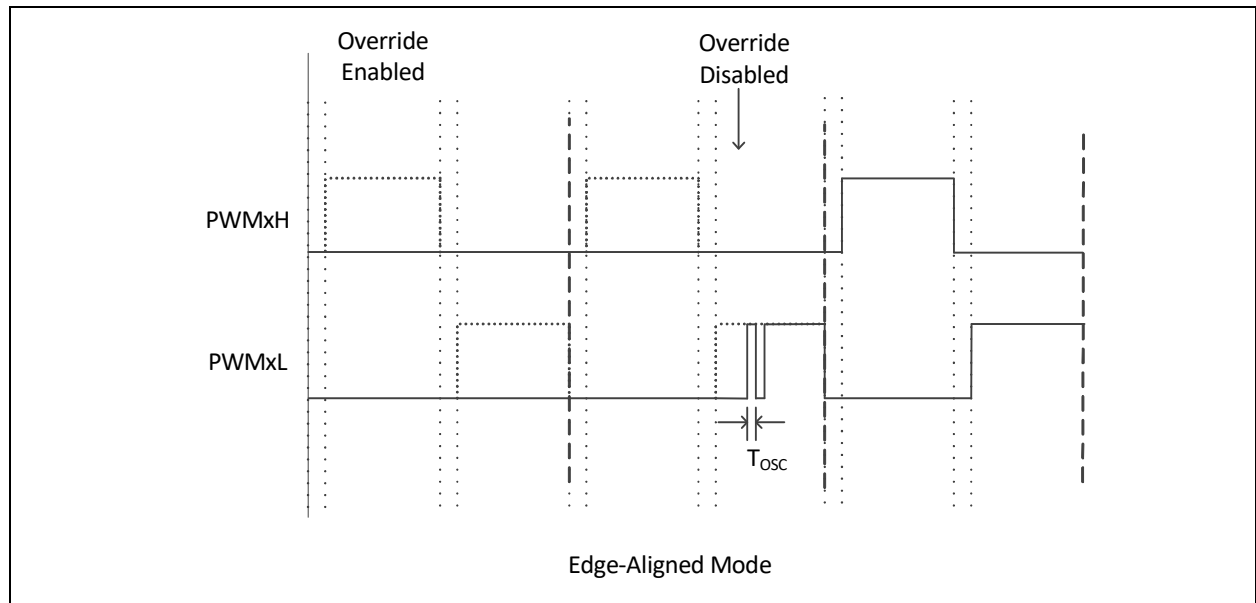

39. Module: PWM

In Complementary mode, if SWAP (IOCONx[1]) is set from '0' to '1' after enabling the PWMx module (PTEN (PTCON[15]) = 1), either PWMxH or PWMxL may stop functioning until SWAP is set back to '0'.

Work around

Disable dead time.

Affected Families and Silicon Revisions

Device	A2	A3	A7	A8	A9
dsPIC33/PIC24EP32		X			
dsPIC33/PIC24EP64	X	X			
dsPIC33/PIC24EP128		X			
dsPIC33/PIC24EP256		X			
dsPIC33/PIC24EP512			X		

40. Module: PWM

PWM override feature is not functional.

Work around

None.

Affected Families and Silicon Revisions

Device	A2	A3	A7	A8	A9
dsPIC33/PIC24EP32					
dsPIC33/PIC24EP64					
dsPIC33/PIC24EP128					
dsPIC33/PIC24EP256					
dsPIC33/PIC24EP512			X		

41. Module: CAN

When the DMA controller is copying the received CAN message into an appropriate message buffer in the user-defined device RAM area, any Read-Modify-Write operation on a CxRXFULx (C1RXFUL1, C1RXFUL2, C2RXFUL1 and C2RXFUL2) register may not update the CxRXFULx register properly. The CPU can only clear a bit in the CxRXFULx register. A Read-Modify-Write operation successfully clears the intended bit, but it may incorrectly clear the bit set by the CAN module after a successful transfer of a message into RAM by the DMA.

Work around

Avoid Read-Modify-Write operations on C1RXFUL1, C1RXFUL2, C2RXFUL1 and C2RXFUL2 registers. See [Example 6](#) to clear any bit in the C1RXFUL1, C1RXFUL2, C2RXFUL1 and C2RXFUL2 registers while developing code in C:

EXAMPLE 6: WORK AROUND CODE

```

if (C1FIFObits.FNRB <= 15)
{
    C1RXFUL1 = ~(0x001 << C1FIFObits.FNRB);
}
else
{
    C1RXFUL2 = ~(0x001 << (C1FIFObits.FNRB - 16));
}
    
```

The CPU can only clear a bit in the CxRXFULx registers, but the CPU cannot set any bit in any of the CxRXFULx registers. Therefore, in the work around ([Example 6](#)):

- If the FNRB[5:0] (C1FIFO[5:0]) bits value is less than or equal to 15, only one bit of the C1RXFUL1 register will be cleared depending on the FNRB[5:0] bits value.
- If the FNRB[5:0] bits value is greater than 15, only one bit of the C1RXFUL2 register will be cleared depending on the FNRB[5:0] bits value.

This same method should be adopted for the C2RXFUL1 and C2RXFUL2 registers.

Affected Families and Silicon Revisions

Device	A2	A3	A7	A8	A9
dsPIC33/PIC24EP32		X		X	
dsPIC33/PIC24EP64	X	X		X	
dsPIC33/PIC24EP128		X		X	
dsPIC33/PIC24EP256		X		X	X
dsPIC33/PIC24EP512			X		

42. Module: PWM

In Edge-Aligned Complementary mode, changes to the PHASEx register under certain circumstances will result in missing dead time at the PWMxH-to-PWMxL transition. This has been observed only when all of the following are true:

- Master Time Base mode is enabled (PWMCONx[9] = 0);
- PHASEx is changed after the PWMx module is enabled; and
- The PHASEx register value is changed, so that either PHASEx < DTRx or PHASEx > PDCx.

Work around

None.

Affected Families and Silicon Revisions

Device	A2	A3	A7	A8	A9
dsPIC33/PIC24EP32		X		X	
dsPIC33/PIC24EP64	X	X		X	
dsPIC33/PIC24EP128		X		X	
dsPIC33/PIC24EP256		X		X	X
dsPIC33/PIC24EP512			X		

43. Module: PWM

In certain output modes, the PWMx module produces a pulse glitch of one PWM clock in width (Figure 6). This has been observed only when all of the following are true:

- Either Redundant or Push-Pull Output mode is selected (IOCONx[11:10] = 10 or 01);
- Immediate Update is disabled (PWMCONx[0] = 0); and
- The value of the current Duty Cycle register (either the PDCx or MDC register, as determined by PWMCONx[8]) is updated to zero from any non-zero value.

The pulse glitch has been observed to occur at the beginning of the following PWM boundary period.

FIGURE 6:

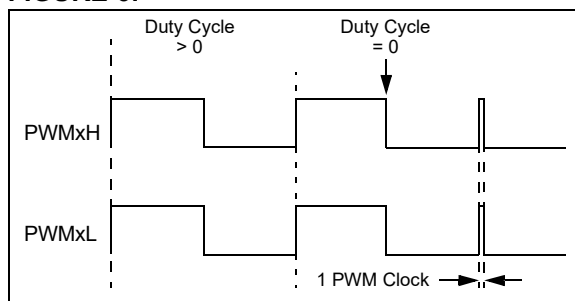

Work around

If the application requires a duty cycle of zero, two possible work arounds are available.

1. Use the PWM overrides to force the output to a low state, instead of writing a '0' to the Duty Cycle register. When using this method, the PWM override must be disabled when the duty cycle is a non-zero value. If output override synchronization is configured to occur on CPU clock boundaries (IOCONx[0] = 0), enabling and disabling the override must be timed to occur as closely as possible to the PWM period boundary.
2. Configure the module for Immediate Update (PWMCONx[0] = 1) before enabling the module. In this mode, writes to the Duty Cycle register have an immediate effect on the output. As with the previous work around, writes to the Duty Cycle register must be timed to occur as close to the PWM period boundary as possible in order to avoid distortion of the output.

Affected Families and Silicon Revisions

Device	A2	A3	A7	A8	A9
dsPIC33/PIC24EP32		X		X	
dsPIC33/PIC24EP64	X	X		X	
dsPIC33/PIC24EP128		X		X	
dsPIC33/PIC24EP256		X		X	X
dsPIC33/PIC24EP512			X		

44. Module: PWM

In Complementary Output mode, the expected dead time between transitions of the PWMxH and PWMxL outputs may not be asserted when the following occurs:

- Output override synchronization is configured to occur on the CPU clock boundary (IOCONx[0] = 0);
- Both PWMxH and PWMxL overrides are enabled prior to the event (OVRENH and OVRENL are both '1'), and
- Both overrides are disabled (OVRENH and OVRENL are both '0') at the instant the dead time should be asserted (Figure 7).

This has been observed in both Center-Aligned and Edge-Aligned modes.

FIGURE 7:

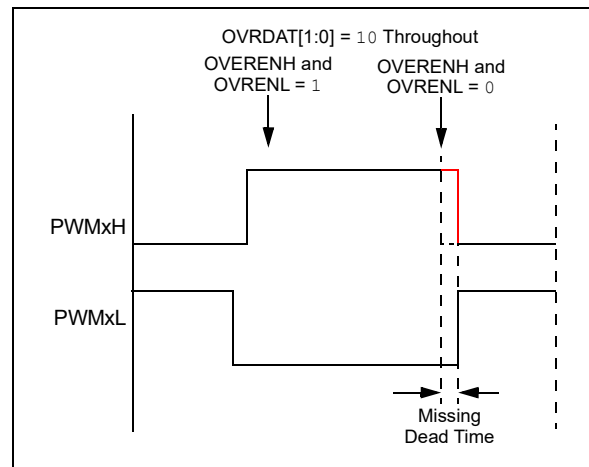

Work around

None.

Affected Families and Silicon Revisions

Device	A2	A3	A7	A8	A9
dsPIC33/PIC24EP32		X		X	
dsPIC33/PIC24EP64	X	X		X	
dsPIC33/PIC24EP128		X		X	
dsPIC33/PIC24EP256		X		X	X
dsPIC33/PIC24EP512			X		

45. Module: PWM

In Center-Aligned Complementary mode with Independent Time Base, the expected dead time between transitions of the PWMxH and PWMxL outputs may not be asserted when SWAP is disabled under the following conditions:

- PWMx module is enabled (PTEN = 1)
- SWAP is enabled prior to this event

Work around

None.

Affected Families and Silicon Revisions

Device	A2	A3	A7	A8	A9
dsPIC33/PIC24EP32		X		X	
dsPIC33/PIC24EP64	X	X		X	
dsPIC33/PIC24EP128		X		X	
dsPIC33/PIC24EP256		X		X	X
dsPIC33/PIC24EP512			X		

46. Module: PWM

In Center-Aligned Complementary mode with Independent Time Base, updates to the PHASEx register take effect in the middle of a center-aligned PWM cycle, as shown in Figure 8. This occurs only when the Immediate Update feature is disabled (IUE = 0). If Immediate Update is enabled (IUE = 1), the PHASEx register updates will take effect immediately.

Work around

None.

Affected Families and Silicon Revisions

Device	A2	A3	A7	A8	A9
dsPIC33/PIC24EP32				X	
dsPIC33/PIC24EP64				X	
dsPIC33/PIC24EP128				X	
dsPIC33/PIC24EP256				X	X
dsPIC33/PIC24EP512			X		

FIGURE 8:

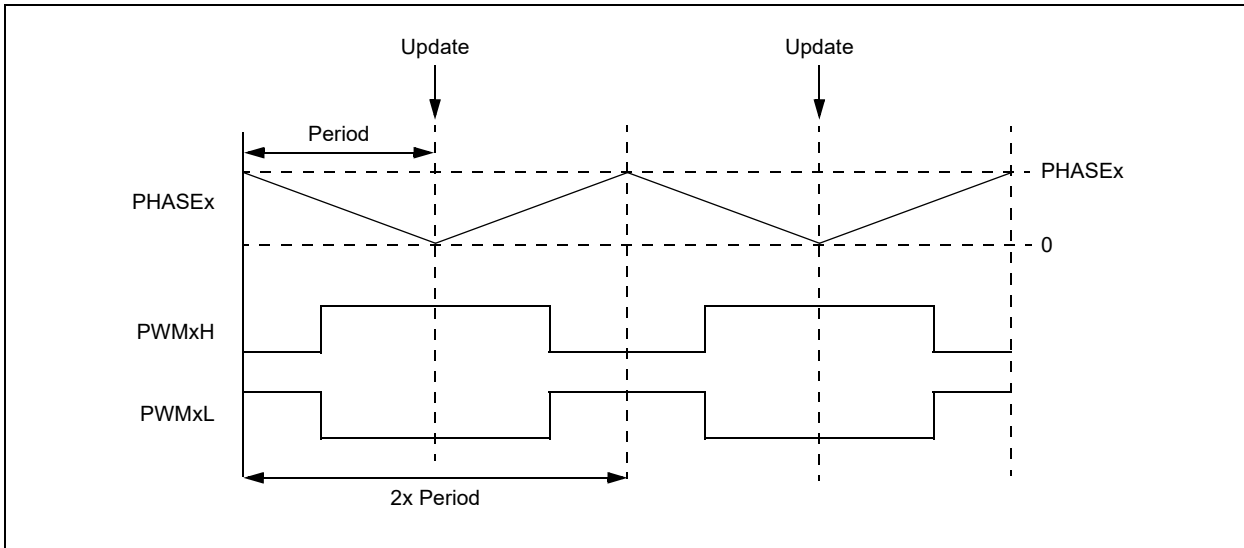

47. Module: CPU

Note: This issue is deterministic based on the instruction sequence executed, and is not sensitive to manufacturing process, temperature, voltage or other application operating conditions that do not affect the instruction sequence.

When two or more data Flash read instructions (via Program Space Visibility (PSV) read or table read) are executed back-to-back, one or more subsequent instructions can be misexecuted when all of the conditions in Table 6 occur.

TABLE 6: REQUIRED CONDITIONS

1.	A PSV <code>MOV.D</code> instruction is executed, with opcode at address ending in 0x0, 0x4, 0x8 or 0xC; and
2.	Some “connecting code” is executed (following the <code>MOV.D</code> of condition 1), with the properties: <ul style="list-style-type: none"> a) The connecting code does not include any program flow changes, including: taken branch instructions (including all versions of <code>BRA</code>, <code>CPBEQ</code>, <code>CPBGT</code>, <code>CPBLT</code>, <code>CPBNE</code>), <code>CALL</code>, <code>CALL.L</code>, <code>GOTO</code>, <code>GOTO.L</code>, <code>RCALL</code>, <code>RETLW</code>, <code>RETURN</code>, vectoring to an ISR, returning from an interrupt (<code>RETFIE</code>) and certain debug operations, such as <code>break</code> and <code>one-step</code>; and b) The connecting code does not include a <code>TBLRDx</code> or non-<code>MOV.D</code> PSV instruction, located at a Flash memory address ending in 0x0, 0x4, 0x8 or 0xC; and c) The connecting code is at least two instruction words in length; and d) The connecting code does not end with a <code>REPEAT</code> instruction, with <code>count > 0</code>; and
3.	≥ 2 back-to-back PSV or <code>TBLRDx</code> instructions are executed (following the code of condition 2), where the first of the back-to-back instructions is located at an address ending in 0x2, 0x6, 0xA or 0xE.

Figure 9 provides an example of the effective behavior.

FIGURE 9: SIMPLIFIED BEHAVIOR

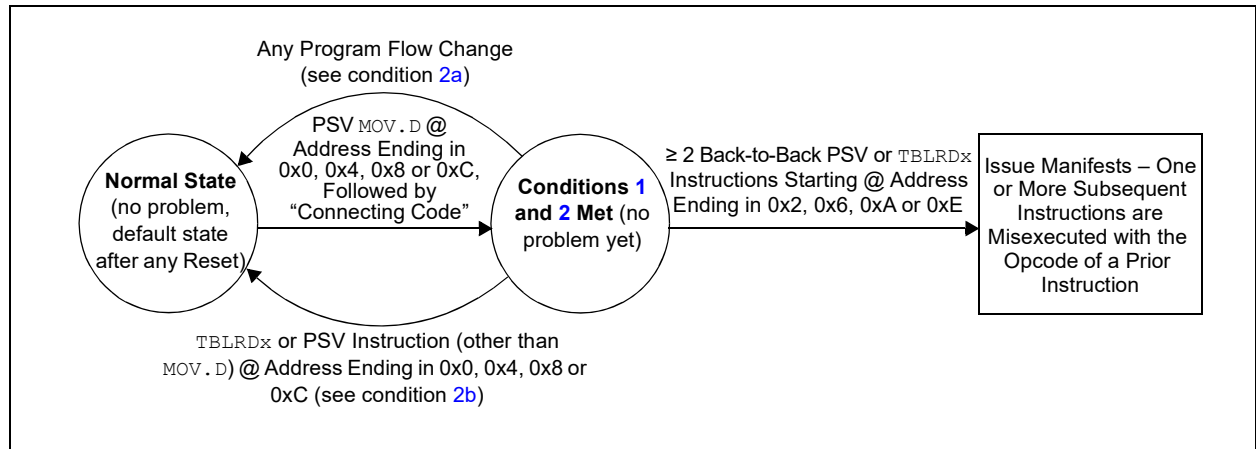

Work around

The issue can be avoided by ensuring any one or more of the requirements are not met. For example:

1. All instances of PSV `MOV.D` can be replaced with two PSV `MOV` instructions instead. Non-PSV `MOV.D` instructions acting on RAM/SFRs do not need to be modified; or
2. If not already present, a program flow change instruction (such as `BRA $+2`) can be inserted above back-to-back data Flash read sequences; or
3. Back-to-back data Flash read instruction sequences can be broken up by inserting a non-Flash read instruction (such as a `NOB`) in between the Flash read instructions; or
4. The alignment of the code can be shifted to avoid the required opcode location addresses.

C code built with MPLAB® XC16 Compiler, Version 1.32, or later, implements the work around by default. However, if the application uses Assembly language routines, these should be manually modified to implement the work around. Additionally, if precompiled libraries are used, these should be built with XC16 Version 1.32 or later. For additional information, please visit: www.microchip.com/erratum_psrds_psrds.

Affected Families and Silicon Revisions

Device	A2	A3	A7	A8	A9
dsPIC33/PIC24EP32		X		X	
dsPIC33/PIC24EP64	X	X		X	
dsPIC33/PIC24EP128		X		X	
dsPIC33/PIC24EP256		X		X	X
dsPIC33/PIC24EP512			X		

Data Sheet Clarifications

The following typographic corrections and clarifications are to be noted for the latest version of the device data sheet (DS70000657J):

<p>Note: Corrections are shown in bold. Where possible, the original bold text formatting has been removed for clarity.</p>

1. Module: Pin Diagrams

Removed VTLA packages from **Table 1** and **Table 2**. Removed all 36-pin and 44-pin VTLA pin diagrams because these package options are not available.

2. Module: Electrical Characteristics

Removed all VTLA packages from **Table 30-3: Thermal Packaging Characteristics** because these package options are not available.

3. Module: Packaging Information

Removed all 36-Lead and 44-Lead VTLA package marking information because these package options are not available.

4. Module: Product Identification System

Removed all VTLA packages because these package options are not available.

APPENDIX A: REVISION HISTORY

Rev A Document (11/2011)

Initial release of this document; issued for revision A2 silicon.

Includes silicon issues 1 (CPU), 2 (CPU) 3 (SPI), 4 (SPI), 5 (UART), 6 (Power System), 7 (ADC), 8 (PTG), 9 (Op Amp), 10 (Op Amp), 11 (PWM), 12 (Flash), 13 (QEI), 14 (QEI) and 15 (PWM).

Rev B Document (4/2012)

Updated silicon issues 9 (Op Amp), 10 (Op Amp), and 12 (Flash).

Added silicon issues 16 (ADC), 17 (ADC), 18 (Output Compare), and 19 (CAN).

Rev C Document (6/2012)

Updated document to include all related device families (program memory sizes of 32, 128, 256 and 512 Kbytes) in this superfamily. In the process, revised the document format to accommodate the different silicon revision levels across the different families.

Added silicon issues 20, 21 and 22 (PWM), and 23 (CPU) to all device families.

Added data sheet clarification 1 (Packaging).

Rev D Document (8/2012)

Updated Table 1 to include both A2 and A3 silicon revision device IDs and removed PIC24EP512/dsPIC32EP512 (A4). Updated all Affected Families and Silicon Revisions tables.

Added silicon issues 24 (PWM) and 25 (PWM).

Added data sheet clarification 2 (High-Speed PWM Module).

Rev E Document (3/2013)

Adds silicon revision A2 for all 64 Kbyte devices to all existing silicon issues, except 9 and 10 (Op Amp).

Revises issue 24 (PWM) with a figure to illustrate the timing of the issue.

Revises issue 25 (PWM) to clarify conditions, and add work around options.

Added new silicon issues 26 (PWM), 27 (CTMU), 28 (Input Capture), 29 (JTAG), 30 (I/O), 31 (JTAG) and 32 (QEI) to silicon revision A3 for all device families, and revision A2 for 64 Kbyte device families only.

Updates data sheet revision level to "G". Removes previous data sheet clarifications, which have been addressed in the new revision; adds new data sheet clarification 1 (Revision History).

Rev F Document (6/2013)

Updates document to include 512 Kbytes memory. Adds silicon issues 33 (QEI), 34 (QEI), 35 (PWM), 36 (PWM) and 37 (Op Amp/Comparator). Revises silicon issue 15 (PWM) description. Revises silicon issue 20 (PWM) with new figure and text. Revises issue 25 (PWM). Removes data sheet clarification 1 (Pin Diagrams) since this is now addressed in the current data sheet revision.

Rev G Document (9/2013)

Updates document to include revision A8 silicon.

Adds silicon issues 38-40 (PWM).

Modifies the Affected Families and Silicon Revisions table for issue 25 (PWM) with respect to the dsPIC33/PIC24EP512 devices. Updated Figure 1, relevant to issue 20 (PWM).

Rev H Document (02/2014)

Updates document to include silicon revision A8 for 128-Kbyte devices. All references to "ECAN" in this document are now changed to "CAN".

Added silicon issue 41 (CAN).

Updated Table 2, relevant to issue 41 (CAN). Modifies the Affected Families and Silicon Revisions table for issue 26 (PWM) and issue 36 (PWM).

Rev J Document (3/2014)

Updates document to include silicon revision A8 for 32-Kbyte devices.

Adds data sheet clarifications 1 (Electrical Characteristics), 2 (DC and AC Device Characteristics Graphs), 3 (Electrical Characteristics), 4 (Electrical Characteristics), 5 (Electrical Characteristics) and 6 (High-Temperature Electrical Characteristics).

Rev K Document (7/2014)

Updates document to add silicon revision A8 to all 256 Kbyte devices. Adds all existing silicon issues affecting silicon revision A8 for 64 Kbyte devices to revision A8 for 256 Kbyte devices.

Adds new silicon issues 42, 43 and 44 (PWM).

Amends silicon issue 4 (SPI) by correcting the state of the SPIFSD bit to '0'. (The text of the issue is otherwise unaffected and the issue is unchanged.)

Amends silicon issue 8 (PTG) by correcting the base prefix of the affected commands to '0b' instead of '0h'. (The text of the issue is otherwise unaffected and the issue is unchanged.)

Amends Table 5 in the work around for silicon issue 36 (PWM) by deleting the row corresponding to PCLKDIV[2:0] = 111, since this is a reserved setting. The basic issue is unchanged.

Amends silicon issue 38 (PWM) by adding additional text to the first paragraph to clarify the nature of the observed glitch. The basic issue is unchanged.

Adds data sheet clarifications 7 (I/O Ports), 8 (10/12-Bit Analog-to-Digital Converter (ADC)) and 9-10 (Comparator/Op Amp).

Rev L Document (12/2014)

Adds silicon revision A9 to dsPIC33EP256MC506. Adds silicon issues 45 (PWM) and 46 (PWM). Adds data sheet clarification 11 (Electrical Characteristics), 12 (High-Temperature Electrical Characteristics) and 13 (Power-Saving Features).

Rev M Document (8/2017)

Updates silicon issue 2 (CPU).

Adds silicon issue 47 (CPU).

Rev N Document (5/2018)

Adds 36-pin UQFN package related data sheet clarifications: 14 ([Introduction](#)), 15 ([Introduction](#)), 16 ([Packaging Information](#)), 17 ([Packaging Information](#)), 18 ([Electrical Characteristics](#)) and 19 ([Product Identification System](#)).

Rev P Document (8/2019)

Adds data sheet clarification 20 ([High-Temperature Electrical Characteristics](#)).

Rev Q Document (10/2019)

Updated silicon issue 12 ([Flash](#)).

Rev R Document (6/2020)

Updated all Affected Families and Silicon Revision tables to a new format.

Removed silicon issue 29 ([JTAG](#)) since it no longer applies.

Removed all data sheet clarifications because the issues were corrected in the latest data sheet revision.

Rev S Document (10/2020)

Added data sheet clarifications 1 ([Pin Diagrams](#)), 2 ([Electrical Characteristics](#)), 3 ([Packaging Information](#)) and 4 ([Product Identification System](#)).

NOTES:

Note the following details of the code protection feature on Microchip devices:

- Microchip products meet the specifications contained in their particular Microchip Data Sheet.
- Microchip believes that its family of products is secure when used in the intended manner and under normal conditions.
- There are dishonest and possibly illegal methods being used in attempts to breach the code protection features of the Microchip devices. We believe that these methods require using the Microchip products in a manner outside the operating specifications contained in Microchip's Data Sheets. Attempts to breach these code protection features, most likely, cannot be accomplished without violating Microchip's intellectual property rights.
- Microchip is willing to work with any customer who is concerned about the integrity of its code.
- Neither Microchip nor any other semiconductor manufacturer can guarantee the security of its code. Code protection does not mean that we are guaranteeing the product is "unbreakable." Code protection is constantly evolving. We at Microchip are committed to continuously improving the code protection features of our products. Attempts to break Microchip's code protection feature may be a violation of the Digital Millennium Copyright Act. If such acts allow unauthorized access to your software or other copyrighted work, you may have a right to sue for relief under that Act.

Information contained in this publication is provided for the sole purpose of designing with and using Microchip products. Information regarding device applications and the like is provided only for your convenience and may be superseded by updates. It is your responsibility to ensure that your application meets with your specifications.

THIS INFORMATION IS PROVIDED BY MICROCHIP "AS IS". MICROCHIP MAKES NO REPRESENTATIONS OR WARRANTIES OF ANY KIND WHETHER EXPRESS OR IMPLIED, WRITTEN OR ORAL, STATUTORY OR OTHERWISE, RELATED TO THE INFORMATION INCLUDING BUT NOT LIMITED TO ANY IMPLIED WARRANTIES OF NON-INFRINGEMENT, MERCHANTABILITY, AND FITNESS FOR A PARTICULAR PURPOSE OR WARRANTIES RELATED TO ITS CONDITION, QUALITY, OR PERFORMANCE.

IN NO EVENT WILL MICROCHIP BE LIABLE FOR ANY INDIRECT, SPECIAL, PUNITIVE, INCIDENTAL OR CONSEQUENTIAL LOSS, DAMAGE, COST OR EXPENSE OF ANY KIND WHATSOEVER RELATED TO THE INFORMATION OR ITS USE, HOWEVER CAUSED, EVEN IF MICROCHIP HAS BEEN ADVISED OF THE POSSIBILITY OR THE DAMAGES ARE FORESEEABLE. TO THE FULLEST EXTENT ALLOWED BY LAW, MICROCHIP'S TOTAL LIABILITY ON ALL CLAIMS IN ANY WAY RELATED TO THE INFORMATION OR ITS USE WILL NOT EXCEED THE AMOUNT OF FEES, IF ANY, THAT YOU HAVE PAID DIRECTLY TO MICROCHIP FOR THE INFORMATION. Use of Microchip devices in life support and/or safety applications is entirely at the buyer's risk, and the buyer agrees to defend, indemnify and hold harmless Microchip from any and all damages, claims, suits, or expenses resulting from such use. No licenses are conveyed, implicitly or otherwise, under any Microchip intellectual property rights unless otherwise stated.

For information regarding Microchip's Quality Management Systems, please visit www.microchip.com/quality.

Trademarks

The Microchip name and logo, the Microchip logo, Adaptec, AnyRate, AVR, AVR logo, AVR Freaks, BesTime, BitCloud, chipKIT, chipKIT logo, CryptoMemory, CryptoRF, dsPIC, FlashFlex, flexPWR, HELDO, IGLoo, JukeBlox, KeeLoq, Klear, LANCheck, LinkMD, maXStylus, maXTouch, MediaLB, megaAVR, Microsemi, Microsemi logo, MOST, MOST logo, MPLAB, OptoLyzer, PackeTime, PIC, picoPower, PICSTART, PIC32 logo, PolarFire, Prochip Designer, QTouch, SAM-BA, SenGenuity, SpyNIC, SST, SST Logo, SuperFlash, Symmetricom, SyncServer, Tachyon, TempTracker, TimeSource, tinyAVR, UNI/O, Vectron, and XMEGA are registered trademarks of Microchip Technology Incorporated in the U.S.A. and other countries.

APT, ClockWorks, The Embedded Control Solutions Company, EtherSynch, FlashTec, Hyper Speed Control, HyperLight Load, IntelliMOS, Libero, motorBench, mTouch, Powermite 3, Precision Edge, ProASIC, ProASIC Plus, ProASIC Plus logo, Quiet-Wire, SmartFusion, SyncWorld, Temux, TimeCesium, TimeHub, TimePictra, TimeProvider, Vite, WinPath, and ZL are registered trademarks of Microchip Technology Incorporated in the U.S.A.

Adjacent Key Suppression, AKS, Analog-for-the-Digital Age, Any Capacitor, AnyIn, AnyOut, BlueSky, BodyCom, CodeGuard, CryptoAuthentication, CryptoAutomotive, CryptoCompanion, CryptoController, dsPICDEM, dsPICDEM.net, Dynamic Average Matching, DAM, ECAN, EtherGREEN, In-Circuit Serial Programming, ICSP, INICnet, Inter-Chip Connectivity, JitterBlocker, KlearNet, KlearNet logo, memBrain, Mindi, MiWi, MPASM, MPF, MPLAB Certified logo, MPLIB, MPLINK, MultiTRAK, NetDetach, Omniscient Code Generation, PICDEM, PICDEM.net, PICkit, PICtail, PowerSmart, PureSilicon, QMatrix, REAL ICE, Ripple Blocker, SAM-ICE, Serial Quad I/O, SMART-I.S., SQR, SuperSwitcher, SuperSwitcher II, Total Endurance, TSHARC, USBCheck, VariSense, ViewSpan, WiperLock, Wireless DNA, and ZENA are trademarks of Microchip Technology Incorporated in the U.S.A. and other countries.

SQTP is a service mark of Microchip Technology Incorporated in the U.S.A.

The Adaptec logo, Frequency on Demand, Silicon Storage Technology, and Symmcom are registered trademarks of Microchip Technology Inc. in other countries.

GestIC is a registered trademark of Microchip Technology Germany II GmbH & Co. KG, a subsidiary of Microchip Technology Inc., in other countries.

All other trademarks mentioned herein are property of their respective companies.

© 2011-2020, Microchip Technology Incorporated, All Rights Reserved.

ISBN: 978-1-5224-6910-0



MICROCHIP

Worldwide Sales and Service

AMERICAS

Corporate Office
2355 West Chandler Blvd.
Chandler, AZ 85224-6199
Tel: 480-792-7200
Fax: 480-792-7277
Technical Support:
<http://www.microchip.com/support>
Web Address:
www.microchip.com

Atlanta

Duluth, GA
Tel: 678-957-9614
Fax: 678-957-1455

Austin, TX

Tel: 512-257-3370

Boston

Westborough, MA
Tel: 774-760-0087
Fax: 774-760-0088

Chicago

Itasca, IL
Tel: 630-285-0071
Fax: 630-285-0075

Dallas

Addison, TX
Tel: 972-818-7423
Fax: 972-818-2924

Detroit

Novi, MI
Tel: 248-848-4000

Houston, TX

Tel: 281-894-5983

Indianapolis

Noblesville, IN
Tel: 317-773-8323
Fax: 317-773-5453
Tel: 317-536-2380

Los Angeles

Mission Viejo, CA
Tel: 949-462-9523
Fax: 949-462-9608
Tel: 951-273-7800

Raleigh, NC

Tel: 919-844-7510

New York, NY

Tel: 631-435-6000

San Jose, CA

Tel: 408-735-9110
Tel: 408-436-4270

Canada - Toronto

Tel: 905-695-1980
Fax: 905-695-2078

ASIA/PACIFIC

Australia - Sydney
Tel: 61-2-9868-6733

China - Beijing
Tel: 86-10-8569-7000

China - Chengdu
Tel: 86-28-8665-5511

China - Chongqing
Tel: 86-23-8980-9588

China - Dongguan
Tel: 86-769-8702-9880

China - Guangzhou
Tel: 86-20-8755-8029

China - Hangzhou
Tel: 86-571-8792-8115

China - Hong Kong SAR
Tel: 852-2943-5100

China - Nanjing
Tel: 86-25-8473-2460

China - Qingdao
Tel: 86-532-8502-7355

China - Shanghai
Tel: 86-21-3326-8000

China - Shenyang
Tel: 86-24-2334-2829

China - Shenzhen
Tel: 86-755-8864-2200

China - Suzhou
Tel: 86-186-6233-1526

China - Wuhan
Tel: 86-27-5980-5300

China - Xian
Tel: 86-29-8833-7252

China - Xiamen
Tel: 86-592-2388138

China - Zhuhai
Tel: 86-756-3210040

ASIA/PACIFIC

India - Bangalore
Tel: 91-80-3090-4444

India - New Delhi
Tel: 91-11-4160-8631

India - Pune
Tel: 91-20-4121-0141

Japan - Osaka
Tel: 81-6-6152-7160

Japan - Tokyo
Tel: 81-3-6880-3770

Korea - Daegu
Tel: 82-53-744-4301

Korea - Seoul
Tel: 82-2-554-7200

Malaysia - Kuala Lumpur
Tel: 60-3-7651-7906

Malaysia - Penang
Tel: 60-4-227-8870

Philippines - Manila
Tel: 63-2-634-9065

Singapore
Tel: 65-6334-8870

Taiwan - Hsin Chu
Tel: 886-3-577-8366

Taiwan - Kaohsiung
Tel: 886-7-213-7830

Taiwan - Taipei
Tel: 886-2-2508-8600

Thailand - Bangkok
Tel: 66-2-694-1351

Vietnam - Ho Chi Minh
Tel: 84-28-5448-2100

EUROPE

Austria - Wels
Tel: 43-7242-2244-39
Fax: 43-7242-2244-393

Denmark - Copenhagen
Tel: 45-4485-5910
Fax: 45-4485-2829

Finland - Espoo
Tel: 358-9-4520-820

France - Paris
Tel: 33-1-69-53-63-20
Fax: 33-1-69-30-90-79

Germany - Garching
Tel: 49-8931-9700

Germany - Haan
Tel: 49-2129-3766400

Germany - Heilbronn
Tel: 49-7131-72400

Germany - Karlsruhe
Tel: 49-721-625370

Germany - Munich
Tel: 49-89-627-144-0
Fax: 49-89-627-144-44

Germany - Rosenheim
Tel: 49-8031-354-560

Israel - Ra'anana
Tel: 972-9-744-7705

Italy - Milan
Tel: 39-0331-742611
Fax: 39-0331-466781

Italy - Padova
Tel: 39-049-7625286

Netherlands - Drunen
Tel: 31-416-690399
Fax: 31-416-690340

Norway - Trondheim
Tel: 47-7288-4388

Poland - Warsaw
Tel: 48-22-3325737

Romania - Bucharest
Tel: 40-21-407-87-50

Spain - Madrid
Tel: 34-91-708-08-90
Fax: 34-91-708-08-91

Sweden - Gothenberg
Tel: 46-31-704-60-40

Sweden - Stockholm
Tel: 46-8-5090-4654

UK - Wokingham
Tel: 44-118-921-5800
Fax: 44-118-921-5820