

This kit includes a wind vane ,cup anemometer, and tipping bucket rain gauge, with associated mounting hardware .These sensors contain no active electronics, instead using sealed magnetic reed switches and magnets to take measurements. A voltage must be supplied to each instrument to produce an output.

Assembly

The wind sensor arm mounts on top of the two-piece metal and supports the wind vane and anemometer. A short cable connects the two win sensors. Plastic clips on the underside of the arm hold this cable in place. Screws are provided to secure the sensors to the arm. The rain gauge may be mounted lower on the mast using its own mounting arm and screw, or it may be mounted independently.

Rain Gauge

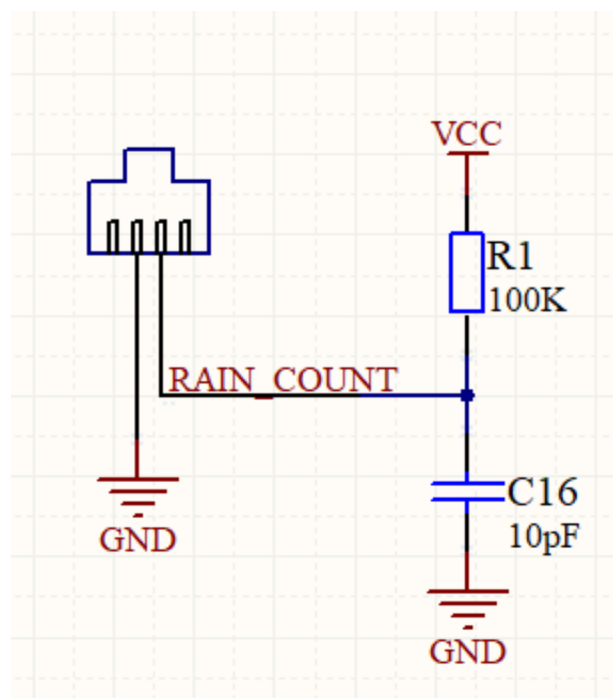

The rain gauge is a self-emptying tipping bucket type. Each 0.2794mm of rain cause one momentary contact closure that can be recorded with a digital counter or microcontroller interrupt input. The gauge's switch is connected to the two center conductors of the attached RJ 11-terminated cable.

Anemometer

The cup-type anemometer measures wind speed by closing a contact as a magnet moves past a switch. A wind speed of 2.4km/h causes the switch to close once per second.

The anemometer switch is connected to the inner two conductors of the RJ 11 cable shared by the anemometer and wind vane(pins 2 and 3)

Wind Vane

Direction (degrees)	Resistance (ohms)
0	33K
22.5	6.57K
45	8.2K
67.5	891
90	1K
112.5	688
135	2.2K
157.5	1.41K
180	3.9K
202.5	3.14K
225	16K
247.5	14.12K
270	120K
292.5	42.12K
315	64.9K
337.5	21.88K

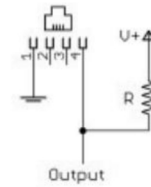
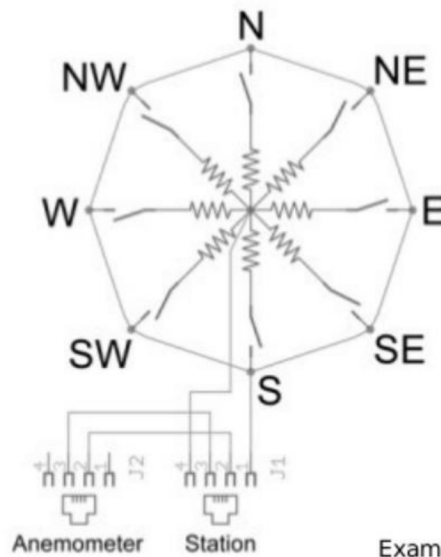

Example wind vane interface circuit. Voltage readings for a 5 volt supply and a resistor value of 10k ohms are given in the table.

The wind vane is the most complicated of the three sensors. It has eight switches, each connected to a different resistor. The vane's magnet may close two switches at once, allowing up to 16 different positions to be indicated. An external resistor can be used to form a voltage divider, producing a voltage output that can be measured with an analog to digital converter, as shown below.

The switch and resistor arrangement is shown in the diagram to the right. Resistance values for all 16 possible positions are given in the table.

Resistance values for positions between those shown in the diagram are the result of two adjacent resistors connected in parallel when the vane's magnet activates two switches simultaneously.