

Part Number: 1930X23X

Type	Size	Rating	Description
LED	M14	230VAC	Standard Bezel Panel Indicator

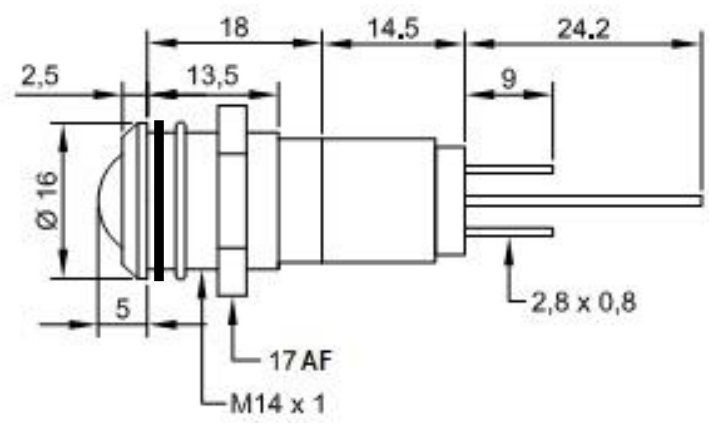

Part #	Colour	Voltage(V)	Current(mA)	Intensity(mcd)
1930X230	Red	230Vac	3	18
1930X231	Green	230Vac	3	11
1930X233	Yellow	230Vac	3	8

Notes:

- 1 X = Chrome Bezel finish. 0 = Satin, 1 = Black, 2 = Matt
- 2 Electrical & optical data are measured at an ambient temperature of 25°C
- 3 Luminous intensity at AC
- 4 Storage temperature -25 °C to +80°C
- 5 Application temperature -20 °C to +60°C
- 6 Voltage tolerance ±10%
- 7 Due to component tolerances, colour temperature variations may be observed
- 8 The terminals are not qualified for soldering
- 9 Degree of protection IP67 when used with the supplied gasket
- 10 The plastic(polycarbonate) has limited chemical resistance
- 11 RoHS & REACH SVHC compliant