

Part Number: 327

Type	Size	Rating	Description
Incandescent	T6	28V 40mA	T-1¾ Midget Flange Lamp

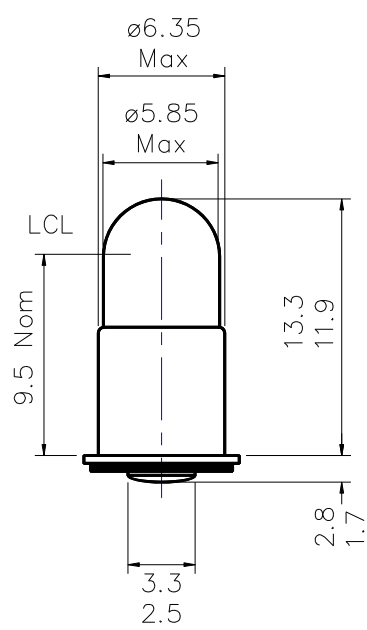

Dimensions in millimetres

TEST VOLTS	CURRENT (mA)			LIGHT OUTPUT (Lm)			LIFE Hours
	Min.	Nom.	Max.	Min.	Nom.	Max.	
28	36	40	44	3.2	4.3	5.4	4,000

Notes:

- 1 **Base Type** Nickel plated SX6s base to BS EN 60061-1
- 2 **Filament Shape** C-2F
- 3 **Bead Colour** White or clear
- 4 **Lamp Marking** CML 327 28V 40mA
- 5 **Environmental** RoHS & REACH SVHC compliant