

PRODUCT DATA SHEET

Part Number: 8-2402

Type	Size	Rating	Description
Incandescent	T3	28V 24mA	T-1 Bi-pin Lamp

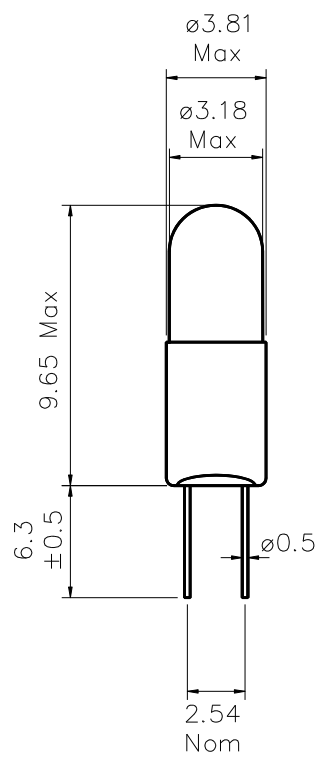

Dimensions in millimetres

TEST VOLTS	CURRENT (mA)			LIGHT OUTPUT (Lm)			LIFE Hours
	Min.	Nom.	Max.	Min.	Nom.	Max.	
28	21.5	24.0	26.4	1.4	1.9	2.4	4,000

Notes:

- 1 **Base Type** White Nylon Bi-pin, 2.54mm pin spacing
- 2 **Filament Shape** CC-2F
- 3 **Lamp Marking** 28V
- 4 **Environmental** RoHS & REACH SVHC compliant