

Part Number: W1121T

Type	Size	Rating	Description
Incandescent	T10	130V 20mA	T-3¼ Miniature Bayonet Lamp

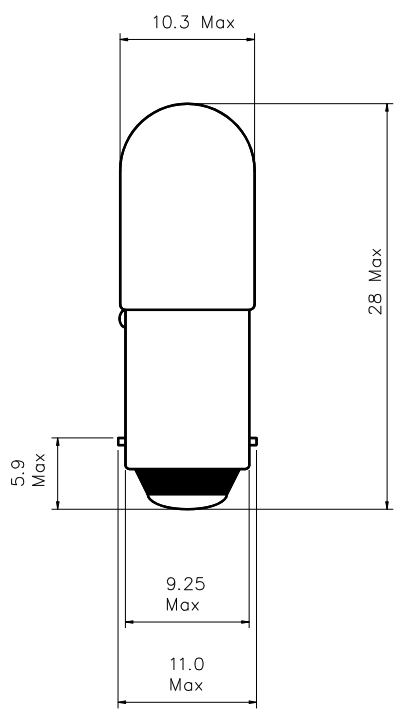

Dimensions in millimetres

TEST VOLTS	CURRENT (mA)			LIGHT OUTPUT (Lm)			LIFE Hours
	Min.	Nom.	Max.	Min.	Nom.	Max.	
130	18	20	22	2.8	3.8	4.8	5,000

Notes:

- 1 **Base Type** BA9s/13 in accordance with BS EN60061-1
- 2 **Filament Shape** 2 x CC-2F
Filament in line with pins $\pm 30^\circ$
LCL 16 \pm 1mm
- 3 **Lamp Marking** VCH 130V 20mA
- 4 **Bead Colour** White or clear
- 5 **Conformity** RoHS & REACH SVHC compliant
73/23/EEC and 93/68/EEC
CE marking