

Part Number:

13212000

Type	Size	Rating	Description
Incandescent	B-3½	12V 0.25A	Pre-Focus (torch)

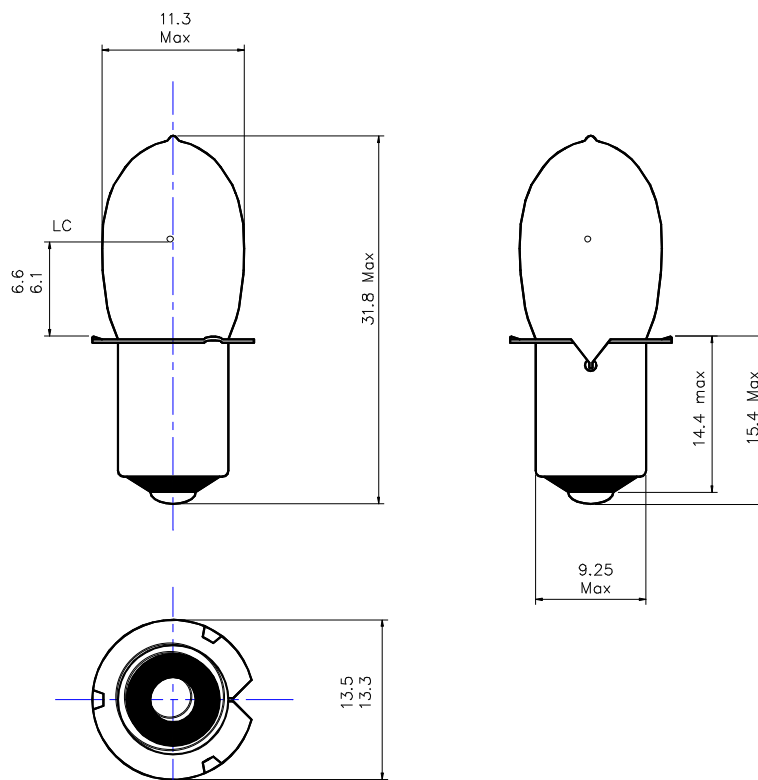

Dimensions in millimetres

TEST VOLTS	CURRENT (mA)			LIGHT OUTPUT (Lm)			LIFE Hours
	Min.	Nom.	Max.	Min.	Nom.	Max.	
12	225	250	275	25	34	42	-

Notes:

- 1 **Base Type** P13.5s Nickel plated pre-focus
- 2 **Filament Shape** C-2R
- 3 **Lamp Marking** 12V 0.25A or 12.5V 0.25A
- 4 **Environmental** RoHS & REACH SVHC compliant