

NEW 2D CRIMP AMPLIVAR SPLICE

PRODUCT DESCRIPTION

Our innovative new 2D AMPLIVAR splices combine the superior connection and easy to use features of AMPLIVAR splices with our innovative 2D crimp technology to provide a magnet wire splice solution that is easy to use and that can simplify inventory and manufacturing processes at the same time.

New 2D AMPLIVAR splices are offered in pigtail and thru types that can be used with stranded or solid copper or aluminum magnet wire (3 magnet wires max.) of various sizes and combinations. The innovation behind TE's 2D crimp technology is its ability to use one splice and a single adjustable applicator across many different wire sizes. That means only 1 splice part number is required to be used across a broad range (600-7000 CMA) of wire sizes. The reduction of part and applicators needed significantly reduces the complexity of design-in, assembly, procurement and inventory management.

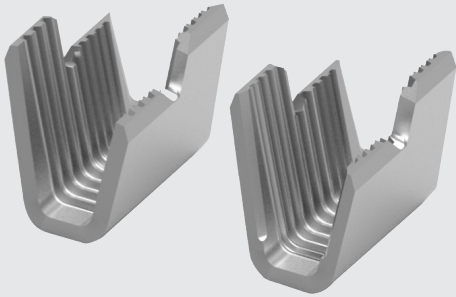

INDUSTRIES

MOTORS, FANS, VALVES AND PUMPS FOUND WITHIN:

- Small Home Appliances
- Major Home Appliances
- HVAC
- Automotive
- Industrial Machinery and Automation

TECHNICAL DETAILS

- Material: Tin Plated Brass
- Product Specification: 108-143147
- Application Specification: 114-143147
- Temperature Rating: -65°C to 150°C

KEY FEATURE AND BENEFITS

- Can be used with copper or aluminum magnet wires (3 magnet wires max.)
- Eliminates soldering or welding processes providing applied cost savings through improving operating efficiency
- Eliminating the soldering or welding processes reduces the risks of potentially damaging heat-sensitive wiring and/or emitting chemical fumes
- Pre-stripping of wires is not needed - saving time and reducing waste
- 2D technology allows for automation of the magnet wire termination process which offers a reliable and stable manufacturing process with consistent quality results

PART DETAILS

Part Number	Description	AWG Range	CMA Range	Stock Thickness
2238235-1 (pkg on reel)	AMPLIVAR 2D Splice, Thru	22-12 AWG	600-7000	0.020" (0.51mm)
2238236-1 (pkg on reel)	AMPLIVAR 2D Splice, Open Barrel Pigtail	22-12 AWG	600-7000	0.020" (0.51mm)

*Arbor press manual unit and appropriate tooling pack required

NEW 2D CRIMP AMPLIVAR SPLICE

TOOLING

For Low Volume Production:

- Arbor Press Assembly 2380993-1 (Manual Power Unit)
- Tooling Pack (pig-tail splice) 2380996-1
- Tooling Pack (thru splice) 2380997-1

For High Volume Production:

- APT 5A AMPLIVAR machine (for pigtail splice) 1-2161800-9
- Model GII press 2217000-1 or AMP 5K/40 2161500-1 (both for pigtail splice) + the respective Ocean Applicator
- Model GII thru-splice 2217002-1 or AMP 5K/40 thru-splice 2161300-1 (both for thru-splice) + the respective Thru-Splice Applicator

* Instruction sheet for Manual Arbor Press with Removable Tooling Packs: 408-160034



Thru Splice



Pigtail Splice

2D AMPLIVAR PIG-TAIL AND THRU SPLICE TERMINATION PROCESS

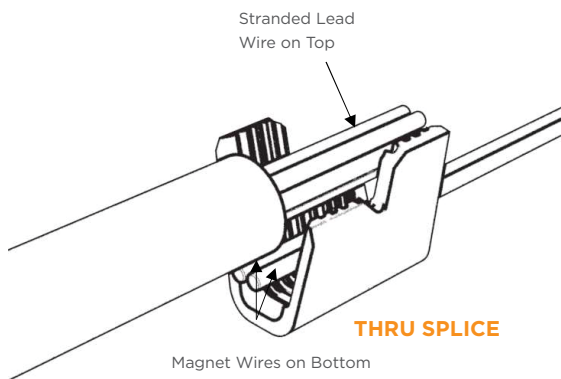
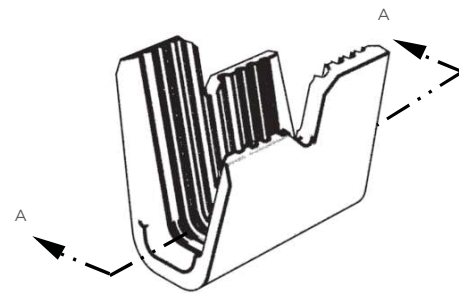
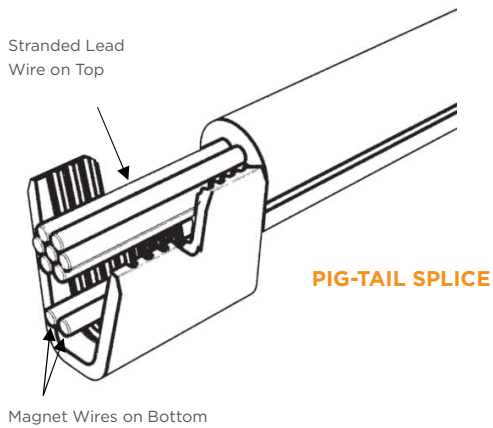

SECTION A-A

NEW 2D CRIMP AMPLIVAR SPLICE

2D AMPLIVAR SPLICE TERMINATION INSPECTION

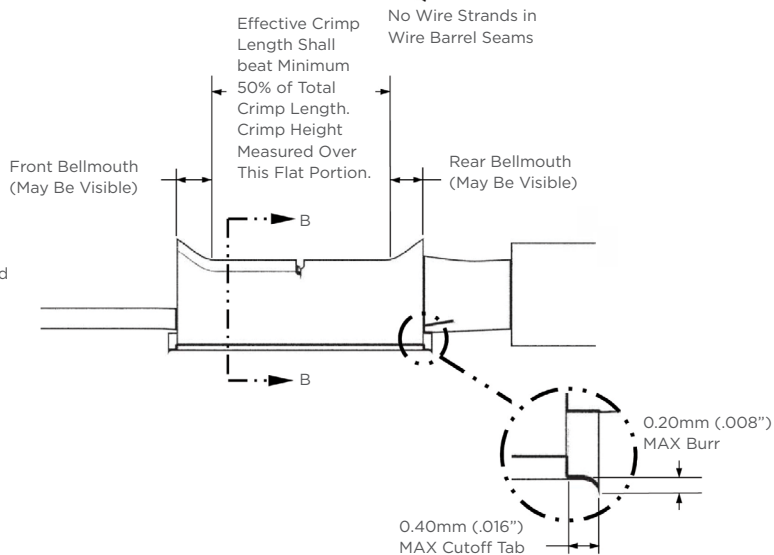
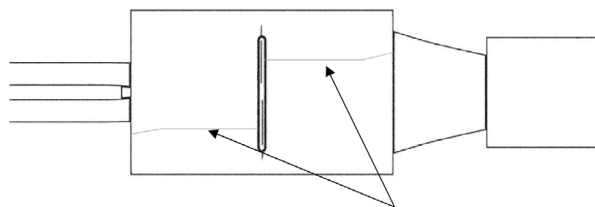
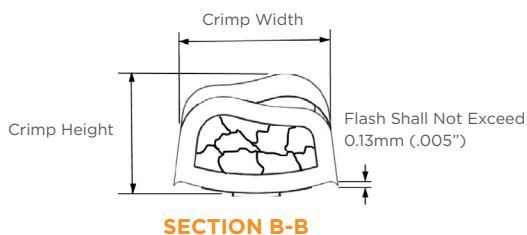
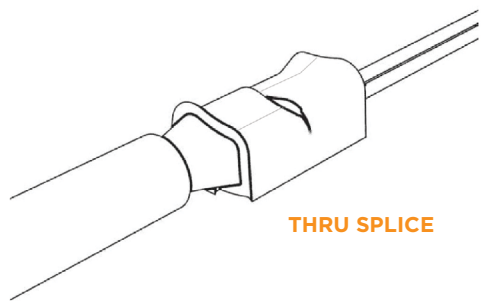

TE TECHNICAL SUPPORT CENTER

USA:	+1 (800) 522-6752
Canada:	+1 (905) 475-6222
Mexico:	+52 (0) 55-1106-0800
Latin/S. America:	+54 (0) 11-4733-2200
Germany:	+49 (0) 6251-133-1999
UK:	+44 (0) 800-267666
France:	+33 (0) 1-3420-8686
Netherlands:	+31 (0) 73-6246-999
China:	+86 (0) 400-820-6015

te.com

AMPLIVAR, TE, TE Connectivity and TE connectivity (logo) are trademarks owned or licensed by the TE Connectivity Ltd. family of companies. All other logos, products and/or company names referred to herein might be trademarks of their respective owners.

The information given herein, including drawings, illustrations and schematics which are intended for illustration purposes only, is believed to be reliable. However, TE Connectivity makes no warranties as to its accuracy or completeness and disclaims any liability in connection with its use. TE Connectivity's obligations shall only be as set forth in TE Connectivity's Standard Terms and Conditions of Sale for this product and in no case will TE Connectivity be liable for any incidental, indirect or consequential damages arising out of the sale, resale, use or misuse of the product. Users of TE Connectivity products should make their own evaluation to determine the suitability of each such product for the specific application.

© 2021 TE Connectivity Ltd. family of companies All Rights Reserved.

9-1773984-6 02/21 Original