

# DATA SHEET

## GAS DISCHARGE TUBES TELEPHONE INTERFACE

3R-8 series

RoHS compliant & free



Product specification—April 26, 2021 V.1



## Gas Discharge Tube (GDT) Data Sheet

### Features

- Provide ultra-fast response to surge voltage from slow-rising surge of 100V/s to rapid-rising surge of 1KV/μs
- Stable breakdown voltage
- High insulation resistance
- Low capacitance (≤2pF)
- High holdover voltage
- Large absorbing transient current capability
- Micro-Gap Design
- Size: 8.0mm\*10.0mm
- Storage and operating temperature: -40°C ~ +85°C
- Meets MSL level 1, per J-STD-020
- Safety certification: UL



### Applications

- Repeaters, Modems
- Telephone Interface, Line cards
- Data communication equipment
- Line test equipment

### Part Number Code

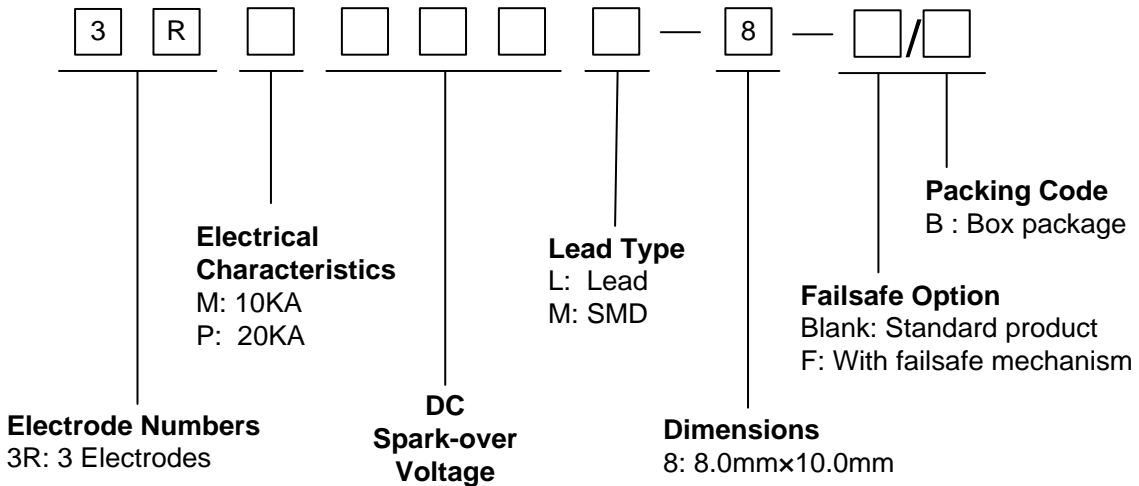

Ordering Code	Lead type	Failsafe option	Package
3RMXXXL-8/B 3RPXXXL-8/B	Lead		Box(Tray)
3RMXXXL-8-F/B 3RPXXXL-8-F/B	Lead	With failsafe mechanism	Box(Tray)
3RMXXXM-8 3RPXXXM-8	SMD		Tape & Reel

**Marking**

**B** : BrightKing Logo

3RM090-8 : Device Marking Code

XXXX : Internal Control Code

**Dimensions**

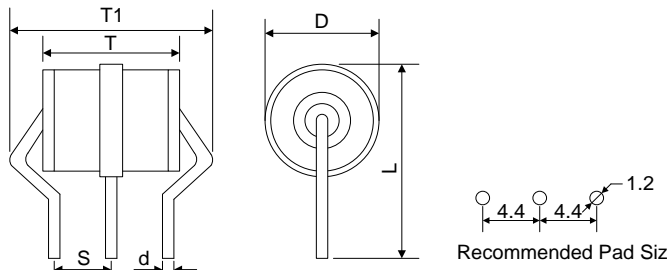
L Type	Symbol	Dimension (mm)	
		Spec.	Tolerance
	D	8.0	+0.2, -0.8
	T	10.0	±0.5
	T1	12.0	±0.5
	L	15.0	±0.5
L-F Type	S	4.4	±0.4
	d	1.0	±0.1
	R1	9.8	±0.4
	R2	8.1	±0.3
M Type	D	8.0	+0.2, -0.8
	T	10.0	±0.5
	B	0.5	±0.1
	B1	1.5	±0.2

Notes: This type is not suitable for PCB soldering.

**Electrical Characteristics (3RM-8)**

Part Number	DC Spark-over Voltage	Maximum Impulse Spark-over Voltage	Nominal Impulse Discharge Current	Alternating Discharge Current	Impulse Life	Minimum Insulation Resistance		Maximum Capacitance		Device Marking Code
						Test Voltage	(GΩ)	1MHz		
						(V)		(pF)		
3RM075L-8	3RM075M-8	75±20%	700	10	10	300	25	1.0	2.0	3RM075-8
3RM090L-8	3RM090M-8	90±20%	700	10	10	300	50	1.0	2.0	3RM090-8
3RM150L-8	3RM150M-8	150±20%	700	10	10	300	100	1.0	2.0	3RM150-8
3RM200L-8	3RM200M-8	200±20%	700	10	10	300	100	1.0	2.0	3RM200-8
3RM230L-8	3RM230M-8	230±20%	700	10	10	300	100	1.0	2.0	3RM230-8
3RM350L-8	3RM350M-8	350±20%	850	10	10	300	100	1.0	2.0	3RM350-8
3RM400L-8	3RM400M-8	400±20%	850	10	10	300	100	1.0	2.0	3RM400-8
3RM470L-8	3RM470M-8	470±20%	950	10	10	300	250	1.0	2.0	3RM470-8
3RM600L-8	3RM600M-8	600±20%	1300	10	10	300	250	1.0	2.0	3RM600-8

**Electrical Characteristics (3RP-8)**

Part Number		DC Spark-over Voltage	Maximum Impulse Spark-over Voltage	Nominal Impulse Discharge Current	Alternating Discharge Current	Impulse Life	Minimum Insulation Resistance		Maximum Capacitance	Device Marking Code
		100V/s	1000V/ $\mu$ s	8/20 $\mu$ s 10times	50Hz,1sec	10/1000 $\mu$ s 100A	Test Voltage	(G $\Omega$ )	1MHz	
		(V)	(V)	(KA)	(A)	(times)	DC(V)		(pF)	
3RP075L-8	3RP075M-8	75 $\pm$ 20%	700	20	20	300	25	1.0	2.0	3RP075-8
3RP090L-8	3RP090M-8	90 $\pm$ 20%	700	20	20	300	50	1.0	2.0	3RP090-8
3RP150L-8	3RP150M-8	150 $\pm$ 20%	700	20	20	300	100	1.0	2.0	3RP150-8
3RP200L-8	3RP200M-8	200 $\pm$ 20%	700	20	20	300	100	1.0	2.0	3RP200-8
3RP230L-8	3RP230M-8	230 $\pm$ 20%	700	20	20	300	100	1.0	2.0	3RP230-8
3RP350L-8	3RP350M-8	350 $\pm$ 20%	850	20	20	300	100	1.0	2.0	3RP350-8
3RP400L-8	3RP400M-8	400 $\pm$ 20%	850	20	20	300	100	1.0	2.0	3RP400-8
3RP470L-8	3RP470M-8	470 $\pm$ 20%	950	20	20	300	250	1.0	2.0	3RP470-8
3RP600L-8	3RP600M-8	600 $\pm$ 20%	1300	20	20	300	250	1.0	2.0	3RP600-8

**Electrical Ratings**

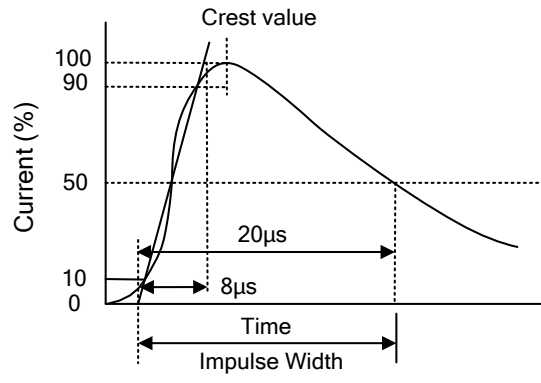
Items	Test Condition/Description	Requirement
DC Spark-over Voltage	The voltage is measured with voltage ramp $dv/dt=100V/s$ . Test is between each side electrode and center electrode.	
Maximum Impulse Spark-over Voltage	The maximum impulse spark-over voltage is measured with voltage ramp $dv/dt=1000V/\mu s$ . Test is between each side electrode and center electrode.	
Impulse Discharge Current	<p>Maximum surge current that can be applied through center electrode with 8/20<math>\mu s</math> waveform, for 10 times with 3min interval time, which will be equally divided between each side electrode to center electrode.</p> 	To meet the specified value
Alternating Discharge Current	Rated RMS value of AC current at 50Hz, 1 sec. for 10 times with interval time 3 min. Test is between each side electrode and center electrode.	
Insulation Resistance	The resistance of gas tube shall be measured between each side electrodes and center electrode.	
Capacitance	The capacitance of gas tube shall be measured between each side electrodes and center electrode. Test frequency: 1MHz	

**Recommended Soldering Conditions**

**Wave Soldering**

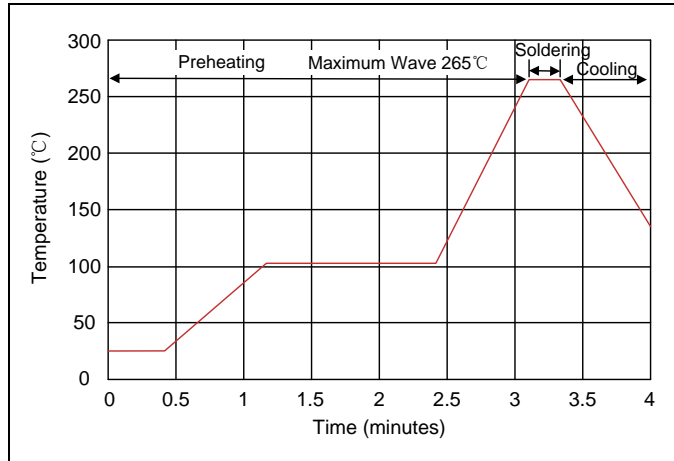

Item	Conditions
Peak Temperature	265°C
Dipping Time	10 seconds
Soldering	1 time

**Reflow Soldering**

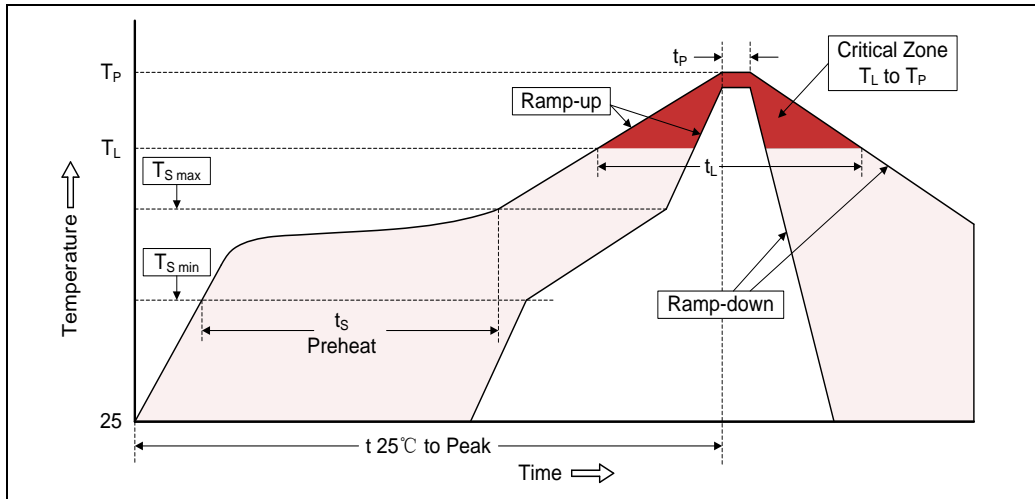

Profile Feature	Pb-Free Assembly
Average ramp-up rate (TL to TP)	3°C/second max.
Preheat -Temperature Min (TS min) -Temperature Max (TS max) -Time (min to max) (ts)	150°C 200°C 60-180 seconds
TS max to TL -Ramp-up Rate	3°C/second max.
Time maintained above: -Temperature (TL) -Time (tL)	217°C 60-150 seconds
Peak Temperature (TP)	260°C
Time within 5°C of actual Peak Temperature (tp)	20-40 seconds
Ramp-down Rate	6°C/second max.
Time 25°C to Peak Temperature	8 minutes max.

**Packaging**

Axial Packing (Box)

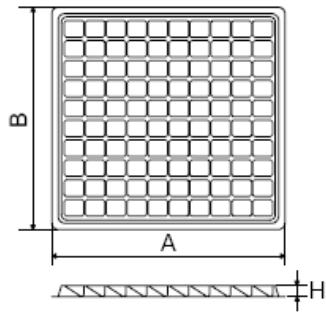
Skin packing	Symbol	Dimension (mm)	
		Spec.	Tolerance
	A	217.0	±2.0
	B	207.0	±2.0
	H	10.3	±0.5
	Quantity: 100pcs		
Inner box	A0	225.0	±2.0
	B0	210.0	±2.0
	H0	60.0	±2.0
	Quantity: 500pcs		

SMD Packing (Tape & Reel)

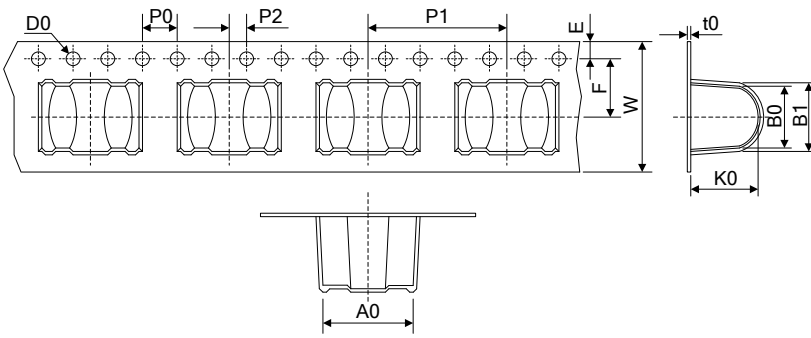
Tape	Symbol	Dimension (mm)		
		Spec.	Tolerance	
	W	16.00	±0.20	
	P0	4.00	±0.10	
	P1	16.00	±0.10	
	P2	2.00	±0.10	
	D0	1.55	±0.05	
	E	1.75	±0.10	
	F	7.50	±0.10	
	A0	11.60	±0.10	
	K0	8.90	±0.10	
	B0	8.60	±0.10	
	B1	10.00	±0.10	
	t0	0.50	±0.05	
	Reel	D	330.00	±2.00
		d	13.00	±0.50
		L	20.00	±2.00
t		2.00	±0.20	
Quantity: 300pcs				